



## EFIS Equipment - Database Compatibility Matrix

REVISION HISTORY FOLLOWS ON PAGE 2.

**WARNING:** A printed copy of this document may not be the latest revision. It is the responsibility of the user to ensure that the latest revision is used. The latest revision of this document may be printed from the Genesys Aerosystems, Inc. electronic document repository.

THIS DOCUMENT CONTAINS PROPRIETARY INFORMATION OF GENESYS AEROSYSTEMS, INC., A GENESYS AERSYSTEMS GROUP COMPANY, NEITHER RECEIPT, NOR POSSESSION THEREOF, CONFERS ANY RIGHT TO REPRODUCE OR USE, OR DISCLOSE, IN WHOLE OR IN PART, ANY SUCH INFORMATION WITHOUT WRITTEN AUTHORIZATION FROM GENESYS AEROSYSTEMS, INC.

<b>APPROVAL</b>	<b>NAME</b>	<b>PURPOSE:</b> This document identifies the EFIS equipment that utilizes navigation and obstacle databases, and specifies compatibility between equipment and database versions.	
AUTHOR	<b>Dirk ter Veer</b>		
CHECK	<b>Dean Boston</b>		
QUALITY	<b>Jo Gottumukkala</b>		
COGNIZANT	<b>Rick Price</b>		
COGNIZANT	<b>Stacie Burkhardt</b>		
COGNIZANT			
RELEASE DATE: 16 Apr 2018			
<b>STATUS</b>	Typed signatures indicate approval. Handw ritten, or electronic signature approval of this document is on file at Genesys Aerosystems, Inc., Anchorage, Alaska.	DOCUMENT NUMBER	REV
<b>Released</b>		<b>01-000062</b>	<b>F</b>

## REVISION RECORD

Rev	Notes	Date	Author
F	<ol style="list-style-type: none"> <li>1. Removed “Referenced Documents”, “List of Acronyms”, and “System Overview” sections.</li> <li>2. Removed software part numbers and consolidated hardware part numbers in “EFIS Software Revisions” section.</li> <li>3. Simplified “Database Compatibility by Software Revision” section by specifying 3 software revision ranges (7.0C and earlier, 7.0D-8.0C, 8.0D and later).</li> </ol>	See cover page	D. ter Veer
E	<p>LOA documents are being reviewed for minor clarification changes, stream lining processes to reduced nonessential documentation, and update references for withdrawn documents.</p> <ol style="list-style-type: none"> <li>1. On cover paged corrected name of quality personnel.</li> <li>2. In section 2.1.1 removed withdrawn documents and added the replacement/equivalent SOP.</li> </ol>	05/07/2017	D. LaRue
D	<ol style="list-style-type: none"> <li>1. Add §4.3 to describe obstruction database for part numbers in §5 that include the obstruction database. Add obstruction database documents to §2.1.1.</li> <li>2. Update §2.1.2 with new Pilot Guides..</li> <li>3. §5 Compatibility Matrix changes:               <ol style="list-style-type: none"> <li>a. Added §5.1 to define database part number.</li> <li>b. Split compatibility matrix into §5.2 and §5.3. §5.2 defines the EFIS software versions for all equipment and §5.3 defines the compatible navigation database part numbers for each EFIS software version.</li> <li>c. Added experimental equipment to §5.2 to assist customer support and Jeppesen.</li> </ol> </li> <li>4. Add Appendix 1 to assist in identifying EFIS equipment, hardware part numbers, and EFIS software revisions.</li> </ol>	05/18/2016	D. Boston
C	<ol style="list-style-type: none"> <li>1. Rebranding document update from Chelton Flight Systems to Genesys Aerosystems, Inc.</li> <li>2. §5 Compatibility Matrix Changes:               <ol style="list-style-type: none"> <li>a. IDU-IV IDU-450 42-024001-0001 / -00002: 8.0D (pending) ~ Current Pending Version</li> <li>b. IDU-IV IDU-680P 42-006001-0001: 8.0C (pending) ~ Current Pending Version</li> </ol> </li> </ol>	11/05/2014	M. Johnston
B	<ol style="list-style-type: none"> <li>1. Correct formatting for PDF version.</li> <li>2. Sec 1.2: Add reference to DQR document, 20-000076.</li> <li>3. Sec 2.1: Add 20-000076. Update reference documents.</li> <li>4. Sec 5: Update pending software versions.</li> </ol>	09/12/2013	D. Boston
A	Original Version	07/24/2013	D. Boston

## TABLE OF CONTENTS

<b>1</b>	<b>SCOPE.....</b>	<b>4</b>
1.1	DOCUMENT IDENTIFICATION AND OVERVIEW.....	4
1.2	RELATIONSHIP TO OTHER DOCUMENTS .....	4
<b>2</b>	<b>DATABASE COMPATIBILITY MATRIX.....</b>	<b>5</b>
2.1	DATABASE PART NUMBER.....	5
2.2	EFIS SOFTWARE REVISIONS.....	7
2.3	DATABASE COMPATIBILITY BY SOFTWARE REVISION.....	8
	<b>APPENDIX 1: EQUIPMENT IDENTIFICATION.....</b>	<b>9</b>

# **1 SCOPE**

## **1.1 DOCUMENT IDENTIFICATION AND OVERVIEW**

This document identifies the EFIS equipment that utilizes navigation and obstacle databases, and specifies compatibility between equipment and database versions. This document addresses FAA Advisory Circular (AC) 20-153A, Appendix A Objective 3-2.

## **1.2 RELATIONSHIP TO OTHER DOCUMENTS**

This document is part of the Type 2 Letter of Authorization (LOA) process definition to meet the requirements of RTCA/DO-200A and FAA AC 20-153A for navigation databases used in the Integrated Display Unit (IDU) Electronic Flight Instrument System (EFIS). The intended functions for the navigation database as utilized in the EFIS equipment are described in document 20-000076, *Navigation Database – Data Quality Requirements (DQRs)*.

This document is also part of the RTCA/DO-200A requirements for producing an aeronautical obstruction database as described in document 21-000005, *Obstruction Database Conversion – Software Requirements*. The obstruction database is not covered by the Type 2 LOA and is defined here because it may be bundled with the navigation database.

## 2 DATABASE COMPATIBILITY MATRIX

### 2.1 DATABASE PART NUMBER

The IDU navigation database can be delivered stand-alone or bundled with the obstruction database. The part number of the stand-alone or bundled database product is encoded as follows:

Database Part Number = **CS**[A][BBB]\_[xxxx]\_[wwwwwww]

[A]	Description	
	EFIS Software Revision	Database
1	7.0D to 8.0C	NavData only
2	7.0C and earlier	NavData only
3	7.0D to 8.0C	NavData bundled with Obstacles
4	7.0C and earlier	NavData bundled with Obstacles
5	8.0D and later	NavData only
6	8.0D and later	NavData bundled with Obstacles

[BBB] <sup>[1]</sup>	Coverage
001	World
002	Americas
003	International
CAP	Capstone tailored World
REG	Rega tailored World

Notes: [1] [BBB] can be any 3-letter identifier to accommodate future tailored databases.

Field	Description
[xxxx]	Database cycle number (for example: 1604) per Update and Effectivity Schedule published by Jeppesen ( <a href="http://www.jeppesen.com">www.jeppesen.com</a> ). 8-character CRC value changes with each cycle based on the contents of the database file.
[wwwwwww]	8-character hexadecimal 32-bit CRC of database file. For example: EE9DB378.

## Database Part Number Examples

Database Part Number	Decoding
CS4002_1604_EE9DB378	Part Number Prefix: CS4002 Contents: NavData bundled with Obstacles EFIS Software Revision: 7.0C and earlier Coverage: Americas Cycle: 1604 Filename: CS4002_1604_EE9DB378.zip
CS3REG_1513_7445F065	Part Number Prefix: CS3REG Contents: NavData bundled with Obstacles EFIS Software Revision: 7.0D to 8.0C Coverage: Rega tailored World Cycle: 1513 Filename: CS3REG_1513_7445F065.zip
CS5001_1608_2E5E0A8A	Part Number Prefix: CS5001 Contents: NavData only EFIS Software Revision: 8.0D and later Coverage: World Cycle: 1608 Filename: CS5001_1608_2E5E0A8A.zip

## 2.2 EFIS SOFTWARE REVISIONS

The EFIS software revision defines the compatible database part numbers. Table 2.1 lists EFIS equipment hardware part numbers and compatible EFIS software revisions. EFIS equipment examples, identifying characteristics, hardware part number locations, and software revision identification are provided in Appendix 1.

**Table 2.1 EFIS Hardware and Software**

Make <sup>[2]</sup>	Model <sup>[2]</sup>	Hardware Part Number	Software Revision
IDU-I	IDU-I	ID-A1 <sup>[3]</sup> IUA[ ][ ]I/P-SI <sup>[3]</sup> 42-023001-[ ] <sup>[3]</sup>	5.0C and later
IDU-III <sup>[1]</sup>	IDU-III <sup>[1]</sup>	EXP-045500-0101 <sup>[3]</sup> 401-045500-[ ]	5.0C and later
IDU-IV <sup>[2]</sup>	IDU-450	42-024001-[ ]	7.0A and later
IDU-IV <sup>[2]</sup>	IDU-680P	42-006001-[ ]	8.0A and later
Notes: [1] IDU-III is also called IDU-3. [2] "Series" parameter per AC 20-153A 9.b.(4)(c) is not applicable to this equipment. [3] Experimental equipment.			

## 2.3 DATABASE COMPATIBILITY BY SOFTWARE REVISION

Table 2.2 lists EFIS software revisions and compatible database part number prefixes.

**Table 2.2 Database Compatibility**

EFIS Software Revision	Jeppesen Database			
	NavData	Obstacles <sup>[1]</sup>	NavData Coverage	Database Part Number Prefix <sup>[3]</sup>
7.0C and earlier	<input checked="" type="checkbox"/>	<input checked="" type="checkbox"/>	World	CS4001
			Americas	CS4002
			International	CS4003
			Capstone <sup>[2]</sup>	CS4CAP
			Rega <sup>[2]</sup>	CS4REG
	<input checked="" type="checkbox"/>	<input type="checkbox"/>	World	CS2001
			Americas	CS2002
			International	CS2003
			Capstone <sup>[2]</sup>	CS2CAP
			Rega <sup>[2]</sup>	CS2REG
7.0D to 8.0C	<input checked="" type="checkbox"/>	<input checked="" type="checkbox"/>	World	CS3001
			Americas	CS3002
			International	CS3003
			Capstone <sup>[2]</sup>	CS3CAP
			Rega <sup>[2]</sup>	CS3REG
	<input checked="" type="checkbox"/>	<input type="checkbox"/>	World	CS1001
			Americas	CS1002
			International	CS1003
			Capstone <sup>[2]</sup>	CS1CAP
			Rega <sup>[2]</sup>	CS1REG
8.0D and later	<input checked="" type="checkbox"/>	<input checked="" type="checkbox"/>	World	CS6001
			Americas	CS6002
			International	CS6003
			Capstone <sup>[2]</sup>	CS6CAP
			Rega <sup>[2]</sup>	CS6REG
	<input checked="" type="checkbox"/>	<input type="checkbox"/>	World	CS5001
			Americas	CS5002
			International	CS5003
			Capstone <sup>[2]</sup>	CS5CAP
			Rega <sup>[2]</sup>	CS5REG

Notes: [1] Obstacle database coverage is always worldwide regardless of the NavData coverage selected.  
[2] Capstone and Rega tailored NavData coverage contains World NavData coverage.  
[3] Database part number must begin with the prefix to be compatible with the EFIS software revision.



## APPENDIX 1: EQUIPMENT IDENTIFICATION

IDU-I	
<p><b>Identifying Characteristics</b></p>	<ul style="list-style-type: none"> <li>• 4x5 inch display.</li> <li>• 8 line-select keys and 2 rotary encoders knobs at bottom.</li> <li>• SmartMedia card slot at bottom near left rotary encoder knob.</li> <li>• SmartMedia card inserted with contacts facing down.</li> <li>• Bezel cut at 45 degree angle at all corners.</li> <li>• Panel-mounted display.</li> <li>• D-sub connectors on rear.</li> </ul>
<p><b>Physical Features</b></p> <p style="text-align: center;">&amp;</p> <p><b>Hardware Part Number Location</b></p> <p>(highlighted here in red)</p>	<p style="text-align: center;">SmartMedia</p>
<p><b>EFIS Software Revision</b></p> <p>(shown on Status Page, highlighted here in red)</p>	<pre> CHELTON FLIGHT SYSTEMS  SIERRA EFIS - SV  EFIS-SV REV 6.0B-2 SOFTWARE OK (CPU NUMBER = 0) NAVIGATION DATA: COVERAGE = AMERICAS (CYCLE1204) VALID DATE 04-05-2012 EXPIRE DATE 05-03-2012 OBSTRUCTION DATA: DATE 05-03-2012 TERRAIN DATA: COVERAGE = N20W140 - N55W060 VALID DATE 07-13-2004 PRESS ANY KEY TO CONTINUE </pre>

**IDU-III**

**Identifying Characteristics**

- 4x5 inch display.
- 8 line-select keys and 2 rotary encoders knobs at bottom.
- SmartMedia card slot centered at the bottom between the rotary encoder knobs.
- SmartMedia card inserted with contacts facing up.
- Square bezel.
- Tray-mounted display.

**Physical Features & Hardware Part Number Location**  
  
(highlighted here in red)

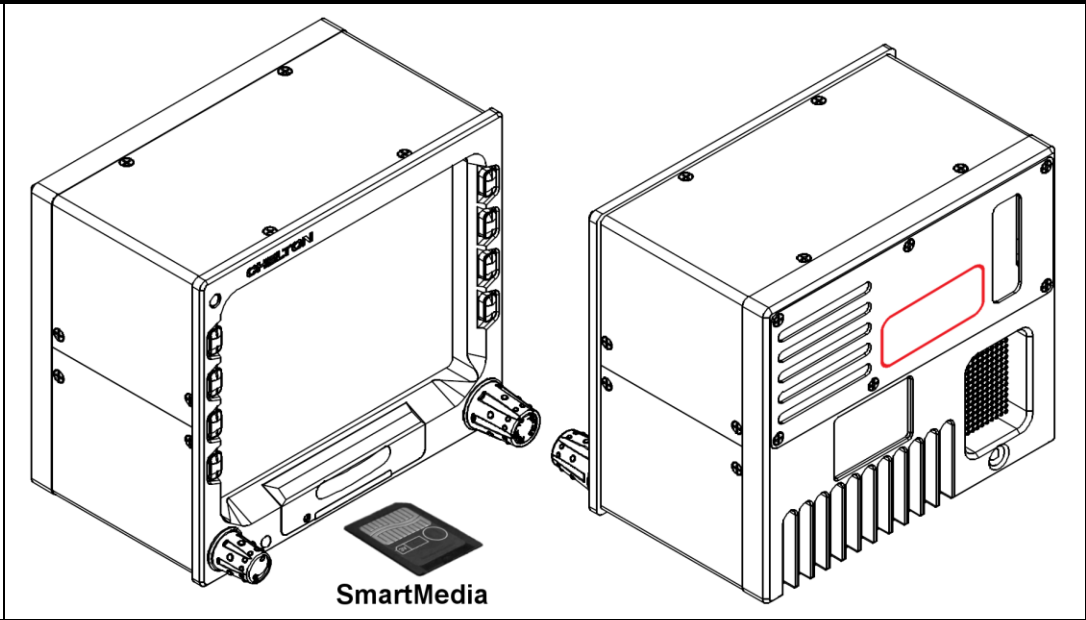

**EFIS Software Revision**  
  
(shown on Status Page, highlighted here in red)



**IDU-450**

**Identifying Characteristics**

- 4x5 inch display.
- 8 line-select keys and 2 rotary encoder knobs at bottom.
- USB port centered at the bottom between the rotary encoder knobs.
- USB port exposed when sliding the slip or non-slip housing upwards.
- Square bezel.
- Panel-mounted display.

**Physical Features & Hardware Part Number Location**  
  
(highlighted here in red)

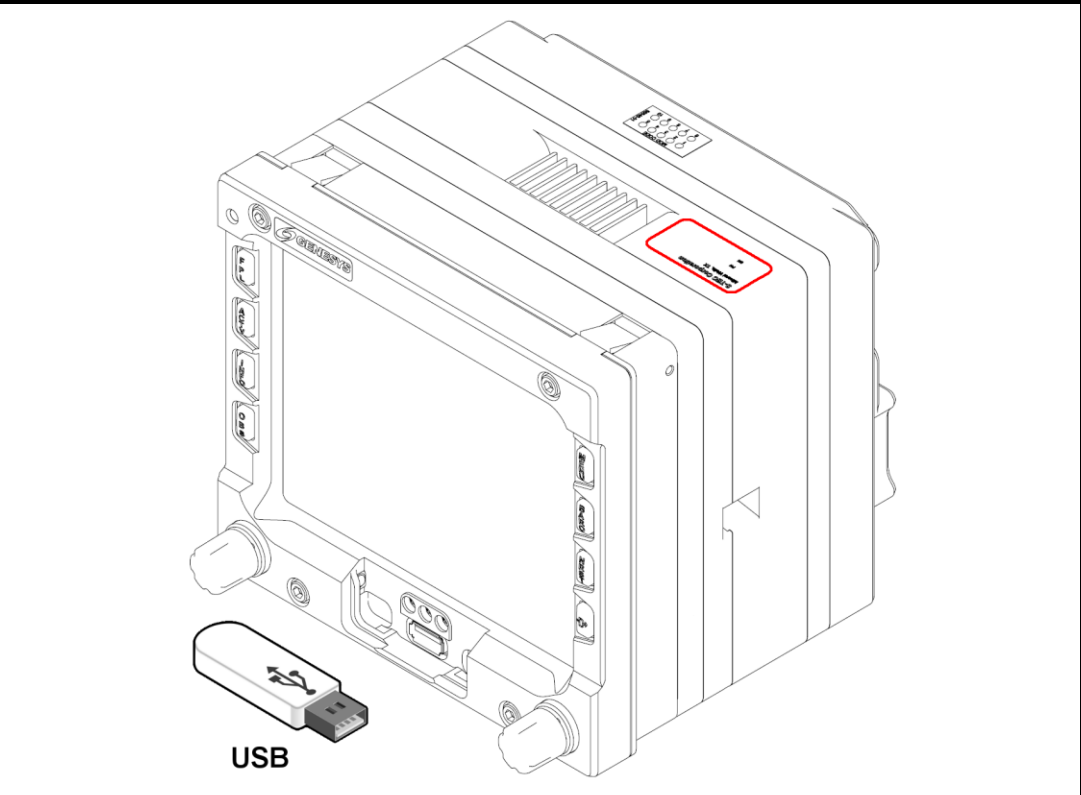

**EFIS Software Revision**  
  
(shown on Status Page along with Software Part Number, highlighted here in red)

```

REV 8.0D
P/N: 25-EFIS80D-SW-0002
SOFTWARE OK (CPU NUMBER 1)
SOFTWARE CRC = 0X3B372426
AIRCRAFT TYPE GENERIC
NAVIGATION DATA: COVERAGE = WORLD (CYCLE1601)
VALID DATE 01-07-2016
EXPIRE DATE 02-04-2016
OBSTRUCTION DATA: DATE 02-04-2016
TERRAIN DATA: COVERAGE = S75W180 - N75E181
VALID DATE 05-26-2007
PRESS ANY KEY TO CONTINUE
    
```

**IDU-680**

**Identifying Characteristics**

- 6x8 inch display.
- 16 line-select keys and 4 rotary encoder knobs at bottom.
- USB port centered at the bottom between the inner rotary encoder knobs.
- USB port exposed when sliding the slip or non-slip housing upwards.
- Rectangular bezel.
- Panel-mounted display.

**Physical Features**

&

**Hardware Part Number Location**

(highlighted here in red)

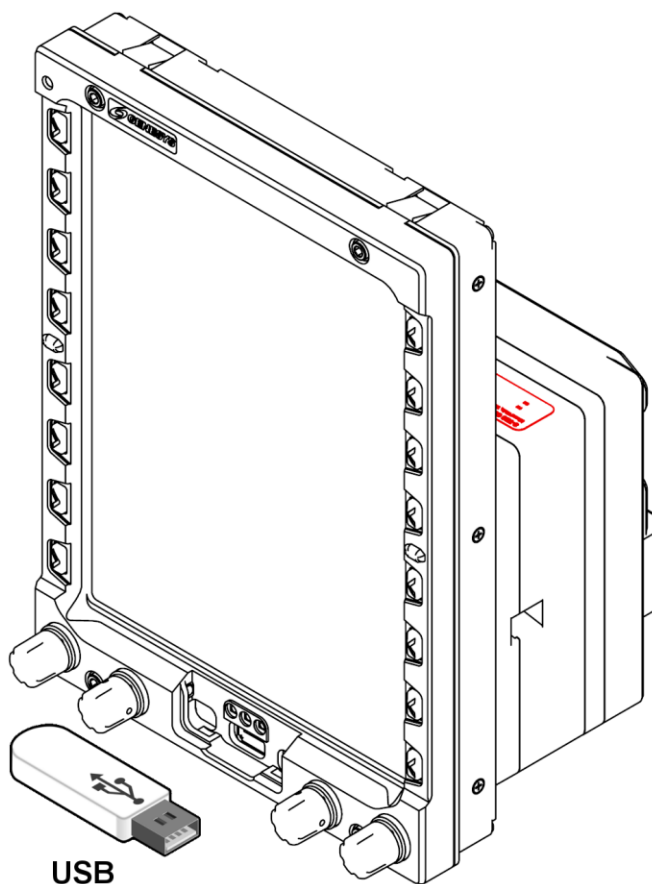

**EFIS Software Revision**

(shown on Status Page along with Software Part Number, highlighted here in red)

```
REV 8.0D
P/N: 25-EFIS80D-SW-0003
SOFTWARE OK (CPU NUMBER 1)
SOFTWARE CRC = 0X3B372426
AIRCRAFT TYPE GENERIC
NAVIGATION DATA: COVERAGE = WORLD (CYCLE1601)
VALID DATE 01-07-2016
EXPIRE DATE 02-04-2016
OBSTRUCTION DATA: DATE 02-04-2016
TERRAIN DATA: COVERAGE = S75W180 - N75E181
VALID DATE 05-26-2007
PRESS ANY KEY TO CONTINUE
```