

3D SYNTHETIC
VISION EFIS



HIGHWAY-
IN-THE-SKY
NAVIGATION



GRAPHICAL
FLIGHT
MANAGEMENT
SYSTEM

INTEGRATED
AUDIO/RADIO
MANAGEMENT

IDU-450 Version 8.0D Pilot Guide (Rotorcraft)

Pilot Operating Guide and Reference

Document 64-000102-080D

(Rotorcraft)

EFIS Software Version 8.0D

© 2016

Genesys Aerosystems

All Rights Reserved

No part of this document may be reproduced in any form, or by any means, without prior written consent of Genesys Aerosystems.

FlightLogic and Virtual VFR are trademarks of Genesys Aerosystems.

All other brand names and trademarks are the property of their respective holders.

One S-TEC Way, Municipal Airport, Mineral Wells TX. 76067

Phone: (800) 872-7832 Fax: (940) 325-3904

www.genesys-aerosystems.com

Table of Contents

Section 1	Introduction	1-1
1.1.	Introduction	1-5
1.2.	EFIS/FMS Description	1-6
1.3.	Run Demonstrator/Training Application	1-8
1.4.	EFIS Training Tool.....	1-9
1.5.	About This Guide.....	1-10
Section 2	System Overview.....	2-1
2.1.	Abbreviations and Acronyms.....	2-4
2.2.	System Overview.....	2-15
2.2.1.	IDU Initialization.....	2-15
2.3.	General Arrangement	2-19
2.3.1.	GPS Aiding Limitation.....	2-20
2.4.	Color Conventions	2-20
2.5.	Warning/Caution/Advisory System	2-23
2.6.	Database and Software Updates	2-50
2.6.1.	Navigation and Obstruction Database.....	2-50
2.6.2.	Update Requirements.....	2-51
2.6.3.	Terrain Database Update	2-54
Section 3	Display Symbology	3-1
3.1.	Introduction	3-16
3.2.	PFD (PFI) Symbology.....	3-16
3.2.1.	IDU-450 PFD Display	3-17
3.2.2.	IDU-450 PFD Display (Basic Mode).....	3-18
3.2.3.	IDU-450 MFD Display.....	3-19
3.3.	Menu Functions	3-20

3.3.1.	Selecting BARO	3-21
3.3.2.	Selected Altitude Sub-Mode (Target Altitude)....	3-22
3.3.3.	VNAV Sub-Mode	3-23
3.3.4.	Altitude Display (VNAV Tile)	3-25
3.3.5.	Altitude Display (Metric Units)	3-25
3.4.	PFD Symbology	3-25
3.4.1.	Minimum Altitude	3-27
3.4.2.	Vertical Speed Indicator	3-27
3.4.3.	Normal AGL Indication	3-30
3.4.4.	Analog AGL Indication.....	3-31
3.4.5.	Decision Height	3-32
3.4.6.	Airspeed Display	3-33
3.4.7.	Airspeed Display (With EFIS-Coupled)	3-35
3.4.8.	AW-109SP Airspeed Display	3-36
3.4.9.	Dynamically Calculated VNE	3-37
3.4.10.	Heading Display	3-37
3.4.11.	Heading Display (AW-109SP).....	3-39
3.4.12.	Pitch Scale	3-39
3.4.13.	Pitch and Roll Scale (AW-109SP).....	3-40
3.4.14.	Turn Rate Indicator.....	3-41
3.4.15.	Basic Mode.....	3-41
3.4.16.	Unusual Attitude Mode	3-42
3.4.17.	PFD Background	3-43
3.4.18.	Flight Path Marker (Velocity Vector)	3-49
3.5.	Hover Vector	3-52
3.6.	Bank Angle Scale	3-53

- 3.6.1. Turn Indication3-54
- 3.7. Timer Indication3-54
- 3.8. Marker Beacon Symbology3-54
- 3.9. Flight Director Symbology (FD1 Single Cue)3-55
 - 3.9.1. Flight Director Symbology (FD2 Dual Cue)3-56
- 3.10. Landing Gear Indication3-57
- 3.11. Course Deviation Indicator3-58
- 3.12. Course Deviation Indicator (AW-109SP).....3-60
 - 3.12.1. OBS Setting of CDI.....3-61
 - 3.12.2. Heading/Roll-Steering Sub-Mode.....3-61
- 3.13. No Autopilot or Fully-Integrated Autopilot Course Deviation Indicator3-62
 - 3.13.1. Vertical Deviation Indicator3-62
 - 3.13.2. Vertical Deviation Indicator (AW-109SP)3-65
 - 3.13.3. Vertical Deviation Indicator (EFIS Coupled)3-67
 - 3.13.4. Highway in the Sky/Skyway.....3-67
 - 3.13.5. Highway in the Sky (AW-109SP).....3-68
 - 3.13.6. Active Waypoint and Waypoint Identifier3-68
 - 3.13.7. Mini Map3-70
 - 3.13.8. Mini Map and Active Waypoint Information Block (AW-109SP)3-70
 - 3.13.9. Traffic Thumbnail3-72
 - 3.13.10. Traffic Display Definitions3-72
 - 3.13.11. Traffic Rendering Rules3-72
 - 3.13.12. Runways3-74
 - 3.13.13. Heliports.....3-76
 - 3.13.14. AFCS Annunciations (AW-109SP)3-77

3.13.15.	PFD in Command Arrow (AW-109SP).....	3-78
3.13.16.	FMS LNAV and FMS VNAV Submode Annunciations (AW-109SP).....	3-78
3.13.17.	AFCS Caution Alert Messages (AW-109SP) .	3-79
3.13.18.	Link Fail Message (AW-109SP).....	3-79
3.13.19.	Cyclic Cue (AW-109SP).....	3-80
3.13.20.	Collective Cue and Symbol (AW-109SP).....	3-80
3.13.21.	Horizon Synchronization (AW-109SP).....	3-81
3.13.22.	Decision Height and Radar Height Readout (AW-109SP)	3-82
3.14.	MFD Screen requirements (AW-109SP).....	3-82
3.14.1.	ND SCREEN	3-82
3.14.2.	Compass Rose Symbols (AW-109SP).....	3-83
3.14.3.	HSI Overlay (AW-109SP).....	3-83
3.14.4.	Active Leg of Active Flight Plan Path/Active Waypoint/Manual Course (AW-109SP)	3-83
3.14.5.	Identifier, Bearing, Distance and Time to Active Waypoint (AW-109SP).....	3-84
3.14.6.	Swiss Grid (AW-109SP).....	3-84
3.15.	Navigation Display Symbology.....	3-85
3.15.1.	Basic Moving Map.....	3-85
3.15.2.	Ownship Symbology.....	3-86
3.15.3.	Compass Rose/ND Boundary Circle Symbol.....	3-86
3.15.4.	Moving Map with Instrument Approach.....	3-86
3.15.5.	North-Up Arc Mode	3-87
3.15.6.	North-Up Centered Mode.....	3-87
3.15.7.	Heading-Up Centered Mode	3-88
3.15.8.	Air Data and Groundspeed	3-88

- 3.16. Conventional HSI/PTR Format.....3-89
 - 3.16.1. Compass Rose Symbols3-92
 - 3.16.2. HSI Screen (AW-109SP).....3-94
 - 3.16.3. Compass Rose Symbols (AW-109SP).....3-94
 - 3.16.4. Vertical Deviation Indicator (AW-109SP)3-95
 - 3.16.5. Primary NAV Pointer (AW-109SP)3-95
 - 3.16.6. NAV Preview Pointer (AW-109SP).....3-95
 - 3.16.7. Identifier, Bearing, Distance and Time to Active Waypoint (AW-109SP)3-96
 - 3.16.8. Fuel Totalizer/Waypoint Bearing and Distance Functions3-96
 - 3.16.9. Clock/Timers/Options3-98
- 3.17. Navigation Log.....3-100
 - 3.17.1. Clock and Groundspeed3-100
 - 3.17.2. Fuel Remaining and Fuel Flow Data3-100
 - 3.17.3. Waypoint Identifier Column3-101
 - 3.17.4. VNAV and VNAV Offset Column3-102
 - 3.17.5. Path Column3-102
 - 3.17.6. Distance Column3-103
 - 3.17.7. Estimated Time Enroute Column.....3-103
 - 3.17.8. Estimated Time of Arrival Column3-103
 - 3.17.9. Fuel Remaining Column3-104
- 3.18. Start Point.....3-104
- 3.19. Altitude Capture Predictor3-105
 - 3.19.1. Top of Descent3-105
 - 3.19.2. Projected Path3-106
- 3.20. Active Flight Plan Path/Manual Course/Runways3-106

3.21.	FOV Indication.....	3-107
3.22.	Range.....	3-107
3.23.	Navigation Data.....	3-108
3.23.1.	Air Data and Groundspeed	3-110
3.23.2.	Analog Navigation Symbology	3-111
3.23.3.	Borders.....	3-112
3.23.4.	Terrain/Obstructions.....	3-112
3.24.	Pan Mode.....	3-114
3.25.	HSI Screen.....	3-115
3.25.1.	HSI Screen VDI.....	3-115
3.25.2.	Analog Navigation Symbology	3-116
3.25.3.	HSI with Marker Beacon Displayed Air Data and Groundspeed	3-117
3.25.4.	Clock/Timers/Options.....	3-118
3.25.5.	Fuel Totalizer/Waypoint Bearing and Distance Functions	3-119
3.26.	WX-500 Data.....	3-119
3.26.1.	Strike Screen Range	3-120
3.26.2.	Active Flight Plan Path/Manual Course/Runways.....	3-121
3.27.	Dedicated Traffic Screen.....	3-122
3.27.1.	Ownship Symbol	3-122
3.27.2.	Traffic Screen Range	3-123
3.27.3.	Compass Rose Symbols.....	3-123
3.27.4.	Active Flight Plan Path/Manual Course/Runways.....	3-123
3.27.5.	Dedicated Traffic Screen (AW-109SP)	3-124
3.27.6.	Compass Rose Symbols (AW-109SP).....	3-125

- 3.27.7. Active Leg of Active Flight Plan Path (AW-109SP) ... 3-125
- 3.27.8. Identifier, Bearing, Distance and Time to Active Waypoint (AW-109SP) 3-125
- 3.27.9. Dedicated Strike (WX-500) Screen (AW-109SP) 3-126
- 3.27.10. Active Leg of Active Flight Plan Path (AW-109SP) 3-126
- 3.27.11. Identifier, Bearing, Distance, and Time to Active Waypoint (AW-109SP) 3-126
- 3.28. Datalink Symbology 3-127
 - 3.28.1. Datalink Screen Legend 3-132
 - 3.28.2. Air Data and Groundspeed 3-132
 - 3.28.3. Clock/Timers/Options 3-132
 - 3.28.4. Datalink Screen Orientation 3-137
 - 3.28.5. Datalink Screen Range 3-137
 - 3.28.6. Boundary Circle Symbol 3-138
 - 3.28.7. Active Flight Plan Path/Manual Course/Runways 3-138
 - 3.28.8. Borders 3-139
 - 3.28.9. Pan Mode 3-139
- 3.29. Hover Screen 3-140
 - 3.29.1. Ownship Symbol 3-140
 - 3.29.2. Hover Screen Orientation 3-140
 - 3.29.3. Hover Screen Range 3-140
 - 3.29.4. Hover Vector 3-141
 - 3.29.5. Compass Rose Symbols 3-141
 - 3.29.6. Active Flight Plan Path/Manual Course 3-142

3.29.7.	Navigation Data.....	3-143
3.29.8.	Projected Path.....	3-144
3.29.9.	Air Data and Groundspeed	3-144
3.29.10.	Clock and Timer	3-144
3.29.11.	AGL Indication.....	3-145
3.29.12.	Decision Height Indication.....	3-146
3.29.13.	Hover Screen (AW-109SP).....	3-147
3.29.14.	Compass Rose Symbols (AW-109SP).....	3-147
3.30.	Hover Vector (AW-109SP).....	3-147
3.30.1.	Groundspeed Reference (AW-109SP).....	3-147
3.30.2.	A/C Acceleration Cue (AW-109SP).....	3-148
3.30.3.	Active Flight Plan Path (AW-109SP).....	3-148
3.30.4.	Air Data and Groundspeed (AW-109SP)	3-149
3.30.5.	AGL Indication.....	3-149
3.30.6.	Transition-Down Pre-Selection Bug and Readout (AW-109SP).....	3-150
3.30.7.	Identifier, Distance, and Time to MOT Waypoint (AW-109SP)	3-150
3.30.8.	Nav Log Screen (AW-109SP)	3-150
3.31.	PFD and MFD Screen Requirements (AW-109SP) .	3-151
3.31.1.	Hover Vector (AW-109SP)	3-151
3.32.	Weather Radar	3-151
3.32.1.	Weather Screen Format.....	3-152
3.32.2.	Weather Screen Range.....	3-153
3.32.3.	Track Line.....	3-154
3.32.4.	Active Flight Plan Path/Manual Course/Runways.....	3-154

3.32.5.	Weather Radar Return Data	3-155
3.32.6.	Air Data and Groundspeed	3-157
3.32.7.	Clock/Timers/Options	3-157
3.32.8.	Fuel Totalizer/Waypoint Bearing and Distance Functions	3-161
3.33.	Video Input Screen	3-161
3.33.1.	ZOOM Level	3-161
3.33.2.	Pan Mode	3-162
3.33.3.	Video Input Status Display	3-162
Section 4	Reversionary Modes.....	4-1
4.1.	Reversionary Modes.....	4-5
4.2.	System Operation in Reversionary Modes.....	4-6
4.2.1.	Oat Sensor Failure Mode	4-9
4.2.2.	Heading Failure Mode	4-10
4.2.3.	PFD Screen Auto Reversion	4-10
4.2.4.	GPS Failure	4-10
4.3.	PFD Failure Mode 0	4-13
4.3.1.	MFD Failure Mode 0 (Normal Mode).....	4-14
4.4.	PFD Failure Mode 1	4-16
4.4.1.	MFD Failure Mode 1	4-17
4.5.	PFD Failure Mode 2 (Normal Mode)	4-19
4.5.1.	MFD Failure Mode 2.....	4-20
4.6.	PFD Failure Mode 3	4-22
4.6.1.	MFD Failure Mode 3.....	4-23
4.7.	PFD Failure Mode 4	4-25
4.7.1.	MFD Failure Mode 4.....	4-26

4.8.	PFD Failure Mode 5	4-28
4.8.1.	MFD Failure Mode 5.....	4-29
4.9.	PFD Failure Mode 6	4-31
4.9.1.	MFD Failure Mode 6.....	4-32
4.10.	PFD Failure Mode 7	4-34
4.10.1.	MFD Failure Mode 7.....	4-35
Section 5	Menu Functions and Step-By-Step Procedures.....	5-1
5.1.	Menu Functions.....	5-8
5.2.	Menu Synchronization.....	5-8
5.3.	Menu Function Types.....	5-12
5.4.	Top-Level Menu	5-13
5.4.1.	IDU-450 PFD Normal Mode Top-Level Menu....	5-13
5.5.	Top-Level Menu Option Descriptions.....	5-14
5.5.1.	Top-Level Menu Soft Menu Tiles (AW-109SP)..	5-14
5.5.2.	#1 Encoder (●)	5-14
5.5.3.	Top-Level Menu Automatic Pop-up Function Descriptions	5-15
5.6.	First Page (PFD)	5-19
5.6.1.	PFD Page First-Level Option Descriptions	5-19
5.6.2.	PFD Screen First Soft Menu Level.....	5-20
5.6.3.	First-Level (MFD)	5-21
5.7.	Lower-Level Menus (Below First-Level).....	5-22
5.8.	Flight Plan (FPL) Menu	5-23
5.8.1.	Flight Planner Page.....	5-23
5.8.2.	MFD Page Shown on IDU	5-24
5.8.3.	To Create an Overfly User Waypoint	5-24

- 5.8.4. Flight Plan (FPL) Menu Selecting (Step-By-Step).....5-25
- 5.8.5. Flight Plan (FPL) Menu Create-Edit (MFD Only) (Step-By-Step).....5-26
- 5.8.6. Activate Flight Plan (MFD Only) (Step-By-Step) 5-27
- 5.8.7. Edit Flight Plan (MFD Only) (Step-By-Step).....5-28
- 5.8.8. Reverse Flight Plan (MFD Only) (Step-By-Step)5-29
- 5.8.9. Delete Flight Plan (MFD Only) (Step-By-Step)...5-30
- 5.8.10. Create User Waypoint (LAT-LON) (MFD Only) (Step-By-Step)5-30
- 5.8.11. Create User Waypoint (RAD-DST) (MFD Only) (Step-By-Step).....5-32
- 5.8.12. Edit User Waypoint (MFD Only) (Step-By-Step) 5-33
- 5.8.13. Delete User Waypoint (MFD Only) (Step-By-Step)...5-34
- 5.8.14. RAIM Prediction.....5-35
- 5.9. Active Flight Plan (ACTV) Menu.....5-37
 - 5.9.1. Main Menu5-37
 - 5.9.2. Active Flight Plan (ACTV) Menu Options5-42
 - 5.9.3. Active Flight Plan (ACTV) Menu Options (Step-By-Step)5-47
 - 5.9.4. Active Flight Plan (ACTV) Menu (Step-By-Step)5-48
 - 5.9.5. Active Flight Plan (ACTV) Options NRST Menu Option (Step-By-Step).....5-49
 - 5.9.6. Active Flight Plan (ACTV) Menu (AW-109SP) ...5-49
- 5.10. Information (INFO) Menu.....5-50
 - 5.10.1. Information (INFO) Menu (Step-By-Step).....5-52
 - 5.10.2. Information (INFO) Menu (AW-109SP)5-52
- 5.11. Omnibearing Selector (OBS) Menu.....5-53

5.11.1.	Omnibearing Selector (OBS) Menu (Step-By-Step) .	5-54
5.11.2.	Omnibearing Selector (OBS) Menu (AW-109SP).....	5-54
5.12.	Heading Bug (HDG) Menu	5-55
5.12.1.	Heading Bug (HDG) Menu (PFD Only) (Step-By-Step)	5-55
5.12.2.	Heading Bug (HDG) Menu (AW-109SP).....	5-55
5.13.	Nearest (NRST) Menu	5-56
5.13.1.	Nearest (NRST) Menu (Step-By-Step).....	5-58
5.13.2.	Nearest ILS (NRST) Menu (Step-By-Step)	5-59
5.14.	Direct Menu	5-60
5.14.1.	Direct Menu (Step-By-Step)	5-62
5.15.	Timer (TIMER) Menu.....	5-63
5.15.1.	Timer (TIMER) Menu (Step-By-Step).....	5-64
5.16.	PFD Source (SOURCE) Menu	5-65
5.16.1.	PFD Page First-Level Source Selection (Step-By-Step)	5-66
5.17.	PFD Bugs (BUGS) Menu (N/A for AW-109SP).....	5-67
5.17.1.	PFD Bugs (BUGS) Menu (Step-By-Step)	5-70
5.18.	PFD Bugs (BUGS) Menu (AW-109SP).....	5-71
5.19.	Remote Bugs Panel	5-72
5.20.	Remote Bugs Panel (AW-109SP).....	5-75
5.20.1.	Heading Encoder.....	5-75
5.20.2.	Altitude Encoder (AW-109SP).....	5-76
5.20.3.	Multifunction Encoder.....	5-76
5.20.4.	LNAV Button (AW-109SP)	5-77
5.20.5.	VNAV Button (AW-109SP).....	5-77

- 5.21. PFD Declutter (DCLTR) Menu.....5-78
 - 5.21.1. PFD Declutter (DCLTR) Menu (Step-By-Step)...5-80
- 5.22. PFD Declutter (DCLTR) Menu (AW-109SP)5-81
- 5.23. PFD Altimeter Menu5-82
 - 5.23.1. PFD Altimeter Menu (Step-By-Step)5-83
- 5.24. MFD Fault Display (FAULTS) Menu.....5-84
 - 5.24.1. MFD Fault Display (FAULTS) Menu (Step-By-Step).
.....5-87
- 5.25. MFD FUEL Totalizer Quantity Setting (SET FUEL) MENU
.....5-87
 - 5.25.1. MFD Fuel Totalizer Quantity Setting (SET FUEL)
Menu (AW-109SP)5-88
- 5.26. MFD Page.....5-88
 - 5.26.1. MFD Page (PAGE) Menu (Step-By-Step)5-89
 - 5.26.2. MFD NAV Log Page5-90
 - 5.26.3. MFD ND Page Format (FORMAT) Menu5-91
 - 5.26.4. MFD ND Page Format (FORMAT) Menu (Step-By-
Step)5-94
 - 5.26.5. MFD HSI Page.....5-95
 - 5.26.6. MFD HSI Pointer (PTRS) Menu5-96
 - 5.26.7. MFD Strike Format (FORMAT) Menu.....5-97
 - 5.26.8. MFD Traffic Format (FORMAT) Menu.....5-98
 - 5.26.9. MFD Datalink Format (FORMAT) Menu.....5-99
 - 5.26.10. MFD Video Input Format (FORMAT) Menu .5-100
- Section 6 Quick Start Tutorial.....6-1
- Section 7 IFR Procedures.....7-1
 - 7.1. IFR Procedures7-6
 - 7.2. Overview of Procedures and Instrument Approaches..7-6

7.2.1.	Vertical Deviation Indicator Linear Limits	7-8
7.2.2.	Highway in the Sky (Skyway)	7-8
7.2.3.	Waypoint Sequencing	7-13
7.2.4.	Fly-Over Waypoints	7-14
7.2.5.	Fly-By Waypoints	7-16
7.2.6.	Direct-To	7-21
7.3.	Magnetic Course	7-21
7.3.1.	AHRS Modes for Heading Source	7-22
7.3.2.	GPS Altitude	7-22
7.3.3.	Dead Reckoning	7-22
7.3.4.	Geodesic Path Computation Accuracy	7-23
7.3.5.	Parallel Offsets	7-23
7.4.	Default GPS/SBAS Navigation Modes	7-25
7.5.	GPS/SBAS CDI Scale	7-28
7.6.	Approach Type Selection	7-29
7.6.1.	Approach Path Definition	7-31
7.7.	VTF IFR Approach	7-31
7.8.	VTF VFR Approach	7-32
7.9.	Missed Approach and Departure Path Definition	7-32
7.10.	Loss of Navigation Monitoring	7-33
7.11.	Discontinuities	7-34
7.12.	Selection of an Instrument Procedure	7-34
7.12.1.	Standard Instrument Departure (SID)	7-36
7.12.2.	Standard Terminal Arrival Route (STAR)	7-38
7.12.3.	ILS Instrument Approach	7-40
7.12.4.	LOC Back Course Instrument Approach	7-45

- 7.12.5. RNAV (GPS) Instrument Approach to LPV Minima... 7-49
- 7.13. Copter RNAV (GNSS) Approach..... 7-52
 - 7.13.1. NRST ILS Instrument Approach..... 7-57
 - 7.13.2. VOR/DME Instrument Approach 7-62
 - 7.13.3. Copter RNAV (GPS) Instrument Approach 7-66
- Section 8 Terrain Awareness Warning System 8-1
 - 8.1. Enhanced HTAWS and HTAWS (Terrain Awareness Warning System) Functions 8-4
 - 8.1.1. Terrain Display 8-5
 - 8.2. Forward Looking Terrain Alert Function 8-5
 - 8.2.1. FLTA Modes 8-6
 - 8.2.2. GPS/SBAS Navigation Mode Slaving..... 8-6
 - 8.2.3. Default FLTA Mode 8-6
 - 8.3. FLTA Search Envelope 8-8
 - 8.3.1. FLTA Search Volume..... 8-11
 - 8.3.2. FLTA Alerts and Automatic Popup..... 8-11
 - 8.4. Excessive Closure Rate to Terrain (GPWS Mode 2) . 8-14
 - 8.5. Sink Rate after Takeoff or Missed Approach (GPWS Mode 3) 8-16
 - 8.6. Flight into Terrain when not in Landing Configuration (GPWS Mode 4) 8-17
 - 8.7. Excessive Downward Deviation from an ILS Glideslope (GPWS Mode 5) 8-18
 - 8.8. External Sensors and Switches 8-20
 - 8.9. TAWS System Basic Parameter Determination 8-22
 - 8.10. TAWS Automatic Inhibit Functions (Normal Operation) 8-27

8.10.1. TAWS Automatic Inhibit Functions (Abnormal Operation)	8-27
8.10.2. TAWS Manual Inhibit Functions	8-30
8.11. TAWS Selections on PFD	8-30
Section 9 Appendix	9-1
9.1. Appendix	9-5
9.2. Operating Tips	9-5
9.3. Domestic or International Flight Planning	9-5
9.4. Descent Planning.....	9-5
9.4.1. Terrain Clearance.....	9-5
9.4.2. Departure Airport Information	9-6
9.4.3. Unique Names for Flight Plans.....	9-6
9.4.4. Altimeter Settings	9-6
9.4.5. Warnings, Cautions, and Advisories	9-6
9.5. Magnetic vs. True North Modes of Operation	9-7
9.6. Altitude Miscompare Threshold	9-8
9.7. Airspeed Miscompare Threshold.....	9-9
9.8. Jeppesen NavData Chart Compatibility	9-11
9.9. ARINC 424 Path-Terminator Leg Types	9-12
9.10. Data Logging and Retrieval	9-18
9.11. Log Files.....	9-18
9.11.1. Delete LOG Files.....	9-18
9.12. Routes and Waypoints	9-18
9.12.1. VFR Flight Planning	9-18
9.12.2. Download Routes and User Waypoints	9-19
9.13. EFIS Training Tool (ETT).....	9-19

9.14.	Upload Routes and User Waypoints	9-19
9.14.1.	Delete Routes	9-20
9.15.	USB External Drive Memory Limitations.....	9-20
9.16.	Service Difficulty Report.....	9-21
9.17.	Certification Basis	9-22
9.18.	Environmental Requirements	9-24

INDEX

GLOSSARY

Section 1 Introduction

Revision Record

Rev	Notes	Date	Author

Table of Contents

SECTION 1	INTRODUCTION	1-1
1.1.	INTRODUCTION	1-5
1.2.	EFIS/FMS DESCRIPTION.....	1-6
1.3.	RUN DEMONSTRATOR/TRAINING APPLICATION	1-8
1.4.	EFIS TRAINING TOOL	1-9
1.5.	ABOUT THIS GUIDE.....	1-10

List of Figures and Tables

FIGURE 1-1: IDU-450 INPUT IDENTIFICATION	1-6
FIGURE 1-2: IDU-450 PRIMARY FLIGHT DISPLAY (PFD).....	1-7
FIGURE 1-3: IDU-450 MULTIFUNCTION DISPLAY (MFD)	1-8
FIGURE 1-4: INITIALIZATION SCREEN	1-8

1.1. Introduction

In the last two decades, aviation has become more and more complex; as a result, cockpit resources have followed the commercial carriers' trend toward "automation centered" systems. These sophisticated systems minimize pilot involvement and automate control of the aircraft and its systems to the greatest extent possible, thereby relegating the pilot to the role of manager and emergency backup. Examples are flight directors and fly-by-wire systems where the pilot is removed from the information loop.

The Genesys Aerosystems EFIS installed in this aircraft was conceived and designed as a "pilot-centered" system. While still highly automated, this type of system, common in other military tactical applications, presents the pilot with information necessary to make decisions about the flight and take the appropriate actions. A good example is the Highway-In-The-Sky (HITS), which allows for highly automated approaches, but its predictive nature provides the pilot unprecedented awareness of upcoming maneuvers. Contrary to the traditional idea of overloading the pilot with information and options, this Genesys Aerosystems EFIS clearly and concisely presents only necessary information which reduces pilot workload while greatly decreasing task complexity as it minimizes confusion. The result is safer flying with less stress and fatigue.

The Genesys Aerosystems EFIS Flight Logic goal is IFR-VFR equivalence and the basic concept of the FlightLogic EFIS is proven HUD symbology overlaying a real-time 3-D virtual reality view of the outside world. The resulting "synthetic vision" provides the pilot in IMC with the same simple visual clues for navigation and aircraft control as those used in VFR conditions. This "virtual VFR" eliminates the need to scan multiple instruments for aircraft control or mentally interpret complicated enroute and approach procedures. As experience is gained with this advanced integrated system, each pilot will fly with more precision, awareness, and confidence.

1.2. EFIS/FMS Description



Figure 1-1: IDU-450 Input Identification

The IDU (Integrated Display Unit) is manufactured from machined, anodized aluminum and has eight pushbuttons along the vertical sides with dedicated buttons with imprinted legends.

There are two encoders along the bottom with the left encoder only controlling the backlighting intensity. Neither encoder has an auto-repeat feature, but the right-hand encoder controls the heading menu on the PFD or map scale on the MFD.

References in Section 5 Menu Functions and Step-By-Step Procedures refer to the right encoder as “#1 Encoder” (1) to push and or scroll for desired outcomes. Between the two encoders on the bezel, a USB port with provisions for a slip indicator or blank housing act as a movable door. When this door is lifted, an optical switch initiates the Ground Maintenance Mode necessary for gaining access to the maintenance program once a USB memory is inserted.

The IDU bezel includes an ambient light sensor located on the front face to measure ambient light levels. This is used only to set

backlight illumination levels. The brightness control independently controls the panel and display lighting brightness. Panel lighting refers to the illumination of legends, buttons, and encoders (push and scroll clockwise to increase and counter clockwise to decrease). Display lighting refers to the illumination of the LCD display (without pushing and as described with panel lighting). This lighting may be controlled locally or remotely with a default state being with the local control.

NOTE:

If attempting to enter the Ground Maintenance mode with bright light shining directly on the display, shield the light sensor if necessary.

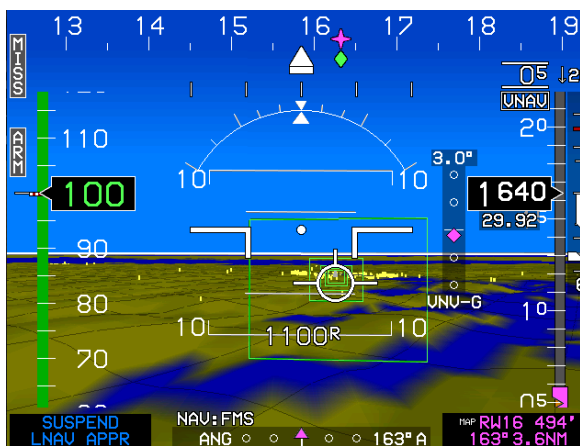


Figure 1-2: IDU-450 Primary Flight Display (PFD)

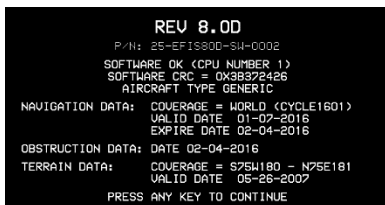


Figure 1-3: IDU-450 Multifunction Display (MFD)

1.3. Run Demonstrator/Training Application

Using the built in Demonstration Application, the EFIS may be used to fly anywhere in the world while performing any procedure (except takeoff and landing) based on the current Jeppesen Navigation database. To use this feature:

- 1) With power off, lift the USB Memory Flash Door. Insert a USB Flash Memory Storage Device in the IDU lower bezel.
- 2) Power the system on and use encoder **1** (scroll and push to enter) to select the **RUN DEMONSTRATION/TRAINING APPLICATION** option.



Other Rotorcraft



AW-109SP

Figure 1-4: Initialization Screen

The demonstrator allows the pilot to gain familiarity of the EFIS menu structure and location of button tiles for each operation. Load an instrument procedure prior to take off to view the sequence of events to be expected with the aircraft flying the same speeds normally flown as read from the preset limits.

The demonstrator program automatically begins flying over Reno, Nevada, USA. The altitude begins at approximately 7900' MSL and may be changed with the use of the menu and target altitude control. The airspeed remains relatively constant but may be controlled through the use of the Airspeed IAS bug in the BUGS menu (N/A AW-109SP). The simulated aircraft may be positioned anywhere in the world due to the worldwide terrain database loaded in the system by activating a flight plan stored in the memory. However, the Jeppesen navigation database must be updated to match the area of the world navigation as anticipated since worldwide terrain is loaded.

All appropriate navigation signals are simulated, allowing for precision and non-precision instrument approaches found within the current navigation database. All obstructions in the latest obstruction database and all Caution, Warning, and Advisory System aural and flag annunciations are presented as appropriate during the simulated demonstration flights. During operation in this mode, each IDU operates independently of all sensors, Remote Bugs panel, and other displays.

In addition to the demonstrator program, a training tool is available to load on a personal computer for purposes of flying like the aircraft.

1.4. EFIS Training Tool

The EFIS Training Tool (ETT) is an application entirely based on the EFIS code and is compatible with 32- or 64-bit versions of Microsoft Windows®. It serves as a multi-purpose tool for training pilots and provides features to record and capture images. This tool may be used to create routes and user waypoints for saving and uploading into the aircraft mounted IDUs. The ETT has a bezel with simulated buttons and encoders responsive to mouse and external keyboard messages. Bezel graphics are derived from actual bezel design data, and the ETT presents an active display with 1:1 pixel correspondence to an actual IDU display. The audio output capability for the ETT matches the audio functionality in the actual IDU. This Training Tool simulates the functionalities of the IDU-450, which begins flight in Reno, Nevada at approximately 7900' MSL.

An alternate method of Training Tool initialization is available at any altitude, speed, and wind conditions anywhere in the world through the simulate.ini program loaded into the computer root directory. See Section 9 Appendix in for further details.

Flight plans may be created (on the MFD only), stored, and activated in the same manner as on the EFIS displays installed in the aircraft. This allows for moving the start point to anywhere in the world where loaded NavData is present for practicing published procedures. All applicable nav signals are simulated with localizer signals found on VLOC1 and VOR signals found on VLOC2. Once the start position has been moved from Reno, Nevada, the aircraft begins flying at approximately 7900' MSL intercepting the first leg at a 45° angle.

1.5. About This Guide

The operation of the Genesys Aerosystems EFIS and FMS is described in great detail and divided into nine sections as follows:

TABLE OF CONTENTS

Use this section to locate areas by topic...

INTRODUCTION (Section 1)

Use this section to gain basic understanding of how this pilot guide is constructed and where to begin...

SYSTEM OVERVIEW (Section 2)

This section provides a basic system description and block diagram; operational warnings, acronyms and abbreviations; coloring conventions; and detailed descriptions of the EFIS hardware. This section contains the Warning, Caution, and Advisory table describing annunciations for each category, where the flag appears, and on which position of each display under identified conditions.

Use this section to gain better understanding of the system and learn terminology, abbreviations, acronyms, and what the warnings, cautions, and advisories mean. This is where a basic description of all encoder and button functions and coloring conventions are introduced with menu tile definitions, as well as, database updating procedures and how the IDU behaves during initialization...

DISPLAY SYMBOLOGY (Section 3)

This section provides identification of each screen element of the PFD and MFD. For each separate screen, every element of the symbology is identified on a sample screen. Immediately following the sample screens, all elements for that screen are listed.

Use this section to gain familiarity and understand what symbology to anticipate and define after viewing for every possible PFD and ND presentation...

REVERSIONARY MODES (Section 4)

This section provides views of the IDU-450 displays with various sensor failed conditions and resulting symbology. Examples of various configurations and display formats used with specific tables showing affected functions affected.

Use this section to understand what to expect when a particular sensor fails and what changes on the display immediately or after a specified amount of time...

MENU FUNCTIONS AND STEP-BY-STEP PROCEDURES (Section 5)

This section shows a flow diagram and selection options with step-by-step procedures for each configured possibility with this EFIS system.

Use this section for understanding the menu structure of each feature and how to go step-by-step during operation of each specific task...

QUICK START TUTORIAL (Section 6)

This section provides the basics necessary for flying a familiarization flight with this system. With a few simple steps, an active waypoint may be created, and the view may be controlled to manage the displays for the existing flight conditions.

Use this section to quickly gain familiarity with where to locate controls to manipulate the system for each operation...

IFR PROCEDURES (Section 7)

This section provides detailed information and instruction about selecting and flying instrument procedures found within the Jeppesen navigation database.

Use this section to gain familiarity with selection of departure procedures, standard terminal arrival procedures and published instrument approach procedures. This section describes how ATC clearances may often change and how the active flight plan quickly reflects these changes. Additionally, this section defines every example of the most popular of all published procedures with views of referenced published procedures...

TERRAIN AWARENESS WARNING SYSTEM (Section 8)

This section contains a description of the TSO-C194 Enhanced HTAWS and HTAWS functionality for this rotorcraft with all configurations.

Use this section for understanding the HTAWS functions provided for the various phases of flight in addition to the call-outs for each GPWS Mode as described in detail for all possible configurations. This section defines the various parameters which automatically apply to each mode of flight...

APPENDIX (Section 9)

This section contains support material and other useful information about system operation, ancillary guidance from Jeppesen, and supplemental information.

Use this section for understanding naming conventions used by the navigation database provider and flight data recorded information format; downloading routes and user waypoints; and sourcing a copy of the Service Difficulty Report form...

INDEX

The Index provides an alphabetical listing of terms used in the pilot guide with corresponding page numbers.

Use this section to lookup key words and locate where at least one or more instances are used in the text.

GLOSSARY

The Glossary provides an alphabetical listing of definitions for terms used in the pilot guide.

Use this index to look up definitions for key words and terms.

Genesys Aerosystems is committed to producing the highest quality product possible and we welcome comments and suggestions concerning this publication. Please e-mail comments and suggestions to:

genesys-support@genesys-aerosystems.com

or

genesys-support@s-tec.com

If you encounter problems with the operation of your Genesys Aerosystems EFIS, please complete and return the Service Difficulty Report in Section 9 Appendix directly to:

Genesys Aerosystems

One S-Tec Way

Mineral Wells Municipal Airport

Mineral Wells, Texas 76067 or Fax: (940) 325-3904

Section 2 System Overview

Table of Contents

SECTION 2	SYSTEM OVERVIEW	2-1
2.1.	ABBREVIATIONS AND ACRONYMS	2-4
2.2.	SYSTEM OVERVIEW	2-15
2.2.1.	<i>IDU Initialization</i>	2-15
2.3.	GENERAL ARRANGEMENT	2-19
2.3.1.	<i>GPS Aiding Limitation</i>	2-20
2.4.	COLOR CONVENTIONS.....	2-20
2.5.	WARNING/CAUTION/ADVISORY SYSTEM	2-23
2.6.	DATABASE AND SOFTWARE UPDATES	2-50
2.6.1.	<i>Navigation and Obstruction Database</i>	2-50
2.6.2.	<i>Update Requirements</i>	2-51
2.6.3.	<i>Terrain Database Update</i>	2-54

List of Figures and Tables

FIGURE 2-1: SYSTEM DIAGRAM	2-15
TABLE 2-1: IDU INITIALIZATION SOFTWARE VERSION AND PART NUMBERS.....	2-16
FIGURE 2-2: INITIALIZATION SCREEN.....	2-19
FIGURE 2-3: PRIMARY IDU-450 PFD.....	2-20
TABLE 2-2: WARNINGS, CAUTIONS, AND ADVISORIES	2-23
TABLE 2-3: ANNUNCIATIONS PRIORITY.....	2-50
FIGURE 2-4: GROUND MAINTENANCE PAGE	2-51
FIGURE 2-5: IDU-450 STARTUP SCREEN.....	2-53

2.1. Abbreviations and Acronyms

AC	Advisory Circular
AD	Airworthiness Directive
A-D	Analog to Digital (converter)
ADAHRS	Air Data Attitude Heading Reference System
ADC	Air Data Computer
ADF	Automatic Direction Finder
ADS-B	Automatic Dependent Surveillance-Broadcast
AFCS	Automatic Flight Control System
AFM	Aircraft Flight Manual
AGL	Above Ground Level
AHRS	Attitude Heading Reference System
AIRAC	Aeronautical Information Regulation and Control
AIRMET	Airmen's Meteorological Information
ALTA	Equal to "Selected Altitude Submode" (AW 109SP)
AMLCD	Active Matrix Liquid Crystal Display
ANSI	American National Standards Institute
APV	Approach with Vertical Guidance
ARINC	Aeronautical Radio, Inc.
ARP	SAE Aerospace Recommended Practice
AS	SAE Aerospace Standard
ASEL	Aircraft Selected Altitude
ATA	AT Attachment (hard disk storage interface)
ATC	Air Traffic Control
CA	Course to Altitude
CD	Course to DME Distance

CDI	Course Deviation Indicator
CDR	Critical Design Review
CDTI	Cockpit Display of Traffic Information
CM	Configuration Management
CNS	Communications/Navigation/Surveillance
COM	Communication
CPM	Company Project Manager
CPM	Computer Processor Module
CPU	Central Processing Unit
CR	Change Request
CR	Course to Radial Termination
CRC	Cyclic Redundancy Check
CSA	Conflict Situation Awareness (ADS-B)
DA	Decision Altitude
D-A	Digital to Analog (converter)
DAICD	Digital Aeronautical Information CD
DAR	Designated Airworthiness Representative
DCN	Document Change Notice
DEM	Digital Elevation Model
DER	Designated Engineer Representative
DH	Decision Height
DL	Data Link
DME	Distance Measuring Equipment
DMIR	Designated Manufacturing Inspection Representative
DO	RTCA Document
DOD	Department of Defense

DOF	Digital Obstruction File
DP	Departure Procedure
DR	Dead Reckoning or Defect Report
DSP	Digital Signal Processing
EFIS	Electronic Flight Instrument System
EGNOS	European Geostationary Navigation Overlay Service
EGPWS	Enhanced Ground Proximity Warning System
EIA	Electronics Industry Association
EICAS	Engine Indicating and Crew Alerting System
ETA	Estimated Time of Arrival
ETE	Estimated Time Enroute
ETT	EFIS Training Tool
FA	Course from a Fix to Altitude
FAA	Federal Aviation Administration
FAF	Final Approach Fix
FAR	Federal Aviation Regulation
FAWP	Final Approach Waypoint (same as FAF)
FD	Course from a Fix to DME Distance
FDE	Fault Detection and Exclusion
FHA	Functional Hazard Analysis
FIFO	"First in, First out"
FIS	Flight Information Service
FIS-B	Flight Information Service-Broadcast
FL	Flight Level
FLTA	Forward Looking Terrain Awareness
FMEA	Fault Mode and Effects Analysis

FMS	Flight Management System
FPE	Floating Point Emulation
FPM	Feet per Minute
FPM	Flight Path Marker
FSD	Full Scale Deflection
FTE	Flight Technical Error
FTP	Fictitious Threshold Point
GAGAN	India's GPS and GEO-Augmented navigation Navigation System
GBAS	Australia's Ground Based Augmentation System
GLONASS	Russian Global Navigation Satellite System
GLS	GNSS Landing System
GMF	Ground Maintenance Function
GND	Ground (potential)
GNSS	Global Navigation Satellite System
GPH	Gallons per Per Hour
GPI	Glidepath Intercept
GPIP	Glide Path Intercept Point
GPS	Global Positioning System
GPWS	Ground Proximity Warning System
HAL	Horizontal Alert Limit
HAT	Height Above Threshold
HFOM	Horizontal Figure of Merit
hPa	Hectopascal
HPL	Horizontal Protection Level
HSI	Horizontal Situation Indicator
HUD	Head Up Display

HUL	Horizontal Uncertainty Limit
IAP	Instrument Approach Procedure, also; Initial Approach Point
IAS	Indicated Airspeed
IAWP	Initial Approach Waypoint (same as IAP)
IC	Integrated Circuit
ICAO	International Civil Aviation Organization
ICD	Interface Control Document
ID	Identity or Identification
IDS	Integrated Display System (AW-109SP)
IDU	Integrated Display Unit
IFR	Instrument Flight Rules
ILS	Instrument Landing System
IM	Inner Marker
IO	Input/Output
IPV	Instrument Procedure with Vertical Guidance
ISR	Interrupt Service Routine
IVSI	Instantaneous Vertical Speed Indicator
JAD	Jeppesen Aviation Database
JTAG	Joint Test Action Group (IEEE 1149.1 Standard)
K	Kilo=1000
KB	Kilobyte
KIAS	Knots Indicated Airspeed
KT	Knot - Nautical Mile per Hour
KTAS	Knots True Airspeed
LDA	Localizer-type Directional Aid
LED	Light Emitting Diode

LNAV	Lateral Navigation
LOC	Localizer
LOI	Loss of Integrity
LON	Loss of Navigation
LP	Localizer Performance
LPV	Localizer Performance with Vertical Guidance
LRU	Line Replaceable Unit
LSB	Least Significant Bit or Byte
LTP	Landing Threshold Point
MAHP	Missed Approach Holding Point
MAHWP	Missed Approach Holding Waypoint (same as MAHP)
MAP	Missed Approach Point; Missed Approach Procedure
MASPS	Minimum Aviation System Performance Standard
MAWP	Missed Approach Waypoint (same as MAP)
MB	Megabyte
MDA	Minimum Descent Altitude
MEMS	Micro Electro Mechanical System
MFD	Multifunction Display (an IDU with software for showing multiple display screens)
MM	Middle Marker
MOPS	Minimum Operational Performance Standard
MOT	Mark On Target
MSAS	Japan's MTSAT-based Satellite Augmentation System
MSB	Most Significant Bit or Byte
MSL	Mean Sea Level
MSU	Magnetic Sensor Unit
MTBF	Mean Time Between Failures

NACO	National Aeronautical Charting Office
NAS	U.S. National Airspace System
NASA	National Aeronautics and Space Administration
ND	Navigation Display
NDB	Nondirectional Beacon
NED	National Elevation Dataset
NI	Navigational Information
NIMA	National Imagery and Mapping Agency
NM	Nautical Mile
NPA	Non-Precision Approach
OASIS	Open Architecture Systems Integration Symbology
OAT	Outside Air Temperature
OBS	Omnibearing Selector
ODP	Obstacle Departure Procedure
OM	Outer Marker
OT	Other Traffic (Traffic Function)
PA	Proximate Advisory (Traffic Function)
PDA	Premature Descent Alert
PDR	Preliminary Design Review
PFD	Primary Flight Display (display screen showing primary instrumentation -- can also refer to the primary IDU with software that only shows primary instrumentation)
PFDE	Predictive Fault Detection and Exclusion
PFI	Primary Flight Information
PIC	Peripheral Interface Controller
PLI	Pitch Limit Indicator
PM	Personality Module

PN	Part Number
PRAIM	Predictive Receiver Autonomous Integrity Monitoring
PSAC	Plan for Software Aspects of Certification
PSCP	Project Specific Certification Plan
PSP	Partnership for Safety Plan
PTN	Problem Tracking Number
QA	Quality Assurance
QFE	Altimeter setting provides height above reference point
QM	Quality Management
QNE	Altimeter setting provides pressure altitude readout
QNH	Altimeter setting provides MSL altitude at a reporting point
RA	Resolution Advisory (Traffic Function)
RAIM	Receiver Autonomous Integrity Monitoring
RAM	Random Access Memory
RBP	Remote Bug Panel
RCP	Radar Control Panel
RHT	Radar Height
RMI	Radio Magnetic Indicator
RNAV	Area Navigation
RNP	Required Navigation Performance
RS	EIA Recommended Standard
RTC	Real Time Computing
RTCA	Radio Telephone Commission for Aeronautics
RTD	Resistive Thermal Detector
RTL	Run Time Library
Rx	Receive

SA	Selective Availability
SAE	Society of Automotive Engineers
SAS	Software Accomplishment Summary
SBAS	Satellite Based Augmentation System
SCI	Software Configuration Index
SCMP	Software Configuration Management Plan
SCR	Software Conformity Review
SCS	Software Coding Standards
SDCM	System of Differential Correction and Monitoring
SDD	Software Design Document
SDP	Software Development Plan
SDS	Software Design Standards
SECI	Software Environment Configuration Index
SIGMET	Significant Meteorological Advisory
SMA	Sub-Miniature version A connector
SN	Serial Number
SNI	Serial Number Information
SOI	Stage of Involvement (FAA software audit)
SPR	Software Problem Report
SQA	Software Quality Assurance
SQAP	Software Quality Assurance Plan
SQAR	Software Quality Assurance Representative
SRD	Software Requirements Document
SRS	Software Requirements Standards
SRTM	Shuttle Radar Topographical Mission
SSA	System Safety Assessment

SSM	Sign Status Matrix
STAR	Standard Terminal Arrival Routes
STC	Supplemental Type Certificate
STP	Software Test Protocol
STS	Software Test Specification
SUA	Special Use Airspace
SV	Service Vehicle
SVCP	Software Verification Cases and Procedures
SVP	Software Verification Plan
SVR	Software Verification Results
SVS	Synthetic Vision System
SYRD	System Requirements Document
TA	Traffic Advisory (Traffic Function)
TACAN	Ultra-High Frequency Tactical Air Navigational Aid
TAFs	Terminal Aerodrome Forecasts
TAS	Traffic Advisory System
TAS	True Airspeed
TAWS	Terrain Awareness and Warning System
TCAD	Traffic Collision Alert Device
TCAS	Traffic Collision Alert System
TCH	Threshold Crossing Height
TD	Traffic Display
TERPS	Terminal Instrument Procedures
TFR	Temporary Flight Restriction
TIS	Traffic Information Service
TIS-B	Traffic information Service-Broadcast

TMS	Texas Instruments family of DSP processors
TQP	Tool Qualification Plan
TSO	Technical Standard Order
TTA	Time to Alert
Tx	Transmit
UART	Universal Asynchronous Receiver-Transmitter
UIM	User Interface Module
USGS	United States Geological Survey
UTC	Universal Time Coordinated
VA	Heading to Altitude
VAL	Vertical Alert Limit
VD	Heading to DME Distance
VFOM	Vertical Figure of Merit
VFR	Visual Flight Rules
VHF	Very High Frequency
VNAV	Vertical Navigation
VOR	VHF Omnidirectional Radio
VORTAC	Collocated VOR and TACAN
VPL	Vertical Protection Level
VR	Heading to Radial Termination
VSI	Vertical Speed Indicator
VTF	Vectors to Final
VUL	Vertical Uncertainty Limit
WAAS	Wide Area Augmentation System
WGS84	World Geodetic System 1984

2.2. System Overview

The IDU-450 EFIS System is a complete flight and navigation instrumentation system that intuitively provides information to the pilot via computer generated screen displays. The screen displays include three-dimensional, enhanced situational awareness Primary Flight Displays (PFD) and Multi-Function Displays (MFD). The Multi-Function Display may be configured to show a moving map, an HSI, terrain, traffic, datalink weather, radar, or video.

At any given time, each system only has one IDU transmit enabled to send RS-232 and RS-422 system transmissions. By default the PFD is “Transmit Enabled” and, if it subsequently fails, the respective MFD becomes transmit enabled.

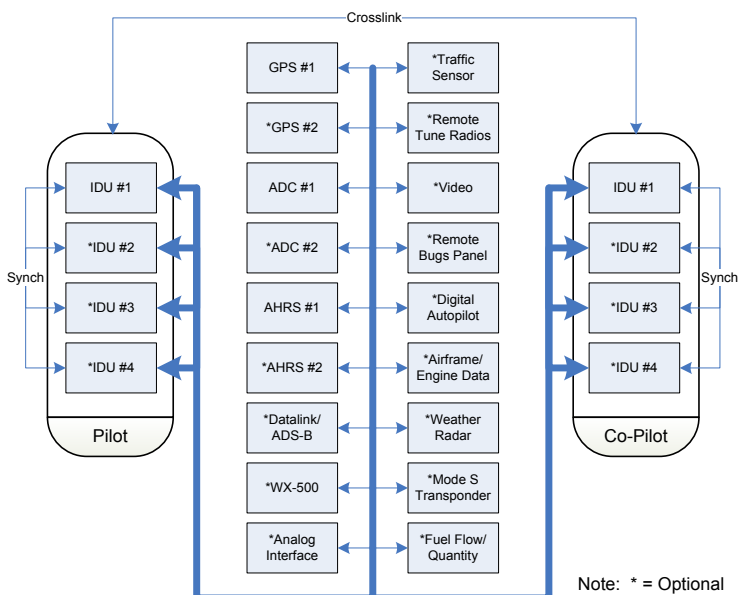


Figure 2-1: System Diagram

2.2.1. IDU Initialization

The hardware, including file system, IO, and graphics, are initialized. Immediately after graphics initialization, a logo screen with the text “INITIALIZING” is displayed and includes the Genesys Aerosystems logo, software version number, and software part number. The

software version number delineates: (1) major revision number (i.e., “8.0”) and (2) minor revision letter (i.e., “D”). The software version number and software part number display as follows.

Table 2-1: IDU Initialization Software Version and Part Numbers

Version Number	Part Number
Rev 8.0D	25-EFIS80D-SW-0002

Aircraft configurations are initially read from flash drive storage. This provides the IDUs with a default configuration setup in the event of personality module failure. The Pilot System #0 or #1 IDU reads aircraft configuration from its personality module and, in the case of a multi-screen installation with a #1 IDU, transmits this configuration to the other IDUs, including all Co-Pilot System IDUs. Upon reception of the configurations transmission from the Pilot System #0 or #1 IDU, the other IDUs save the transmitted configurations to flash drive storage.

Aircraft parameters (latitude, longitude, altitude), as they existed prior to the last system shutdown, are read to initialize the system, which allows for a good initialization, even if system sensors are failed or not yet initialized. For a future application update (i.e., updating software version 8.0D to 8.0X), all aircraft settings re-initialize to default values. Otherwise, aircraft settings, as they existed prior to the last system shutdown, are used to initialize the system with the exception of the following default values:

- 1) Active flight plan structure and associated values are cleared.
- 2) Timers are turned off.
- 3) Minimum altitude setting is turned off.
- 4) FMS OBS setting is set to automatic.
- 5) VOR/LOC 1 OBS setting is set to 360°.
- 6) VOR/LOC 2 OBS setting is set to 360°.
- 7) Parallel offset is set to 0 NM.
- 8) Airspeed bug is turned off.
- 9) Target altitude bug is turned off.

- 10) Vertical speed bug is turned off.
- 11) HSI navigation source is set to FMS.
- 12) Heading bug is set to 360° (HeliSAS-E) or turned off.
- 13) Datalink and map panning modes are set to off.
- 14) PFD zoom mode is set to off.
- 15) Manual RNP is set to off.
- 16) PFD skyway is set to on.
- 17) RDR-2000/2100 scale is initialized to 80NM.
- 18) Crosslink is initialized to on.

Based upon the air/ground mode parameter value from the last system shutdown, the IDU decides whether it is booting on the ground or in flight.

If booting on the ground, the following actions happen:

- 1) A logo screen with the words “TESTING” is displayed for a number of seconds while the various hardware subsystems are initialized.
- 2) CRC-32 values for application executable, limitations files, NavData files, obstruction files, and terrain header files are checked within 1.5 to 3 minutes.
- 3) If the CRC-32 check fails, the program exits with an error message and creates a bit result file indicating failure. This results in the system rebooting, and the IDU is inoperable until the anomaly is resolved.
- 4) If the CRC-32 check passes, the program continues to initialize and creates a bit result file indicating passage.
- 5) If the “Baro Auto-Setting on Startup Flag” is enabled, the application auto-sets the altimeter based upon the terrain elevation at the startup point.
- 6) A logo screen displaying database versions and validity dates displays the message “**PRESS ANY KEY TO CONTINUE.**”
 - a) Software CRC-32;

- b) Aircraft Type;
 - c) Database Versions and Validity Dates
- 7) If all critical sensors (GPS, ADC, and AHRS) are in normal condition, the display screens are shown immediately. The #1 IDU initializes to the PFD screen.
- 8) If any critical sensor is not in normal condition, a logo screen with a two-minute countdown timer is shown.
- 9) The display screen is shown at the earliest of:
- a) When two minutes have elapsed;
 - b) When the pilot presses any button to escape the startup countdown;
 - c) When all critical sensors are in normal condition, the #1 IDU initializes to the PFD screen;
 - d) Other IDUs: IDU #2 initializes to the MFD screen. All other IDUs initialize to the MFD screen;
 - e) On the IDU#0 or #2 with fuel totalizer functions enabled, the fuel set menu activates to remind the pilot to set the fuel totalizer quantity. N/A for AW-109SP aircraft due to fuel quantity from the IDS.

If booting in the air, the following actions happen:

- 1) A logo screen with the words “**QUICK START**” is displayed.
- 2) The bit result file created during the last ground boot is checked. If the bit result file indicates a failure, the program exits with an error message. If the bit result file indicates passage, the program continues.
- 3) The display screens initialize immediately.
- 4) The display screens initialize as follows:
 - a) IDU #1: PFD
 - b) Other IDUs: IDU #2 initializes to display of LPV Enable and AFCS SW Part Number (AW-109SP)

The status of the LPV Enable factory limits setting is displayed on the database version and validity screen.

```

REV 8.0D
P/N: 25-EFIS800-SU-0002
SOFTWARE OK (CPU NUMBER 1)
SOFTWARE CRC = 0X3B372426
AIRCRAFT TYPE GENERIC
NAVIGATION DATA: COVERAGE = WORLD (CYCLE1601)
VALID DATE 01-02-2016
EXPIRE DATE 02-04-2016
OBSTRUCTION DATA: DATE 02-04-2016
TERRAIN DATA: COVERAGE = S75W180 - N75E181
VALID DATE 05-26-2007
PRESS ANY KEY TO CONTINUE

```

Other Rotorcraft

```

REV 8.0D
P/N: 25-EFIS800-SU-0002
SOFTWARE OK (CPU NUMBER 1)
SOFTWARE CRC = 0X3B372426
GPS/SBAS LPU MODE ENABLED
AIRCRAFT TYPE AW109SP
NAVIGATION DATA: COVERAGE = WORLD (CYCLE1601)
VALID DATE 01-02-2016
EXPIRE DATE 02-04-2016
OBSTRUCTION DATA: DATE 02-04-2016
TERRAIN DATA: COVERAGE = S75W180 - N75E181
VALID DATE 05-26-2007
PRESS ANY KEY TO CONTINUE

```

Display of LPV Enable and
AFCS SW Part Number
(AW-109SP)

Figure 2-2: Initialization Screen

When connected to an AFCS, which sends software part number data, the AFCS software part number is displayed below the “Aircraft Type” line.

2.3. General Arrangement

The IDU-450 is 6.375” W x 5.65” H x 4.75” D and weighs less than 7.5 lbs. The IDU-450 has the capacity to accommodate integrated peripherals mechanically attached to the CPU but have electrical isolation and redundancy. These modules may include:

- 1) Integrated ADAHRS Sensor Module
- 2) Integrated GPS/SBAS Sensor Module
- 3) Serial Protocol Converters
- 4) Video Format Converters

Data storage consists of two compact flash cards sufficiently sized to hold world terrain, navigational, and obstruction databases.

Because the receive ports of the IDU-450 are connected to the digital sensor modules in parallel, each IDU-450 is independent from all other IDU-450s. In an IFR installation, the software of the primary IDU-450 is configured so only the primary screen Primary Flight Display (PFD) display is as in Figure 2-3.



Figure 2-3: Primary IDU-450 PFD

2.3.1. GPS Aiding Limitation

To prevent gyro drift in the roll attitude solution, continuous corrections to roll attitude are made based upon speed, accelerations, and rates. The preferred correction speed source is airspeed from the Air Data Computer. However, airspeed data becomes noisy and inaccurate as the aircraft slows, and the system automatically transitions to GPS groundspeed (at approximately 55 KIAS) under these conditions.

When flying in a GPS-denied environment, the aircrew should be aware that flight below 55 KIAS could result in a degraded roll attitude solution. Therefore, avoid IMC conditions and crosscheck other attitude instruments when flying below 55 KIAS and transition to flight above 55 KIAS as soon as practicable.

NOTE:

Not applicable for AW-109SP or other rotorcraft with other AHRS than Genesys ADAHRS installed.

2.4. Color Conventions

The Genesys Aerosystems EFIS uses a consistent set of colors for displaying information detailed as follows. (Any color representation may not be exactly identical as it appears on the IDU.)



WHITE is used for scales, associated labels and figures, pilot action, or data entry. Examples:

- Scales markings (airspeed, altitude, heading, VSI, pitch, map ranges, etc.)
- Pilot-selected values (airspeed, heading, altitude)
- Secondary flight data (TAS, wind, OAT, timers, etc.)



CYAN is used for IFR navigation dataset items (airports with instrument approach procedures, VORs, intersections, and Advisory text on black background).



MAGENTA is used to indicate certain navigation database items and electronically calculated or derived data. Examples:

- Active waypoint related symbols
- Course data (desired track, CDI)
- VFR airports, NDBs
- VNAV altitudes



GRAY is used for conformal runway depiction (light gray for usable portion of the active runway, dark gray for other runway surfaces) and as a figure background for airspeed and altitude readout.



GREEN is used to indicate normal or valid operation (airspeed, altitude tape coloring, status indication, etc.). Examples:

- Aircraft ground track
- Skyway symbology
- Airspeeds in green arc
- Autopilot annunciations



DARK GREEN is used for the terrain indication on the moving map. The slope between adjacent terrain pixels in an increasing longitude direction determines the shade used.



AMBER (YELLOW) is used to identify conditions requiring immediate pilot awareness and perhaps subsequent pilot action. Examples:

- Caution indications
- Altitude or heading alert
- Component failure indication
- Minimum altitude
- Airspeeds in amber (yellow) arc



OLIVE is used in various shades to show terrain at or below aircraft altitude.



BROWN Terrain is colored shades of brown when above the aircraft altitude. The slope between adjacent terrain pixels in an increasing longitude direction determines the shade used. Shades of brown are used when terrain is at or above the aircraft altitude on the MFD.



BLUE is used in a variety of shades to indicate the sky portion of the PFD. Deep blue denotes areas of water and takes precedence over other colors or when terrain is displayed on the PFD and on the moving map.



RED is used to indicate aircraft limitations or conditions which require immediate pilot action. Examples:

- Warnings (airframe operation limits, terrain awareness)
- Pitch limit indicator (low speed awareness)
- Airspeeds in red arc



BLACK is used for the field of view angle lines on the moving map, for figures on a gray background, and for outlining borders and certain figures/elements on backgrounds where contrast is minimal, e.g., airspeed, altitude, and menu tiles on the PFD/MFD.

2.5. Warning/Caution/Advisory System

The IDU's integrated audio/visual warning system monitors a wide variety of parameters and provides annunciations for conditions demanding pilot awareness. There are three categories of annunciations: warnings, cautions, and advisories. Where a time delay is referenced, it is the programmed delay in seconds prior to the annunciation appearing. The following table lists the annunciations provided by the IDU:

WARNING

Displayed with red flag and an aural annunciation that repeats until the condition goes away or is acknowledged by the pilot.

CAUTION

Displayed with amber (yellow) flag and a single aural annunciation.

ADVISORY

Displayed with black flag and blue letters with a single aural annunciation.

Table 2-2: Warnings, Cautions, and Advisories

Display Flag "--" indicates no flag	Aural Annunciation	Condition
GLIDESLOPE	"Glideslope, Glideslope"	Within GPWS Mode 5 warning envelope. Half second time delay.

Table 2-2: Warnings, Cautions, and Advisories





Display Flag "--" indicates no flag	Aural Annunciation	Condition
	"Fuel Low, Fuel Low"	One of the following conditions is true: <ol style="list-style-type: none"> 1) One of the Low Fuel Warning discrete inputs is active 2) One of the sensed fuel tank quantities is below its low fuel warning threshold 3) Total aircraft fuel is below the pilot-set emergency fuel threshold. 4) Not applicable for AW-109SP. 1-minute time delay.
	"Warning Obstruction, Warning Obstruction"	Obstruction within TAWS FLTA warning envelope. Half second time delay.
	"Pull Up, Pull Up"	Within GPWS Mode 1 warning envelope. Half second time delay.
	"Terrain, Terrain, Pull Up, Pull Up"	Within GPWS Mode 2 warning envelope. Half second time delay.
	"Warning Terrain, Warning Terrain"	Terrain cell within TAWS FLTA warning envelope. Half second time delay.

Table 2-2: Warnings, Cautions, and Advisories

Display Flag "--" indicates no flag	Aural Annunciation	Condition
TRAFFIC	"Traffic, Traffic"	Resolution Advisory. Not given if own aircraft below 400' AGL nor if target is below 200' AGL (ground target). Audio not generated with TCAS-II system. No time delay.
CAUTIONS		
ADC1 FAIL	Alert Tone	Only active in dual-ADC installation. Indicates no valid indicated airspeed, pressure altitude, or VSI received from ADC #1 for more than 1 second. No time delay.
ADC2 FAIL	Alert Tone	Only active in dual-ADC installation. Indicates no valid indicated airspeed, pressure altitude, or VSI received from ADC #2 for more than 1 second. No time delay.
ADS-B FAIL	Alert Tone	Enabled by ADS-B Out Fail Warning Limits setting. Mode-S Transponder indicates bad ADS-B Out Status. 2-second time delay.
AHRS1 FAIL	Alert Tone	Only active in dual-AHRS installation. Indicates no valid bank, pitch, or heading received from AHRS #1 for more than 1 second. No time delay.

Table 2-2: Warnings, Cautions, and Advisories

Display Flag "--" indicates no flag	Aural Annunciation	Condition
AHRS2 FAIL	Alert Tone	Only active in dual-AHRS installation. Indicates no valid bank, pitch, or heading received from AHRS #2 for more than 1 second. No time delay.
ALT MISCOMP	Alert Tone	Only active in dual-ADC installation with neither ADC in failure condition. Indicates pressure altitude difference between ADCs is beyond limits. 10-second time delay. Inhibit for 5 minutes after startup.
ATT MISCOMP	Alert Tone	Only active in dual-AHRS installation with neither AHRS in failure condition. Indicates pitch or roll difference between AHRS is beyond limits (6°). 10-second time delay. Inhibit for 5 minutes after startup.

Table 2-2: Warnings, Cautions, and Advisories

Display Flag "--" indicates no flag	Aural Annunciation	Condition
AUX SENSOR	"Auxiliary Sensor Failure, Auxiliary Sensor Failure"	No valid message or bad status received from installed optional sensors. Sensor status displayed in FAULTS menu. Applies to the following optional sensors: <ol style="list-style-type: none"> 1) RS-232 TAS System 2) ADS-B System 3) WSI Datalink System 4) WX-500 Lightning System 5) Analog Interface System 6) Weather Radar 7) Weather Radar Control Panel 5-second time delay.
CHECK GEAR	"Check Gear, Check Gear"	Activated if RG flag is set to 1, aircraft is below 150' AGL, aircraft is descending, and any landing gear is not down. 2-second time delay. Not applicable for AW-109SP.

Table 2-2: Warnings, Cautions, and Advisories

Display Flag "--" indicates no flag	Aural Annunciation	Condition
CHECK IDU 1 CHECK IDU 2 CHECK IDU 3 CHECK IDU 4	Alert Tone	When armed (i.e., at least one intra-system monitor message has been received from the transmitting display), checks intra-system monitor messages. Indicates either: <ol style="list-style-type: none"> 1) screen counter value has not changed in the last 1 second \pm 0.1 seconds; or 2) intra-system monitor message is not fresh (i.e., no message received for longer than 1 second \pm 0.1 second). "#" indicates which IDU is failing the check, either IDU 1, IDU 2, IDU 3, or IDU 4. No time delay.

Table 2-2: Warnings, Cautions, and Advisories

Display Flag "--" indicates no flag	Aural Annunciation	Condition
CHECK RANGE	"Check Range, Check Range"	<p>Less than 30 minutes buffer (at current groundspeed) between calculated range and distance to:</p> <ol style="list-style-type: none"> 1) The last waypoint if it is active; or 2) The airport if on a missed approach; or 3) Along-route distance to destination. <p>Not activated in climbing flight. Not activated if below 60 knots groundspeed.</p> <p>5-minute time delay.</p>
COOLING FAN	Alert Tone	<p>Triggered when external cooling fan is commanded on by the cooling fan discrete output, and the cooling fan status discrete input indicates the cooling fan is not rotating.</p> <p>1-minute time delay.</p>

Table 2-2: Warnings, Cautions, and Advisories

Display Flag "--" indicates no flag	Aural Annunciation	Condition
FUEL SPLIT	Alert Tone	Compares the volume of fuel designated left wing tank fuel vs. volume of fuel designated right wing tank fuel to the Fuel Split Caution Threshold. Issues a caution if the difference exceeds the Fuel Split Caution Threshold. Only performed if the Fuel Split Caution Threshold is non-zero and both left and right wing tank fuel are monitored and valid. 1-minute time delay.
GLIDESLOPE	"Glideslope, Glideslope"	Within GPWS Mode 5 caution envelope. Half second time delay.
GPS LOI	Alert Tone	GPS/SBAS loss of integrity caution. No time delay.
GPS LON	Alert Tone	GPS/SBAS loss of navigation caution. No time delay.

Table 2-2: Warnings, Cautions, and Advisories

Display Flag "--" indicates no flag	Aural Annunciation	Condition
<p>GPS MISCMP</p>	<p>Alert Tone</p>	<p>Only active in dual-GPS/SBAS installation with neither GPS/SBAS in failure condition. Indicates position, track, or groundspeed difference between GPS/SBAS units is beyond limits as follows:</p> <p>Position: Enroute Mode 4NM Terminal Mode 2NM Departure Mode .6NM IFR Approach Mode .6NM VFR Approach Mode .6NM</p> <p>Track: If groundspeed is greater than 30 kts, miscompare if difference is more than 4°.</p> <p>Groundspeed: If difference between GPS#1 and GPS#2 miscompare is more than 10 kts.</p> <p>10-second time delay.</p>
<p>GPS1 FAIL</p>	<p>Alert Tone</p>	<p>Only active in dual-GPS/SBAS installation. Indicates no valid message received from GPS/SBAS #1 for more than 5 seconds. No time delay.</p>

Table 2-2: Warnings, Cautions, and Advisories

Display Flag "--" indicates no flag	Aural Annunciation	Condition
GPS2 FAIL	Alert Tone	Only active in dual-GPS/SBAS installation. Indicates no valid message received from GPS/SBAS #2 for more than 5 seconds. No time delay.
GS MISCOMP	Alert Tone	Only active when two valid glideslopes are being received. Indicates at least one glideslope is receiving a signal within 1 dot of center and difference between glideslope signals is beyond limits (0.25 Dots). 10-second time delay.
HDG MISCOMP	Alert Tone	Only active in dual-AHRS installation with neither AHRS in failure condition. Indicates heading difference between AHRS is beyond limits (6°). (AW-109SP set to 6°). 10 second time delay otherwise 60 second time delay. Inhibit for 5 minutes after startup.
HRZ SYNC	None	Allows re-centering of the horizon during CAT-A departures. AW-109SP only.

Table 2-2: Warnings, Cautions, and Advisories

Display Flag "--" indicates no flag	Aural Annunciation	Condition
IAS MISCOMP	Alert Tone	<p>Only active in dual-ADC installation with neither ADC in failure condition. Indicates indicated airspeed difference between ADCs is beyond limits.</p> <p>10-second time delay.</p> <p>Inhibit for 5 minutes after startup.</p>
LOC MISCOMP	Alert Tone	<p>Only active when two valid localizers are being received. Indicates at least one localizer is receiving a signal within 1 dot of center and difference between localizer signals is beyond limits (0.25 Dots).</p> <p>10-second time delay.</p>

Table 2-2: Warnings, Cautions, and Advisories




Display Flag "--" indicates no flag	Aural Annunciation	Condition
	"Fuel Low, Fuel Low"	A Low Fuel Warning is not active, and one of the following conditions is true: <ol style="list-style-type: none"> 1) One of the Low Fuel Caution discrete inputs is active. 2) One of the sensed fuel tank quantities is below its low fuel caution threshold. 3) Total aircraft fuel is below the pilot-set minimum fuel threshold. 4) Not applicable for AW-109SP. 1-minute time delay.
	Alert Tone	No valid heading received from selected AHRS for more than 1 second. No time delay. Disabled if in MFD-only operation. Not shown if PFD heading scale is red-X'd.
	Alert Tone	No valid position data available from selected GPS/SBAS for more than 5 seconds and Dead Reckoning not available. No time delay.

Table 2-2: Warnings, Cautions, and Advisories

Display Flag "--" indicates no flag	Aural Annunciation	Condition
NO TAWS	Alert Tone	Indicates aircraft is currently beyond extent of terrain database or a failure condition exists preventing the TAWS FLTA function from operating. Half second time delay.
OAT SENSOR OAT1 SENSOR OAT2 SENSOR	Alert Tone	Indicates OAT sensor has failed. "OAT SENSOR" applicable to single ADC installation. "OAT# SENSOR" applicable to dual ADC installation. Indicates OAT indication is invalid, but other air data parameters are normal (i.e., air data is not red-X'd). Half second time delay.
OBSTRUCTION	"Caution Obstruction, Caution Obstruction"	Obstruction within TAWS FLTA caution envelope. Half second time delay.
PLT MISCOMP CPLT MISCOMP	Alert Tone	Only active when fresh intra-system monitor messages are being received. Indicates a critical parameter being used by another display exceeds the miscompare thresholds when compared to the monitoring display. Compares the following critical parameters:

Table 2-2: Warnings, Cautions, and Advisories

Display Flag "--" indicates no flag	Aural Annunciation	Condition
		1) Attitude (Pitch and Roll) (use Attitude Miscompare logic) 2) Heading (use Heading Miscompare logic) 3) Pressure Altitude (use Altitude Miscompare logic) 4) Indicated Airspeed (use Airspeed Miscompare logic) 5) Localizer (both inputs) (use Localizer Miscompare logic) 6) Glideslope (both inputs) (use Glideslope Miscompare logic) 7) Radar Altitude (use Radar Altitude Miscompare logic) 8) Latitude (Use GPS/SBAS Miscompare logic) 9) Longitude (Use GPS/SBAS Miscompare logic) 10) Track (Use GPS/SBAS Miscompare logic)

Table 2-2: Warnings, Cautions, and Advisories

Display Flag "--" indicates no flag	Aural Annunciation	Condition
		11) Groundspeed (Use GPS/SBAS Mis-compare logic) 1-second time delay.
PLT1 OVRTMP PLT2 OVRTMP PLT3 OVRTMP PLT4 OVRTMP CPLT1 OVRTMP CPLT2 OVRTMP CPLT3 OVRTMP CPLT4 OVRTMP	Alert Tone	IDU core temperature greater than 95°C. 2-second time delay.
PLT1 SCC PLT2 SCC PLT3 SCC PLT4 SCC CPLT1 SCC CPLT2 SCC CPLT3 SCC CPLT4 SCC	Alert Tone	Indicates SCC card (Personality Module) could not be read upon power-up. This means limits internal to the IDU are being used by the system. Only active on the ground.
RADALT FAIL	Caution	Only active in single-Radar Altimeter installation. For analog radar altimeter, indicates below 2000'AGL in Air Mode without a valid radar altimeter reading. 2-second time delay.
RADALT1 FAIL	Alert Tone	Only active in dual-Radar Altimeter installation. Indicates no radar altimeter reading received from Radar Altimeter #1 for more than 1 second. Annunciation is also displayed in Ground Mode. 2-second time delay.

Table 2-2: Warnings, Cautions, and Advisories

Display Flag "--" indicates no flag	Aural Annunciation	Condition
RADALT2 FAIL	Alert Tone	Only active in dual-Radar Altimeter installation. Indicates no radar altimeter reading received from Radar Altimeter #2 for more than 1 second. Annunciation is also displayed in Ground Mode. 2-second time delay.
RALT MISCOMP	Alert Tone	Only active in dual-radar altimeter installation with neither radar altimeter in failure condition. Indicates radar altitude difference between radar altimeters is beyond limits as follows. $\geq 500' \text{AGL} \quad \Delta 14\%$ $100 - 500' \text{AGL} \quad \Delta 10\%$ $< 100' \text{AGL} \quad \Delta 10'$ 10-second time delay.
SAME ADC	Alert Tone	Only active in dual-system (pilot and co-pilot), dual-ADC installation with good inter-system communications, and neither ADC in failure condition. Indicates both systems are operating from same ADC source. No time delay.

Table 2-2: Warnings, Cautions, and Advisories

Display Flag "--" indicates no flag	Aural Annunciation	Condition
SAME AHRS	Alert Tone	Only active in dual-system (pilot and co-pilot), dual-AHRS installation with good inter-system communications, and neither AHRS in failure condition. Indicates both systems are operating from same AHRS source. No time delay.
SAME GPS	Alert Tone	Only active in dual-system (pilot and co-pilot), dual-GPS/SBAS installation with good inter-system communications, and neither GPS/SBAS in failure condition. Indicates both systems are operating from same GPS/SBAS source. No time delay.
SAME NAV	Alert Tone	Only active in dual-system (pilot and co-pilot) with good inter-system communications. Indicates both systems are operating from same navigation source. Alert inhibited if both systems are operating from GPS/SBAS in a single-GPS/SBAS installation. No time delay.

Table 2-2: Warnings, Cautions, and Advisories

Display Flag "--" indicates no flag	Aural Annunciation	Condition
SAME RADALT	Alert Tone	Only active dual-system (pilot and co-pilot), dual-radar altimeter installation with good inter-system communications, and neither radar altimeter in failure condition. Indicates both systems are operating from same radar altimeter source. No time delay.
SINK RATE	"Sink Rate, Sink Rate"	Within GPWS Mode 1 caution envelope. Half second time delay.
TAWS AUTOROT	Alert Tone	TAWS autorotation mode activated through use of discrete input. No time delay.
TCAS FAIL	Alert Tone	Only active with ARINC735A-1 TCAS-II, TCAS-I, or TAS system. Indicates lack of communications with system or failure indication from system. No time delay.
TERRAIN	"Caution Terrain, Caution Terrain"	Terrain cell within TAWS FLTA caution envelope. Half second time delay.
		Within GPWS Mode 2 caution envelope. Half second time delay.

Table 2-2: Warnings, Cautions, and Advisories

Display Flag "--" indicates no flag	Aural Annunciation	Condition
<p>TOO LOW</p>	<p>“Too Low Terrain, Too Low Terrain”</p>	<p>Within GPWS Mode 3 envelope. Half second time delay.</p>
	<p>“Too Low Gear, Too Low Gear”</p>	<p>Within GPWS Mode 4 “Too Low Terrain” envelope. Half second time delay.</p>
	<p>“Too Low Flaps, Too Low Flaps”</p>	<p>Within GPWS Mode 4 “Too Low Gear” envelope. Half second time delay.</p>
	<p>Alert Tone</p>	<p>Within GPWS Mode 4 “Too Low Flaps” envelope. Half second time delay.</p> <p>Compares the volume of sensed fuel to the fuel totalizer calculation. Issues a caution if the difference exceeds the Totalizer Mismatch Caution Threshold. Only performed if:</p> <ol style="list-style-type: none"> 1) Totalizer Mismatch Caution Threshold is non-zero; 2) Fuel totalizer is enabled; 3) Unmonitored Fuel Flag is false; 4) Fuel totalizer has a valid value; and 5) Fuel levels are valid. <p>1-minute time delay.</p>
<p>TOTALZR QTY</p>		

Table 2-2: Warnings, Cautions, and Advisories

Display Flag "--" indicates no flag	Aural Annunciation	Condition
TRAFFIC	"Traffic, Traffic"	Traffic Advisory. Not given if own aircraft below 400' AGL nor if target is below 200'AGL (ground target). Audio not generated with TCAS-II system. No time delay.
VERT LON	Alert Tone	Loss of vertical navigation caution. No time delay.
XFILL FAIL	Alert Tone	Only active in dual-system (pilot and co-pilot). Indicates lack of inter-system communications. 2-second time delay. Inhibit for 30 seconds after startup.
--	"Altitude, Altitude"	Deviation greater than 150' from selected altitude after capture. Altitude capture defined as being within 100' of altitude. 2-second time delay. If not on a descending VNAV profile, deviation greater than 150' from altitude of the current or prior VNAV waypoint after capture. Altitude capture defined as being within 100' of altitude. 2-second time delay.

Table 2-2: Warnings, Cautions, and Advisories

Display Flag "--" indicates no flag	Aural Annunciation	Condition
--	"Decision Height"	Deviation from above to below decision height bug. Causes decision height readout to turn amber (yellow) and flash. No time delay. Not applicable for AW-109SP.
--	"Minimums, Minimums"	Deviation from above to below minimum altitude bug. Minimum altitude readout turns amber (yellow) and flashes. No time delay.
ADVISORIES		
ADC INIT	Chime	ADC not at full accuracy during warm-up. No time delay.
ADC1 ANNUN	Chime	For AW-109SP when single EFIS system, dual ADC and ADC1 are selected, and ADC1 is valid.
ADC2 ANNUN	Chime	For AW-109SP when single EFIS system, dual ADC and ADC2 are selected, and ADC2 is valid.
AHRS DG	Chime	Activated DG mode if available.
AHRS1 ANNUN	Chime	For AW-109SP when single EFIS system, dual AHRS and AHRS1 are selected, and AHRS1 is valid.

Table 2-2: Warnings, Cautions, and Advisories






Display Flag "--" indicates no flag	Aural Annunciation	Condition
	Chime	For AW-109SP when single EFIS system, dual AHRS and AHRS2 are selected, and AHRS2 is valid.
	Chime	GPS/SBAS Actual Navigation Performance based upon current GPS/SBAS HPL.
	Chime	Only active in dual-system (pilot and co-pilot) installation. Indicates mismatch of altimeter settings or altimeter modes between systems. 10-second time delay.
	Chime	Ascending through transition level: Altimeter not set to 29.92 inHg or 1013 mbar. Descending through transition level: Altimeter set to 29.92 inHg or 1013 mbar. Descent warning times out in 10 seconds. 2-second time delay. Disabled during QFE operation.
	Chime	GPS/SBAS in dead reckoning mode with valid ADC and AHRS data. Timer shows time since loss of position to indicate quality of DR solution. No time delay.

Table 2-2: Warnings, Cautions, and Advisories

Display Flag "--" indicates no flag	Aural Annunciation	Condition
FLTA INHBT	Chime	Shown when the FLTA function is automatically inhibited during normal operation. "NO TAWS" caution and "TAWS INHBT" advisory have priority over this message. No time delay.
FPM INHBT	Chime	Flight Path Marker inhibit function activated through use of momentary discrete input. No time delay.
LNAV APPR	Chime	GPS/SBAS in LNAV Approach Mode. No time delay.
LNU/UNU APPR	Chime	GPS/SBAS in LNAV/VNAV Approach Mode. No time delay.
LP APPR	Chime	GPS/SBAS in LP Approach Mode. No time delay.
LPV APPR	Chime	GPS/SBAS in LPV Approach Mode. No time delay.
PLT1 PWR PLT2 PWR PLT3 PWR PLT4 PWR CPLT1 PWR CPLT2 PWR CPLT3 PWR CPLT4 PWR	Chime	Indicates one of the dual redundant power supplies within an IDU is not functioning correctly. Only active on the ground. 1 minute time delay.

Table 2-2: Warnings, Cautions, and Advisories

Display Flag "--" indicates no flag	Aural Annunciation	Condition
PTK = L 1NM PTK = L 20NM PTK = R 1NM PTK = R 20NM PTK ENDING	Chime	GPS/SBAS Parallel Offset path advisory. ## is nautical miles left (L) or right (R) of main path. No time delay. Text changes to "PTK ENDING" if within the parallel offset distance from a parallel offset exit waypoint. No time delay.
RNP X.XXA RNP XX.XA	Chime	GPS/SBAS Automatic Required Navigation Performance as acquired from navigation database
RNP X.XXM RNP XX.XM	Chime	GPS/SBAS Manual Required Navigation Performance as set by pilot.
SUSPEND	Chime	GPS/SBAS automatic waypoint sequencing is suspended. Caused by being on final approach segment prior to arming missed approach, selecting manual GPS/SBAS OBS, or being in holding prior to activating the CONT tile. No time delay.
SWISS GRID	Chime	When Swiss Grid Mode is active. Only active for AW-109SP.
TA ONLY	Chime	Only active with TCAS-II system. Indicates TCAS-II system is unable to display resolution advisories. No time delay.

Table 2-2: Warnings, Cautions, and Advisories

Display Flag "--" indicates no flag	Aural Annunciation	Condition
TAS INHBT	Chime	TAS aural inhibited through activation of TCAS/TAS Audio Inhibit discrete input. No time delay.
TAWS GS CNX	Chime	TAWS glideslope cancel (GPWS Mode 5) activated through use of discrete input. No time delay. GS Cancel annunciation feature is for Enhanced HTAWS only.
TAWS INHBT	Chime	TAWS inhibited (audio only) through use of discrete input. No time delay.
TAWS LOW ALT	Chime	TAWS low altitude mode activated through use of discrete input. No time delay.
TCAS STBY	Chime	Only active with TCAS-II system. Indicates system is either: (1) in standby or (2) executing functional test in flight. No time delay.
TCAS TEST	Chime	Only active with TCAS-II system. Indicates system is in functional test on ground. No time delay.
TERMINAL	Chime	GPS/SBAS in Terminal mode. No time delay. N/A for AW-109SP when in MOT mode.

Table 2-2: Warnings, Cautions, and Advisories

Display Flag "--" indicates no flag	Aural Annunciation	Condition
TRUE NORTH	Chime	True North mode input discrete is asserted and system is operating in True North mode. No time delay.
VECTORS	Chime	GPS/SBAS in Vectors to Final Approach mode prior to sequencing FAWP. No time delay.
VFR APPR	Chime	GPS/SBAS in VFR approach mode. No time delay.
USI BARO	Chime	For AW-109SP Inertial Vertical Speed is not available and valid from the AHRS.
XFILL ARM	Chime	Only active in dual-system (pilot and co-pilot) with good inter-system communications and crossfill not inhibited. Indicates systems are not synchronized and synchronization function is available. No time delay.
XFILL INHBT	Chime	Only active in dual-system (pilot and co-pilot) with good inter-system communications. Indicates crossfill is manually inhibited through use of discrete input. No time delay.

Table 2-2: Warnings, Cautions, and Advisories

Display Flag "--" indicates no flag	Aural Annunciation	Condition
--	Altitude Alert Tone	Tone given when within the greater of 500' or 50% of VSI from uncaptured selected or VNAV way-point altitude. Inhibited in approach procedures. No time delay.
--	Chime	Sounds chime when countdown timer reaches 00:00:00. No time delay.

The volume of aural annunciations is adjusted according to severity as follows:

WARNING

= Full Volume set into aircraft limits

CAUTION

= 80% of volume set into aircraft limits

ADVISORY

= 60% of volume set into aircraft limits

Press the audio mute switch to mute the active aural annunciation.

Flags are visually prioritized with active warning flags displayed above active caution flags, which are displayed above active advisory flags. Within categories, active flags are stacked in chronological order with the most recent annunciation on top. Warning flags flash at 2Hz until acknowledged by pressing the audio mute switch. Caution flags flash at 1 Hz until acknowledged by pressing the audio mute switch. Only the highest priority (in criticality and recency), unacknowledged aural annunciation is played at any given time. In addition, to further minimize cockpit confusion, the above annunciations are grouped and prioritized so only one annunciation is active. Annunciations prioritized in this manner are as follows (higher in list = higher priority).

Table 2-3: Annunciations Priority	
1)	GPWS Mode 1 Warning
2)	GPWS Mode 2 Warning
3)	TAWS FLTA Warning
4)	Obstruction Warning
5)	TAWS FLTA Caution
6)	Obstruction Caution
7)	GPWS Mode 4-1
8)	GPWS Mode 4-2
9)	GPWS Mode 4-3
10)	GPWS Mode 1 Caution
11)	GPWS Mode 2 Caution
12)	GPWS Mode 3
13)	GPWS Mode 5 Warning
14)	GPWS Mode 5 Caution
15)	Check Gear
16)	Traffic Warning (Resolution Advisory)
17)	Traffic Caution (Traffic Advisory)
18)	Low Fuel Warning
19)	Low Fuel Caution
20)	Fuel Split Caution
21)	Fuel Totalizer Mismatch Caution
22)	Check Range

In addition, flags are decluttered from all IDUs which are not “transmit enabled”. Flags only appear on non-talker IDUs if they are IDU-specific and cannot reasonably be shown on the talker (i.e., CHECK IDU #).

2.6. Database and Software Updates

2.6.1. Navigation and Obstruction Database

The EFIS uses Jeppesen NavData® for the navigation database and Jeppesen data for the obstruction database, which are secured directly through Jeppesen Sanderson, Inc.

The EFIS is updated through the Ground Maintenance Function (GMF). To gain access to the GMF, prior to applying power, slide the slip indicator or non-slip blank door cover at the bottom-center

of the IDU bezel upward to the first detent position to expose the USB port.

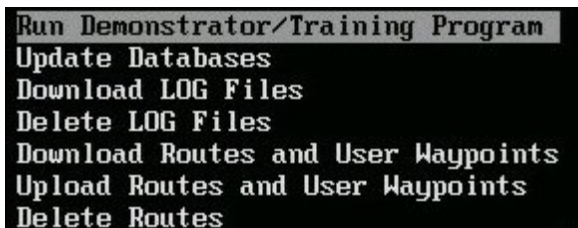


Figure 2-4: Ground Maintenance Page

2.6.2. Update Requirements

When an update is performed, the procedures must be performed separately on every IDU in the EFIS system. Scheduled updates are as follows:

Navigation Database Every 28 days

Obstruction Database Every 28 days

The EFIS Software and Terrain Database are unscheduled and/or on-condition and covered under Service Bulletin.

The Jeppesen Navigation and Obstruction databases may be accessed through www.jeppesen.com to place the order for the correct database.

Three types of navigation databases may be used on this EFIS.

Americas - Containing major airports and navigation for Alaska, Canada, Continental U.S., Hawaii, Puerto Rico, Bahamas, Bermuda, Mexico, Central, and South America.

International - Containing all available coverage except North and South America.

World - Containing major airports and navigation with the Americas.

The navigation database is loaded on each IDU by placing the program **navdata.exe** on a USB Memory card.

CAUTION:

Failure to update the EFIS with the correct navigation database causes the IDU to remain in continual reboot mode and does not allow any display page to appear.

CAUTION:

Always install a valid USB Memory Device in the IDU prior to activating any Ground Maintenance Function. Operation of the Ground Maintenance Function without a valid USB Memory Device installed may cause erroneous failure indications or corruption of the IDU.

The obstruction database is distributed by a government agency in each country. Not all countries have obstruction databases available.

Once the NavData database (navdata.exe) and obstruction database (obst.exe) are loaded on the USB memory device, insert the USB device into USB port with the power off. Turn power on to gain access to the GMF page. Scroll **1** to **“Update Databases”** and push to enter. Once each database is loaded, the pilot is prompted to press any KEY (button) or Encoder #1 to continue to complete the process. Once both databases have been successfully uploaded, power down the IDU, remove the USB memory device, and lower the USB door. Repeat this process for each IDU installed in the aircraft.

NOTE:

During a NavData update and a stored flight plan contains a waypoint which has been changed, it is either updated, or the flight plan is deleted during the update process.

```

REV 8.0D
P/N: 25-EFIS800-SU-0002
SOFTWARE OK (CPU NUMBER 1)
SOFTWARE CRC = 0X3B322426
AIRCRAFT TYPE GENERIC
NAVIGATION DATA: COVERAGE = WORLD (CYCLE1601)
VALID DATE 01-07-2016
EXPIRE DATE 02-04-2016
OBSTRUCTION DATA: DATE 02-04-2016
TERRAIN DATA: COVERAGE = S25W180 - N75E181
VALID DATE 05-26-2007
PRESS ANY KEY TO CONTINUE

```

Other Rotorcraft

```

REV 8.0D
P/N: 25-EFIS800-SU-0002
SOFTWARE OK (CPU NUMBER 1)
SOFTWARE CRC = 0X3B322426
GPS/SBAS LPU MODE ENABLED
AIRCRAFT TYPE AW109SP
NAVIGATION DATA: COVERAGE = WORLD (CYCLE1601)
VALID DATE 01-07-2016
EXPIRE DATE 02-04-2016
OBSTRUCTION DATA: DATE 02-04-2016
TERRAIN DATA: COVERAGE = S25W180 - N75E181
VALID DATE 05-26-2007
PRESS ANY KEY TO CONTINUE

```

Display of LPV Enable and
AFCS SW Part Number
(AW-109SP)

Figure 2-5: IDU-450 Startup Screen

Once each IDU has been updated, power up the entire EFIS system in normal flight mode and verify each IDU successfully updated with the latest database by noting the new NavData cycle expiration dates before acknowledging the startup screen. There is no expiration for the obstruction database.

Cyclic Redundancy Check (CRC) self-test at every step of the process verifies all data loaded into the IDU and ensures the data installed into the system was not corrupted at any point during the process.

The IDU provides an updateable navigation database containing at least the following location and path information, referenced to WGS-84, with a resolution of 0.01 minute (latitude/longitude) and 0.1° (for course information) or better at all of the following for the area(s) in which IFR operations are intended:

- 1) Airports;
- 2) VORs, DMEs (including DMEs collocated with localizers), collocated VOR/DMEs, VORTACs, and NDBs (including NDBs used as locator outer marker);
- 3) All named waypoints and intersections shown on enroute and terminal area charts;
- 4) All airways shown on enroute charts, including all waypoints, intersections, and associated RNP values (if applicable). Airways are retrievable as a group of waypoints (select the airway by name to load the appropriate waypoints and legs between the desired entry and exit points into the flight plan).

- 5) RNAV DPs and STARs, including all waypoints, intersections, and associated RNP values, if applicable. DPs and STARs are retrievable as a procedure (select the procedure by name to load the appropriate waypoints and legs into the flight plan).
- 6) LNAV approach procedures in the area(s) in which IFR operation is intended consist of:
 - a) Runway number and label (required for approach identification);
 - b) Initial Approach Waypoint (IAWP);
 - c) Intermediate Approach Waypoint(s) (IWP) (when applicable);
 - d) Final Approach Waypoint (FAWP);
 - e) Missed Approach Waypoint (MAWP);
 - f) Additional missed approach waypoints (when applicable); and
 - g) Missed Approach Holding Waypoint (MAHWP).

The complete sequence of waypoints and associated RNP values (if applicable), in the correct order for each approach, is retrievable as a procedure (select the procedure by name to load the appropriate waypoints and legs into the flight plan). Waypoints utilized as a final approach waypoint (FAWP) or missed approach waypoint (MAWP) in an LNAV approach procedure are uniquely identified as such (when appropriate) to provide proper approach mode operation.

- 7) LNAV/VNAV procedures in the area(s) where IFR operation is intended. LPV, LP, and/or LNAV/VNAV published procedures are available.

2.6.3. Terrain Database Update

The IDU-450 contains the entire World Terrain Database, which is updated on an as-needed basis as described in a service bulletin.

Section 3 Display Symbology

Table of Contents

SECTION 3	DISPLAY SYMBOLOGY	3-1
3.1.	INTRODUCTION.....	3-16
3.2.	PFD (PFI) SYMBOLOGY	3-16
3.2.1.	<i>IDU-450 PFD Display</i>	3-17
3.2.2.	<i>IDU-450 PFD Display (Basic Mode)</i>	3-18
3.2.3.	<i>IDU-450 MFD Display</i>	3-19
3.3.	MENU FUNCTIONS.....	3-20
3.3.1.	<i>Selecting BARO</i>	3-21
3.3.2.	<i>Selected Altitude Sub-Mode (Target Altitude)</i> .	3-22
3.3.3.	<i>VNAV Sub-Mode</i>	3-23
3.3.4.	<i>Altitude Display (VNAV Tile)</i>	3-25
3.3.5.	<i>Altitude Display (Metric Units)</i>	3-25
3.4.	PFD SYMBOLOGY	3-25
3.4.1.	<i>Minimum Altitude</i>	3-27
3.4.2.	<i>Vertical Speed Indicator</i>	3-27
3.4.3.	<i>Normal AGL Indication</i>	3-30
3.4.4.	<i>Analog AGL Indication</i>	3-31
3.4.5.	<i>Decision Height</i>	3-32
3.4.6.	<i>Airspeed Display</i>	3-33
3.4.7.	<i>Airspeed Display (With EFIS-Coupled)</i>	3-35
3.4.8.	<i>AW-109SP Airspeed Display</i>	3-36
3.4.9.	<i>Dynamically Calculated VNE</i>	3-37
3.4.10.	<i>Heading Display</i>	3-37
3.4.11.	<i>Heading Display (AW-109SP)</i>	3-39
3.4.12.	<i>Pitch Scale</i>	3-39

3.4.13.	<i>Pitch and Roll Scale (AW-109SP)</i>	3-40
3.4.14.	<i>Turn Rate Indicator</i>	3-41
3.4.15.	<i>Basic Mode</i>	3-41
3.4.16.	<i>Unusual Attitude Mode</i>	3-42
3.4.17.	<i>PFD Background</i>	3-43
3.4.18.	<i>Flight Path Marker (Velocity Vector)</i>	3-49
3.5.	HOVER VECTOR	3-52
3.6.	BANK ANGLE SCALE	3-53
3.6.1.	<i>Turn Indication</i>	3-54
3.7.	TIMER INDICATION	3-54
3.8.	MARKER BEACON SYMBOLOGY	3-54
3.9.	FLIGHT DIRECTOR SYMBOLOGY (FD1 SINGLE CUE)	3-55
3.9.1.	<i>Flight Director Symbology (FD2 Dual Cue)</i>	3-56
3.10.	LANDING GEAR INDICATION.....	3-57
3.11.	COURSE DEVIATION INDICATOR.....	3-58
3.12.	COURSE DEVIATION INDICATOR (AW-109SP)	3-60
3.12.1.	<i>OBS Setting of CDI</i>	3-61
3.12.2.	<i>Heading/Roll-Steering Sub-Mode</i>	3-61
3.13.	NO AUTOPILOT OR FULLY-INTEGRATED AUTOPILOT COURSE DEVIATION INDICATOR	3-62
3.13.1.	<i>Vertical Deviation Indicator</i>	3-62
3.13.2.	<i>Vertical Deviation Indicator (AW-109SP)</i>	3-65
3.13.3.	<i>Vertical Deviation Indicator (EFIS Coupled)</i>	3-67
3.13.4.	<i>Highway in the Sky/Skyway</i>	3-67
3.13.5.	<i>Highway in the Sky (AW-109SP)</i>	3-68
3.13.6.	<i>Active Waypoint and Waypoint Identifier</i>	3-68

3.13.7.	<i>Mini Map</i>	3-70
3.13.8.	<i>Mini Map and Active Waypoint Information Block (AW-109SP)</i>	3-70
3.13.9.	<i>Traffic Thumbnail</i>	3-72
3.13.10.	<i>Traffic Display Definitions</i>	3-72
3.13.11.	<i>Traffic Rendering Rules</i>	3-72
3.13.12.	<i>Runways</i>	3-74
3.13.13.	<i>Heliports</i>	3-76
3.13.14.	<i>AFCS Annunciations (AW-109SP)</i>	3-77
3.13.15.	<i>PFD in Command Arrow (AW-109SP)</i>	3-78
3.13.16.	<i>FMS LNAV and FMS VNAV Submode Annunciations (AW-109SP)</i>	3-78
3.13.17.	<i>AFCS Caution Alert Messages (AW-109SP)</i> ...	3-79
3.13.18.	<i>Link Fail Message (AW-109SP)</i>	3-79
3.13.19.	<i>Cyclic Cue (AW-109SP)</i>	3-80
3.13.20.	<i>Collective Cue and Symbol (AW-109SP)</i>	3-80
3.13.21.	<i>Horizon Synchronization (AW-109SP)</i>	3-81
3.13.22.	<i>Decision Height and Radar Height Readout (AW-109SP)</i>	3-82
3.14.	MFD SCREEN REQUIREMENTS (AW-109SP)	3-82
3.14.1.	<i>ND SCREEN</i>	3-82
3.14.2.	<i>Compass Rose Symbols (AW-109SP)</i>	3-83
3.14.3.	<i>HSI Overlay (AW-109SP)</i>	3-83
3.14.4.	<i>Active Leg of Active Flight Plan Path/Active Waypoint/Manual Course (AW-109SP)</i>	3-83
3.14.5.	<i>Identifier, Bearing, Distance and Time to Active Waypoint (AW-109SP)</i>	3-84
3.14.6.	<i>Swiss Grid (AW-109SP)</i>	3-84

3.15.	NAVIGATION DISPLAY SYMBOLOLOGY.....	3-85
3.15.1.	<i>Basic Moving Map</i>	3-85
3.15.2.	<i>Ownship Symbolology</i>	3-86
3.15.3.	<i>Compass Rose/ND Boundary Circle Symbol</i> ...	3-86
3.15.4.	<i>Moving Map with Instrument Approach</i>	3-86
3.15.5.	<i>North-Up Arc Mode</i>	3-87
3.15.6.	<i>North-Up Centered Mode</i>	3-87
3.15.7.	<i>Heading-Up Centered Mode</i>	3-88
3.15.8.	<i>Air Data and Groundspeed</i>	3-88
3.16.	CONVENTIONAL HSI/PTR FORMAT	3-89
3.16.1.	<i>Compass Rose Symbols</i>	3-92
3.16.2.	<i>HSI Screen (AW-109SP)</i>	3-94
3.16.3.	<i>Compass Rose Symbols (AW-109SP)</i>	3-94
3.16.4.	<i>Vertical Deviation Indicator (AW-109SP)</i>	3-95
3.16.5.	<i>Primary NAV Pointer (AW-109SP)</i>	3-95
3.16.6.	<i>NAV Preview Pointer (AW-109SP)</i>	3-95
3.16.7.	<i>Identifier, Bearing, Distance and Time to Active Waypoint (AW-109SP)</i>	3-96
3.16.8.	<i>Fuel Totalizer/Waypoint Bearing and Distance Functions</i>	3-96
3.16.9.	<i>Clock/Timers/Options</i>	3-98
3.17.	NAVIGATION LOG.....	3-100
3.17.1.	<i>Clock and Groundspeed</i>	3-100
3.17.2.	<i>Fuel Remaining and Fuel Flow Data</i>	3-100
3.17.3.	<i>Waypoint Identifier Column</i>	3-101
3.17.4.	<i>VNAV and VNAV Offset Column</i>	3-102
3.17.5.	<i>Path Column</i>	3-102

3.17.6.	<i>Distance Column</i>	3-103
3.17.7.	<i>Estimated Time Enroute Column</i>	3-103
3.17.8.	<i>Estimated Time of Arrival Column</i>	3-103
3.17.9.	<i>Fuel Remaining Column</i>	3-104
3.18.	START POINT.....	3-104
3.19.	ALTITUDE CAPTURE PREDICTOR.....	3-105
3.19.1.	<i>Top of Descent</i>	3-105
3.19.2.	<i>Projected Path</i>	3-106
3.20.	ACTIVE FLIGHT PLAN PATH/MANUAL COURSE/RUNWAYS.....	3-106
3.21.	FOV INDICATION.....	3-107
3.22.	RANGE.....	3-107
3.23.	NAVIGATION DATA.....	3-108
3.23.1.	<i>Air Data and Groundspeed</i>	3-110
3.23.2.	<i>Analog Navigation Symbology</i>	3-111
3.23.3.	<i>Borders</i>	3-112
3.23.4.	<i>Terrain/Obstructions</i>	3-112
3.24.	PAN MODE.....	3-114
3.25.	HSI SCREEN.....	3-115
3.25.1.	<i>HSI Screen VDI</i>	3-115
3.25.2.	<i>Analog Navigation Symbology</i>	3-116
3.25.3.	<i>HSI with Marker Beacon Displayed Air Data and Groundspeed</i>	3-117
3.25.4.	<i>Clock/Timers/Options</i>	3-118
3.25.5.	<i>Fuel Totalizer/Waypoint Bearing and Distance Functions</i>	3-119
3.26.	WX-500 DATA.....	3-119

3.26.1.	<i>Strike Screen Range</i>	3-120
3.26.2.	<i>Active Flight Plan Path/Manual Course/Runways...</i>	3-121
3.27.	DEDICATED TRAFFIC SCREEN	3-122
3.27.1.	<i>Ownship Symbol</i>	3-122
3.27.2.	<i>Traffic Screen Range</i>	3-123
3.27.3.	<i>Compass Rose Symbols</i>	3-123
3.27.4.	<i>Active Flight Plan Path/Manual Course/Runways...</i>	3-123
3.27.5.	<i>Dedicated Traffic Screen (AW-109SP)</i>	3-124
3.27.6.	<i>Compass Rose Symbols (AW-109SP)</i>	3-125
3.27.7.	<i>Active Leg of Active Flight Plan Path (AW-109SP).</i>	3-125
3.27.8.	<i>Identifier, Bearing, Distance and Time to Active Waypoint (AW-109SP)</i>	3-125
3.27.9.	<i>Dedicated Strike (WX-500) Screen (AW-109SP)</i>	3-126
3.27.10.	<i>Active Leg of Active Flight Plan Path (AW-109SP).</i>	3-126
3.27.11.	<i>Identifier, Bearing, Distance, and Time to Active Waypoint (AW-109SP)</i>	3-126
3.28.	DATALINK SYMBOLOGY	3-127
3.28.1.	<i>Datalink Screen Legend</i>	3-132
3.28.2.	<i>Air Data and Groundspeed</i>	3-132
3.28.3.	<i>Clock/Timers/Options</i>	3-132
3.28.4.	<i>Datalink Screen Orientation</i>	3-137
3.28.5.	<i>Datalink Screen Range</i>	3-137
3.28.6.	<i>Boundary Circle Symbol</i>	3-138

3.28.7.	<i>Active Flight Plan Path/Manual Course/Runways ..</i>	3-138
3.28.8.	<i>Borders</i>	3-139
3.28.9.	<i>Pan Mode</i>	3-139
3.29.	<i>HOVER SCREEN</i>	3-140
3.29.1.	<i>Ownship Symbol</i>	3-140
3.29.2.	<i>Hover Screen Orientation</i>	3-140
3.29.3.	<i>Hover Screen Range</i>	3-140
3.29.4.	<i>Hover Vector</i>	3-141
3.29.5.	<i>Compass Rose Symbols</i>	3-141
3.29.6.	<i>Active Flight Plan Path/Manual Course</i>	3-142
3.29.7.	<i>Navigation Data</i>	3-143
3.29.8.	<i>Projected Path</i>	3-144
3.29.9.	<i>Air Data and Groundspeed</i>	3-144
3.29.10.	<i>Clock and Timer</i>	3-144
3.29.11.	<i>AGL Indication</i>	3-145
3.29.12.	<i>Decision Height Indication</i>	3-146
3.29.13.	<i>Hover Screen (AW-109SP)</i>	3-147
3.29.14.	<i>Compass Rose Symbols (AW-109SP)</i>	3-147
3.30.	<i>HOVER VECTOR (AW-109SP)</i>	3-147
3.30.1.	<i>Groundspeed Reference (AW-109SP)</i>	3-147
3.30.2.	<i>A/C Acceleration Cue (AW-109SP)</i>	3-148
3.30.3.	<i>Active Flight Plan Path (AW-109SP)</i>	3-148
3.30.4.	<i>Air Data and Groundspeed (AW-109SP)</i>	3-149
3.30.5.	<i>AGL Indication</i>	3-149
3.30.6.	<i>Transition-Down Pre-Selection Bug and Readout (AW-109SP)</i>	3-150

3.30.7.	<i>Identifier, Distance, and Time to MOT Waypoint (AW-109SP)</i>	3-150
3.30.8.	<i>Nav Log Screen (AW-109SP)</i>	3-150
3.31.	PFD AND MFD SCREEN REQUIREMENTS (AW-109SP)	3-151
3.31.1.	<i>Hover Vector (AW-109SP)</i>	3-151
3.32.	WEATHER RADAR.....	3-151
3.32.1.	<i>Weather Screen Format</i>	3-152
3.32.2.	<i>Weather Screen Range</i>	3-153
3.32.3.	<i>Track Line</i>	3-154
3.32.4.	<i>Active Flight Plan Path/Manual Course/Runways...</i>	3-154
3.32.5.	<i>Weather Radar Return Data</i>	3-155
3.32.6.	<i>Air Data and Groundspeed</i>	3-157
3.32.7.	<i>Clock/Timers/Options</i>	3-157
3.32.8.	<i>Fuel Totalizer/Waypoint Bearing and Distance Functions</i>	3-161
3.33.	VIDEO INPUT SCREEN.....	3-161
3.33.1.	<i>ZOOM Level</i>	3-161
3.33.2.	<i>Pan Mode</i>	3-162
3.33.3.	<i>Video Input Status Display</i>	3-162

List of Figures and Tables

FIGURE 3-1: PFD	3-17
FIGURE 3-2: PFD IN BASIC MODE	3-18
FIGURE 3-3: PFD IN BASIC MODE (AW-109SP)	3-18
FIGURE 3-4: MFD	3-19
FIGURE 3-5: MFD (AW-109SP)	3-19
FIGURE 3-6: MENU FUNCTIONS	3-20
FIGURE 3-7: ENCODER FUNCTIONS FOR ALL PAGES	3-21
FIGURE 3-8: SELECTING BARO	3-21
FIGURE 3-9: ALTIMETER SETTING.....	3-22
FIGURE 3-10: ALTIMETER QFE	3-22
FIGURE 3-11: TARGET ALTITUDE BUG (VERTICALLY INTEGRATED)..	3-23
FIGURE 3-12: TARGET ALTITUDE BUG (NOT VERTICALLY INTEGRATED)	3-23
FIGURE 3-13: VNAV SUB-MODE (NOT VERTICALLY INTEGRATED)..	3-24
FIGURE 3-14: VNAV SUB-MODE (VERTICALLY INTEGRATED)	3-24
FIGURE 3-15: ALTITUDE DISPLAY (VNAV TILE).....	3-25
FIGURE 3-16: ALTITUDE DISPLAY (METRIC UNITS)	3-25
FIGURE 3-17: PFD SYMBOLOGY	3-26
FIGURE 3-18: PFD SYMBOLOGY (AW 109SP)	3-26
FIGURE 3-19: MINIMUM ALTITUDE	3-27
FIGURE 3-20: VSI	3-28
TABLE 3-1: SCALE GRADUATIONS AND DISPLAY	3-28
FIGURE 3-21: VSI BUG	3-29
FIGURE 3-22: VSI BUG (VERTICALLY INTEGRATED).....	3-29
FIGURE 3-23: NORMAL AGL INDICATION	3-30
TABLE 3-2: AGL INDICATION TO AVOID JUMPINESS	3-30
FIGURE 3-24: ANALOG AGL INDICATION.....	3-31
TABLE 3-3: ANALOG AGL INDICATOR	3-31
TABLE 3-4: ANALOG AGL INDICATOR MARKINGS.....	3-31
FIGURE 3-25: DECISION HEIGHT	3-32
FIGURE 3-26: AIRSPEED DISPLAY.....	3-33
FIGURE 3-27: AIRSPEED TREND.....	3-33
FIGURE 3-28: AIRSPEED SCALE FAR PART 27/29	3-34
FIGURE 3-29: AIRSPEED SCALE BUG.....	3-34
TABLE 3-5: AIRSPEED BUG LIMITS.....	3-34
TABLE 3-6: AIRSPEED BUG SETTING ANNUNCIATION AND BUG COLORS	3-35
FIGURE 3-30: AIRSPEED DISPLAY (WITH EFIS-COUPLED)	3-35
FIGURE 3-31: AIRSPEED DISPLAY (AW-109SP)	3-36
FIGURE 3-32: AIRSPEED SCALE (AW-109SP)	3-36
FIGURE 3-33: HEADING DISPLAY	3-37
FIGURE 3-34: SLIP/SKID INDICATOR	3-38

FIGURE 3-35: DISPLACED HEADING BUG.....	3-38
FIGURE 3-36: HEADING DISPLAY (AW-109SP)	3-39
FIGURE 3-37: PITCH SCALE.....	3-40
FIGURE 3-38: PITCH SCALE ZENITH AND NADIR SYMBOLS	3-40
FIGURE 3-39: PITCH AND ROLL SCALE (AW-109SP).....	3-41
FIGURE 3-40: TURN RATE INDICATOR	3-41
FIGURE 3-41: BASIC MODE	3-41
FIGURE 3-42: LANDING GEAR INDICATION	3-42
FIGURE 3-43: UNUSUAL ATTITUDE MODE.....	3-42
FIGURE 3-44: ROTORCRAFT PFD TERRAIN AND OBSTRUCTIONS.....	3-44
TABLE 3-7: LAT-LON RESOLUTION BOUNDARIES	3-45
TABLE 3-8: TERRAIN AND OBSTRUCTION RENDERING LEVELS	3-46
FIGURE 3-45: PFD WITH TERRAIN Deselected on PFD and Selected on MFD	3-47
FIGURE 3-46: PFD WITH OBSTRUCTIONS.....	3-48
FIGURE 3-47: FLIGHT PATH MARKER	3-49
FIGURE 3-48: FLIGHT PATH MARKER VIEWS	3-50
FIGURE 3-49: FLIGHT PATH MARKER ABSENT (UNUSUAL ATTITUDE MODE)	3-50
FIGURE 3-50: PFD WITH FLIGHT PATH MARKER REMOVED.....	3-51
FIGURE 3-51: PFD WITH GPS FAILURE AFTER 1 MINUTE	3-51
FIGURE 3-52: PFD HOVER VECTOR SYMBOLOLOGY	3-52
FIGURE 3-53: BANK ANGLE	3-53
FIGURE 3-54: TURN INDICATOR	3-54
FIGURE 3-55: TIMER	3-54
FIGURE 3-56: MARKER BEACONS	3-55
FIGURE 3-57: ROTORCRAFT FLIGHT DIRECTOR FD1 SINGLE CUE...3-55	
FIGURE 3-58: ROTORCRAFT FLIGHT DIRECTOR FD1 (BASIC MODE)3-56	
FIGURE 3-59: FLIGHT DIRECTOR FD2 (NORMAL MODE)	3-56
FIGURE 3-60: FLIGHT DIRECTOR FD2 (BASIC MODE)	3-57
FIGURE 3-61: LANDING GEAR INDICATION.....	3-57
FIGURE 3-62: COURSE DEVIATION INDICATOR.....	3-58
TABLE 3-9: CDI BEHAVIOR AND COLOR	3-59
FIGURE 3-63: COURSE DEVIATION INDICATOR (AW-109SP).....	3-60
TABLE 3-10: AW-109SP LATERAL NAVIGATION COLOR LOGIC	3-61
FIGURE 3-64: COURSE DEVIATION INDICATOR NO AUTOPILOT OR FULLY-INTEGRATED AUTOPILOT	3-62
TABLE 3-11: VERTICAL DEVIATION INDICATOR BEHAVIOR.....	3-63
FIGURE 3-65: VERTICAL DEVIATION INDICATOR.....	3-64
FIGURE 3-66: VERTICAL DEVIATION INDICATOR COLOR DURING GPS/SBAS LON OR VLON	3-65
FIGURE 3-67: VERTICAL DEVIATION INDICATOR COLOR (AW-109SP)	3-65
.....	3-65
TABLE 3-12: AW-109SP VERTICAL DEVIATION COLOR LOGIC	3-66

FIGURE 3-68: EFIS COUPLED VERTICALLY WITH GLIDESLOPE MODE ENGAGED	3-67
FIGURE 3-69: HIGHWAY IN THE SKY	3-67
FIGURE 3-70: HIGHWAY IN THE SKY (AW-109SP)	3-68
FIGURE 3-71: ACTIVE WAYPOINT	3-68
FIGURE 3-72: ACTIVE WAYPOINT (AW-109SP)	3-69
FIGURE 3-73: MINI MAP	3-70
FIGURE 3-74: MINI MAP AND ACTIVE WAYPOINT INFORMATION BLOCK (AW-109SP)	3-70
TABLE 3-13: MINI-MAP BEHAVIOR (WHEN NOT DECLUTTERED)	3-71
FIGURE 3-75: MINI MAP VOR SYMBOLOGY	3-71
FIGURE 3-76: TRAFFIC THUMBNAIL.....	3-72
TABLE 3-14: TRAFFIC RENDERING RULES.....	3-72
TABLE 3-15: PILOT SELECTED OT AND PA TRAFFIC ALTITUDE-FILTER... ..	3-73
TABLE 3-16: TRAFFIC SYMBOLOGY.....	3-73
FIGURE 3-77: TRAFFIC SYMBOLOGY.....	3-74
FIGURE 3-78: RUNWAYS	3-75
TABLE 3-17: RUNWAY DRAWING CRITERIA	3-76
FIGURE 3-79: HELIPADS	3-77
FIGURE 3-80: AFCS ANNUNCIATIONS (AW-109SP)	3-77
FIGURE 3-81: PFD SYMBOLOGY (AW-109SP).....	3-78
TABLE 3-18: (AW-109SP) FMS LNAV AND FMS VNAV SUBMODE ANNUNCIATIONS	3-79
FIGURE 3-82: AFCS CAUTION ALERT MESSAGES (AW-109SP).....	3-79
FIGURE 3-83: LINK FAIL MESSAGE (AW-109SP)	3-79
FIGURE 3-84: CYCLIC CUE (AW-109SP)	3-80
FIGURE 3-85: COLLECTIVE CUE AND SYMBOL (AW-109SP).....	3-80
FIGURE 3-86: HORIZON SYNCHRONIZATION (AW-109SP).....	3-81
FIGURE 3-87: DECISION HEIGHT AND RADAR HEIGHT READOUT (AW-109SP)	3-82
FIGURE 3-88: ND SCREEN (AW-109SP)	3-82
FIGURE 3-89: IDENTIFIER, BEARING, DISTANCE AND TIME TO ACTIVE WAYPOINT (AW-109SP)	3-84
FIGURE 3-90: SWISS GRID (AW-109SP).....	3-84
FIGURE 3-91: BASIC MOVING MAP	3-85
FIGURE 3-92: OWNERSHIP SYMBOLOGY	3-86
FIGURE 3-93: COMPASS ROSE/ND BOUNDARY CIRCLE SYMBOL	3-86
FIGURE 3-94: MOVING MAP WITH INSTRUMENT APPROACH	3-86
FIGURE 3-95: NORTH-UP ARC MODE	3-87
FIGURE 3-96: NORTH-UP CENTERED MODE	3-87
FIGURE 3-97: HEADING-UP CENTERED MODE	3-88
FIGURE 3-98: ND AIR DATA AND GROUND SPEED.....	3-88
FIGURE 3-99: CONVENTIONAL HSI/PTR FORMAT	3-89

FIGURE 3-100: CONVENTIONAL HSI/PTR FORMAT; HSI WITH VDI AND GLIDESLOPE	3-90
FIGURE 3-101: CONVENTIONAL HSI/PTR FORMAT WITH LOSS OF NAVIGATION CONDITION.....	3-91
FIGURE 3-102: ND (HSI WITH DME ON HOLD)	3-91
FIGURE 3-103: HSI OWNERSHIP SYMBOLS (CENTERED ON THE HSI AND POINTING STRAIGHT UP).....	3-91
FIGURE 3-104: COMPASS ROSE	3-92
FIGURE 3-105: HSI CDI SCALE.....	3-93
FIGURE 3-106: HSI CDI SCALE (WITH LON CONDITION)	3-93
FIGURE 3-107: HSI SCREEN (AW-109SP)	3-94
FIGURE 3-108: IDENTIFIER, BEARING, DISTANCE, AND TIME TO ACTIVE WAYPOINT (AW-109SP).....	3-96
FIGURE 3-109: FUEL TOTALIZER/WAYPOINT BEARING AND DISTANCE FUNCTIONS	3-96
TABLE 3-19: FUEL TOTALIZER/WAYPOINT BEARING AND DISTANCE FUNCTIONS	3-97
FIGURE 3-110: CLOCK AND TIMERS	3-98
TABLE 3-20: CLOCK/TIMERS/OPTIONS.....	3-99
FIGURE 3-111: NAVIGATION LOG	3-100
TABLE 3-21: GRAPHICAL METAR SYMBOLS	3-101
FIGURE 3-112: START POINT	3-105
FIGURE 3-113: TOP OF DESCENT OR TOP-OF-CLIMB.....	3-105
FIGURE 3-114: PROJECTED PATH	3-106
FIGURE 3-115: FIELD OF VIEW	3-107
FIGURE 3-116: RANGE.....	3-108
FIGURE 3-117: NAVIGATION DATA AND AIRSPACE DEPICTION	3-108
TABLE 3-22: AIRSPACE DEPICTION	3-109
FIGURE 3-118: AIR DATA AND GROUNDSPED	3-110
FIGURE 3-119: ANALOG NAVIGATION SYMBOLOLOGY	3-111
FIGURE 3-120: BORDERS.....	3-112
FIGURE 3-121: TERRAIN/OBSTRUCTIONS.....	3-112
TABLE 3-23: TERRAIN DISPLAY ON NAVIGATION DISPLAY COLOR RELATIONSHIP TO AIRCRAFT ALTITUDE	3-113
FIGURE 3-122: OBSTRUCTIONS	3-113
TABLE 3-24: OBSTRUCTIONS.....	3-113
FIGURE 3-123: PAN MODE	3-114
FIGURE 3-124: HSI POINTER COLOR.....	3-115
FIGURE 3-125: ANALOG NAVIGATION DISPLAY VOR1 AND VOR2	3-116
FIGURE 3-126: HSI BEARING DISTANCE READOUT WITH DME IN HOLD	3-116
FIGURE 3-127: HSI WITH MARKER BEACON DISPLAYED	3-117
FIGURE 3-128: HSI DISPLAY AIR DATA AND GROUNDSPED.....	3-117
FIGURE 3-129: HSI CLOCK/TIMERS.....	3-118

FIGURE 3-130: HSI FUEL TOTALIZER/WAYPOINT BEARING.....	3-119
TABLE 3-25: LIGHTNING STRIKES	3-119
FIGURE 3-131: LIGHTNING SYMBOLS.....	3-120
FIGURE 3-132: ACTIVE FLIGHT PLAN PATH/MANUAL COURSE/RUNWAYS	3-121
FIGURE 3-133: DEDICATED TRAFFIC SCREEN OWNERSHIP SYMBOL .	3-122
FIGURE 3-134: TRAFFIC DISPLAY FORMAT	3-122
FIGURE 3-135: TRAFFIC SCREEN RANGE COMPASS ROSE SYMBOLS.....	3-123
FIGURE 3-136: DEDICATED TRAFFIC SCREEN (AW-109SP).....	3-124
FIGURE 3-137: IDENTIFIER, BEARING, DISTANCE, AND TIME TO ACTIVE WAYPOINT (AW-109SP)	3-125
FIGURE 3-138: DEDICATED STRIKE (WX-500) SCREEN (AW-109SP) ...	3-126
FIGURE 3-139: IDENTIFIER, BEARING, DISTANCE, AND TIME TO ACTIVE WAYPOINT (AW-109SP)	3-126
FIGURE 3-140: DATALINK SYMBOLGY.....	3-127
TABLE 3-26: WSI INFLIGHT™ DATA PRODUCTS.....	3-127
TABLE 3-27: DATALINK NEXRAD RADAR DATA.....	3-128
TABLE 3-28: DATALINK NEXRAD ECHO TOPS.....	3-129
TABLE 3-29: DATALINK GRAPHICAL METARS.....	3-129
TABLE 3-30: GRAPHICAL METARS (GMETARS) SCREEN RANGE.....	3-129
FIGURE 3-141: NRST AIRPORT INFO.....	3-130
TABLE 3-31: DATALINK GRAPHICAL METAR PRECIPITATION	3-130
FIGURE 3-142: DATALINK WINDS AND TEMPERATURE ALOFT.....	3-131
FIGURE 3-143: DATALINK SCREEN LEGEND	3-132
FIGURE 3-115: CLOCK/TIMERS/OPTIONS.....	3-132
TABLE 3-32: DATALINK NEXRAD RADAR STATUS	3-133
FIGURE 3-144: DATALINK.....	3-137
TABLE 3-33: DATALINK SCREEN RANGE VALUES.....	3-137
FIGURE 3-145: BOUNDARY CIRCLE SYMBOL	3-138
FIGURE 3-146: OWNERSHIP SYMBOL	3-140
FIGURE 3-147: ND (HOVER VECTOR SCREEN)	3-140
FIGURE 3-148: HOVER VECTOR SYMBOLGY	3-141
FIGURE 3-149: ND (HOVER VECTOR COMPASS ROSE)	3-141
FIGURE 3-150: ND (HOVER VECTOR ACTIVE FLIGHT PLAN PATH/MANUAL COURSE).....	3-142
FIGURE 3-151: ND (HOVER VECTOR ACTIVE FLIGHT PLAN PATH/PARALLEL COURSE)	3-143
FIGURE 3-152: ND (HOVER VECTOR PROJECTED PATH).....	3-144
FIGURE 3-153: ND (HOVER VECTOR AGL INDICATION).....	3-145
TABLE 3-34: AGL INDICATION DESIGNED BEHAVIOR TO AVOID JUMPINESS.....	3-145

TABLE 3-35: ANALOG AGL INDICATION DESIGNED PARAMETERS ..	3-146
FIGURE 3-154: HOVER SCREEN (AW-109SP)	3-147
FIGURE 3-155: GROUNDSPED REFERENCE (AW-109SP)	3-148
FIGURE 3-156: A/C ACCELERATION CUE (AW-109SP)	3-148
FIGURE 3-157: AIR DATA AND GROUNDSPED (AW-109SP)	3-149
FIGURE 3-158: RADAR HEIGHT BUG AND READOUT (AW-109SP)	3-149
FIGURE 3-159: IDENTIFIER, DISTANCE, AND TIME TO MOT WAYPOINT (AW-109SP)	3-150
FIGURE 3-160: NAV LOG (AW-109SP).....	3-150
TABLE 3-36: WEATHER RADAR INHIBITED CONDITIONS	3-151
FIGURE 3-161: WEATHER RADAR IMAGE ON ND	3-152
FIGURE 3-162: RADAR IMAGE IN ARCED FORMAT	3-152
FIGURE 3-163: RADAR IMAGE IN PROFILE DEPICTION	3-153
FIGURE 3-164: RADAR TRACK LINE	3-154
FIGURE 3-165: RADAR ACTIVE FLIGHT PLAN.....	3-155
FIGURE 3-166: RADAR RETURN DATA	3-155
TABLE 3-37: WEATHER RADAR RETURN DATA	3-156
FIGURE 3-167: RADAR CLOCK/TIMER/OPTIONS	3-157
TABLE 3-38: RDR 2100 APPLICABILITY	3-158
TABLE 3-39: RDR 2100 MODE ANNUNCIATION	3-158
FIGURE 3-168: VIDEO PAN VIEW	3-162
FIGURE 3-169: VIDEO STATUS	3-163

3.1. Introduction

In an IFR installation, the software of the primary IDU-450 is configured so only the PFD is displayed. The software is configured on all other IDU-450 displays, so any screen display is shown at any time. On the AW-109SP, there is a PFD and MFD on each side of the cockpit.

The following section details the symbology used on the pilot and co-pilot Primary Flight Display (PFD) and Multi-Function Display (MFD) displays. The software of the pilot and co-pilot MFD may be configured to show **MAP**, **HSI**, **NAV LOG**, **STRIKES**, **TRAFFIC**, **DATALINK**, **HOVER**, **WX-RDR**, or **VIDEO** pages.

3.2. PFD (PFI) Symbology

The PFD combines pitot-static information, heading, attitude, 3-D navigation data, and more overlaid on a virtual background of the outside world. Other objects in the background, including terrain, obstructions, and runways are presented conformally as if seen directly in front of the aircraft while looking outside.

3.2.1. IDU-450 PFD Display



Figure 3-1: PFD

3.2.2. IDU-450 PFD Display (Basic Mode)

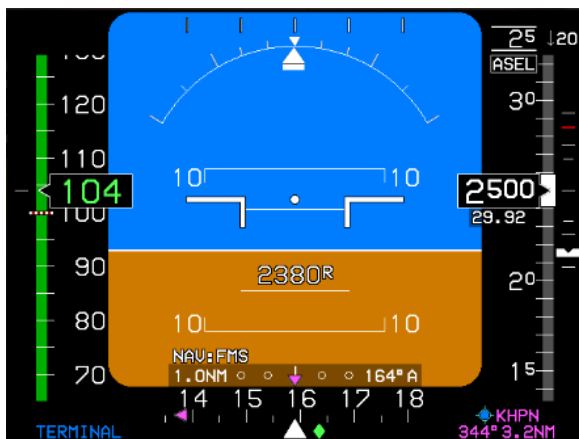


Figure 3-2: PFD in Basic Mode

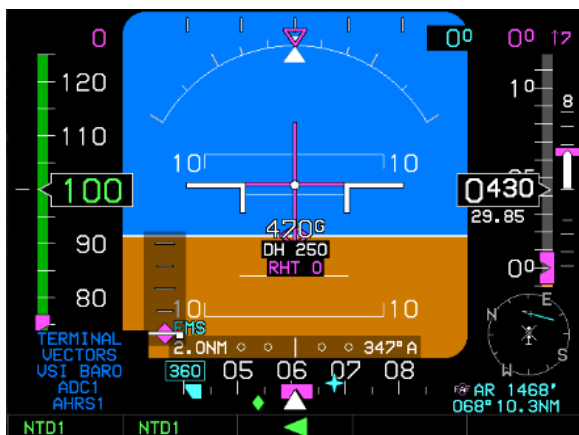


Figure 3-3: PFD in Basic Mode (AW-109SP)

When enabled through mode selection, the PFD Basic Mode is a traditional attitude display with the airspeed, altitude, and heading scales appearing in blacked-out areas in a “Basic-T” arrangement but is disabled while Unusual Attitude Mode is active. The following list of features is no longer present when the Basic Mode is displayed:

- | | |
|----------------------------|--------------------------------------|
| 1) Atmospheric perspective | 4) Flight Path Marker |
| 2) Terrain rendering | 5) Availability of Bank Scale option |
| 3) Obstructions rendering | 6) Airport runways |

3.2.3. IDU-450 MFD Display



Figure 3-4: MFD

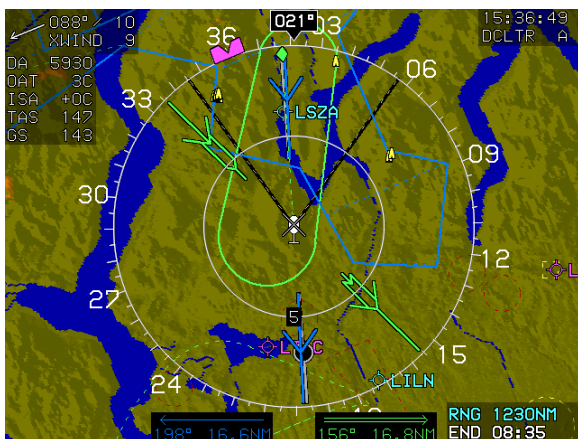
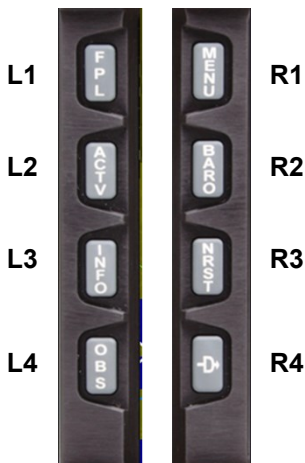


Figure 3-5: MFD (AW-109SP)

3.3. Menu Functions



The top-level menu level corresponds to the permanent labeling of the IDU pushbuttons and is active any time no soft menu options appear on the screen

Figure 3-6: Menu Functions

Soft menu function tiles appear next to the appropriate IDU button and the encoder when appropriate.

On the PFD, scroll the encoder to activate the heading menu. On the IDU-450, MFD pages which have an adjustable display (e.g., ND, Strike, Traffic, Datalink, Hover, or Weather Radar), scroll the encoder to change the display scale (clockwise = increase scale, counterclockwise = decrease scale).

On the video page, scroll the encoder to change the zoom level (clockwise = increase zoom, counterclockwise = decrease zoom).

With the exception of IDU #1, push the encoder to swap between the PFD and MFD, unless the IDU is in MFD-only mode. The IDU #1 is always configured to the PFD page.



PFD page

MFD MAP page

MFD Video page

MFD Datalink page

Figure 3-7: Encoder Functions for All Pages

Selection lists too long to be presented in the available space indicate the location within the list. When the menu system is beyond the top-level, **EXIT** appears adjacent to the top right pushbutton (**R1**) to provide one touch escape to the top-level. When a soft menu level is deeper than the first-level, **BACK** appears adjacent to the top left pushbutton (**L1**) to provide a method of regressing through the menu system by one level.

3.3.1. Selecting BARO



Figure 3-8: Selecting BARO

Press the **BARO** button to enter the BARO mode and view the inches of mercury (inHg) or millibars (mbar) value in the lower right corner on any IDU configured for any available page. Scroll **1**

clockwise to increase the QNH and counter clockwise to decrease the QNH. Push **1** to enter the new value.

The altimeter setting is displayed immediately below the altitude readout box and digitally displays the altimeter setting in either inches of mercury (inHg) or millibars (mbar) according to the pilot-selected units. Immediately below the altimeter setting, the mode is annunciated as QFE operations otherwise, no mode is annunciated.

QFE: Barometric setting resulting in the altimeter displaying height above a reference elevation (e.g., airport or runway threshold).

QNE: Standard barometric setting (29.92 inHg or 1013 mbar) used to display pressure altitude for flight above the transition altitude.

QNH: Barometric setting resulting in the altimeter displaying altitude above mean sea level at the reporting station.

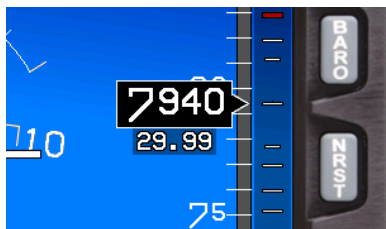


Figure 3-9: Altimeter Setting



Figure 3-10: Altimeter QFE

3.3.2. Selected Altitude Sub-Mode (Target Altitude)

When in selected altitude sub-mode, the altitude scale has a pilot-settable target altitude bug geometrically interacting with the altitude box pointer. The target altitude bug setting is limited to -1000 feet at

the low end, 50,000 feet at the high end, and is annunciated above the altitude scale as seen above with a resolution of 100 feet. For AW-109SP Remote Bugs Panel operation and setting of Altitude encoder for ALTA Datum, see § 5.20.2. Altitude Encoder (AW-109SP).



When in altitude hold mode, the target altitude bug setting annunciation is green, while the target altitude bug is filled-white.



When in a climb or descent mode, the target altitude bug setting annunciation is white, and the target altitude bug is hollow-white.

During altitude hold capture, the target altitude bug setting annunciation is green and flashes, while the target altitude bug is filled-white.

Figure 3-11: Target Altitude Bug (Vertically Integrated)



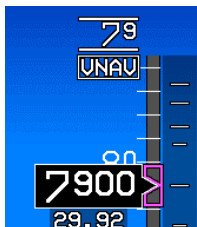
When not vertically integrated with an autopilot, the target altitude bug setting annunciation is white, and the target altitude bug is filled-white at all times.

Figure 3-12: Target Altitude Bug (Not Vertically Integrated)

3.3.3. VNAV Sub-Mode

When in VNAV sub-mode, the altitude scale shows the active waypoint VNAV altitude (if it exists) with a bug symbol geometrically interacting with the altitude box pointer. The VNAV altitude bug

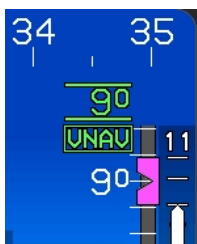
setting is annunciated above the altitude scale with a resolution of 100 feet.



When not vertically integrated with a fully-integrated digital autopilot, the VNAV altitude bug setting annunciation includes a legend with the abbreviation “VNAV” indicating the VNAV altitude sub-mode.

When vertically integrated with a fully-integrated digital autopilot, this legend is not needed because an equivalent indication appears in the autopilot mode annunciation area. The VNAV altitude bug may be used either as a visual reference, or when vertically integrated with an autopilot either fully or partially integrated through use of the vertical mode discrete input, as a control parameter for climbs or descents.

Figure 3-13: VNAV Sub-Mode (Not Vertically Integrated)



When vertically integrated with an autopilot:

When in altitude hold mode, the VNAV altitude bug setting annunciation is green, and the VNAV altitude bug is filled-magenta.

The VNAV altitude bug setting annunciation is green and flashes, while the VNAV altitude bug is filled-magenta during altitude hold capture.



When in a climb or descent mode, the VNAV altitude bug setting annunciation is white, and the VNAV altitude bug is hollow-magenta.

Figure 3-14: VNAV Sub-Mode (Vertically Integrated)

When the VNAV altitude or target altitude differs from aircraft altitude to the extent the associated bug is off-scale, the associated bug is “parked” in the direction of the difference with half of the associated bug visible as seen in Figure 3-14.

3.3.4. Altitude Display (VNAV Tile)

When enabled for performing VNAV with a manually selected altitude entered, **VNAV** appears for “one-touch” engagement of VNAV.

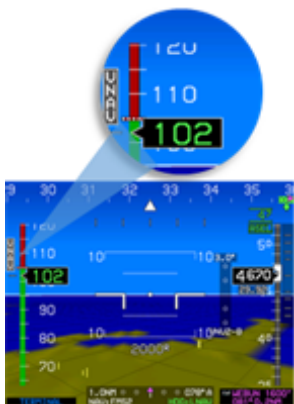


Figure 3-15: Altitude Display (VNAV Tile)

For AW-109SP Remote Bugs Panel operation and setting of altitude display for VNAV/LNAV operation, see § 5.20.5. VNAV Button (AW-109SP).

3.3.5. Altitude Display (Metric Units)



Other Rotorcraft

AW-109SP

Pilot-selectable altitude values are in metric units with a resolution of 10 meters as depicted.

Figure 3-16: Altitude Display (Metric Units)

3.4. PFD Symbolology

The PFD combines pitot-static information, heading, attitude, 3-D navigation data, and more overlaid on a virtual background of the outside world. Other objects in the background, including terrain,

obstructions, traffic, and runways are presented conformably as if seen directly in front of the aircraft while looking outside.



Figure 3-17: PFD Symbology

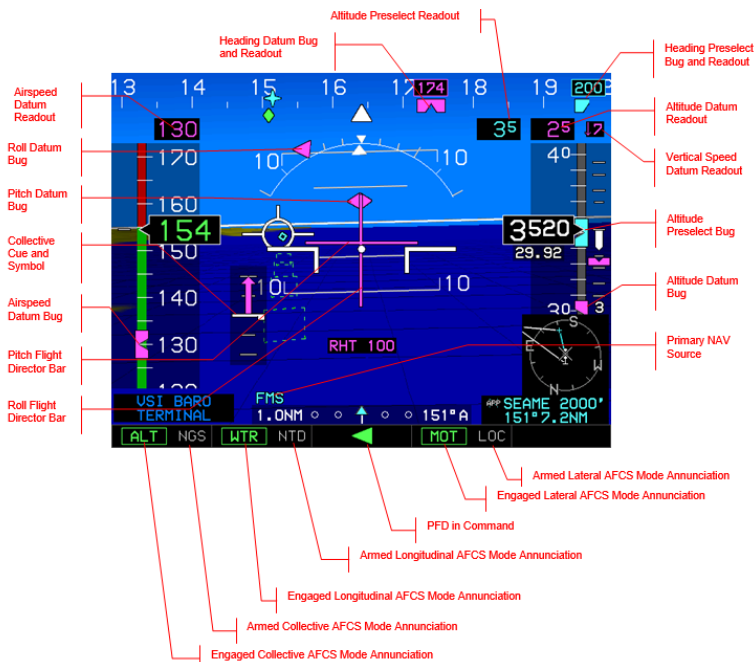


Figure 3-18: PFD Symbology (AW 109SP)

3.4.1. Minimum Altitude



Figure 3-19: Minimum Altitude

When a minimum altitude is selected (in 10-foot increments), a bug in the form of a bold amber (yellow) bar is displayed in the appropriate position on the altitude tape and below in amber (yellow).

The minimum altitude setting is indicated above the altitude tape with a line drawn below. In Figure 3-19, 6000' MSL is set.

Minimum and target altitude/VNAV altitude bugs may be used simultaneously.



Audible Annunciation

When a minimum altitude is set, descending from above to below causes an aural annunciation of "Minimums, Minimums", and the minimum altitude turns amber (yellow) and flashes.

3.4.2. Vertical Speed Indicator

A vertical speed indicator (VSI) is located to the right of the altitude box. The VSI is depicted as a "worm" format and provides an analog and digital representation of VSI in feet per minute.

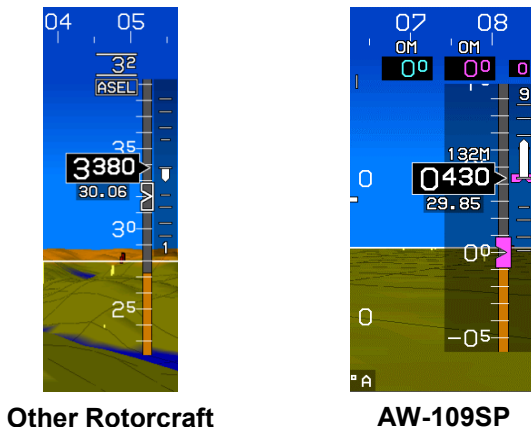


Figure 3-20: VSI

Table 3-1: Scale Graduations and Display

Type Traffic Installed	Scale Limit	Scale Graduations and Display
With TCAS-II	$\pm 2,000$ FPM	± 500 , $\pm 1,000$, and $\pm 2,000$ The background of the VSI functions as an RA display with green and red colored regions to provide RA maneuver guidance.
Without TCAS-II	$\pm 2,000$ FPM	± 500 , $\pm 1,000$, and $\pm 2,000$ FPM

The VSI worm grows in proportion to the square root of the vertical speed so a change near 0 feet per minute displaces the worm to a much greater degree than an equivalent change at a larger feet per minute value. Readouts of vertical speed rounded to the nearest 100 feet per minute appear above the VSI scale (for climbs) or below the VSI scale (for descents).

The AW-109SP VSI includes a Vertical Speed Bug Datum bug geometrically interacting with the VSI pointer annunciated above the VSI scale with a resolution of 100 feet per minute. This value is magenta with an arrow of the same color pointing in the direction of the Vertical Speed Datum. This bug is filled-magenta at all times.

For enhanced night visibility, the background of the Vertical Speed Datum Bug value annunciation is blacked-out.



The pilot-selectable VSI bug setting (100' FPM resolution) in this example is set to 1000 FPM descent rate.

Figure 3-21: VSI Bug

The vertical speed bug is used either as a visual reference or, when vertically integrated with an autopilot (either fully integrated or partially integrated through use of the vertical mode discrete input), as a control parameter for climbs or descents. It is mutually exclusive with the airspeed bug.

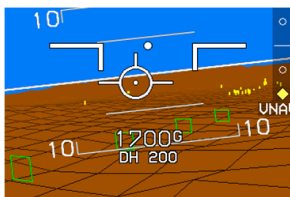


When vertically integrated with an autopilot, the VSI bug setting annunciation is green with the speed bug filled-white when in VSI climb or descent mode. Otherwise, the VSI bug setting is white, and VSI bug is hollow-white.

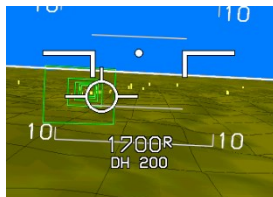
When not vertically integrated with an autopilot, the vertical speed bug setting annunciation is white, and the vertical speed bug is filled-white at all times.

Figure 3-22: VSI Bug (Vertically Integrated)

3.4.3. Normal AGL Indication



(SVS Basic) AGL Based on GPS Altitude



(SVS TAWS) AGL Based on Radar Altimeter

Figure 3-23: Normal AGL Indication

AGL altitude is displayed in two formats; one at the bottom-center of the display above the Course Deviation Indicator (Normal) and as the (Analog) AGL Indicator described below. These are mutually exclusive of each other and driven by whatever AGL altitude source is used for a TAWS system but not displayed when the source is invalid. A source indication appears to designate the source for either format as follows:

- 1) R = Radar altitude.
- 2) G = GPS/SBAS geodetic height less database ground elevation.
- 3) B = Barometric altitude less database ground elevation.

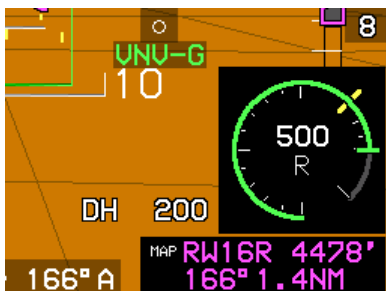
AGL indication designed behavior to avoid jumpiness.

Table 3-2: AGL Indication to Avoid Jumpiness

Altitude	300 Feet	≥ 100 Feet < 300Feet	<100 Feet
AGL Indication resolution	10 Feet	5 Feet	1 Foot

AGL altitude is not displayed in either format when it is greater than the radar altimeter maximum valid altitude but not displayed when it is invalid. Additionally, the AGL indication includes a display of the currently set decision height. This is accompanied by “Decision Height” aural annunciation, and the decision height display and readout turn amber (yellow) and flash.

3.4.4. Analog AGL Indication



A pilot-selectable analog AGL indication is displayed in the lower right corner of the PFD above the active waypoint identifier with a green circular tape and digital readout in the center. The circular tape has a radial line at its end and disappears above 1000' AGL.

Figure 3-24: Analog AGL Indication

Table 3-3: Analog AGL Indicator

Analog AGL Indicator Markings 0-1000 Feet		AGL	Scaling (at clock position)
0-100 Feet	100 Feet-1000 Feet	0' AGL	6:00
Linear	Logarithmic	50' AGL	9:00
		100' AGL	12:00
		200' AGL	1:30
		500' AGL	3:00

Table 3-4: Analog AGL Indicator Markings

	Major Tick Marks	Minor Tick Marks
0'	✓	
10'		✓
20'		✓
30'		✓
40'		✓
50'	✓	
60'		✓
70'		✓
80'		✓
90'		✓

Table 3-4: Analog AGL Indicator Markings

	Major Tick Marks	Minor Tick Marks
100'	✓	
200'		✓
300'		✓
400'		✓
500'	✓	
1000'	✓	

The Analog AGL indicator disappears in Unusual Attitude mode and is mutually exclusive with the Mini-Map and Traffic Thumbnail. Likewise, when the Analog AGL altitude display is shown, the normal AGL display is removed.

3.4.5. Decision Height

The analog AGL indication includes a display of the currently set decision height to the left of the indication along with an amber (yellow) radial line on the circular tape.

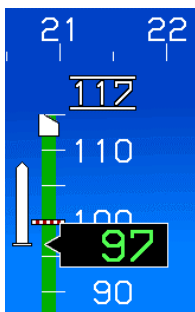


The decision height turns amber (yellow) and flashes when the aircraft descends below decision height from above. When below decision height, the circular tape and digital readout are amber (yellow). This is accompanied by a “Decision Height” aural annunciation, and decision height readout turns amber (yellow) and flashes.

Figure 3-25: Decision Height

3.4.6. Airspeed Display

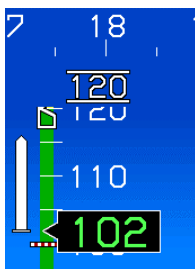
Airspeed is digitally displayed in same color as airspeed scale in knots, miles per hour, or kilometers per hour with interactive pointer. The airspeed scale is commensurate with the certification category of the aircraft.



The airspeed box pointer interacts with the airspeed scale and has graduations every five measurement units with labels every 10 measurement units with high numbers at the top.

The airspeed scale range has at least 40-75 measurement units. During an ADC failure, a red "X" is displayed in place of the airspeed scale.

Figure 3-26: Airspeed Display



The airspeed trend vector is calculated along the rotorcraft longitudinal axis in a "worm" format to provide analog representation of IAS achieved in five seconds assuming the instantaneous longitudinal acceleration is maintained.

Figure 3-27: Airspeed Trend



The airspeed scale for Part 27 and Part 29 rotorcraft has additional specific airspeed markings as follows:

A red cross-hatched line at V_{NE} (power-off).

If enabled (white triangle not 0), a white triangle translational lift reference speed marker.

Figure 3-28: Airspeed Scale FAR Part 27/29



Airspeed bug is parked in the direction of the difference if airspeed off scale.

Figure 3-29: Airspeed Scale Bug

The airspeed scale has a pilot-settable airspeed bug that is filled-white at all times and geometrically interacts with the airspeed box pointer, which is white. The airspeed bug is annunciated above the airspeed scale with a resolution of one knot indicated airspeed used only as a visual reference and is mutually exclusive with the vertical speed bug.

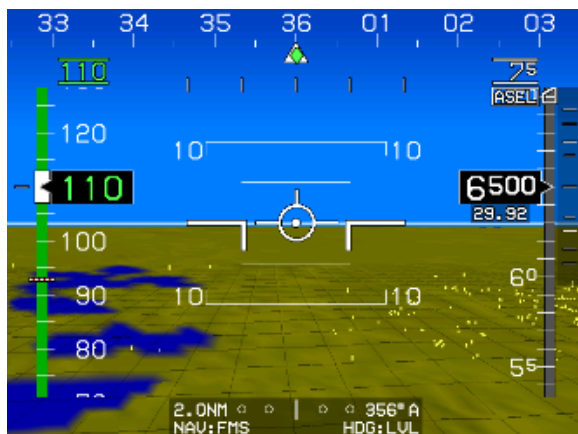
When the airspeed bug setting differs from aircraft airspeed to the extent the airspeed bug is off-scale, the airspeed bug appears to be “parked” in the direction of the difference with half of the airspeed bug visible as seen in Figure 3-29.

Table 3-5: Airspeed Bug Limits

Table 3-5: Airspeed Bug Limits	
Low end	High end
V_{MIN}	Red-line (V_{NE})

Table 3-6: Airspeed Bug Setting Annunciation and Bug Colors		
	Without vertically integrated autopilot	With vertically integrated autopilot
Airspeed bug setting annunciation color	White at all times	Green when in airspeed climb or descent mode otherwise white
Airspeed bug	Filled-white at all times	Filled-white when in airspeed climb or descent mode otherwise hollow-white

3.4.7. Airspeed Display (With EFIS-Coupled)



Airspeed descent to 7,500' with green color and filled airspeed

Figure 3-30: Airspeed Display (with EFIS-Coupled)

3.4.8. AW-109SP Airspeed Display



The airspeed scale includes an Airspeed Datum Bug which geometrically interacts with the airspeed box pointer and is magenta-filled. When limited at the edge of the airspeed scale, the bug is cropped. The Airspeed Datum readout is annunciated in magenta above the airspeed scale with a resolution of 1 KIAS.

Figure 3-31: Airspeed Display (AW-109SP)

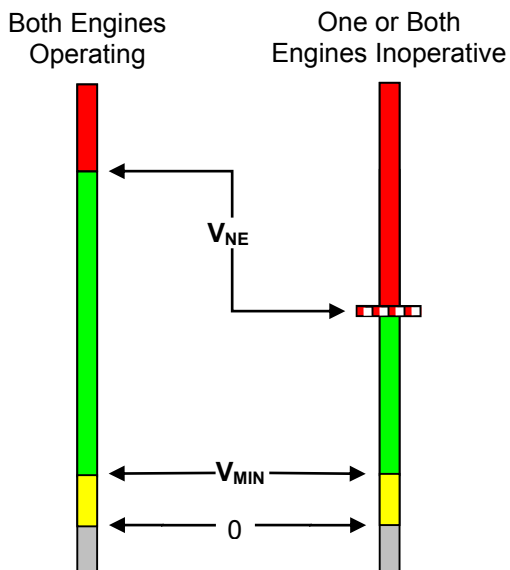


Figure 3-32: Airspeed Scale (AW-109SP)

When either engine is failed, a red and white barber pole is displayed at V_{NE} on the airspeed scale. Between V_{MIN} and 0 knots, the background color of the airspeed scale is amber (yellow), but the text of the Airspeed Readout remains gray.

In approach mode, groundspeed is displayed immediately below the airspeed box with a gray-shaded background. To enhance night visibility, the background of the Airspeed Scale is gray-shaded, and the background of the Airspeed Datum Readout is blacked-out.

3.4.9. Dynamically Calculated V_{NE}

V_{NE} has two different subcategories which are V_{NE} with retractable landing gear and V_{NE} with fix extended landing gear. V_{NE} is dynamically determined based on outside air temperature, altitude, engine status, and landing gear status. (See AW-109SP Rotorcraft flight manual for V_{NE} calculation and corrections based outside air temperature, altitude, engine status, and landing gear status).

3.4.10. Heading Display



Figure 3-33: Heading Display

The PFD heading scale across the top of the display is aligned with magnetic north with graduations every 5° with major graduations and heading labels every 10° . These graduations and digits of the heading scale are equally spaced so, at an aircraft roll angle of zero, they approximately conform to the three-dimensional PFD background. The heading scale includes a triangular white heading pointer aligned with the longitudinal axis of the aircraft with a slip indicator.

An integral slip indicator is provided and may replace the mechanical slip indicator mounted in the bezel. The slip indicator is a rectangle just below the heading pointer that moves left and right to indicate the lateral acceleration sensed by the AHRS in the same manner as the ball in a mechanical slip indicator. The integral slip indicator is responsive to lateral (Y-axis) G-force (the slip indicator is the white rectangular part of the heading pointer) and is damped, so it approximately matches a conventional glass vial indicator.



Figure 3-34: Slip/Skid Indicator

The heading scale has a green, diamond-shaped track pointer aligned with the aircraft's track across the earth. When the aircraft's track is displaced from aircraft heading beyond the boundaries of the PFD screen, the track pointer is drawn at the limit of the heading scale in the direction of the displacement, and the aircraft track value is displayed in a solid green box above the track pointer as seen in Figure 3-35. The track pointer is not displayed when indicated airspeed is in the noise range (when indicated airspeed or groundspeed is less than 20 KIAS).

The heading scale has a pilot-settable heading bug symbol designed to geometrically interact with the heading pointer. When the heading bug is set, the heading bug value is displayed in a white bordered black box above the heading bug symbol for a period of five seconds. When the heading bug value is displaced from aircraft heading beyond the boundaries of the PFD screen, the heading bug symbol is drawn halved at the limit of the heading scale in the direction of the displacement, and the heading bug value is displayed in a white bordered black box above the heading bug symbol as seen in Figure 3-35.



Figure 3-35: Displaced Heading Bug

When an active waypoint exists, the heading scale includes a magenta, star-shaped waypoint pointer at a point corresponding with the active waypoint. When the waypoint pointer is displaced from aircraft heading beyond the boundaries of the PFD screen, the waypoint pointer is replaced by a magenta, triangular arrow at either the far-right or far-left limit of the heading scale to indicate the shortest (not necessarily the safest) direction of turn to the active waypoint as seen above. The waypoint pointer and shortest

direction of turn indications turn amber (yellow) in the event of GPS Loss of Navigation caution.

3.4.11. Heading Display (AW-109SP)



Figure 3-36: Heading Display (AW-109SP)

The heading scale includes a Heading Datum Bug and a Heading Preselect Bug geometrically interacting with the heading pointer. The Heading Datum Bug is filled-magenta, and the Heading Preselect Bug is filled-cyan. When commanded by the AFCS or when a heading bug is limited at the edge of the heading scale, a digital readout is displayed above the bug. When the two bugs overlap, the Heading Datum Bug is on top of the Heading Preselect Bug. When either heading bug is limited at the edge of the heading scale, the bug is cropped. If both bugs are limited at the edge of the heading scale in the same direction, the Heading Preselect Bug is offset inward so both bugs are visible.

When an active waypoint exists, the color of the star-shaped waypoint pointer or the triangular arrow indicating the direction of an off scale waypoint is determined using Table 3-10.

3.4.12. Pitch Scale

Rotation of the background, pitch scale, and background oriented display elements occur relative to the location of the waterline symbol or Large Aircraft Reference Marks.

The pitch scale and double width horizon line, which rotates in conjunction with the background according to the aircraft's roll angle, have increments every 5° with major increments and pitch scale labels every 10°. Increments are equally spaced to approximately conform to the three-dimensional PFD background. Pointer bars at the ends of each major increment indicate the direction to the horizon and automatically declutter to present the fewest possible increments needed to unambiguously display pitch attitude. The pitch scale terminates with a zenith symbol (small white circle) at +90° and a nadir symbol (small white circle with "+") at -90° (see Figure 3-38).



Figure 3-37: Pitch Scale

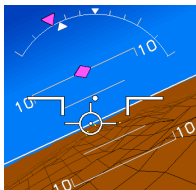
The PFD has Large Aircraft Symbol Reference Marks fixed in the center of the display. Rotation of the background, pitch scale, and background oriented display elements occur relative to the location of the Large Aircraft Symbol Reference Marks.



Figure 3-38: Pitch Scale Zenith and Nadir Symbols

3.4.13. Pitch and Roll Scale (AW-109SP)

The Roll Datum Bug is a magenta equilateral triangle moving along the roll scale to indicate the AFCS commanded roll datum. When the AFCS communicates roll datum to the EFIS, the Roll Datum Bug is filled-magenta.



The Pitch Datum Bug is a magenta diamond which moves along the Pitch Scale to indicate the AFCS commanded pitch datum. When the AFCS communicates pitch datum value to the EFIS, the Pitch Datum Bug is filled-magenta, otherwise it is hollow-magenta.

Figure 3-39: Pitch and Roll Scale (AW-109SP)

3.4.14. Turn Rate Indicator



A turn rate indicator is displayed in the upper center of the PFD just below the heading pointer when selected and has standard rate and half standard rate graduations with a horizontal

worm magnitude presentation. The full scale for the turn rate indicator worm is at least 20 pixels beyond the standard rate turn graduation allowing the pilot to fly a standard rate turn.

Figure 3-40: Turn Rate Indicator

3.4.15. Basic Mode

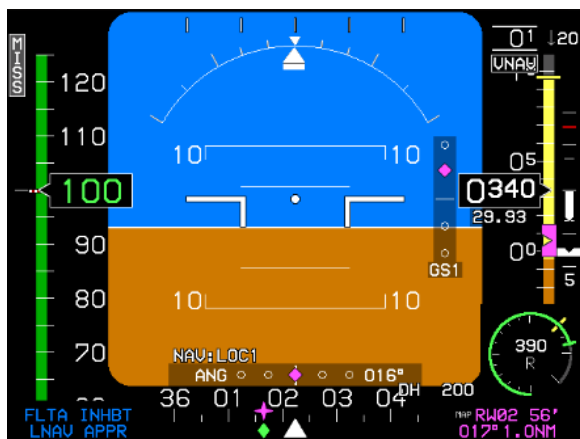
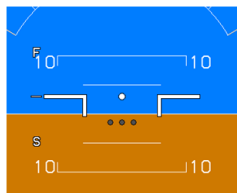


Figure 3-41: Basic Mode


Normal Mode

Basic Mode
Figure 3-42: Landing Gear Indication

In the Normal Mode and Basic modes, the PFD displays landing gear as shown in Figure 3-42. The following features are no longer present when the Basic mode is displayed:

- | | |
|----------------------------|------------------------|
| 1) Atmospheric perspective | 5) Roll Pointer option |
| 2) Terrain rendering | 6) Bank Scale option |
| 3) Obstructions rendering | 7) Airport runways |
| 4) Flight Path Marker | |

3.4.16. Unusual Attitude Mode


Figure 3-43: Unusual Attitude Mode

Unusual Attitude Mode is enabled when the pitch attitude exceeds $+30^\circ$ or -30° or bank angle exceeds 50° . Once enabled, the Unusual

Attitude Mode remains engaged until pitch attitude returns to within 5° of the horizon and bank attitude returns to within 10° of the horizon. Recovery chevrons tied to the 30° and higher pitch scale indications (both positive and negative) aid in unusual attitude recovery and are a normal part of the pitch scale and are not necessarily tied to unusual attitude mode.

NOTE:

The recovery chevrons are a normal part of the pitch scale but are not necessarily tied to unusual attitude mode.

The following features are disabled in the Unusual Attitude mode:

- | | |
|--------------------------------------|--|
| 1) Terrain and obstruction rendering | 8) Active Waypoint symbology |
| 2) CDI | 9) Mini Map |
| 3) VDI | 10) Traffic thumbnail |
| 4) Flight Path Marker | 11) If in Basic Mode, PFD reverts to Normal Mode |
| 5) Highway in the Sky boxes | 12) If in Zoom mode FOV, PFD reverts to normal FOV |
| 6) Atmospheric perspective | 13) Runways |
| 7) Analog and digital AGL indication | |

3.4.17. PFD Background

The PFD has a three-dimensional background generated from terrain elevation and obstruction elevation data stored in electronic memory. The “actual horizon” displayed on the PFD is based upon the higher of terrain within 90NM or a horizon calculated using a visible horizon equation (e.g., horizon [NM] = 1.17 x sq. root alt in feet). Thus, the relative elevation of terrain and obstructions with respect to aircraft altitude and performance is observed by reference to the primary flight information pitch ladder and flight path marker.

The background has two pilot-selectable field-of-view (FOV) modes, wide FOV mode (approximately 70°) and narrow FOV mode (approximately 35°). In Unusual Attitude Mode, wide FOV mode is automatically selected.

The terrain and obstruction rendering uses hidden surface removal techniques, while terrain/sky rendering uses atmospheric perspective techniques. Terrain with obstruction rendering is collectively pilot-selectable to declutter the display (*independent declutter of obstructions is not possible*). Terrain and obstruction rendering is disabled in Basic Mode, Unusual Attitude Mode, and during any reversionary mode. In Unusual Attitude Mode, the blue-brown boundary line of the background decouples from the pitch scale at high pitch angles so a sliver of the blue-brown boundary line always remains visible to give guidance to the horizon.

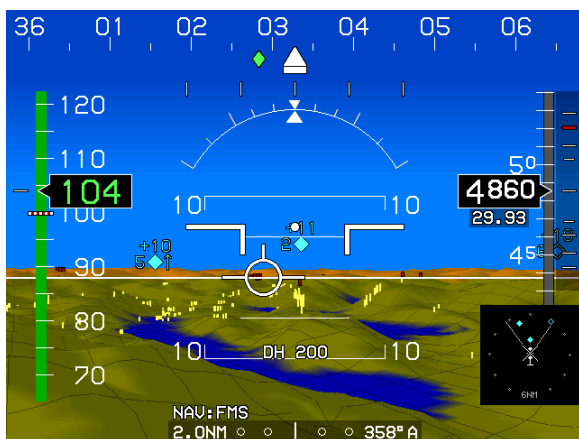


Figure 3-44: Rotorcraft PFD Terrain and Obstructions

The terrain ahead of the aircraft is shown conformally with the artificial horizon in the correct scale and perspective for the aircraft's current position and altitude. Worldwide terrain coverage is provided in each IDU and is shown with a resolution as shown in Table 3-7.

Terrain is displayed ahead of the aircraft using a grid and simulates “atmospheric perspective” (the terrain lines fade into the background “ground” color as they recede into the distance). This enhances the three-dimensional effect, improves distance judging, and eliminates foreground occlusion (object in the foreground cannot be seen against a similar background). Furthermore, an actual horizon is depicted based upon an aircraft altitude like the real horizon. Distance varies to create a realistic depiction of the horizon.

At latitudes greater than 75°, no grid lines are shown. To keep the grid spacing relatively consistent, at latitudes between 45° and 75°, the longitude spacing is increased according as follows.

Table 3-7: LAT-LON Resolution Boundaries

Latitude Range	Longitude Grid Spacing	Heading Boundary	
		Pole	Equator
0° to 46°	24 arc-seconds		
46° to 62°	48 arc-seconds	46°	45°
62° to 70°	72 arc-seconds	62°	61°
70° to 74°	96 arc-seconds	70°	69°
74° to 75°	120 arc-seconds	74°	73°

NOTE:

There is a one degree dead band to prevent grid flicker while flying along one of the boundary latitudes. The grid space switching changes at one degree less latitude when flying towards the Equator than it does when flying toward the Poles.

A blended-tone sky is displayed in conjunction with terrain. The sky fades from light blue at the horizon to dark blue at the top of the display to simulate atmospheric perspective and enhance the 3-D presentation. Additionally, the blended sky increases contrast of the directional scale, emphasizes the horizon, and provides a compelling visual cue to a nose-high attitude.

Table 3-8: Terrain and Obstruction Rendering Levels

Feature	Terrain Rendering Coloring	Notes
SVS BASIC	Shades of brown for non-water terrain. Deep blue denotes areas of water and takes precedence over the shades of brown.	Amber and red colors not used for normal display of terrain.
SVS TAWS	Shades of olive when at or below 100 feet less than aircraft altitude. Shades of brown when above 100 feet than aircraft altitude. Deep blue denotes areas of water and takes precedence over other colors. TAWS coloring of FLTA alert or warning cells.	Amber and red colors used for normal display of terrain. Amber and red colors used to show terrain areas causing FLTA alerts.
None	No terrain or obstructions are shown. Neither, SVS BASIC or SVS TAWS is selected.	

WARNING:

DO NOT USE THIS EFIS FOR TERRAIN-FOLLOWING FLIGHT. DO NOT ATTEMPT TO NAVIGATE USING THE TERRAIN DEPICTION. ALWAYS ADHERE TO PUBLISHED NAVIGATIONAL INSTRUMENT PROCEDURES AND NAVIGATIONAL CHARTS IN ALL FLIGHT CONDITIONS.

When terrain and obstruction rendering is deselected or disabled, the PFD screen background is a conventional blue over brown attitude display presentation without atmospheric perspective. Additionally, terrain may be deselected on the PFD and retained on the ND MAP display as seen in Figure 3-45.

WARNING:

MANY TOWERS, ANTENNAS, STRUCTURES, AND OBSTRUCTIONS ARE NOT IN THE DATABASE.

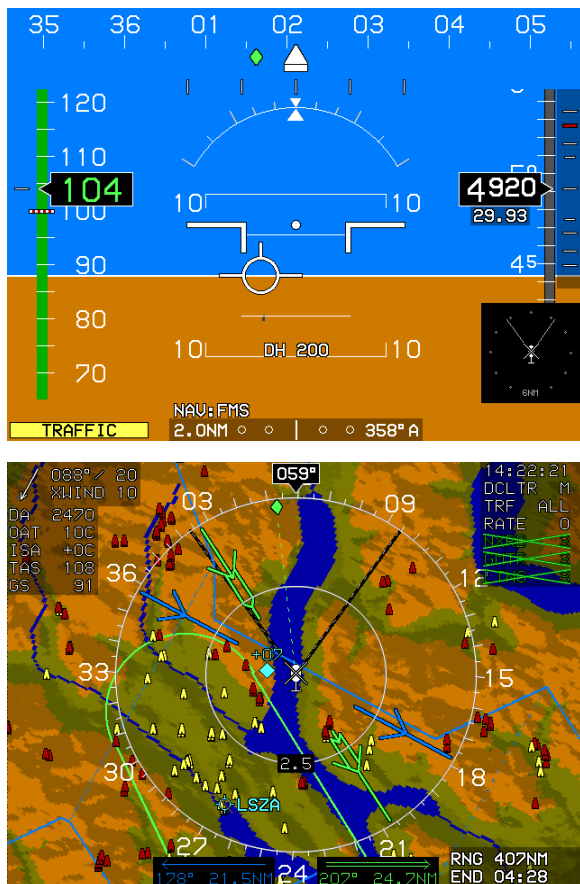


Figure 3-45: PFD with Terrain Deselected on PFD and Selected on MFD

Towers, antennas, and other obstructions such as buildings and manmade structures are shown on the PFD display as vertical amber (yellow) lines. Obstructions are conformal in both location and size and only shown in conjunction with terrain regardless of altitude. Obstructions representing a collision hazard are

annunciated aurally and with a caution or warning flag. Obstructions causing TAWS alarm are depicted as a flashing amber and red triangle. All vertical amber (yellow) lines in the Figure 3-46 are obstructions.



Audible Annunciation

Towers, antennas, and obstructions representing a collision hazard cause an annunciation of “Obstruction” and aural annunciation of “Caution Obstruction, Caution Obstruction” or “Warning Obstruction, Warning Obstruction”.

NOTE:

The obstruction data is provided by Jeppesen and must be updated each 28 days to maintain current database information.



Obstructions without Hazardous Condition



Obstructions Creating an OBSTRUCTION Warning

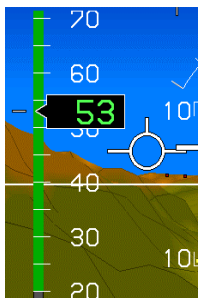
Figure 3-46: PFD with Obstructions

3.4.18. Flight Path Marker (Velocity Vector)

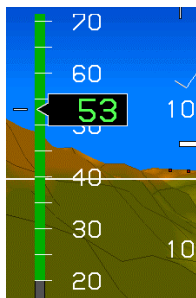


Figure 3-47: Flight Path Marker

The flight path marker appears at a location on the background to coincide with the aircraft's actual flight path as projected upon the outside world and is referenced to the Large Aircraft Symbol Reference Marks. The Reference Marks are centered on the display and laterally displaced parallel to the horizon with respect to the center of the display to account for the difference between aircraft track and heading and are vertically displaced perpendicular to the horizon to account for aircraft climb or descent angle. Because the flight path marker is used in conjunction with a three-dimensional background, the flight path marker utility normally associated with a HUD is achieved. When the location of the flight path marker is displaced to the extent it would interfere with heading, altitude, or airspeed indications, it is removed from the display as seen in Figure 3-48 with increasing crosswind from the right side.



Flight Path Marker nearing
Airspeed tape due to strong
crosswind



Flight Path Marker removed
due to excessive crosswinds
from the right

Figure 3-48: Flight Path Marker Views



**Figure 3-49: Flight Path Marker absent (Unusual Attitude
Mode)**

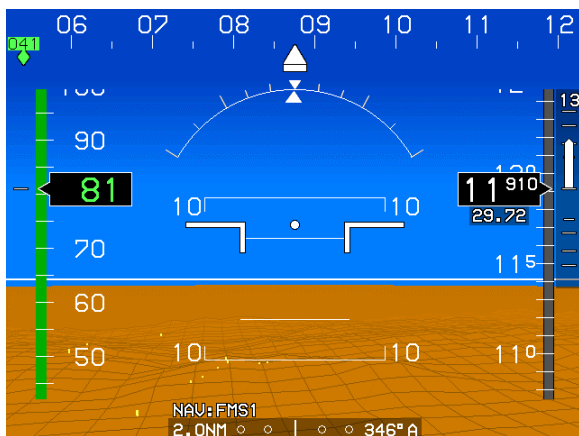


Figure 3-50: PFD with Flight Path Marker Removed

Flight path marker movement is dampened by reference to aircraft pitch and heading so not to deviate from pitch or heading at a rate greater than $1^\circ/\text{sec}$.

In Unusual Attitude Mode, the flight path marker disappears to allow the pilot to concentrate on the Large Aircraft Symbol Reference Marks for unusual attitude recovery. In reversionary mode 1 (GPS failure), the flight path marker changes to a light gray color after one minute to indicate degraded performance as seen below.

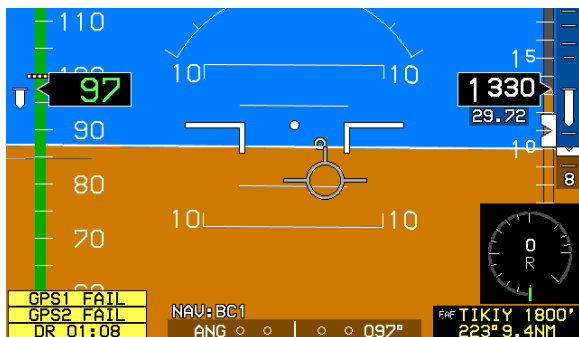


Figure 3-51: PFD with GPS Failure after 1 Minute

3.5. Hover Vector

Flight path marker is removed at low speed, <30 knots groundspeed, and replaced with hover vector symbology.



AGL Indicator (Normal)



AGL Indicator (Analog)



AW-109SP (Normal)



AW-109SP (Analog)

Figure 3-52: PFD Hover Vector Symbology

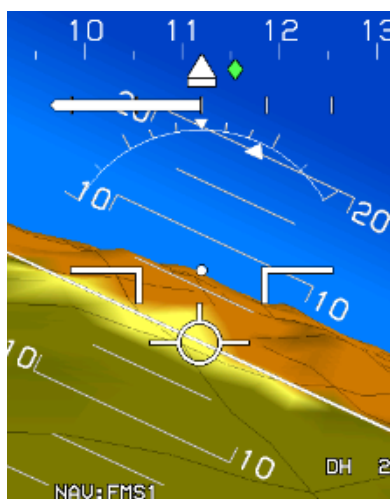
The hover vector indicates direction and groundspeed of drift at low groundspeeds (when lower than 30 IAS) consisting of Large Aircraft Symbol Reference Marks, an inner concentric ring indicating ten knots groundspeed, an outer concentric ring indicating 20 knots groundspeed, and a vertical and horizontal dashed line passing through the center extending to the outer ring. The white dot of the Large Aircraft Symbol Reference Marks indicates 0 knots groundspeed and is the center for the concentric rings. A gray dot equal in size to the white dot and connected to the white dot by a white line floats over the concentric ring area to indicate direction and magnitude of drift in a gods-eye view. Deviation of the dot in a straight up direction (12 o'clock position) indicates forward flight while straight down (6 o'clock position) indicates rearward flight. Deviation of the dot laterally indicates lateral drift in that direction.

The movement of the dot is constrained to less than five knots per second to prevent jumpiness. The example above shows drift, forward and slightly to the right (1 o'clock position) at 20 knots groundspeed. (See § 3.29.4 for full Hover Vector symbology with Hover page selected on MFD.)

NOTE:

In the event the bank scale was decluttered, it becomes uncluttered while at low speed <30 knots groundspeed.

3.6. Bank Angle Scale



The Bank Scale and Roll Pointer are centered upon the Large Aircraft Symbol Reference Marks in Basic or Unusual Attitude Modes.

Figure 3-53: Bank Angle

When bank angle scale decluttering is selected, a bank angle scale and sky pointer are displayed when the magnitude of bank angle exceeds 2.8°. With decluttering selected, appearance of the bank angle scale and roll pointer are dampened based upon magnitude and time to prevent nuisance appearances. When decluttering is not selected, the bank angle scale and sky pointer appear full time with level, 10°, 20°, 30°, 45°, and 60° marks on left and right sides. The bank angle scale and roll pointer are centered upon the Large Aircraft Symbol Reference Marks (Basic Mode or Unusual Attitude Mode).

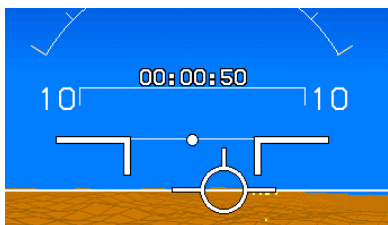
3.6.1. Turn Indication



Rate of turn is available as an option in the PFD Declutter menu to show a worm in the direction of turn with full scale deflection indicating a standard rate of turn and half standard rate indicated at the mid-scale marking.

Figure 3-54: Turn Indicator

3.7. Timer Indication



A countdown or count-up timer is displayed above the Fight Path Marker or Large Aircraft Symbol Reference Marks when selected by the pilot. The format of the time is “hh:mm:ss” (hours, minutes, seconds).

Figure 3-55: Timer

3.8. Marker Beacon Symbology

Marker beacons data acquired from the Navigation Receiver are displayed on the PFD and disabled when the selected NAV source is FMS.

Valid marker beacon signals cause circular indicators with appropriate coloring and markings to be displayed in the lower central portion of the PFD (shown in Figure 3-56).

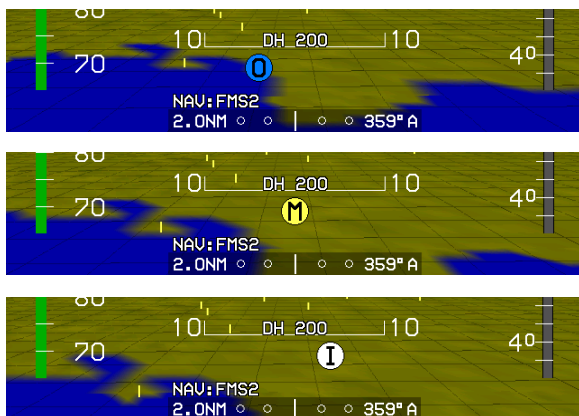


Figure 3-56: Marker Beacons

3.9. Flight Director Symbolology (FD1 Single Cue)

The Flight Director Symbolology is pilot-selectable through controls on the IDU or integrated autopilot/flight director equipment. When selected, Flight Director Symbolology and valid steering commands are received from the Flight Director with one of the following symbols shown in the Normal Mode.

The PFD has a waterline symbol fixed in the center of the display. Rotation of the background, pitch scale, and background oriented display elements occur relative to the location of the waterline symbol or Large Aircraft Reference Marks.

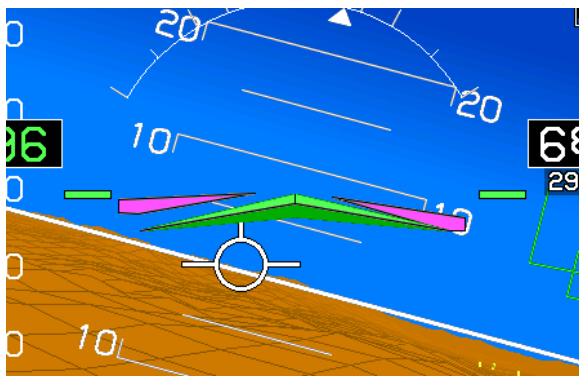


Figure 3-57: Rotorcraft Flight Director FD1 Single Cue

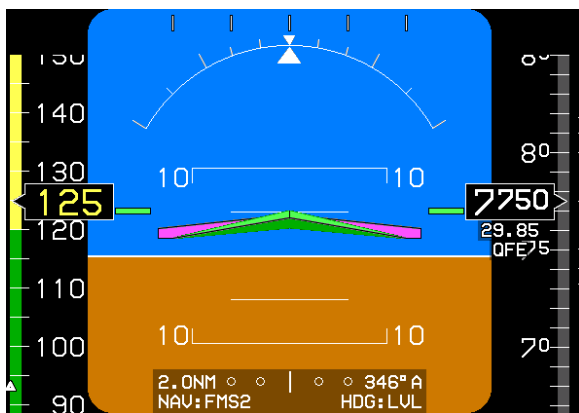


Figure 3-58: Rotorcraft Flight Director FD1 (Basic Mode)

3.9.1. Flight Director Symbology (FD2 Dual Cue)

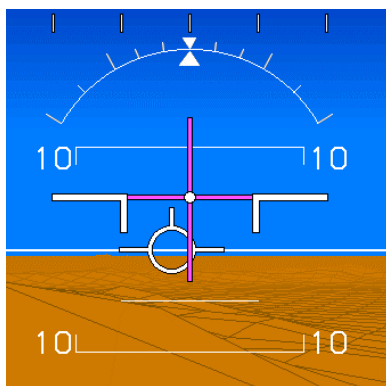


Figure 3-59: Flight Director FD2 (Normal Mode)

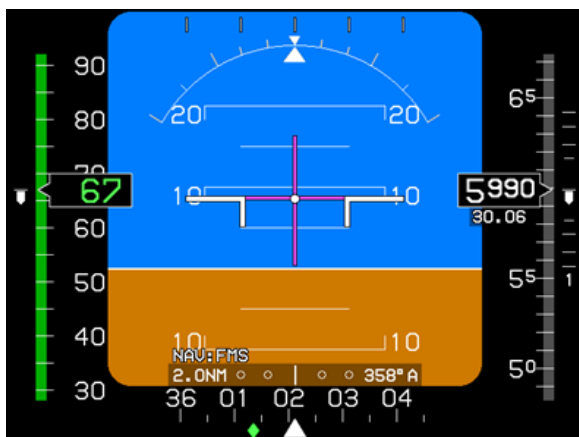


Figure 3-60: Flight Director FD2 (Basic Mode)

3.10. Landing Gear Indication

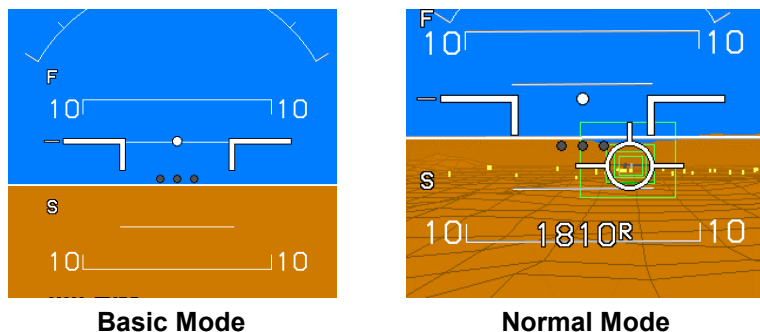


Figure 3-61: Landing Gear Indication

If configured, the PFD displays landing gear position as small “tires” below the Flight Path Marker Large Aircraft Symbol Reference Marks (rotorcraft and Basic Mode). The landing gear position display is driven by discrete inputs configured in the aircraft limits as landing gear discretizes.

3.11. Course Deviation Indicator



Figure 3-62: Course Deviation Indicator

The order of precedence of type accuracy used by the system from highest to lowest is as follows:

- 1) Manual RNP: The pilot may always override the automatic accuracy types by setting a Manual RNP value.
- 2) Automatic RNP: These are based upon RNP values which are coded in the navigation database. The EFIS looks at the leg coding on all legs other than those on the Final Approach Segment. On the Final Approach Segment, the EFIS looks at the “Level of Service” record for those approaches which have RNP transition legs, and then goes to LP or LPV minima for the Final Approach.
- 3) Default TSO-C146C Operation: Operation as specified as per the Table 3-9 for enroute, terminal, and various approach modes according to the “Level of Service” record.

NOTE:

When outside the approach region of operation and neither a manually entered nor automatic RNP value exists, system operation defaults to GPS/SBAS operation as specified in RTCA/DO-229D.

Table 3-9: CDI Behavior and Color

CDI Pointer and condition	Color or behavior
Full Scale deflection	FLASH
When Slaved to GPS/SBAS	<p>Scale is appropriate FSD value for mode of flight:</p> <p>Enroute: ± 2 NM</p> <p>From Enroute to Terminal: Change from ± 2 NM FSD to ± 1 NM FSD over distance of 1 NM; start transition when entering terminal mode.</p> <p>From Terminal to Enroute: Change from ± 1 NM FSD to ± 2 NM FSD over distance of 1 NM; start transition when entering enroute mode.</p> <p>From Terminal to Approach: If VTF, switch immediately. Otherwise, change from ± 1 NM FSD to approach FSD over distance of 2 NM; start transition at 2 NM from FAWP.</p> <p>From Approach to Terminal: Change to ± 1 NM.</p> <p>From Departure to Terminal: If initial leg is aligned with runway, change from ± 0.3 NM FSD to ± 1 NM FSD at the turn initiation point of the first fix in the departure procedure.</p>
When Slaved to GPS/SBAS (with GPS Loss of Navigation)	Amber (Yellow)
Normal Conditions	Magenta
In sources other than FMS	Angular scale annunciation
Navigation source is Localizer (Course error exceeds 105°)	Reverse sensing
When lateral deviations are in a failed state	Red "X" displayed over CDI

3.12. Course Deviation Indicator (AW-109SP)

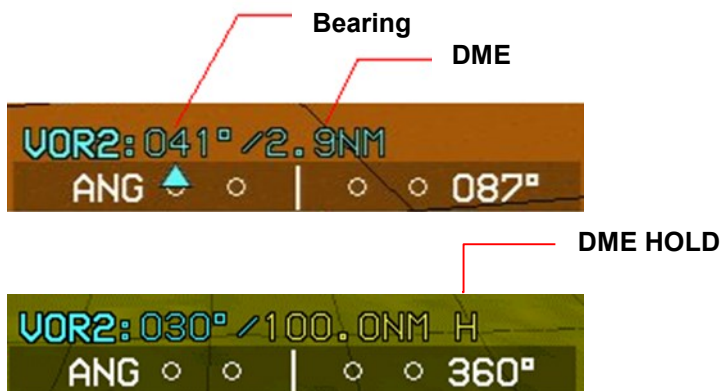


Figure 3-63: Course Deviation Indicator (AW-109SP)

The Course Deviation Indicator displays the course deviation for the currently selected Primary NAV Source. The Primary NAV Source drives the indicated course deviation and is annunciated just above the CDI scale. Annunciation is either **FMS**, **FMS1**, **FMS2**, **VOR1**, **LOC1**, **BC1**, **VOR2**, **LOC2**, or **BC2** (“BC” is annunciated instead of “LOC” when course error exceeds 105°). For VOR, the bearing and DME are annunciated next to the primary NAV source above the CDI. For LOC or BC, the DME is annunciated next to the primary NAV source above the CDI. If a DME channel is in hold mode, the associated distance readout is displayed in amber (yellow), and the letter “H” is shown to the right of the distance readout. The Course Deviation Indicator is displayed when a MOT flight pattern is being displayed.

Table 3-10: AW-109SP Lateral Navigation Color Logic

Type of Indicator	Color	Notes
Primary source FMS1 Or FMS2	Amber (Yellow)	During Loss of Navigation Caution
Side in Command and Side Not in Command	Magenta	If FMS1 or FMS2 and either the AFCS engaged, lateral Nav Mode is NAV, and the EFIS is in LNAV mode, or the AFCS engaged lateral Nav Mode is NLOC.
Primary source is not FMS (VLOC1 or VLOC2)	Magenta	The AFCS engaged lateral navigation mode is VOR, LOC, TCN, VAPP, or BC
	Cyan	All other cases

3.12.1. OBS Setting of CDI

In automatic mode, the system automatically controls the scale and OBS setting according to the requirements of GPS/SBAS (TSO-C-146C). The currently selected navigation source is annunciated immediately below the CDI as follows:

- | | |
|---|---|
| 1) NAV: FMS1 | 6) NAV: VOR2 |
| 2) NAV: FMS2 | 7) NAV: LOC2 |
| 3) NAV: VOR1 | 8) NAV: BC2 (annunciated
instead of LOC2 when
course error exceeds 105°) |
| 4) NAV: LOC1 | |
| 5) NAV: BC1 (annunciated
instead of LOC1 when
course error exceeds 105°) | |

3.12.2. Heading/Roll-Steering Sub-Mode

The heading/roll-steering sub-mode annunciation appears immediately to the right of the selected navigation source annunciation and displays either:

- 1) HDG: **LVL** (Wing-Leveling Sub-Mode Guidance)
- 2) HDG: **LNAV** (LNAV Sub-Mode Guidance)

- 3) HDG: **BUG** (Heading Bug Sub-Mode Guidance)
- 4) HDG: --- (Failure Sub-Mode)

3.13. No Autopilot or Fully-Integrated Autopilot Course Deviation Indicator



Figure 3-64: Course Deviation Indicator No Autopilot or Fully-Integrated Autopilot

In an installation without an autopilot or with a fully-integrated autopilot (e.g., HeliSAS-E), the heading/roll-steering sub-mode annunciation is not meaningful and should be decluttered from the CDI display. Therefore, the shaded background of the CDI only falls behind the CDI scale. An abbreviated navigation source annunciation (without “NAV:”) appears above the top left corner of the CDI scale. The heading/roll-steering sub-mode annunciation does not appear, as it is not required with autopilot mode annunciations or when an installation does not include an autopilot.

3.13.1. Vertical Deviation Indicator

The PFD has a vertical deviation indicator on the right side to display vertical deviation for the currently selected vertical navigation source for displaying descent profile. When the selected vertical navigation source is FMS, the vertical deviation indicator conforms to the vertical deviation display requirements of the GPS/SBAS requirements. The vertical deviation indicator only appears when the source of vertical navigation is valid. When the source of vertical navigation is FMS (either LPV or VNAV modes), the source is valid if on VNAV descent segments when approaching the Top of Descent point to provide descent anticipation as long as the following are true:

- 1) The aircraft is within 2NM or twice the full scale deflection for the mode of flight (whichever is greater) of the lateral navigation route; AND

- 2) The aircraft is in TO operation relative to the active VNAV waypoint (i.e., taking into account VNAV offsets); AND
- 3) If on the final approach segment, the aircraft is within a 35° lateral wedge of the azimuth reference point (the GARP or MAWPT + 10,000 ft.).

Table 3-11: Vertical Deviation Indicator Behavior

Source (Below the VDI)	Behavior/Condition	Pointer Color
FMS	Conforms to the VDI display	Magenta
Glideslope	The source must be valid when a valid glideslope is received.	Magenta
LPV or VNAV mode	<p>Source is valid if:</p> <p>On VNAV descent segments when approaching the Top of Descent point so as to provide descent anticipation as long as the following are true:</p> <ol style="list-style-type: none"> 1) On VNAV descent segments; OR 2) If the vertical deviations on VNAV level segments option is enabled, on VNAV level segments; OR 3) If the vertical deviations on VNAV level segments option is disabled, when approaching the Top of Descent point to provide descent anticipation; <p>Providing:</p> <ol style="list-style-type: none"> 1) The aircraft is within 2NM or twice the full scale deflection for the mode of flight (whichever is 	Magenta

Table 3-11: Vertical Deviation Indicator Behavior		
Source (Below the VDI)	Behavior/Condition	Pointer Color
	greater) of the lateral navigation route; AND 2) The aircraft is in TO operation relative to the active VNAV waypoint (i.e., taking into account VNAV offsets); AND 3) If on the final approach segment, the aircraft is within a 35° lateral wedge of the azimuth reference point (either the GARP or MAWPT + 10,000 ft.).	
LPV,VNV-G	During GPS Loss of Navigation or GPS Vertical Loss of Navigation	Pointer and Text Color Amber (Yellow)

Vertical deviation indicator disappears in Unusual Attitude Mode.

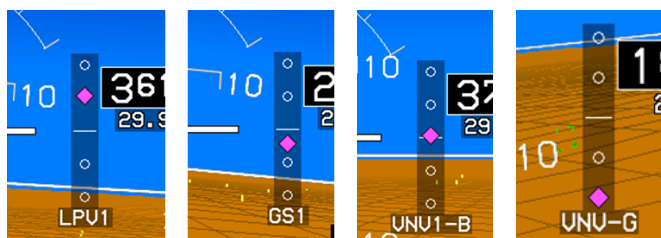


Figure 3-65: Vertical Deviation Indicator

- 1) **LPV1**: When descending on the final approach segment in LPV mode.
- 2) **LPV2**: When descending on the final approach segment in LPV mode.

- 3) **VNV1-G**: When descending on the final approach segment in LP, LNAV/VNAV, and LNAV or RNP modes when using GPS VNAV.
- 4) **VNV2-G**: When descending on the final approach segment in LP, LNAV/VNAV, and LNAV or RNP modes when using GPS VNAV.
- 5) **VNV1-B**: Default FMS barometric VNAV mode.
- 6) **VNV2-B**: Default FMS barometric VNAV mode.
- 7) **GS1**: Glideslope receiver #1
- 8) **GS2**: Glideslope receiver #2

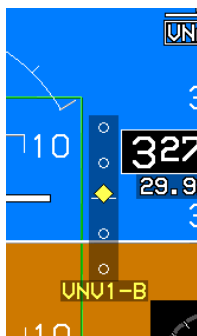


Figure 3-66: Vertical Deviation Indicator Color during GPS/SBAS LON or VLON

3.13.2. Vertical Deviation Indicator (AW-109SP)



The color of the Vertical Deviation Indicator is determined using Table 3-12.

The Vertical Deviation Indicator is not displayed when a MOT flight pattern is being displayed.

Figure 3-67: Vertical Deviation Indicator Color (AW-109SP)

Table 3-12: AW-109SP Vertical Deviation Color Logic

Type of indicator	Color	Notes
Primary source FMS1 or FMS2	Amber (Yellow)	During Loss of Navigation Caution
Side in Command and Side Not in Command	Magenta	1) If FMS1 or FMS2 and either the AFCS engaged vertical Nav Mode is VNAV and the EFIS is in VNAV Submode tracking the VNAV descent control law; or 2) The AFCS engaged vertical navigation mode is NGS; or 3) The AFCS engaged vertical navigation mode is NGA
	Cyan	In all other cases from above
Vertical Deviation Indicator	Magenta	The Vertical Deviation Color for the side not in command is magenta if the Primary Navigation source of the Side not in Command is same as the Primary Navigation Source of the Side in Command and the AFCS engaged vertical navigation mode is GS.
	Cyan	All other cases

3.13.3. Vertical Deviation Indicator (EFIS Coupled)



Figure 3-68: EFIS Coupled Vertically with Glideslope Mode Engaged

When vertically integrated with an autopilot (either fully integrated or partially integrated) through use of the glideslope mode discrete input with the glideslope mode engaged, the selected vertical navigation source is green indicating the autopilot is vertically coupled to the selected vertical navigation source. Otherwise, the selected vertical navigation source is white.

3.13.4. Highway in the Sky/Skyway

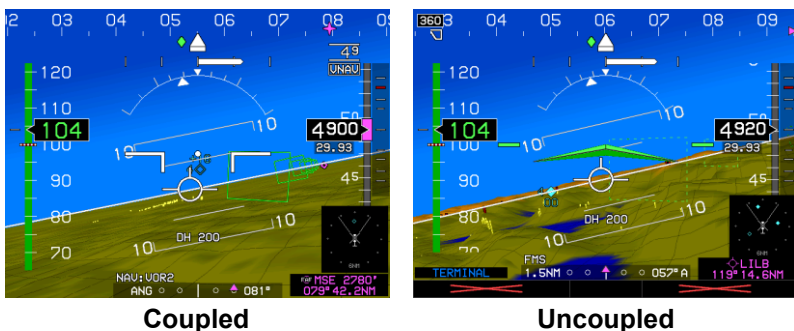


Figure 3-69: Highway in the Sky

3.13.5. Highway in the Sky (AW-109SP)

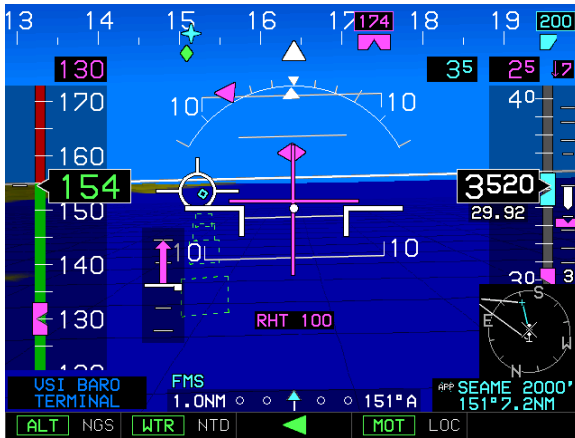


Figure 3-70: Highway in the Sky (AW-109SP)

The Highway in the Sky boxes are drawn dashed if the autopilot is not coupled to the displayed flight plan (either FMS or MOT). Coupling is indicated using the same logic as lateral navigation.

3.13.6. Active Waypoint and Waypoint Identifier

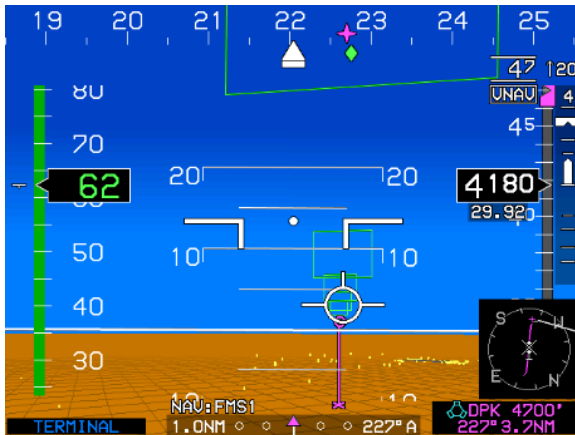
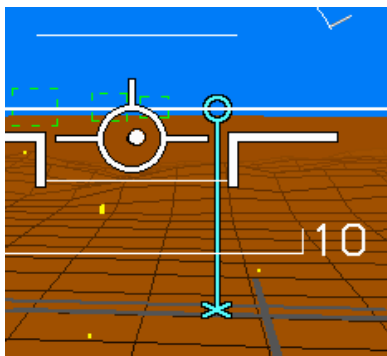


Figure 3-71: Active Waypoint



The color of the active waypoint symbol is determined using the Lateral Navigation Color Logic on Table 3-10.

Figure 3-72: Active Waypoint (AW-109SP)

The PFD displays the active waypoint symbol as a magenta “tethered balloon” consisting of an “X” depicted at the ground location of the active waypoint, a hoop or “tethered balloon” (fly-over waypoints) or “tethered diamond” (fly-by waypoints) depicted at the VNAV altitude or at aircraft altitude (if there is no VNAV altitude), and a line connecting the “X” and the hoop. The “X” and the connecting line are not shown if no ground elevation information is encoded with the NavData waypoint information (e.g., terminal and enroute fixes). The active waypoint symbol is drawn using the hidden surface removal techniques of the terrain and obstruction rendering so an active waypoint behind terrain appears to be so. The active waypoint symbol disappears in Unusual Attitude Mode and turns amber (yellow) in the event of GPS Loss of Navigation caution.

The identifier of the waypoint along with the bearing and distance to the waypoint is displayed in the lower right corner of the PFD in magenta. If a target altitude is not set and the active waypoint has a VNAV altitude associated as the example above, the identifier includes a display of the VNAV altitude.

NOTE:

Only the active waypoint is shown on the PFD display. Subsequent waypoints in a route are displayed sequentially as the current active waypoint is passed.

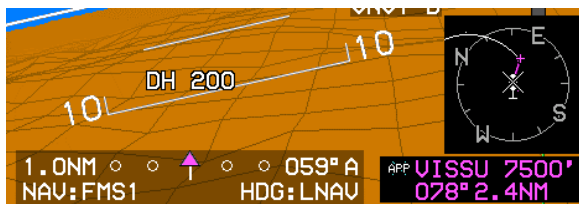
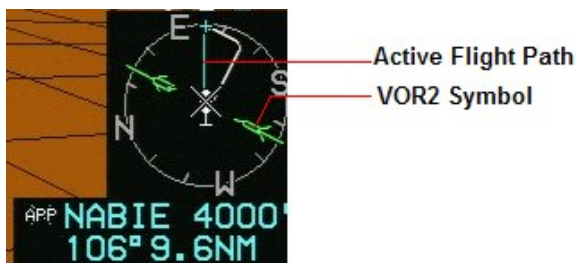
With terrain turned off, the active waypoint is always visible regardless of distance.

NOTE:

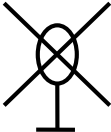
If the active waypoint is beyond the lateral limits of the screen, the magenta waypoint direction pointer (i.e., the magenta triangle) on the directional scale indicates the shortest direction of turn to the waypoint.

If the waypoint is only a hoop hanging in space, it is a fix and not directly associated with a NAVAID on the ground (such as a VOR, NDB, user waypoint, or airport).

If the waypoint X disappears behind terrain on the PFD display, there is terrain between the aircraft present position and the waypoint.

3.13.7. Mini Map

Figure 3-73: Mini Map
3.13.8. Mini Map and Active Waypoint Information Block (AW-109SP)

Figure 3-74: Mini Map and Active Waypoint Information Block (AW-109SP)

The color of the active leg of the navigation route and the active waypoint on the mini-map is determined using Table 3-10.

Table 3-13: Mini-Map Behavior (When not Decluttered)		
VOR Pointer, Active Leg Ownship Symbol	Color	Condition
VOR 1	Blue	When Valid
VOR 2	Green	When Valid
Active Leg (GPS/SBAS normal)	Magenta	
Active Leg (GPS/SBAS LON condition)	Amber (Yellow)	
<p>Rotorcraft</p>  <p>Ownship symbol</p>	White	
Mutually exclusive with the Analog AGL Indicator		
Mini-Map disappears in Unusual Attitude Mode		
Mutually exclusive with Traffic Thumbnail		



Blue VOR #1



Green VOR #2

Figure 3-75: Mini Map VOR Symbology

3.13.9. Traffic Thumbnail



When selected from declutter options, the traffic thumbnail has clock face markings normally fixed at the 6 NM scale. In the event of a traffic warning (TA or RA), the traffic thumbnail is automatically enabled, while the traffic warning is active, and the aircraft is above 500' AGL.

During a traffic warning, the traffic thumbnail scale automatically adjusts in multiples of two NM (2 NM, 4NM, or 6NM), to optimally display the traffic. While the traffic thumbnail is mutually exclusive with the Mini-map, it too disappears in the Unusual Attitude Mode.

Figure 3-76: Traffic Thumbnail

3.13.10. Traffic Display Definitions

- 1) Resolution Advisory (**RA**): Traffic with a dangerous closest point of approach and generates climb or descent commands as defined by internal TCAS-II sensor logic.
- 2) Traffic Advisory (**TA**): Traffic with a dangerous closest point of approach as defined by internal traffic sensor logic.
- 3) Proximate Advisory (**PA**): Traffic within 6 NM and ± 1200 feet from ownship that is not an RA or TA.
- 4) Other Traffic (**OT**): Traffic beyond 6 NM or ± 1200 feet from ownship that is not an RA or TA.





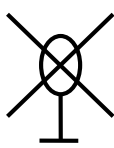
3.13.11. Traffic Rendering Rules

Traffic thumbnail and PFD traffic are rendered as follows.

Table 3-14: Traffic Rendering Rules

Type Traffic	Distance	Results
OT and PA Traffic	Beyond 6 NM	Not displayed

TCAS-I, TCAS-II, TAS or TIS-A Sensor	Within 200' of ground	Not Displayed
Table 3-15: Pilot Selected OT and PA Traffic Altitude-Filter		
Mode	Parameter	
AUTO	If aircraft VSI is less than -500FPM, traffic within +2,700 and -9,900 feet of aircraft altitude is displayed. If aircraft VSI is more than +500FPM, traffic within -2,700 and +9,900 feet of aircraft altitude is displayed. Otherwise, traffic within -2,700 and +2,700 feet of aircraft altitude is displayed.	
ABOVE	Traffic within -2,700 and +9,900 feet of aircraft altitude is displayed.	
BELOW	Traffic within +2,700 and -9,900 feet of aircraft altitude is displayed.	
NORMAL	Traffic within -2,700 and +2,700 feet of aircraft altitude is displayed.	
ALL	All received traffic is displayed, no altitude filtering is performed.	

Table 3-16: Traffic Symbology	
Type Traffic	Symbology
TCAS-I, TCAS-II and TIS-A	 Other Traffic  Proximate Advisory  Traffic Advisory (Flashing)  Resolution Advisory (Flashing)
Ownship symbol	Rotorcraft 

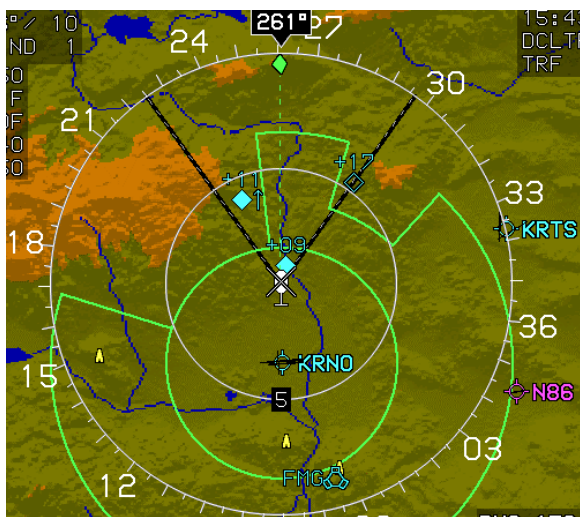
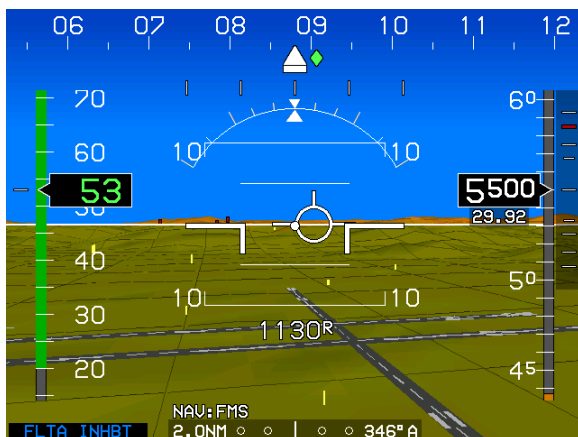


Figure 3-77: Traffic Symbology

3.13.12. Runways

The PFD displays airport runways in a three-dimensional manner. Upon activation of a DP, VFR approach, IFR approach, or STAR procedure, the runways for the airport associated with the procedure are also displayed. In addition, the runways associated with the three nearest airports (as computed by the TAWS algorithms) are displayed. The runways are displayed using the hidden surface removal techniques of the terrain and obstruction rendering, so runways behind terrain appear to be so. Runways are shown in dark gray according to characteristics contained in the navigation database, including elevation, position, orientation, length, and width. The landing portion of the selected runway, taking into account displaced threshold data, is shown in light gray.



Runways (Other Rotorcraft)






Runways (AW-109SP)

Figure 3-78: Runways

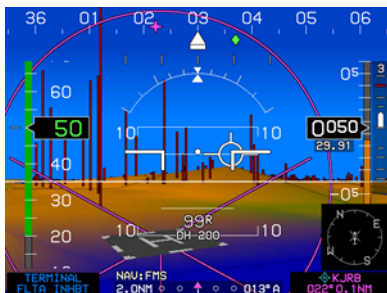
When the depiction of a runway is wide enough, runway markings, including aiming point markings, centerline, designation, and displaced threshold arrows, are shown as follows.

Table 3-17: Runway Drawing Criteria

Feature	Color	Notes
Runway markings, aiming point markings, centerline, designation, and displaced threshold arrows	Dark gray 	According to characteristics from navigation database, e.g., including position, orientation, length, and width.
Runway markings	Medium gray 	
Landing portion of the selected runway.	Light gray 	Taking into account displaced threshold data.
Runway markings for the selected runway	Lighter gray than the light gray.	

3.13.13. Heliports

Heliports appear as distinguishable 150' X150' helipads with applicable markings as shown below.



Helicopter (Other Rotorcraft)



Helicopter (AW-109SP)

Figure 3-79: Helipads

3.13.14. AFCS Annunciations (AW-109SP)



Figure 3-80: AFCS Annunciations (AW-109SP)

The Collective, Longitudinal (pitch), and Lateral (roll) Engaged Annunciations are shown, in that order, with a black background at the bottom of the display. The current PFD symbology is adjusted to make room at the bottom of the display for these annunciations. To the right of each, the Collective, Lateral, and Longitudinal Armed Annunciations are displayed as shown in Figure 3-81.

When commanded by the AFCS, each engaged annunciation is displayed within an unfilled box. The box is either flashing green or amber (yellow). A green box has a 1Hz flashing 60% duty cycle for

five seconds after AFCS request then off. An amber (yellow) box has a 1Hz flashing 60% duty cycle for five seconds after AFCS request then steady on as long as the request is maintained by AFCS.

When commanded by the AFCS, excessive deviation is indicated with a flashing amber (yellow) chevron displayed on either side of the annunciation box. The amber (yellow) chevron has a 1Hz flashing 60% duty cycle (0.6 seconds on and 0.4 seconds off).

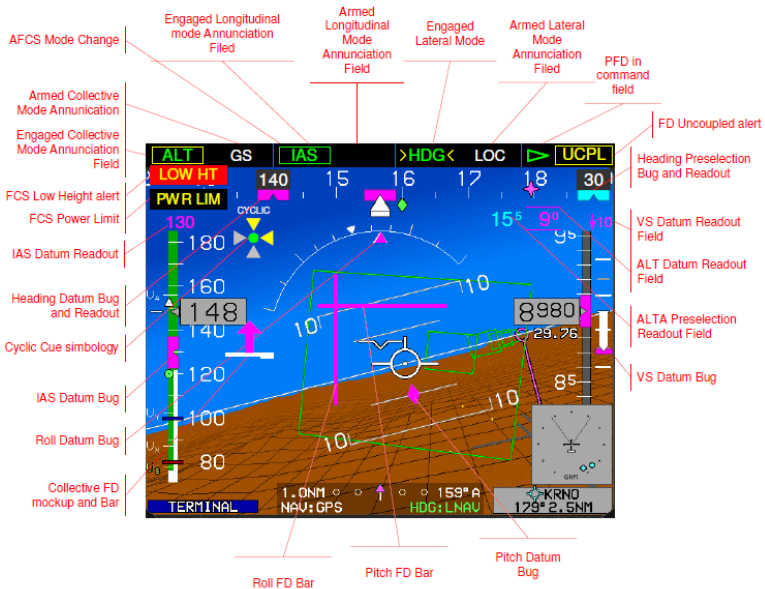


Figure 3-81: PFD Symbology (AW-109SP)

3.13.15. PFD in Command Arrow (AW-109SP)

The PFD in Command arrow is a filled-green triangle in the middle of the autopilot annunciation bar pointing to the PFD in command of the AFCS.

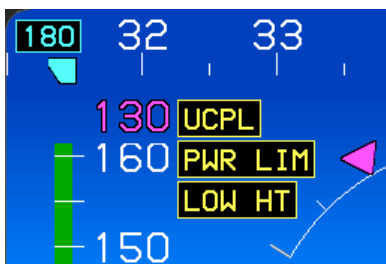
3.13.16. FMS LNAV and FMS VNAV Submode Annunciations (AW-109SP)

FMS LNAV and FMS VNAV Submode Annunciations are in the right-most portion of the autopilot annunciation bar. The Submode Annunciations are displayed in magenta. If the LNAV Submode is

armed, the LNAV Submode annunciation is displayed in white. The following tables describe the possible annunciations.

Table 3-18: (AW-109SP) FMS LNAV and FMS VNAV Submode Annunciations	
LNAV Annunciation	Meaning
----	LNAV Submode Failure Warning
HDG	Heading Submode Engaged
LNAV in white color	Heading Submode Engaged and LNAV Submode Armed
LNAV	LNAV Submode Engaged
VNAV Annunciation	Meaning
---	VNAV Submode Failure Warning
ALTA	Altitude Acquire Submode Engaged
VNAV	VNAV Submode Engaged

3.13.17. AFCS Caution Alert Messages (AW-109SP)



Order of precedence for AFCS Caution Alert Messages:

- 1) UCPL
- 2) PWR
- 3) PIM
- 4) LOW HT

Figure 3-82: AFCS Caution Alert Messages (AW-109SP)

3.13.18. Link Fail Message (AW-109SP)



If no AFCS labels are present on either AFCS channel for one second, the EFIS displays a "LINK FAIL" Alert.

Figure 3-83: Link Fail Message (AW-109SP)

3.13.19. Cyclic Cue (AW-109SP)



If commanded and controlled by the AFCS, the Cyclic Cue is displayed in the upper left of the PFD. The center circle is either gray or green as commanded by the AFCS. The outer triangles are either gray or amber (yellow) as commanded by the AFCS.

Figure 3-84: Cyclic Cue (AW-109SP)

3.13.20. Collective Cue and Symbol (AW-109SP)

The Collective Cue and Symbol indicate collective position and collective steering. The Collective scale consists of five white tick marks over a shaded background. The distance between tick marks represents a 25% change in value. The Collective Symbol is white. The Collective Symbol input has a range of 0% (bottom of the scale) to 100% (top of the scale).



The Collective Cue input has a range of -100% to +100%. The Collective Cue originates from the Collective Symbol and points upward to the extent of the value for positive values or points downward to the extent of the value for negative values. Maximum Collective Cue deflection is limited by the range of the scale. At Collective Cue values between -1 and +1 (i.e., no change in collective position being commanded), double arrows are displayed, one above the Collective Symbol and one below.

Figure 3-85: Collective Cue and Symbol (AW-109SP)

3.13.21. Horizon Synchronization (AW-109SP)

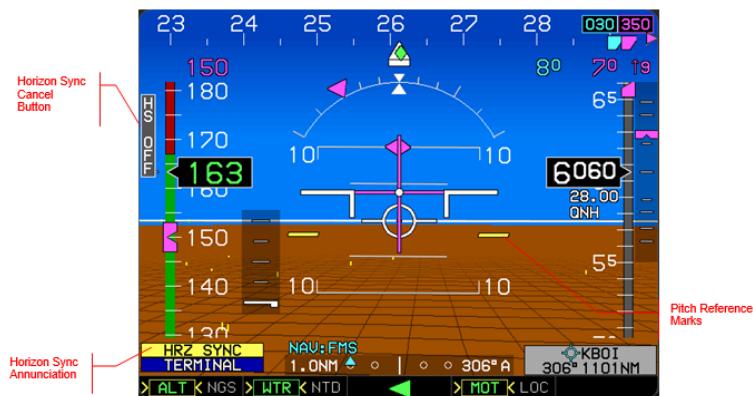


Figure 3-86: Horizon Synchronization (AW-109SP)

Horizon Synchronization functionality allows re-centering of the horizon during Cat A departures. When activated, it introduces an offset to pitch angle and is available for activation when all of the following conditions are met:

- 1) Cat A is enabled (airspeed < 60 KIAS);
- 2) Pitch attitude is valid;
- 3) No Pitch or Roll Mismatch Alert exists;
- 4) Pitch is in the range of $\pm 11^\circ$; and
- 5) EFIS system is not in unusual attitude mode.

When Horizon Synchronization is activated (engaged), it remains activated when pitch is greater than $\pm 11^\circ$ and less than or equal to $\pm 30^\circ$. Horizon Synchronization is deactivated when any of the following is true:

- 1) Pitch attitude information is invalid;
- 2) Pitch and Roll mismatch Alert exists;
- 3) Pitch is greater than $\pm 30^\circ$;
- 4) EFIS system is in unusual attitude mode.

When Horizon Synchronization is activated, the horizon line is re-centered and two amber (yellow) reference marks are displayed at the actual horizon position. If Horizon Synchronization is manually or automatically deactivated, Horizon Synchronization mode is deactivated and the PFD and/or MFD displays return to normal.

3.13.22. Decision Height and Radar Height Readout (AW-109SP)



The Radar Height Readout is displayed on the PFD AGL Altitude Indication page beneath the AGL value and DH readout (if available). The Radar Height readout is magenta text “RHT” followed by magenta numerical text indicating the value of the Radar Height Bug. To enhance night visibility, the background of the

the Decision Height and Radar Height Readouts is blacked-out.

Figure 3-87: Decision Height and Radar Height Readout (AW-109SP)

3.14. MFD Screen requirements (AW-109SP)

3.14.1. ND SCREEN



Figure 3-88: ND Screen (AW-109SP)

3.14.2. Compass Rose Symbols (AW-109SP)

The Compass Rose has a Heading Datum Bug and a Heading Preselect Bug shaped to geometrically interact with the present heading pointer symbol. The Heading Datum Bug is filled-magenta, and the Heading Preselect Bug is filled-cyan. When the two bugs overlap, the Heading Datum Bug is drawn on top of the Heading Preselect Bug.

3.14.3. HSI Overlay (AW-109SP)

The HSI Overlay also includes a NAV Preview display and when selected, the HSI overlay displays a NAV Preview Pointer indicating the NAV Preview selected course, deviation, and TO/FROM in a standard HSI format. The NAV Preview Pointer is a dashed cyan line to differentiate it from the Primary NAV Pointer. When the AFCS armed mode indicates BC, LOC, VAPP, TCN, or VOR, the NAV Preview pointer flashes with a 1Hz 60% duty cycle. This indicates the AFCS is about to switch from NAV mode to the armed mode and, upon switching, the armed mode uses the NAV Preview source as its Primary NAV source. The NAV Preview Pointer TO/FROM indicator is a solid white triangle. There is no deviation scale associated with the NAV Preview Pointer to avoid confusion with the Primary NAV Pointer deviation scale. NAV Preview source indication and OBS setting are displayed in the top center portion of the HSI overlay and are the same color as the NAV Preview Pointer.

3.14.4. Active Leg of Active Flight Plan Path/Active Waypoint/Manual Course (AW-109SP)

The color of the active leg in the flight plan path, active waypoint, and manual course line are determined using Table 3-10.

NOTE:

When a MOT flight pattern is displayed, the active leg includes all legs between the “From” and “To” waypoints.

3.14.5. Identifier, Bearing, Distance and Time to Active Waypoint (AW-109SP)



The color for rendering the identifier, bearing, distance, and time to the active waypoint is determined using Table 3-10.

Figure 3-89: Identifier, Bearing, Distance and Time to Active Waypoint (AW-109SP)

NOTE:

When a MOT flight pattern is being displayed, these values are derived from the AFCS.

3.14.6. Swiss Grid (AW-109SP)

The Swiss Grid is a geographic coordinate system common in Switzerland and uses the geodetic datum CH1903. The pilot may select Swiss Grid Mode. If Swiss Grid Mode is active, all displayed location parameters are converted from WGS 84 latitude, longitude, and MSL altitude to Swiss Grid X, Y, and Z for display.

CAUTION:

Swiss Grid should not be used outside of Switzerland.



Swiss Grid Coordinates

Figure 3-90: Swiss Grid (AW-109SP)

When in Swiss Grid Mode, NavData information boxes display Swiss Grid Coordinates X, Y, and Z parameters instead of latitude and longitude. The display of elevation in feet MSL at the top of the NavData information box is retained regardless of mode.

3.15. Navigation Display Symbology

Navigation Display is presented in a variety of formats, including:

- | | |
|---------------------|-------------|
| 1) Moving Map | 5) Traffic |
| 2) Conventional HSI | 6) Datalink |
| 3) Navigation Log | 7) WX RDR |
| 4) Strikes | 8) Video |

3.15.1. Basic Moving Map



(Other Rotorcraft)



(AW-109SP)

Figure 3-91: Basic Moving Map

NOTE:

When selected, Latitude/Longitude is displayed below the ownship symbol.

3.15.2. Ownship Symbology



Rotorcraft



Pan Mode

Figure 3-92: Ownship Symbology

3.15.3. Compass Rose/ND Boundary Circle Symbol



In the Heading Up mode, the magnetic digital heading readout and pointer are aligned with the longitudinal axis of the ownship symbol.

Figure 3-93: Compass Rose/ND Boundary Circle Symbol

3.15.4. Moving Map with Instrument Approach



Figure 3-94: Moving Map with Instrument Approach

3.15.5. North-Up Arc Mode



Figure 3-95: North-Up Arc Mode

3.15.6. North-Up Centered Mode



Figure 3-96: North-Up Centered Mode

3.15.7. Heading-Up Centered Mode



Figure 3-97: Heading-Up Centered Mode

3.15.8. Air Data and Groundspeed

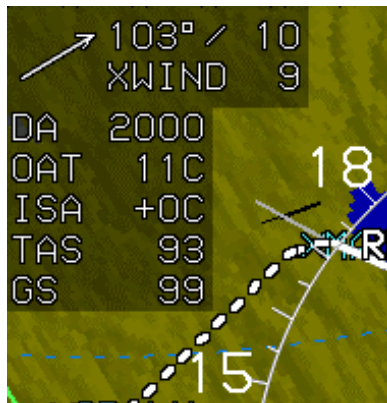


Figure 3-98: ND Air Data and Groundspeed

The following data items are displayed in the upper left corner of the ND as seen above:

- 1) **Wind:** Consists of a direction readout in degrees, speed readout, crosswind component readout in knots, and graphical

wind vector arrow oriented to correspond to the ND orientation. Wind information is not shown when indicated airspeed is in the noise range (less than 20 KIAS), or when the aircraft is in Ground Mode.

- 2) **Outside Air Temperature:** Displayed digitally in degrees C or F by the Temp Units flag.
- 3) **International Standard Atmosphere:** The difference between International Standard Atmosphere (ISA) temperature and current outside air temperature is displayed digitally in degrees C or F with a negative value meaning outside air temperature is less than standard.
- 4) **Density Altitude:** Displayed digitally in feet.
- 5) **True Airspeed:** Displayed digitally in knots.
- 6) **Groundspeed:** Displayed digitally in knots.

3.16. Conventional HSI/PTR Format



Figure 3-99: Conventional HSI/PTR Format

When the HSI screen is selected, the same ownship symbolology is used as described for the ND, and the compass rose is always aligned with Magnetic North. When the HSI NAV source fails, a red "X" is displayed in place of the HSI deviations.

As seen in Figure 3-100, a green diamond-shaped track pointer appears on the compass rose and is aligned with the aircraft's track across the earth at groundspeeds greater than 30 Kts.

Conventional symbology is displayed on the HSI, including a selected course needle, lateral deviation indicator, and "TO-FROM" indicator. When slaved to GPS/SBAS and a GPS Loss of Navigation condition exists, the HSI pointer becomes amber (yellow) otherwise it remains magenta.

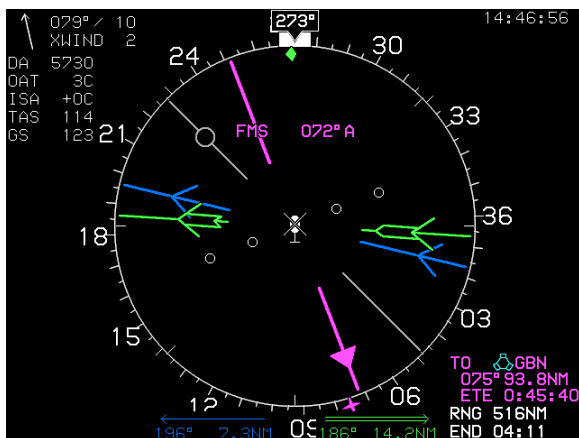


Figure 3-100: Conventional HSI/PTR Format; HSI with VDI and Glideslope

When selected, the VOR1, VOR2, and ADF navigation are displayed as seen in Figure 3-100 with the magenta single line FMS1 showing a Course of 072°, a blue single line VOR1 needle showing 196° and 7.3 DME to the station and a green double line VOR2 needle showing a bearing of 186° and 14.2 DME to the station. The ADF is tuned to a NDB with a bearing of 228° to the station. When the signal is invalid, the associated pointer is not shown.



Figure 3-101: Conventional HSI/PTR Format with Loss of Navigation Condition



Figure 3-102: ND (HSI with DME on Hold)

When VOR1 and VOR2 pointers are selected for display, a bearing and distance display at the bottom of the ND appear. If bearing or distance is not valid, the respective field is filled with dashes. If a DME channel is in hold mode, the associated distance readout is displayed in amber (yellow) rather than blue or green, and the letter “H” is shown above the distance readout as seen in Figure 3-102.

The ownship symbol is as follows:

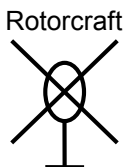


Figure 3-103: HSI Ownship Symbols (Centered on the HSI and Pointing Straight Up)

The HSI has a compass rose aligned with either magnetic North or True North depending upon the status of the True North discrete input (if enabled upon installation). When the HSI NAV source fails (FMS, VOR1, or VOR2), a red “X” is displayed in place of the HSI deviations.

3.16.1. Compass Rose Symbols

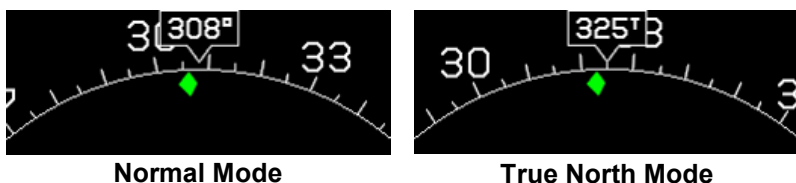


Figure 3-104: Compass Rose

When selected, a digital heading readout and pointer aligned with the longitudinal axis of the ownship symbol appear on the compass rose boundary circle. If referenced to magnetic North, the heading readout uses the degree (°) symbol. Otherwise, a stylized True North (T) symbol is used. A green diamond-shaped track pointer aligned with the aircraft’s track across the earth appears on the compass rose and is displayed when groundspeed is less than 30 knots. The pilot-settable heading bug geometrically interacts with the heading pointer on the compass rose. A magenta, star-shaped waypoint pointer is displayed on the heading scale at a point corresponding with the active waypoint and turns amber (yellow) in the event of GPS Loss of Navigation caution.

NOTE:

See Section 7 IFR Procedures for description of the following heading modes with the ADAHRS and EFIS:

- 1) ADAHRS Slaved—EFIS Magnetic North
- 2) ADAHRS Slaved—EFIS True North
- 3) ADAHRS Free/“DG”—EFIS Magnetic North
- 4) ADAHRS Free/“DG”—EFIS True North

The following data items are displayed in the upper right corner of the HSI:

Zulu Time: Shown in hours:minutes:seconds format and synchronized with the GPS/SBAS constellation

Timer: A countdown or count-up timer is displayed when selected. Timer matches the timer shown on the PFI area.

HSI Source: Shown when the HSI is slaved to GPS/SBAS. HSI source is white, but turns amber (yellow) if there is a GPS Loss of Navigation.

OBS: OBS setting associated with the HSI source is shown. When the HSI source is FMS, the FMS OBS setting matches the OBS setting shown on the PFD FMS CDI. The FMS OBS setting is labeled with an “A” for automatic or “M” for manual. The OBS setting is white, but when the HSI is slaved to GPS/SBAS and there is a GPS Loss of Navigation condition it turns amber (yellow).

CDI Scale: The current CDI scale is shown and matches the CDI scale shown on the PFI course deviation. The CDI scale is white as seen on Figure 3-105 and Figure 3-106. When the HSI is slaved to GPS/SBAS and there is a GPS Loss of Navigation condition, the CDI scale is amber (yellow).



Figure 3-105: HSI CDI Scale



Figure 3-106: HSI CDI Scale (with LON Condition)

3.16.2. HSI Screen (AW-109SP)

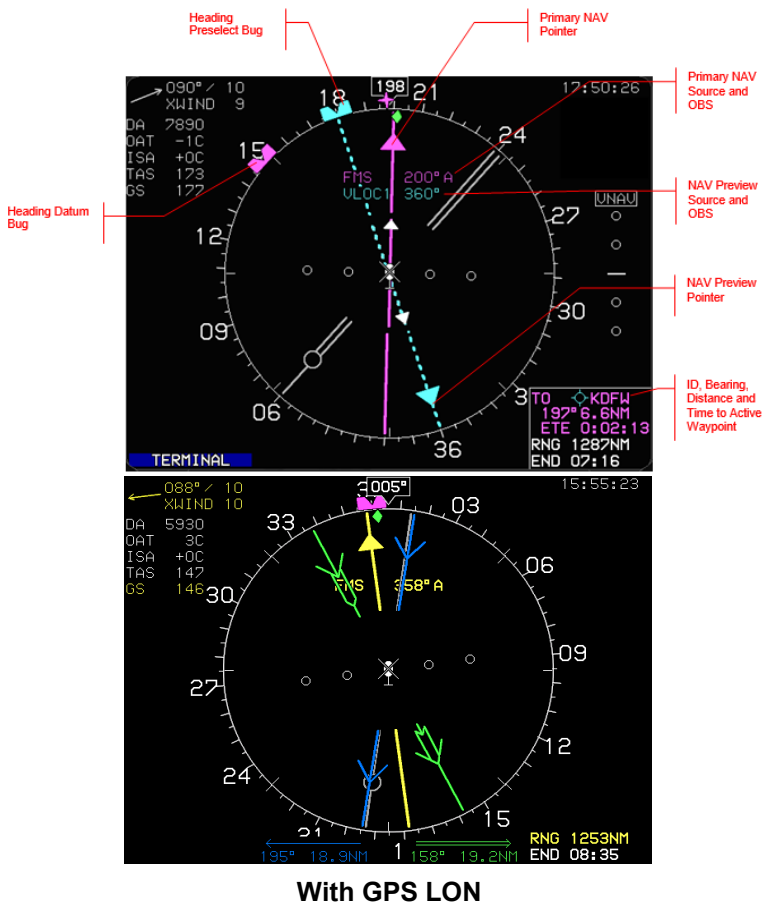


Figure 3-107: HSI Screen (AW-109SP)

3.16.3. Compass Rose Symbols (AW-109SP)

The Compass Rose has a Heading Datum Bug and Heading Preselect Bug. The Heading Datum Bug and Heading Preselect Bug are shaped to geometrically interact with the present heading pointer symbol. The Heading Datum Bug is filled-magenta, and the Heading Preselect Bug is filled-cyan. When the two bugs overlap, the Heading Datum Bug is drawn on top of the Heading Preselect Bug.

The AFCS communicates the Heading Preselect and Datum Bug values to the EFIS.

The color of the star-shaped active waypoint pointer is determined using Table 3-10.

3.16.4. Vertical Deviation Indicator (AW-109SP)

The color of the Vertical Deviation Indicator is determined using Table 3-12.

3.16.5. Primary NAV Pointer (AW-109SP)

The Primary NAV Pointer is drawn as a solid line of the color determined using Table 3-10. Navigation source indication and OBS setting are displayed in the top center portion of the HSI and are the same color as the Primary NAV Pointer.

3.16.6. NAV Preview Pointer (AW-109SP)

When a NAV Preview is selected, the HSI page displays a NAV Preview Pointer indicating the NAV Preview selected course, deviation, and TO/FROM in a standard HSI format. The NAV Preview Pointer is a dashed cyan line to differentiate it from the Primary NAV Pointer. When the AFCS armed mode indicates BC, LOC, VAPP, TCN, or VOR, the NAV Preview pointer flashes with a 1Hz 60% duty cycle indicating the AFCS is about to switch from NAV mode to the armed mode. Upon switching, the armed mode uses the NAV Preview source as its Primary NAV source. The NAV Preview Pointer TO/FROM indicator is a solid white triangle. There is not a deviation scale associated with the NAV Preview Pointer to avoid confusion with the Primary NAV Pointer deviation scale. NAV Preview source indication and OBS setting are displayed in the top center portion of the HSI and are the same color as the NAV Preview Pointer.

3.16.7. Identifier, Bearing, Distance and Time to Active Waypoint (AW-109SP)



Color for rendering the identifier, bearing, distance, and time to the active waypoint is determined using Table 3-10. Distance information in a RF Leg is geodetic bearing/distance as opposed to a long-path distance.

Figure 3-108: Identifier, Bearing, Distance, and Time to Active Waypoint (AW-109SP)

NOTE:

When a MOT flight pattern is being displayed, these values are derived from the AFCS.

3.16.8. Fuel Totalizer/Waypoint Bearing and Distance Functions

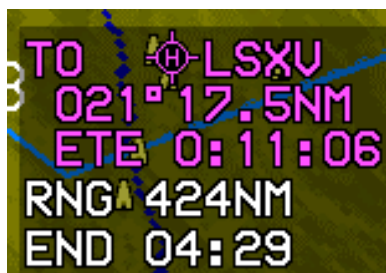


Figure 3-109: Fuel Totalizer/Waypoint Bearing and Distance Functions

Table 3-19: Fuel Totalizer/Waypoint Bearing and Distance Functions

Function	Conditions	Type Symbols Options
TO Waypoint:	<p>If there is an active flight plan, waypoint type, identifier, range, bearing, and estimated time enroute/estimated time of arrival for the active waypoint (“TO” waypoint) of the active flight plan are shown.</p> <p>Waypoint information is magenta and turns amber (yellow) in the event of a GPS Loss of Navigation caution.</p>	<p>ETA or ETE</p> <p>Degree (°) symbol or True North (T) symbol</p>
DEST Waypoint:	<p>If there is an active flight plan, waypoint type, identifier, range, and estimated time enroute/estimated time of arrival for the last waypoint (“DEST” waypoint) of the active flight plan are shown.</p> <p>Range and time to the destination waypoint are based upon the flight plan route, if the active waypoint is not the last waypoint, otherwise range and time to the destination waypoint are based upon a direct geodetic path.</p> <p>The DEST Waypoint information is white and turns amber (yellow) in the event of a GPS Loss of Navigation caution.</p>	<p>ETA or ETE</p> <p>Degree (°) symbol or True North (T) symbol</p>

Table 3-19: Fuel Totalizer/Waypoint Bearing and Distance Functions

Function	Conditions	Type Symbols Options
Range:	Aircraft range based upon instantaneous fuel flow, fuel remaining, and groundspeed are shown immediately below the "DEST" waypoint information for easy comparison.	
Endurance:	Aircraft endurance based upon instantaneous fuel flow and fuel remaining is shown.	

3.16.9. Clock/Timers/Options


Figure 3-110: Clock and Timers

The following data items are displayed in the upper right corner of the ND.

Table 3-20: Clock/Timers/Options

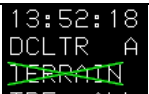
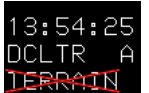

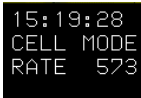
Feature	Options	Notes
Zulu Time	No other format available	hh:mm:ss format and synchronized with the GPS/SBAS constellation.
Timer	COUNT UP COUNT DN.. FLT TIME	Countdown or count-up timer displayed when selected and matches timer shown on PFD.
Declutter Mode	DCLTR A DCLTR M	= Automatic declutter mode = Manual declutter mode
Terrain Status	Enabled or Disabled	  <p>Status annunciated as “TERRAIN” with overlying “X”, if manually deselected. If TERRAIN is decluttered from the PFI area, the only indication is the absence of terrain from the PFI area. If TERRAIN is disabled, the “X” is red.</p>
Traffic Status	Enabled or Disabled	 <p>Status annunciated disabled if manually deselected. In the event of a traffic warning (TA or RA), traffic thumbnail is automatically enabled while traffic warning is active and aircraft is above 500’AGL.</p> <p>If traffic is disabled, the “X” is red. When traffic is selected and enabled, status of traffic altitude filtering is displayed as follows: AUTO = TRF AUTO, NORMAL = TRF NORM, ABOVE = TRF ABV, ALL = TRF ALL, BELOW = TRF BLW.</p>

Table 3-20: Clock/Timers/Options

Feature	Options	Notes
WX-500 Status	Enabled or Disabled	 <p>When selected, ND displays Cell Mode lightning strikes in correct relationship to the ownship symbol with the limits found in § 3.26.</p>

3.17. Navigation Log

WAYPOINT	UNAU/OFFSET	PATH	DIST	ETE	ETA	FUEL
14:07:21 GS 112						
		FUEL 3174LBS FLOW 252PPH				
✕ START	7200' / ---NR	-DISCONT-	35.0 _{NR}	0+18	14:06	3174
GPP IP	5821' / ---NR	θ+ 305°	12.0 _{NR}	0+06	14:06	3174
FAF ✱COOPE	1939' / ---NR	θ+ 305°	5.4 _{NR}	0+02	14:26	3094
FBP RW30	207' / ---NR	303° 1000'	0.0 _{NR}	0+00	14:29	3082
FBP	1000' / ---NR	θ+ 102°	8.3 _{NR}	0+04	14:29	3082
HYP	2000' / ---NR	↻ 290°	5.6 _{NR}	0+02	14:33	3063
HYP	2000' / ---NR	-----	-----	---+---	14:36	3051
KMCE	-----' / ---NR	-----	-----	-----	---	-----

Figure 3-111: Navigation Log

3.17.1. Clock and Groundspeed

The following data items are displayed in the upper left corner of the NAV Log:

- 1) Zulu Time: As specified in § 3.16.9.
- 2) Groundspeed: Displayed digitally in knots, Fuel Remaining, and Fuel Flow Data.

3.17.2. Fuel Remaining and Fuel Flow Data

The following data items are displayed in the upper right corner of the NAV Log:







Fuel Remaining: If either fuel level or fuel flow is available, current fuel remaining is displayed digitally in fuel units.

Fuel Flow: If fuel flow is available, current total fuel flow is displayed digitally in fuel units.

3.17.3. Waypoint Identifier Column

The identifier for each waypoint of the active flight plan is displayed in the left-most column of the NAV Log. The current active waypoint is indicated with an asterisk and shown in magenta (cyan for AW-109SP) and turns amber (yellow) in the event of a GPS Loss of Navigation caution. Suppressed waypoints are indicated by brackets. Navigation data symbols are shown with the waypoint identifier for the pilot to easily distinguish the waypoint type. In the case of an airport with an available datalinked METAR, a graphical METAR is displayed as color-filled circular part of the airport symbol with the following coloring convention.

Table 3-21: Graphical METAR Symbols

Color		Meaning
Sky Blue		Visual Flight Rules (VFR)
Green		Marginal Visual Flight Rules (MVFR)
Amber (Yellow)		Instrument Flight Rules (IFR)
Red		Low Instrument Flight Rules (LIFR)
Magenta		Less than Category 1 Approach Minimums
Black		No Data

When a waypoint is part of a procedure or parallel offset, legends are drawn on top of the navigation data symbol. The following legends are used:

- 1) **FAF** = Waypoint is a Final Approach Fix
- 2) **MAP** = Waypoint is a Missed Approach Point
- 3) **MA** = Waypoint is part of the missed approach segment of an Instrument Approach Procedure.
- 4) **APP** = Waypoint is part of an Instrument Approach Procedure, but is not a Final Approach Fix, Missed Approach Point, or part of the Missed Approach segment.

- 5) **VFR** = Waypoint is part of a VFR Approach.
- 6) **STAR** = Waypoint is part of a Standard Terminal Arrival Procedure.
- 7) **DP** = Waypoint is part of a Departure Procedure.
- 8) **PTK** = Parallel Offset. In case of a STAR or DP waypoint subject to a parallel offset, both STAR/DP and PTK are shown.

3.17.4. VNAV and VNAV Offset Column


The VNAV altitude and associated VNAV Offset (in NM) are displayed immediately to the right of the Waypoint Identifier Column. In the case of an approach with a Final Approach Segment data block, the VNAV Offset readout associated with the Missed Approach Point is “GPI” to designate distance to the Glidepath Intercept Point. VNAV altitudes and offsets from the navigation database or manually entered are shown in white. VNAV altitudes and offsets computed automatically are shown in gray. The vertical position of the VNAV and VNAV Offset Column elements are aligned with the Waypoint Identifier Column elements to indicate the VNAV information applies to the associated waypoint.

NOTE:

No VNAV data (dashes) is associated with a suppressed waypoint, as a suppressed waypoint is not actually part of the active flight plan.

3.17.5. Path Column

The LNAV path between waypoints is displayed immediately to the right of the VNAV and VNAV Offset Column. The following paths are displayed:

- 1) Geodetic path between waypoints is displayed with the “Direct-To” symbol,  (**R4**), followed by the initial geodetic course for the leg.
- 2) Discontinuities (i.e., a leg where FMS is unable to compute a valid path) are shown with the legend -DISCONT-.
- 3) Procedure turns are shown with a pictorial representation of a procedure turn (either left or right turns) as well as the entry and exit course for the procedure turn.

- 4) Holding patterns are shown with a pictorial representation of a holding pattern (either left or right turns) as well as the inbound course for the holding pattern.
- 5) Arcs are shown with a pictorial representation of an arc (either left or right turns) as well as the entry and exit radials for the arc.
- 6) An altitude termination leg is shown by the initial geodetic course for the leg followed by the altitude at which the leg terminates.

The vertical position of the Path Column elements is offset from the Waypoint Identifier Column elements to indicate the path information applies to the leg between waypoints.

3.17.6. Distance Column

The distance between waypoints is displayed immediately to the right of the Path Column. The distance between waypoints is calculated taking into account the associated path as well as parallel offsets. In the case of a discontinuity, the distance between waypoints is the direct geodetic distance between the two waypoints. The vertical position of the Distance Column elements is offset from the Waypoint Identifier Column elements to indicate the distance information applies to the leg between waypoints.

3.17.7. Estimated Time Enroute Column

The ETE between waypoints is displayed immediately to the right of the Distance Column. The ETE between waypoints is calculated taking into account the associated distance between waypoints and current groundspeed. The vertical position of the Estimated Time Enroute Column elements is offset from the Waypoint Identifier Column elements to indicate the ETE information applies to the leg between waypoints.

3.17.8. Estimated Time of Arrival Column

The ETA at the active waypoint and all subsequent waypoints are displayed immediately to the right of the Estimated Time Enroute Column. The ETA at the active waypoint is calculated taking into account the associated time remaining on the active leg and current time. The ETA at subsequent waypoints is calculated taking into account the cumulative ETES and current time. The vertical position of the Estimated Time of Arrival Column elements is aligned with the

Waypoint Identifier Column elements to indicate the ETA information applies to the associated waypoint.

3.17.9. Fuel Remaining Column

The fuel remaining at the active waypoint and all subsequent waypoints is displayed immediately to the right of the Estimated Time of Arrival Column. The fuel remaining at the active waypoint is calculated taking into account the associated time remaining on the active leg, current fuel flow, and current fuel quantity. The fuel remaining at subsequent waypoints is calculated taking into account the cumulative ETEs, current fuel flow, and current fuel quantity. The vertical position of the Fuel Remaining Column elements is aligned with the Waypoint Identifier Column elements to indicate the fuel remaining information applies to the associated waypoint.

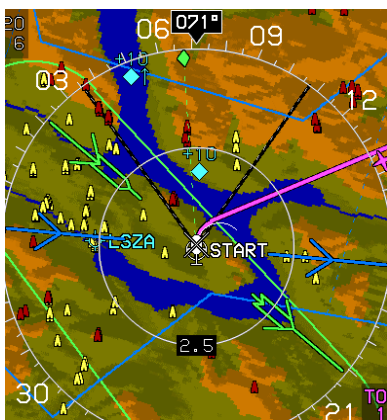
NOTE:

The absence of the following is associated with a suppressed waypoint, as a suppressed waypoint is not actually part of the active flight plan:

- 1) Path data (dashes)
- 2) Distance data (dashes)
- 3) ETE data (dashes)
- 4) ETA data (dashes)
- 5) Fuel remaining data (dashes)

3.18. Start Point

Activation of the NRST or Direct-To function creates and activates a flight plan from the present position to the selected waypoint. A waypoint named "START" (See Figure 3-112) is placed at the current aircraft location when the flight plan is created.



(Other Rotorcraft)



(AW-109SP)

Figure 3-112: Start Point

3.19. Altitude Capture Predictor

3.19.1. Top of Descent

When a selected altitude or VNAV is specified on the PFD, the point at which a descent must be commenced is marked with a T/D in the correct location on the flight plan path and contain location on the flight plan path with an indication of the glidepath angle used to calculate their position. After passing the Top of Descent along the lubber line, the altitude is captured and shown as a green arc located ahead of the aircraft. The arc marks the bottom-of-descent or top-of-climb point.

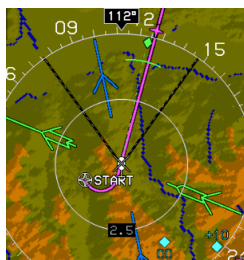
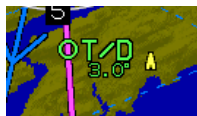
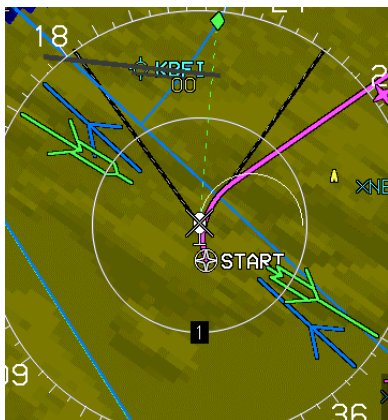


Figure 3-113: Top of Descent or Top-of-Climb

3.19.2. Projected Path



When the aircraft is in a bank angle, a projected path emanates from the ownship symbol. This curving path is based upon the aircraft bank angle and groundspeed as it projects one minute into the future up to a maximum of 180° of turn.

The projected path or “noodle” assists in course interception and making small adjustments to bank angle for proper roll out.

Figure 3-114: Projected Path

3.20. Active Flight Plan Path/Manual Course/Runways

When there is an active flight plan and the GPS/SBAS OBS setting is automatic, the flight plan path is shown on the ND in its correct relationship to the ownship symbol. The active flight plan path depiction meets all the requirements of GPS/SBAS path definition and matches the lateral navigation guidance given on the PFD (GPS/SBAS CDI in automatic OBS mode, skyway boxes, and mini-map). The fly-over waypoint symbol is distinct from fly-by waypoints and consists of the waypoint symbol within a circle. When there is a parallel offset, the active flight plan path depicts the parallel offset path, and the original flight plan path is shown with haloed gray dashed lines. Top of descent symbols with an indication of glidepath angle are shown where VNAV descents are predicted to commence.

When there is an active waypoint and the GPS/SBAS OBS setting is manual, the manual course through the waypoint is shown as a pointer centered on the waypoint. The pointer matches the lateral navigation guidance given on the PFD (GPS/SBAS CDI in manual OBS mode, skyway boxes, and mini-map).

The active flight plan path’s active leg/manual course and active waypoint are magenta and turn amber (yellow) in the event of a GPS Loss of Navigation caution.

The ND displays airport runways in correct relationship and scale to the ownship symbol. Upon activation of a DP, VFR approach, IFR approach, or STAR procedure, the runways for the airport associated with the procedure are displayed. In addition, the runways associated with the three nearest airports (as computed by the TAWS algorithms) are displayed.

3.21. FOV Indication

The ND background indicates the ND FOV with a set of segmented gray lines leading out from the ownship symbol in either 35° or 70° angles depending on the zoom mode setting on the PFD.

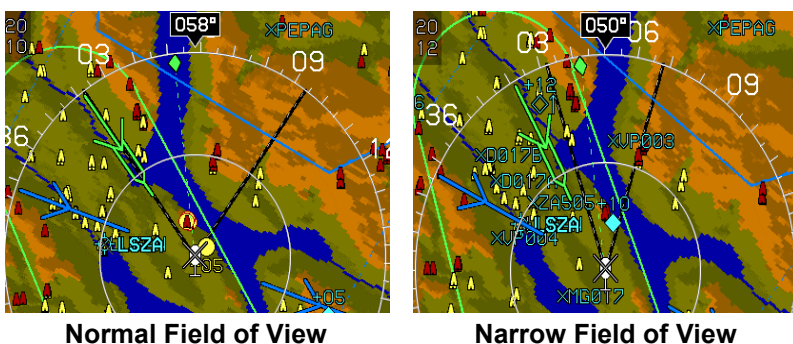


Figure 3-115: Field of View

3.22. Range

The range ring is a white ring (centered on the aircraft's position) used to quickly estimate distances. Distance (in nautical miles) from the aircraft to the ring is shown as a white figure overlaying at the 6 o'clock position of the ring. The range ring is half the distance to the directional scale. Consequently, when the range ring shows a distance of 5NM, the directional scale is 10NM. Scroll **1** to set the overall map scale to .5, 1, 2.5, 5, 10, 25, 50, 100, or 200NM.

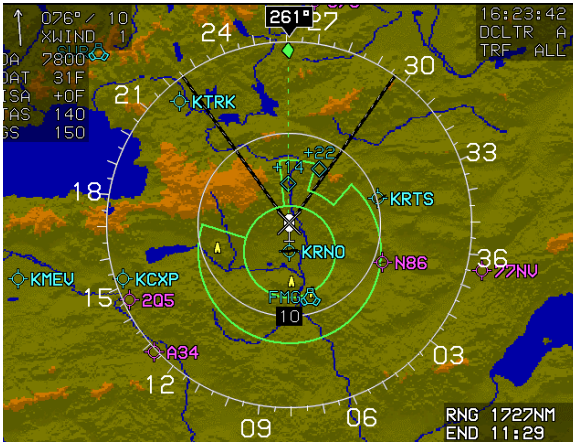
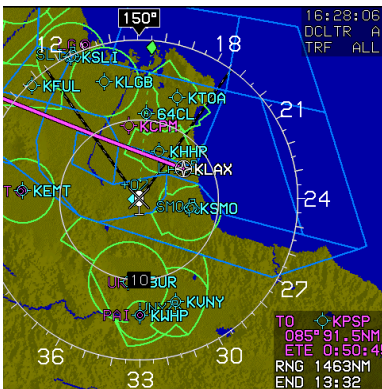


Figure 3-116: Range

3.23. Navigation Data

The ND displays navigation data in correct relationship to the ownship symbol with navigation data symbols which include airport symbols, NDBs, and user waypoints. High altitude and low altitude airways may be shown.



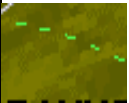
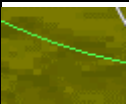
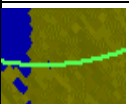

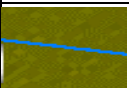
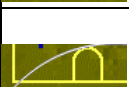
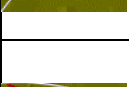
(Other Rotorcraft)



(AW-109SP)

Figure 3-117: Navigation Data and Airspace Depiction

Table 3-22: Airspace Depiction

Table 3-22: Airspace Depiction	
Type of ARINC 424 Airspace	Vertical Limits
 Single pixel, dashed lines	More than $\pm 500'$
 Single pixel solid lines	Within 500'
 Double pixel solid lines	Within airspace vertical limits
Type of ARINC 424 Airspace	Color of Airspace
 Class C, Control Area, TRSAs, Class D	Green
 Class B, TCAs (Where applicable)	Blue
 Caution Areas, Danger Areas, MOAs, Training Areas, Warning Areas, Unknown Areas	Amber (Yellow)
 Prohibited Areas, Restricted Areas, Temporary Flight Restricted Areas (When equipped with Datalink)	Red

The ND has manual and automatic decluttering of navigation data. There are six levels of automatic declutter based upon the number of navigation data symbols drawn in the current ND format and range. Decluttering is as follows:

- 1) **Airports:** Manually or automatically decluttered. In automatic declutter mode, large airports (IFR procedure and longest runway and automatically adjusted threshold needed to achieve desired symbol count) are always shown; IFR airports that are not large airports are shown in levels 1, 2, 3, and 4; and VFR airports are shown in levels 1, 2, and 3.

- 2) **VORs:** Manually or automatically decluttered. In automatic declutter mode, VORs are shown in levels 1, 2, 3, 4, and 5.
- 3) **NDBs:** Manually or automatically decluttered. In automatic declutter mode, NDBs are shown in levels 1 and 2. Both enroute and terminal NDBs are shown.
- 4) **FIXES** (including user waypoints): Manually or automatically decluttered. In automatic declutter mode, enroute fixes are shown in level 1. Terminal fixes are manually selected and not shown in automatic declutter mode. Enroute fixes, terminal fixes, and user waypoints may be manually decluttered separately from each other.
- 5) **High Altitude Airways:** Manually selected.
- 6) **Low Altitude Airways:** Manually selected.

3.23.1. Air Data and Groundspeed



True North Mode



Normal Mode

Figure 3-118: Air Data and Groundspeed

The following data items are displayed in the upper left corner of the ND as seen in Figure 3-118:

- 1) **Wind:** Information consists of the following readouts:
 - a) Direction in degrees;
 - b) Speed in knots;
 - c) Crosswind component in knots; and
 - d) Graphical wind vector arrow oriented to correspond to the ND orientation.

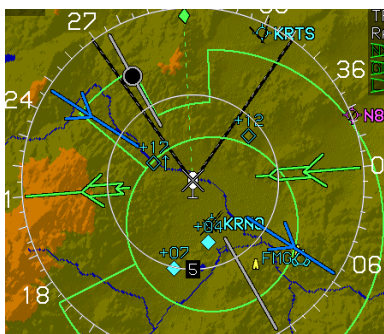
If referenced to magnetic North, the direction readout uses the degree (°) symbol. Otherwise, a stylized True North (T) symbol

is used. Wind information is not shown when indicated airspeed is in the noise range, generally less than 20 KIAS, or when the aircraft is in Ground Mode.

- 2) **Outside Air Temperature:** Digitally in Degrees C or F (as configured).
- 3) **International Standard Atmosphere (ISA):** The difference between ISA temperature and current outside air temperature is displayed digitally in Degrees C or F (Negative values = less than Standard OAT)
- 4) **Density Altitude:** Digitally in feet.
- 5) **True Airspeed:** Digitally in knots.
- 6) **Groundspeed:** Digitally in knots.

3.23.2. Analog Navigation Symbology

When selected, the ND displays analog (VOR1 and VOR2) navigation symbology, when valid.



(Other Rotorcraft)



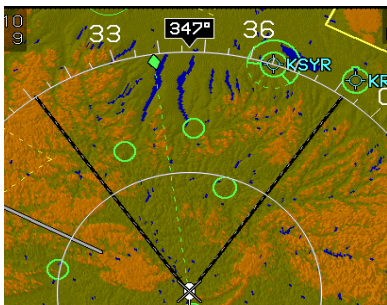
(AW-109SP)

Figure 3-119: Analog Navigation Symbology

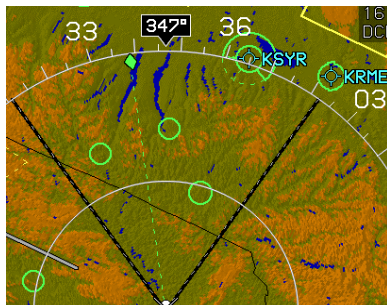
When the VOR1 and/or VOR2 pointers are selected for display, bearing and distance for the selected VOR pointers appear at the bottom of the ND view (blue for VOR1; green for VOR2). If the DME channel is in hold mode, the associated distance readout is amber (yellow), and the letter "H" is shown above the distance readout.

3.23.3. Borders

National and United States state borders are drawn if selected at map scales of 50NM or greater. The borders are white, but they are black if the ND background includes terrain.



Without State Borders Drawn



With State Borders Drawn

Figure 3-120: Borders

3.23.4. Terrain/Obstructions



Figure 3-121: Terrain/Obstructions

Terrain is displayed on the ND in its correct relationship to the ownship symbol and shown using color to show relationship to aircraft altitude as follows.

Table 3-23: Terrain Display on Navigation Display Color Relationship to Aircraft Altitude

Based on Aircraft Altitude	Color	Notes #
Terrain when at or below 100 feet less than aircraft altitude	Shades of Olive	#1
Terrain when above 100 feet less than aircraft altitude	Shades of Brown	#1
FLTA alerts	Amber and Red	#2
Water at all altitudes	Deep Blue	#3



Obstructions

Figure 3-122: Obstructions

Obstruction symbols are displayed on the ND in their correct relationship to the ownship symbol and shown using color to show relationship to aircraft altitude as follows.

Table 3-24: Obstructions

Lateral Distance Away	8.5 NM or greater	Not depicted on the ND
	8.5 NM or less	As described below
Vertical Criteria	More than 2000' below aircraft	Not depicted on the ND
	Within 2000' but more than 500' below aircraft	Depicted in amber
	Within 500' but below aircraft	Depicted in light red
	At or above aircraft altitude	Depicted in deep red.

Terrain and obstruction rendering is pilot-selectable to declutter the display by deselecting terrain (*independent declutter of obstructions is not possible*). Furthermore, terrain and obstruction rendering is disabled when:

- 1) The GPS/SBAS sensor is failed; OR
- 2) When the horizontal figure of merit exceeds the greater of 0.3NM or the horizontal alarm limit for the mode of flight.

NOTE:

See Section 8 Terrain Awareness Warning System for obstructions causing TAWS alarms and depiction of separate symbology.

3.24. Pan Mode

The ND screen has a pan mode for the pilot to change the location of the center of the screen away from current location and view map details along the route of flight and at the intended destination or alternate destination while either in flight or on the ground. When pan mode is active, labeled buttons are used to move the pan mode location North, South, East, and West in a North-up, centered orientation. Upon entering the pan mode, the heading pointer, track pointer, lubber line, waypoint pointer, analog navigation symbology, and field of view lines are removed from the display as shown in Figure 3-123.

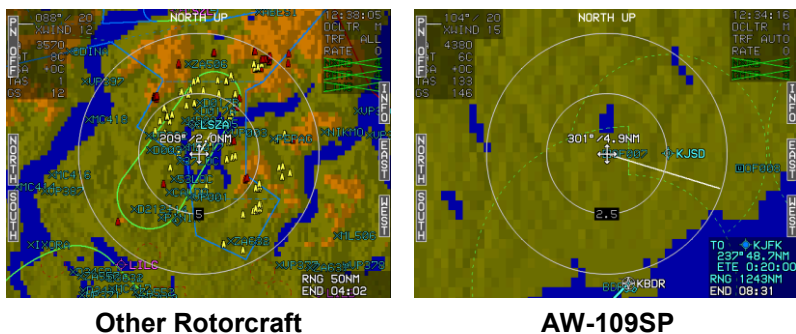


Figure 3-123: Pan Mode

Figure 3-123 shows the line with bearing and distance from the map center to the aircraft's current position in white whenever the aircraft is more than 0.5 NM away. If referenced to magnetic North, the

bearing uses the degree (°) symbol. Otherwise, a stylized True North (T) symbol is used. When panning, the nearest displayed airport, VOR, NDB, or fix within the inner range ring is highlighted with a flashing circle. Buttons are labeled to allow for viewing or hiding waypoint information (including datalink weather information associated with that point). When exiting the pan mode, all previous settings are restored as before pan mode was enabled.

3.25. HSI Screen

The ND, when selected, displays conventional HSI symbology, including a selected course needle, a lateral deviation indicator, and a “TO-FROM” indicator. When the HSI is slaved to GPS/SBAS during a GPS Loss of Navigation condition, the HSI pointer color is amber (yellow), otherwise the pointer color remains magenta.

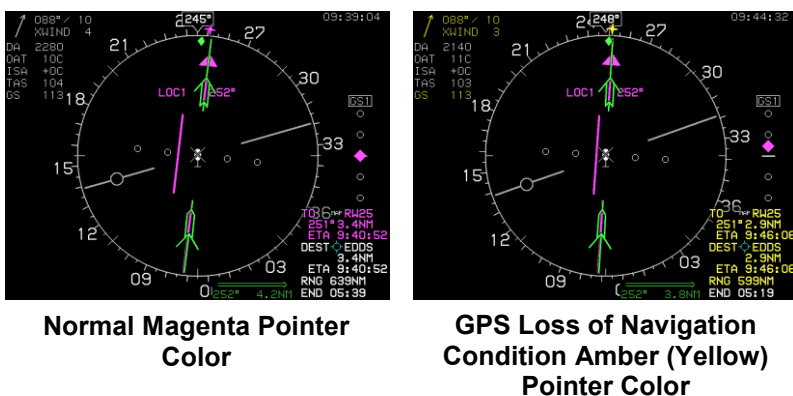


Figure 3-124: HSI Pointer Color

3.25.1. HSI Screen VDI

A vertical deviation indicator appears, as seen above, when the VDI source is valid to display vertical deviation information for the currently selected navigation source. When the selected vertical source is FMS, the VDI displayed on the HSI has the same behavior as the VDI displayed on the PFD with the exception of the VDI source displayed on the top of the VDI to avoid clutter with waypoint information below:

- 1) VNV1-B: Default FMS barometric VNAV mode.

- 2) VNV2-B: Default FMS barometric VNAV mode.
- 3) GS1: Glideslope #1
- 4) GS2: Glideslope #2

3.25.2. Analog Navigation Symbology

The HSI has the capability when selected, to display analog (VOR1 [blue] and VOR2 [green]) navigation symbology with an RMI pointer format overlaid upon the HSI. When the signal is invalid, the associated pointer is not shown. When the signal is valid for VOR1 and VOR2, a bearing and distance display for the selected VOR pointers appears at the bottom of the display as in Figure 3-125.

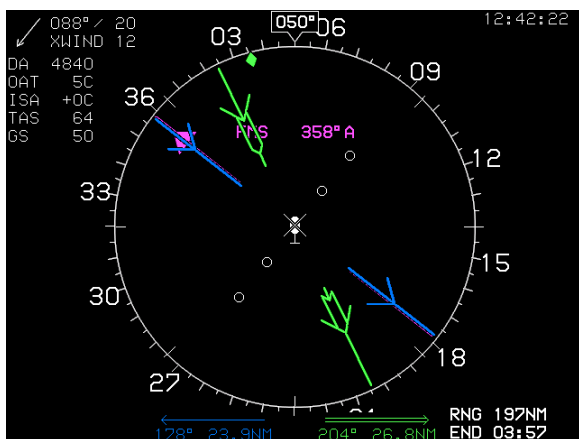


Figure 3-125: Analog Navigation Display VOR1 and VOR2

If a DME channel is in hold mode, the associated distance readout is displayed in amber (yellow) rather than blue or green, and the letter “H” is shown above the distance readout (see Figure 3-126).



Figure 3-126: HSI Bearing Distance Readout with DME in HOLD

Valid Marker Beacon discrettes are displayed as indicators on the PFD and ND HSI display as seen in Figure 3-127 with appropriate coloring markings. Only during a built-in-test may more than one marker beacon be active. The display of marker beacons is disabled when the NAV source is FMS.



Figure 3-127: HSI with Marker Beacon Displayed

3.25.3. HSI with Marker Beacon Displayed Air Data and Groundspeed

The air data and groundspeed are displayed as shown in the Figure 3-128 and the same as explained as specified in § 3.23.1.

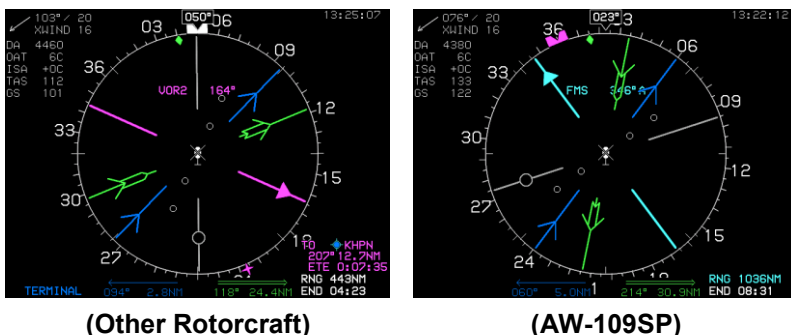


Figure 3-128: HSI Display Air Data and Groundspeed

3.25.4. Clock/Timers/Options

The following data items are displayed in the upper right corner of the HSI:

- 1) **Zulu Time:** As specified in § 3.16.9.
- 2) **Timer:** As specified in § 3.16.9.
- 3) **HSI Source:** HSI source is white but shown in amber (yellow) when the HSI is slaved to GPS/SBAS and there is a GPS Loss of Navigation.
- 4) **OBS:** The OBS setting associated with the HSI source is shown. When the HSI source is FMS, the FMS OBS setting matches the OBS setting shown on the PFD FMS CDI. The FMS OBS setting is labeled with an “A” for automatic or “M” for manual. OBS setting is white but is amber (yellow) when the HSI is slaved to GPS/SBAS and there is a GPS Loss of Navigation condition.
- 5) **CDI Scale:** The current CDI scale is shown and matches the CDI scale shown on the PFD course deviation. The CDI scale is white but is amber (yellow) when the HSI is slaved to GPS/SBAS and there is a GPS Loss of Navigation condition.



Figure 3-129: HSI Clock/Timers

3.25.5. Fuel Totalizer/Waypoint Bearing and Distance Functions



Fuel totalizer, waypoint bearing, and waypoint distance are displayed in the lower right corner of the HSI as specified in § 3.16.8.

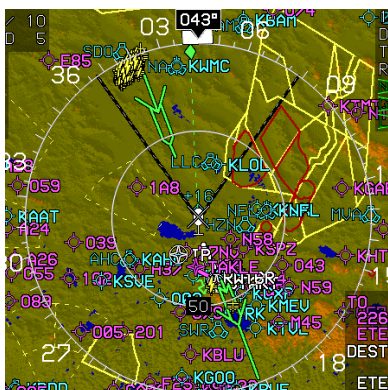
Figure 3-130: HSI Fuel Totalizer/Waypoint Bearing

3.26. WX-500 Data

When selected, the ND displays Cell Mode lightning strikes in their correct relationship to the ownship symbol with the following limits.

Table 3-25: Lightning Strikes

View	Time or Distance Limit
Strikes not shown	Display scale less than 25 NM
Strikes not shown	More than 3 minutes old
Strikes less than 20 seconds old	Shown with lightning symbol
Strikes between 20 seconds and 2 minutes old	Shown with large cross symbol
Strikes between 2 minutes and 3 minutes old	Shown with small cross symbol


ND Lightning Display

Strike Screen Display Format
Figure 3-131: Lightning Symbols

The pilot may select either an arced or centered display format with the ownship displaced toward the bottom of the screen, so strike data is displayed in a larger scale while displaying all data within range ahead of the aircraft. The strike screen has “Strikefinder” markings aligned with either magnetic North or True North depending upon the status of the True North discrete input.

3.26.1. Strike Screen Range

The following strike screen ranges may be selected with all distances representing the distance from the ownship symbol to the “Strikefinder” markings: 12.5 NM, 25 NM, 50 NM, 100 NM, and 200 NM. The range ring is centered upon the ownship symbol to help judge range to displayed symbols. The range ring has half the radius of the “Strikefinder” markings displayed indicating the range corresponding to the radius of the range ring such as (1.5 NM, 25 NM, 50 NM, and 10 NM.) The range ring is completely visible in arced display format for the pilot to ascertain the current strike screen setting.

3.26.2. Active Flight Plan Path/Manual Course/Runways



Figure 3-132: Active Flight Plan Path/Manual Course/Runways

When there is an active flight plan and the GPS/SBAS OBS setting is automatic, the flight plan path is shown on the strike screen in its correct relationship to the ownship symbol. The active flight plan path depiction is as specified in § 3.20.

When there is an active waypoint and the GPS/SBAS OBS setting is manual, the manual course through the waypoint is shown as a pointer centered on the waypoint. The pointer matches the lateral navigation guidance given on the PFD (GPS/SBAS CDI in manual OBS mode, skyway boxes, and mini-map).

The active flight plan path's active leg/manual course and active waypoint are magenta and turn amber (yellow) in the event of a GPS Loss of Navigation caution.

The strike screen displays airport runways in their correct relationship and scale to the ownship symbol as specified in § 3.20.

A new strike rate value is calculated every five seconds during normal operation based upon strikes within the selected display range. The number of fresh strikes (less than 20 seconds old) is used to generate a strike rate representing strikes per minute. Strike rate increases are displayed immediately upon calculation, while decreases in strike rate are damped. Activating the strike clear function resets the strike rate to zero.

3.27. Dedicated Traffic Screen

When selected, a traffic screen is available based roughly on the appearance of a TCAS display. The traffic screen has the following elements.

3.27.1. Ownship Symbol

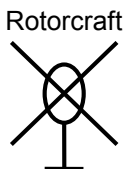


Figure 3-133: Dedicated Traffic Screen Ownship Symbol

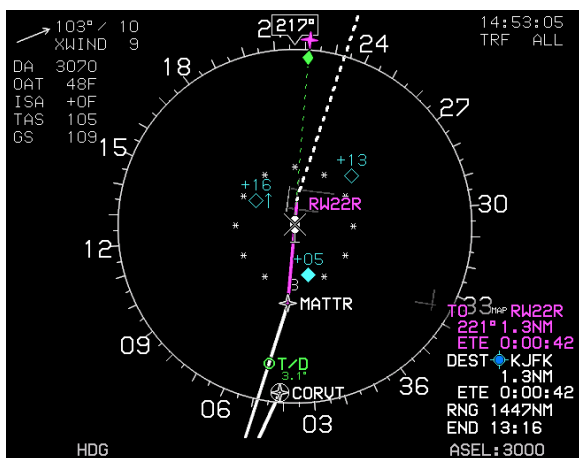


Figure 3-134: Traffic Display Format

Traffic display is a centered display format with the ownship symbol centered in the traffic screen with data displayed out to an equal distance in all directions. The compass rose aligns with either magnetic North or True North depending upon the status of the True North discrete input.

3.27.2. Traffic Screen Range

The available traffic screen selected ranges are (all distances represent distance from the ownship symbol to the compass rose): 5NM, 10NM, and 20NM.

A TCAS range ring is centered upon the ownship symbol to help judge range to displayed symbols with a 3NM radius in 5NM and 10NM ranges and has a radius half the range in 20NM, 50NM, and 100NM ranges and presented on the TCAS range ring (e.g., 3NM, 10NM, 25NM, or 50NM).

3.27.3. Compass Rose Symbols



Figure 3-135: Traffic Screen Range Compass Rose Symbols

A digital heading readout and pointer aligned with the longitudinal axis of the ownship symbol appear on the compass rose boundary circle. Compass rose symbols are as specified in § 3.16.1. A green dashed lubber line connects the center of the aircraft symbol and the track pointer. If a target altitude is set and not captured, an altitude capture predictor arc is displayed on the lubber line at a point corresponding with predicted climb or descent distance (based upon current VSI). A top of descent symbol is shown at the point where a VNAV descent is predicted to commence. The track pointer, lubber line, altitude capture predictor arc, and top of descent symbol are not displayed when groundspeed is less than 30 knots. A pilot-settable heading bug geometrically interacting with the heading pointer appears on the compass rose. A magenta, star-shaped waypoint pointer is displayed on the heading scale at a point corresponding with the active waypoint and turns amber (yellow) in the event of GPS Loss of Navigation caution.

3.27.4. Active Flight Plan Path/Manual Course/Runways

When there is an active flight plan and the GPS/SBAS OBS setting is automatic, the flight plan path, when selected, is shown on the

traffic screen in correct relationship to the ownship symbol. The active flight plan path depiction meets all the requirements of GPS/SBAS path definition and matches the lateral navigation guidance given on the PFD (GPS/SBAS CDI in automatic OBS mode, skyway boxes, and mini-map). Active flight plan path waypoint symbols for fly-over waypoints are distinct from fly-by waypoints and consist of the waypoint symbol within a circle. When there is a parallel offset, the active flight plan path depicts the parallel offset path, and the original flight plan path is shown with haloed gray dashed lines.

When there is an active waypoint and the GPS/SBAS OBS setting is manual, the manual course through the waypoint is shown as a pointer centered on the waypoint and matches the lateral navigation guidance given on the PFD (GPS/SBAS CDI in manual OBS mode, skyway boxes, and mini-map).

The active flight plan path's active leg/manual course and active waypoint are magenta and turn amber (yellow) in the event of a GPS Loss of Navigation caution.

The traffic screen displays airport runways in their correct relationship and scale to the ownship symbol as specified in § 3.20.

3.27.5. Dedicated Traffic Screen (AW-109SP)

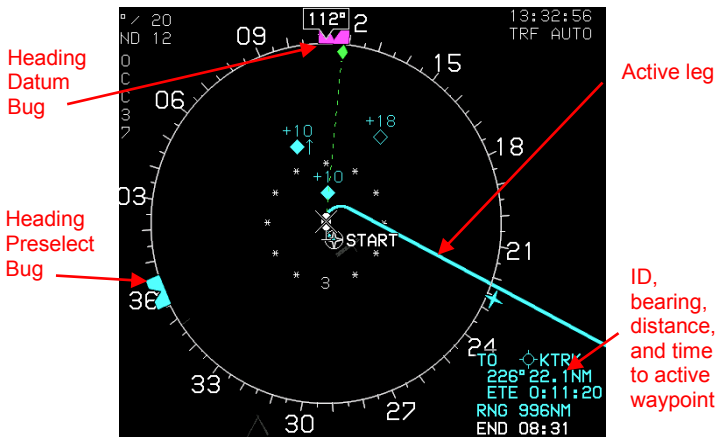


Figure 3-136: Dedicated Traffic Screen (AW-109SP)

3.27.6. Compass Rose Symbols (AW-109SP)

The Compass Rose has a Heading Datum Bug and a Heading Preselect Bug shaped to geometrically interact with the present heading pointer symbol. The Heading Datum Bug is filled-magenta, and the Heading Preselect Bug is filled-cyan. When the two bugs overlap, the Heading Datum Bug is drawn on top of the Heading Preselect Bug. The AFCS communicates the Heading Preselect and Datum Bug values to the EFIS. The color of the star-shaped active waypoint pointer is determined using Table 3-10.

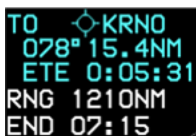
3.27.7. Active Leg of Active Flight Plan Path (AW-109SP)


Active leg color in the flight plan path is determined by Table 3-10.

NOTE:

When a MOT flight pattern is displayed, the active leg includes all legs between the “From” and “To” waypoints.

3.27.8. Identifier, Bearing, Distance and Time to Active Waypoint (AW-109SP)



TO  KRNO
078° 15.4NM
ETE 0:05:31
RNG 1210NM
END 07:15

The color for rendering the identifier, bearing, distance, and time to the active waypoint is determined by using Table 3-10.

Figure 3-137: Identifier, Bearing, Distance, and Time to Active Waypoint (AW-109SP)

NOTE:

When a MOT flight pattern is being displayed, these values are derived from the AFCS.

3.27.9. Dedicated Strike (WX-500) Screen (AW-109SP)



Figure 3-138: Dedicated Strike (WX-500) Screen (AW-109SP)

3.27.10. Active Leg of Active Flight Plan Path (AW-109SP)

Active leg color in the flight plan path is determined by Table 3-10.

NOTE:

When a MOT flight pattern is displayed, the active leg includes all legs between the “From” and “To” waypoints.

3.27.11. Identifier, Bearing, Distance, and Time to Active Waypoint (AW-109SP)

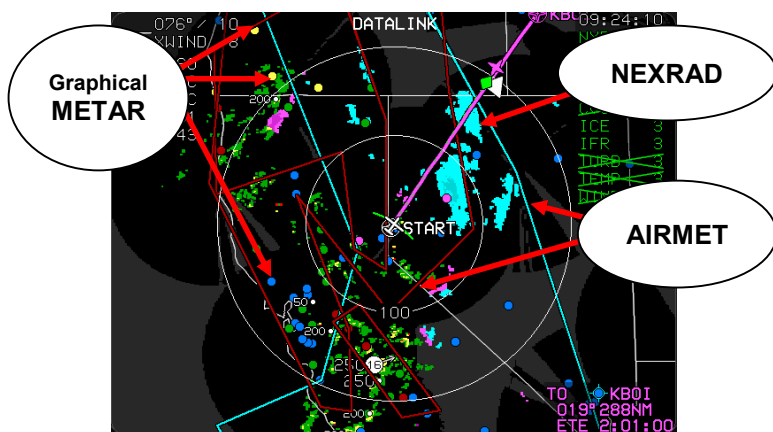


The color for rendering the identifier, bearing, distance, and time to the active waypoint is determined using Table 3-10.

Figure 3-139: Identifier, Bearing, Distance, and Time to Active Waypoint (AW-109SP)

NOTE:

When a MOT flight pattern is being displayed, these values are derived from the AFCS.

3.28. Datalink Symbolology**Figure 3-140: Datalink Symbolology**

When individually selected, the ND displays and annunciates status for Temporary Flight Restriction, NEXRAD radar, graphical METAR, and Lightning ground strike data. Only the following products received are supported and displayed according to the following table.

Table 3-26: WSI Inflight™ Data Products

Temporary Flight Restriction Data	Available if included in user subscription
NEXRAD Radar Data	Available if included in user subscription
Graphical METAR Data	Available if Textual METAR data is included in user subscription. Derived from Textual METAR data using EFIS algorithm.
Lightning Ground Strike Data	Available if included in user subscription

Datalink Temporary Flight Restriction Data Status: When Temporary Flight Restriction Data has not completely downlinked, status is annunciated as “TFR” with an overlying red “X”.

NOTE:

Up to 300 Temporary Flight Restrictions may be displayed.

Temporary Flight Restrictions (TFRs) are displayed on the ND in their correct relationship to the ownship symbol. The NEXRAD Radar Data is displayed on the ND in its correct relationship as colored regions of precipitation using the following convention.

Table 3-27: Datalink NEXRAD Radar Data

Color	Meaning
Gray Shading	Areas beyond the limits of radar coverage or areas with missing data
Magenta	Rain \geq 50dBZ
Red	Rain \geq 45dBZ and $<$ 50dBZ
Light Red	Rain \geq 40dBZ and $<$ 45dBZ
Amber (Yellow)	Rain \geq 30dBZ and $<$ 40dBZ
Green	Rain \geq 20dBZ and $<$ 30dBZ
Cyan	Snow \geq 20dBZ
Light Cyan	Snow \geq 5dBZ and $<$ 20dBZ
Magenta	Mixed Precipitation \geq 20dBZ (Area is distinguishable from Rain \geq 50dBZ by graphical context)
Light Magenta	Mixed Precipitation \geq 5dBZ and $<$ 20dBZ

Echo tops (the vertical height of NEXRAD Radar Data returns) are displayed on the datalink screen in correct relationship to the ownship symbol. Echo tops are automatically decluttered at 400NM, 800NM, and 1,600NM screen ranges. Major echo tops (i.e., the group of highest returns on the currently displayed datalink screen) are displayed as a large circle containing a textual readout of speed and a graphical arrow indicating direction of travel. The height of the major echo top, in hundreds of feet, is textually displayed to the right of the major echo top symbol. The echo top symbol is color-coded and presents amplifying text as follows.

Table 3-28: Datalink NEXRAD Echo Tops

Severe Weather Condition	Color	Amplifying Text
Possible Hail	Light Cyan	HAIL
Confirmed Hail	Light Cyan	HAIL+
Mesocyclonic (Rotation Detected)	Red	MESO
Tornadic	Magenta	TRNDO

Minor echo tops are displayed as a small white circle with the height of the minor echo top, in hundreds of feet, being textually displayed to the left of the minor echo top symbol. The text size for the minor echo top symbol is smaller than for the major echo top symbol.

Graphical METARs are displayed on the datalink screen in their correct relationship to the ownship symbol as a large color-filled circle in accordance with the following convention.

Table 3-29: Datalink Graphical METARs

Color	Meaning
Sky Blue	Visual Flight Rules (VFR)
Green	Marginal Visual Flight Rules (MVFR)
Amber (Yellow)	Instrument Flight Rules (IFR)
Red	Low Instrument Flight Rules (LIFR)
Magenta	Less than Category 1 Approach Minimums
Black	No Data

Table 3-30: Graphical METARS (GMETARS) Screen Range

Screen Range	Display
50 NM	All GMETARS with airport symbol and ID
100 NM	All GMETARS with airport symbol only
200 NM	All GMETARS
400 NM	VFR GMETARS are decluttered
800NM and 1,600 NM	VFR and MVFR GMETARS are decluttered

Graphical METARs are also displayed in the menu system “nearest airport”, “nearest weather”, and “info” functions.

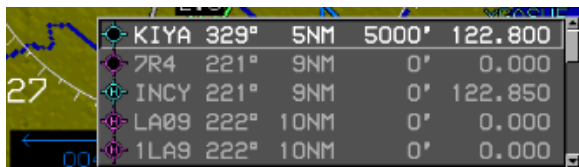


Figure 3-141: NRST Airport INFO

Graphical weather conditions data are displayed in the menu system “info” function as large colored squares as per the following convention.

Table 3-31: Datalink Graphical METAR Precipitation

Color	Meaning
Sky Blue	No Significant Precipitation
Green	Rain
White	Snow
Red	Hazardous Weather
Right Half Gray	Obscuration to Visibility
Small Black Square Centered in Large Square	High Wind
Black	No Data

The following data may be displayed on the datalink screen:

- 1) **Lightning ground strikes:** In correct relationship to the ownship symbol as a small, amber (yellow) cross symbol.
- 2) **Convective SIGMET:** As magenta line segments showing the boundary of the area in correct relationship to the ownship symbol. The pilot may view the text of individual convective SIGMETs. When viewing text, the associated convective SIGMET symbol flashes.
- 3) **Icing AIRMET and SIGMET:** As cyan line segments showing the boundary of the area in correct relationship to the ownship symbol. The pilot may view the text of individual icing AIRMETS and SIGMETs. When viewing text, the associated icing AIRMET or SIGMET symbol flashes.

- 4) **IFR AIRMET and SIGMET:** As red line segments showing the boundary of the area in correct relationship to the ownship symbol. The pilot may view the text of individual IFR AIRMETs and SIGMETs. When viewing text, the associated IFR AIRMET or SIGMET symbol flashes.
- 5) **Turbulence AIRMET and SIGMET:** As amber (yellow) line segments showing the boundary of the area in correct relationship to the ownship symbol. The pilot may view the text of individual turbulence AIRMETs and SIGMETs. When viewing text, the associated turbulence AIRMET or SIGMET symbol flashes.



Figure 3-142: Datalink Winds and Temperature Aloft

Winds and temperature aloft data are displayed on the datalink screen in correct relationship to the ownship symbol as a grid of black squares containing textual readouts of wind speed and temperature (in units determined by the Temp Units flag) and a graphical arrow indicating wind direction. When winds and temperature aloft data are displayed, soft tiles are present to allow the pilot to change the data altitude.

Textual METAR and TAF data are displayed when appropriate in the menu system “info” function.

NOTE:

Time of observation and forecast are contained within the text.

3.28.1. Datalink Screen Legend

A datalink screen legend appears, when selected by the pilot, for depicting symbology used for Graphical METARs, AIRMETs, SIGMETs, NEXRAD Radar with winter colors, echo tops, temperatures aloft, and winds aloft.

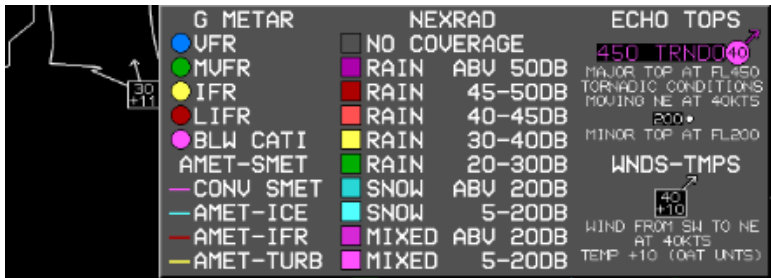


Figure 3-143: Datalink Screen Legend

3.28.2. Air Data and Groundspeed

Air data and groundspeed is displayed in the upper left corner of the datalink screen as specified in § 3.15.8.

3.28.3. Clock/Timers/Options



Figure 3-115: Clock/Timers/Options

The following data items are displayed in the upper right corner of the ND:

- 1) **Zulu Time:** As specified in § 3.16.9.

- 2) **Timer:** As specified in § 3.16.9.
- 3) **Datalink Weather Status:** Status of datalink products are displayed as follows:
- 4) **Datalink Temporary Flight Restriction Data Status:** When the Temporary Flight Restriction Data has not been completely downlinked, status is annunciated as “TFR” with an overlying red “X.”
- 5) **Datalink Weather Status:** When the status of NEXRAD radar, graphical METARs and lightning ground strike data are displayed as follows.

Table 3-32: Datalink NEXRAD Radar Status

Condition	Annunciation
NEXRAD Radar Status:	
Never completely downlinked	No annunciation
Downlinked within last 5 minutes and selected for display (weather radar, if installed, deselected from display).	“NXRD ##” drawn in green where ## is age in minutes. NEXRAD Radar shown on display.
Downlinked within last 5 minutes and deselected from display or weather radar, if installed, has been selected for display.	“NXRD ##” drawn in green where ## is age in minutes. “NXRD ##” overlaid with green “X” NEXRAD Radar not shown on display.
Not downlinked within last 5 minutes but downlinked within last 10 minutes and selected for display (weather radar, if installed, deselected from display).	“NXRD ##” drawn in amber (yellow) where ## is age in minutes. NEXRAD Radar shown on display.

Table 3-32: Datalink NEXRAD Radar Status

Condition	Annunciation
Not downlinked within last 5 minutes but downlinked within last 10 minutes and deselected from display or weather radar, if installed, has been selected for display.	“NXRD ##” drawn in amber (yellow) where ## is age in minutes. “NXRD ##” overlaid with green “X” NEXRAD Radar not shown on display.
Not downlinked within last 10 minutes but downlinked within last 75 minutes and selected for display (weather radar, if installed, deselected from display).	“NXRD ##” drawn in red where ## is age in minutes. NEXRAD Radar shown on display.
Not downlinked within last 10 minutes but downlinked within last 75 minutes and deselected from display or weather radar, if installed, has been selected for display.	“NXRD ##” drawn in red where ## is age in minutes. “NXRD ##” overlaid with green “X” NEXRAD Radar not shown on display.
Not downlinked within last 75 minutes (timed-out)	“NXRD XX” drawn in red “NXRD XX” overlaid with red “X” NEXRAD Radar not shown on display.
Graphical METAR Status:	
Never completely downlinked	No annunciation
Downlinked within last 5 minutes and selected for display	“GMTR ##” drawn in green where ## is age in minutes. Graphical METARs shown on display.

Table 3-32: Datalink NEXRAD Radar Status

Condition	Annunciation
Downlinked within last 5 minutes and deselected from display	<p>“GMTR ##” drawn in green where ## is age in minutes.</p> <p>“GMTR ##” overlaid with green “X”</p> <p>Graphical METARs not shown on display.</p>
Not downlinked within last 5 minutes but downlinked within last 10 minutes and selected for display	<p>“GMTR ##” drawn in amber (yellow) where ## is age in minutes.</p> <p>Graphical METARs shown on display.</p>
Not downlinked within last 5 minutes but downlinked within last 10 minutes and deselected from display	<p>“GMTR ##” drawn in amber (yellow) where ## is age in minutes.</p> <p>“GMTR ##” overlaid with green “X”</p> <p>Graphical METARs not shown on display.</p>
Not downlinked within last 10 minutes but downlinked within last 75 minutes and selected for display	<p>“GMTR ##” drawn in red where ## is age in minutes.</p> <p>Graphical METARs shown on display.</p>
Not downlinked within last 10 minutes but downlinked within last 75 minutes and deselected from display	<p>“GMTR ##” drawn in red where ## is age in minutes.</p> <p>“GMTR ##” overlaid with green “X”</p> <p>Graphical METARs not shown on display.</p>
Not downlinked within last 75 minutes (timed-out)	<p>“GMTR XX” drawn in red</p> <p>“GMTR XX” overlaid with red “X”</p> <p>Graphical METARs not shown on display.</p>
Lightning Ground Strike Status:	
Never completely downlinked	No annunciation

Table 3-32: Datalink NEXRAD Radar Status

Condition	Annunciation
Downlinked within last 5 minutes and selected for display	"LTNG ##" drawn in green where ## is age in minutes. Lightning Ground Strikes shown on display.
Downlinked within last 5 minutes and deselected from display	"LTNG ##" drawn in green where ## is age in minutes. "LTNG ##" overlaid with green "X" Lightning Ground Strikes not shown on display.
Not downlinked within last 5 minutes but downlinked within last 10 minutes and selected for display	"LTNG ##" drawn in amber (yellow) where ## is age in minutes. Lightning Ground Strikes shown on display.
Not downlinked within last 5 minutes but downlinked within last 10 minutes and deselected from display	"LTNG ##" drawn in amber (yellow) where ## is age in minutes. "LTNG ##" overlaid with green "X" Lightning Ground Strikes not shown on display.
Not downlinked within last 10 minutes but downlinked within last 75 minutes and selected for display	"LTNG ##" drawn in red where ## is age in minutes. Lightning Ground Strikes shown on display.
Not downlinked within last 10 minutes but downlinked within last 75 minutes and deselected from display	"LTNG ##" drawn in red where ## is age in minutes. "LTNG ##" overlaid with green "X" Lightning Ground Strikes not shown on display.
Not downlinked within last 75 minutes (timed-out)	"LTNG XX" drawn in red "LTNG XX" overlaid with red "X" Lightning Ground Strikes not shown on display.

3.28.4. Datalink Screen Orientation

The datalink screen is always displayed in North-up orientation and has a boundary circle instead of a compass rose. DATALINK appears above the boundary circle, and, if not in pan mode, the ownship symbol aligns with aircraft heading.

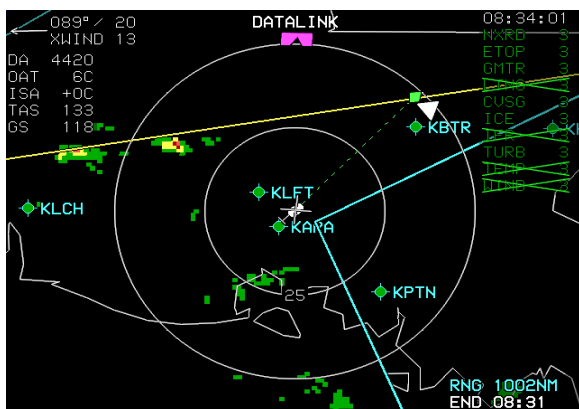


Figure 3-144: Datalink

3.28.5. Datalink Screen Range

When selected the following datalink screen ranges are available as follows.

Table 3-33: Datalink Screen Range Values	
Distance from the ownship to the boundary circle	Radius range values
50 NM	25 NM
100 NM	50 NM
200 NM	100 NM
400 NM	200 NM
800 NM	400 NM
1,600 NM	800 NM

3.28.6. Boundary Circle Symbol



Figure 3-145: Boundary Circle Symbol

A white triangular heading pointer aligned with the longitudinal axis of the ownship symbol appears on the boundary circle with a green diamond-shaped track pointer aligned with the aircraft's track across the earth. A green dashed lubber line connects the center of the aircraft symbol and track pointer. If a target or VNAV altitude is set and not captured, an altitude capture predictor arc is displayed on the lubber line at a point corresponding with predicted climb or descent distance (based upon current VSI). A top of descent symbol is shown as specified in § 3.27.3; however this is not displayed when groundspeed is less than 30 knots. A pilot-settable heading bug geometrically interacting with the heading pointer appears on the boundary circle. A magenta, star-shaped waypoint pointer is displayed on the boundary circle at a point corresponding with the active waypoint. The waypoint pointer turns amber (yellow) in the event of GPS Loss of Navigation caution.

NOTE:

Boundary circle symbols are not drawn, if the datalink screen is in pan mode.

3.28.7. Active Flight Plan Path/Manual Course/Runways

When there is an active flight plan and the GPS/SBAS OBS setting is automatic, the flight plan path is selected and shown on the datalink screen in correct relationship to the ownship symbol. The active flight plan path depiction meets all the requirements of GPS/SBAS path definition and matches the lateral navigation guidance given on the PFD (GPS/SBAS CDI in automatic OBS mode, skyway boxes, and mini-map). Active flight plan path waypoint symbols for fly-over waypoints are distinct from fly-by

waypoints and consist of the waypoint symbol within a circle. When there is a parallel offset, the active flight plan path depicts the parallel offset path and the original flight plan path with haloed gray dashed lines.

When there is an active waypoint and the GPS/SBAS OBS setting is manual, the manual course through the waypoint is shown as a pointer centered on the waypoint. The pointer matches the lateral navigation guidance given on the PFD (GPS/SBAS CDI in manual OBS mode, skyway boxes, and mini-map).

The active flight plan path's active leg/manual course and active waypoint are magenta and turn amber (yellow) in the event of a GPS Loss of Navigation caution.

The datalink screen displays airport runways in their correct relationship and scale to the ownship symbol as specified in § 3.20.

3.28.8. Borders

National and United States state borders are drawn in white in their correct relationship to the ownship symbol.

3.28.9. Pan Mode

The datalink screen has a pan mode to allow the pilot to change the location of the center of the screen away from current location. The pan mode allows the pilot to view weather conditions along the route of flight and at the intended destination or alternate destination. When pan mode is active, press appropriate button(s) to move the pan mode location North, South, East, and West. When pan mode is active, a line from the map center to the aircraft's current position is drawn. When pan mode is active, bearing and distance to the map center are always displayed above the ownship symbol when the aircraft is more than 0.5 NM away. If referenced to magnetic North, (as specified in § 3.16.1) when panning, the nearest displayed graphical METAR symbol within the inner range ring becomes highlighted with a flashing circle. When such a point is highlighted, dedicated menu tiles are present to allow the pilot to view and hide the waypoint information (including datalink weather information) associated with that point.

3.29. Hover Screen

The hover screen has the following elements.

3.29.1. Ownship Symbol

Rotorcraft

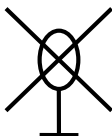
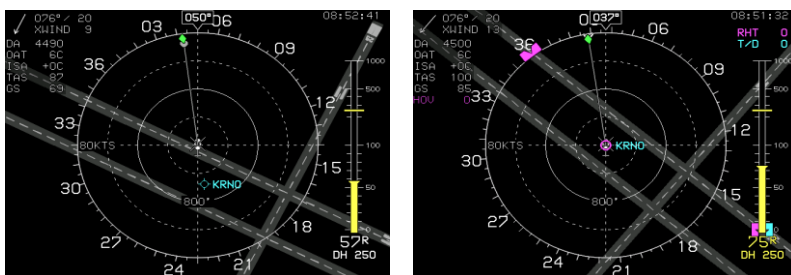


Figure 3-146: Ownship Symbol

3.29.2. Hover Screen Orientation



Other Rotorcraft

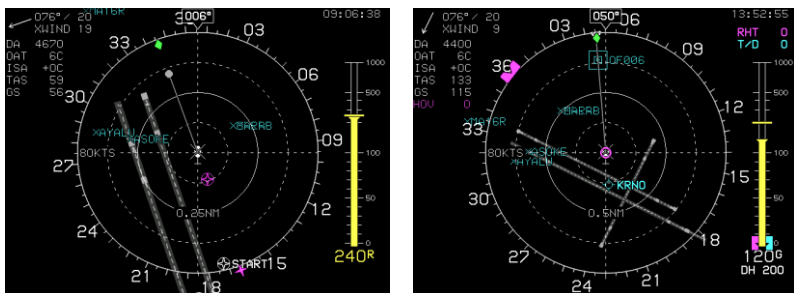
(AW-109SP)

Figure 3-147: ND (Hover Vector Screen)

3.29.3. Hover Screen Range

The following selectable hover screen ranges are available (all distances represent the distance from the ownship symbol to the compass rose): 400', 800', 1,600', 0.5NM, 1NM, 2NM, and 5NM. Two range rings (one at half the radius of the compass rose) centered upon the ownship symbol aid the pilot to judge range to displayed symbols. A range indication corresponding to the radius of the range ring is presented on the range ring (200', 400', 800', 0.25NM, 0.5NM, 1NM, and 2.5NM).

3.29.4. Hover Vector



Other Rotorcraft

(AW-109SP)

Figure 3-148: Hover Vector Symbolology

The hover vector is used to indicate flight direction and groundspeed and re-uses the compass rose and range ring as speed scales. In addition, two intermediate speed scales (the first between the ownship symbol and the range ring, the second between the range ring and the compass rose) are drawn using dashed lines. The speed range for the hover vector indication automatically changes based upon current groundspeed. Available speed ranges are (all speeds represent the speed indicated at the compass rose): 20KTS, 40KTS, and 80KTS with the currently selected speed range textually displayed adjacent to the compass rose. Changes in speed range employ a deadband to prevent flicker at speed range boundaries.

The ownship symbol indicates 0 knots groundspeed and a dot connected to the ownship symbol by a gray line floating over the hover screen to indicate flight direction and groundspeed. Deviation of the dot in a straight up direction (12 o'clock position) indicates forward flight while straight down (6 o'clock position) indicates rearward flight. Deviation of the dot laterally indicates lateral drift. The movement of the dot is constrained to less than five knots per second to prevent jumpiness. The hover vector line and dot are limited and cropped at the outer circle of the hover screen.

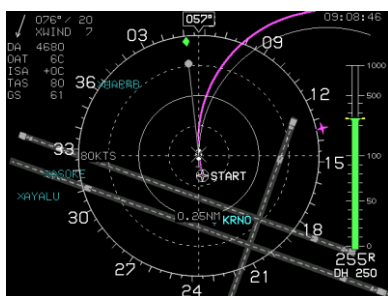
3.29.5. Compass Rose Symbols



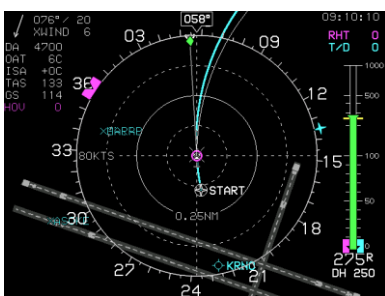
Figure 3-149: ND (Hover Vector Compass Rose)

A digital magnetic heading readout and pointer aligned with the longitudinal axis of the ownship symbol appears on the compass rose boundary circle. A green diamond-shaped track pointer aligned with the aircraft's track across the earth appears on the compass rose when groundspeed is greater than or equal to 30 knots. A pilot-settable heading bug geometrically interacting with the heading pointer appears on the compass rose. A magenta, star-shaped waypoint pointer is displayed on the heading scale at a point corresponding with the active waypoint which turns amber (yellow) in the event of GPS Loss of Navigation caution.

3.29.6. Active Flight Plan Path/Manual Course



Hover Vector Screen



Hover Vector Screen
(AW-109SP)

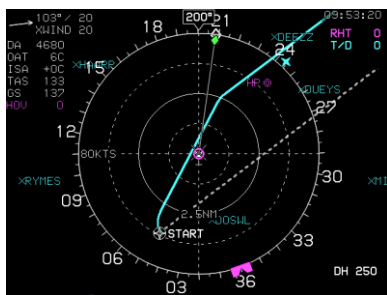
Figure 3-150: ND (Hover Vector Active Flight Plan Path/Manual Course)

When there is an active flight plan and the GPS/SBAS OBS setting is automatic, the flight plan path is shown on the hover screen in its correct relationship to the ownship symbol. The active flight plan path meets all the requirements of GPS/SBAS path definition and matches the lateral navigation guidance given on the PFD (GPS/SBAS CDI in automatic OBS mode, skyway boxes, and mini-map). Active flight plan path waypoints are shown as Fly-over or Fly-by waypoints with the Fly-over waypoint consisting of a waypoint symbol within a circle. The Fly-by waypoint consists of a waypoint symbol without the circle.

When there is a parallel offset, the active flight plan path depicts the parallel offset path, and the original flight plan path is shown with halloed gray lines.



Hover Vector Parallel Track



Hover Vector Parallel Track (AW-109SP)

Figure 3-151: ND (Hover Vector Active Flight Plan Path/Parallel Course)

When there is an active waypoint and the GPS/SBAS OBS setting is manual, the manual course through the waypoint is shown as a pointer centered on the waypoint. The pointer matches the lateral navigation guidance given on the PFD (GPS/SBAS CDI in manual OBS mode, skyway boxes, and mini-map).

The active flight plan path's active leg/manual course and active waypoint are magenta and turn amber (yellow) in the event of a GPS Loss of Navigation caution.

3.29.7. Navigation Data

The hover screen displays navigation data in correct relationship to the ownship symbol. Navigation data symbols include airport symbols, VORs, NDBs, Fixes, and user waypoints. The user waypoint symbol on the hover screen includes an outlining box sized so it cannot be obscured by the ownship symbol. The intent of this requirement is to allow the pilot to hover by reference to a user waypoint. These symbols cannot be decluttered from the Hover Vector screen since there is no **FORMAT..** menu option.

The hover screen displays airport runways in correct relationship and scale to the ownship symbol. Immediately upon a system startup on the ground, the runways for the nearest airport are displayed. Upon activation of a DP, VFR approach, IFR approach, or STAR procedure, the runways for the airport associated with the procedure are displayed. In addition, the runways associated with the three nearest airports are also displayed. Runways are shown

in dark gray according to characteristics contained in the navigation database, including position, orientation, length, and width. The landing portion of the selected runway, taking into account displaced threshold data, are shown in light gray.

3.29.8. Projected Path

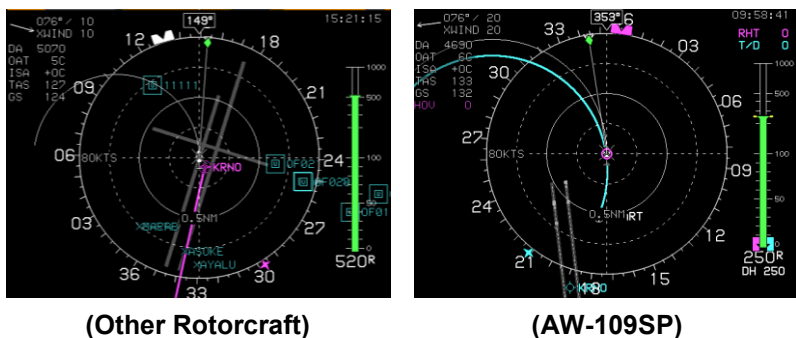


Figure 3-152: ND (Hover Vector Projected Path)

When the aircraft is in a bank angle, a projected path emanates from the ownship symbol. The projected path is based upon aircraft bank angle and groundspeed and projects one minute into the future up to a maximum of 180° of turn.

3.29.9. Air Data and Groundspeed

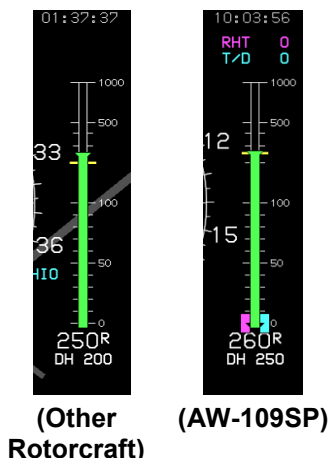
Air data and groundspeed are displayed in the upper left corner of the hover screen as specified in § 3.15.8.

3.29.10. Clock and Timer

The following data items are displayed in the upper right corner of the hover screen:

- 1) **Zulu Time:** Zulu time is shown in hours:minutes:seconds format and synchronized with the GPS/SBAS constellation.
- 2) **Timer:** A countdown timer or count-up timer is displayed when selected by the pilot and match the timer shown on the PFD.

3.29.11. AGL Indication



AGL altitude is displayed as an analog indication and digital readout on the right side of the hover screen, which is driven by whatever AGL altitude source being used as follows:

R = radar altitude.

G = GPS/SBAS geodetic height less database ground elevation.

B = barometric altitude less database ground elevation.

Figure 3-153: ND (Hover Vector AGL Indication)

The digital readout of AGL altitude is not displayed when it is greater than the radar altimeter maximum valid altitude nor when it is invalid. The digital readout of AGL altitude is not displayed when its source is barometric and indicated airspeed is in the noise range (less than 20 KIAS) due to rotor wash effects. When AGL altitude source is radar altitude, the digital readout of AGL indication is smoothed to avoid jumpiness.

Table 3-34: AGL Indication Designed Behavior to Avoid Jumpiness

Altitude	300 Feet	≥ 100 Feet < 300Feet	<100 Feet
AGL Indication resolution	10 Feet	5 Feet	1 Foot

Table 3-35: Analog AGL Indication Designed Parameters

Range of Altitude	Markings	Notes
0-1000'	Green-filled column	Thermometer fashioned style. Top of the column has a widened area for better registration against the scale accordingly, so the widened area disappears at AGL altitudes greater than 1,000 feet (i.e., maximum analog indication).
Scaling		
0 to 100'	Linear	0' AGL is at the bottom, 50' AGL is at 25% of height, 100' AGL is at 50% of height, 200' AGL is at 67% of height, 500' AGL is at 83% of height and 1,000' AGL is at full height
100'-1,000'	Logarithmic	
Major Tick Marks		
0', 50', 100', 500', and 1,000'		
Minor Tick Marks		
10', 20', 30', 40', 60', 70', 80', 90', 200', 300', and 400'		
The color-filled column is not displayed when AGL altitude is invalid. Analog indication of AGL altitude (including the scale) is not displayed, when its source is barometric and indicated airspeed is in the noise range (less than 20 KIAS) due to rotor wash effects.		

3.29.12. Decision Height Indication

The AGL indication may include a display of the currently set decision height altitude as text with the digital indication and as an amber (yellow) bar across the analog indication scale. The textual display of decision height turns amber (yellow) and flashes, and the color-fill of the analog indication of AGL altitude turns amber (yellow) when the aircraft descends below decision height from above. This is accompanied by a “Decision Height” aural annunciation.

3.29.13. Hover Screen (AW-109SP)

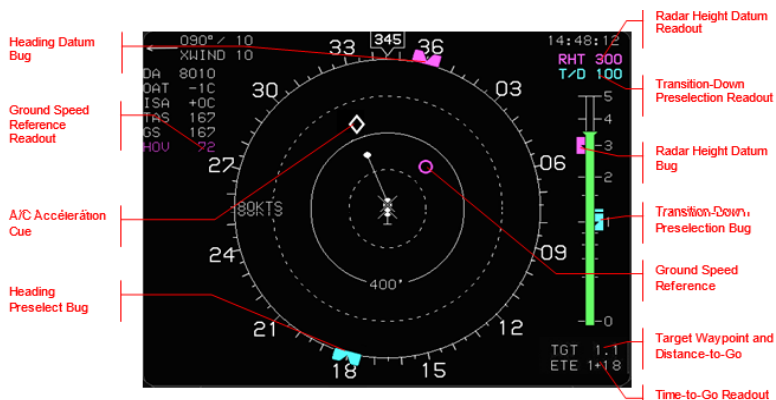


Figure 3-154: Hover Screen (AW-109SP)

3.29.14. Compass Rose Symbols (AW-109SP)

The Compass Rose has a Heading Datum Bug and Heading Preselect Bug shaped to geometrically interact with the present heading pointer symbol. The Heading Datum Bug is filled-magenta, and the Heading Preselect Bug is filled-cyan. When the two bugs overlap, the Heading Datum Bug is drawn on top of the Heading Preselect Bug. The AFCS communicates the Heading Preselect and Datum Bug values to the EFIS. The color of the star-shaped active waypoint pointer is determined using Table 3-10.

3.30. Hover Vector (AW-109SP)

3.30.1. Groundspeed Reference (AW-109SP)

The Groundspeed Reference is an unfilled circle originating from the ownship symbol scaled according to the current groundspeed scale of the Hover Page. The Groundspeed Reference value is derived from the longitudinal and lateral components from the AFCS.

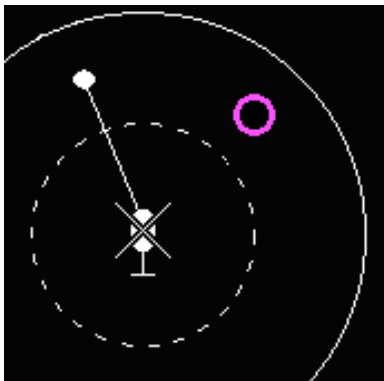
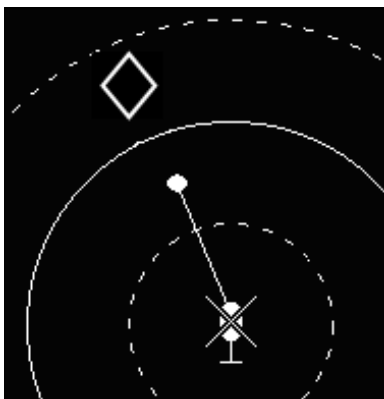


Figure 3-155: Groundspeed Reference (AW-109SP)

The Groundspeed Reference symbol is limited and cropped at the outer circle of the HSI. The color discrete determines whether the Groundspeed Reference Bug is displayed in magenta or cyan.

3.30.2. A/C Acceleration Cue (AW-109SP)



The A/C Acceleration Cue is an unfilled white diamond indicating the normalized Lateral and Longitudinal Acceleration. This symbol originates from the end of the hover vector and is independent of the current scale of the Hover Page.

The input range is -1 to 1 and full scale (1) corresponds to the number of pixels from the center to the outer ring of the display. The A/C Acceleration Cue is

limited and cropped at the outer circle of the HSI. The A/C Acceleration is derived from the longitudinal and lateral components supplied by the AFCS.

Figure 3-156: A/C Acceleration Cue (AW-109SP)

3.30.3. Active Flight Plan Path (AW-109SP)

The color of the active leg in the flight plan path is determined using Table 3-10.

NOTE:

When a MOT flight pattern is being displayed, the active leg includes all legs between the “From” and “To” waypoint.

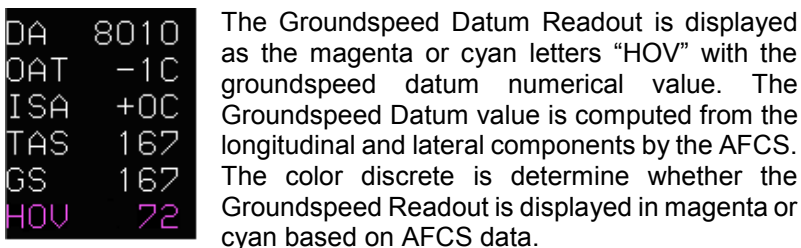
3.30.4. Air Data and Groundspeed (AW-109SP)

Figure 3-157: Air Data and Groundspeed (AW-109SP)

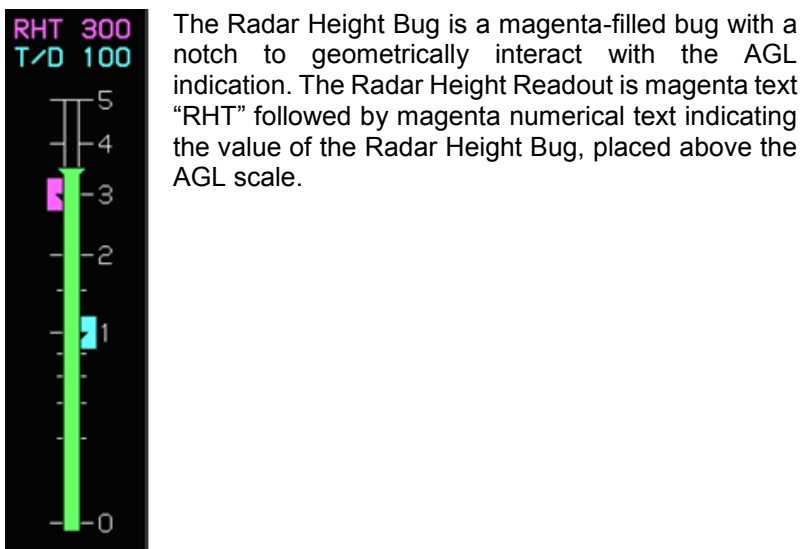

3.30.5. AGL Indication

Figure 3-158: Radar Height Bug and Readout (AW-109SP)

3.30.6. Transition-Down Pre-Selection Bug and Readout (AW-109SP)

The Transition-Down Pre-selection Bug is a cyan-filled bug with a notch to geometrically interact with the AGL indication. The Transition-Down Pre-selection Readout is cyan text “T/D” followed by cyan numerical text indicating the value of the Transition-Down Pre-selection Bug placed above the AGL scale.

3.30.7. Identifier, Distance, and Time to MOT Waypoint (AW-109SP)



The MOT waypoint ID and distance to MOT waypoint is displayed in the lower right of the display in white text. Time to MOT waypoint is displayed below the ID and distance formatted as white letters “ETE” and minutes + seconds.

Figure 3-159: Identifier, Distance, and Time to MOT Waypoint (AW-109SP)

3.30.8. Nav Log Screen (AW-109SP)

14:35:55		FUEL INFO NA				
GS 132						
WAYPOINT	UNAU/OFFSET	PATH	DIST	ETE	ETA	FUEL
KCLL	2300' / --- _{NET}	B+ 283°	3.1 _{NET}	0+01	--:--	-----
CLL	3000' / --- _{NET}	B+ 318°	15.0 _{NET}	0+06	--:--	-----
*GASEC	3000' / --- _{NET}	B+ 321°	61.9 _{NET}	0+28	14:40	-----
ACT	3000' / --- _{NET}	B+ 320°	74.4 _{NET}	0+33	15:08	-----
MOP	3000' / --- _{NET}	B+ 352°	1.6 _{NET}	0+00	15:42	-----
CUTIS	3000' / --- _{NET}	-DISCONT-	0.0 _{NET}	0+00	15:43	-----
CUTIS	2500' / --- _{NET}	B+ 311°	4.6 _{NET}	0+02	15:43	-----
RW31	1026' / --- _{NET}	309° 1500'	0.0 _{NET}	0+00	15:45	-----
MOP	1500' / --- _{NET}	B+ 116°	5.9 _{NET}	0+02	15:45	-----
MOP	3000' / --- _{NET}	309°	12.4 _{NET}	0+05	15:48	-----
(KMWL)	-----' / --- _{NET}	-----	----- _{NET}	--+--	--:--	-----

Figure 3-160: NAV LOG (AW-109SP)

The current active waypoint is the Lateral Navigation color as defined in Table 3-10.

3.31. PFD and MFD Screen Requirements (AW-109SP)

3.31.1. Hover Vector (AW-109SP)

The Groundspeed value used for hover vector indication on both MFD and PFD screens is derived from across and along heading velocity. If data from AFCS is not available or invalid, GPS groundspeed and track are used for hover vector indication.

3.32. Weather Radar

Weather Radar automatically declutters when weather radar returns are selected for display on the ND map screen in correct relationship to the ownship symbol unless inhibited during active FLTA alerts. When Weather Radar is selected for display, datalink NEXRAD is automatically deselected. The following table defines all inhibited factors with display.

Table 3-36: Weather Radar Inhibited Conditions

During Active FLTA alerts
ND Moving Map Panning Mode
When North Up orientation is selected
When RDR-2100 is in vertical profile mode
When screen range is too small to effectively show the weather returns (defined as when the length of the weather radar scan line is longer than 512 pixels given current weather radar scale setting, screen range and screen mode)



Figure 3-161: Weather Radar Image on ND

3.32.1. Weather Screen Format

In a horizontal depiction, the weather screen uses an arced format with the ownship symbol centered in the bottom of the display with the weather area depicted as an arc ahead of the ownship symbol.

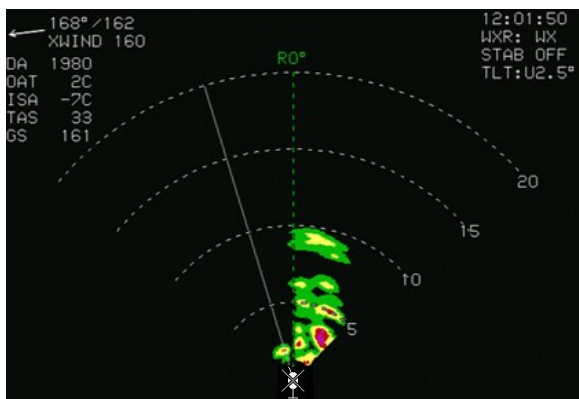


Figure 3-162: Radar Image in Arced Format

In a profile depiction, the weather screen uses an arced format with the ownship symbol centered on the left side of the display and the weather area depicted as an arc to the right of the ownship symbol.

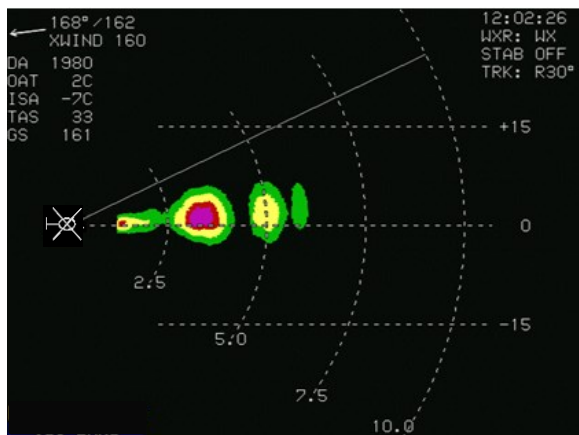


Figure 3-163: Radar Image in Profile Depiction

Pilot selection of the profile depiction is performed using a separate Weather Radar Control Panel connected to the IDU. The IDU ensures at least one weather radar-enabled screen is showing the weather radar page prior to entering into the profile depiction and automatically disables profile depiction, if the pilot sets up the screens so no weather radar page is shown on any weather radar-enabled screen. The purpose of this is to maximize the availability of weather radar information on the ND screen. The ND screen only shows a horizontal depiction and automatically disables profile depiction if the weather radar mode is set to off or standby via Radar Control Panel.

3.32.2. Weather Screen Range

Weather screen range is pilot-selectable through either ① (RDR-2000 and RDR-2100 weather radar types) or a control panel directly attached to the weather radar receiver-transmitter. Weather screen range is displayed as a series of equidistant dashed arcs centered upon the ownship symbol to help the pilot judge range to the displayed weather radar returns.

All distances represent the distance from the ownship symbol to the outer dashed arc: 5NM, 10NM, 20NM, 40NM, 80NM, 160NM, 240NM, and 320NM.

For most screen ranges, there are four equidistant dashed arcs. When in 2.5NM range, there are five equidistant dashed arcs. Each arc labeled with distance in nautical miles at its right-most point (horizontal depiction) or bottom-most point (profile depiction). In the profile depiction mode, there are also three horizontal altitude lines drawn relative to the aircraft's altitude to help the pilot judge the vertical distance to the displayed weather radar returns. The center line is level with the ownship symbol to represent the aircraft's altitude. The other two lines are equally spaced above and below the center line to represent altitude differences above and below the aircraft. The number of feet above and below the aircraft varies with the selected range to compensate for the radar scan width at the different ranges.

3.32.3. Track Line

When the weather radar type is RDR-2000 or RDR-2100 and the horizontal depiction is shown, a dashed track line appears emanating from the ownship symbol to the outer dashed arc. The value of the track line in whole degrees left or right of aircraft heading is displayed adjacent to the outer end of the track line.

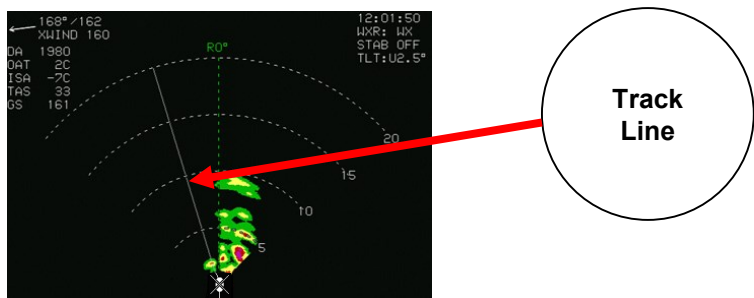


Figure 3-164: Radar Track Line

3.32.4. Active Flight Plan Path/Manual Course/Runways

The active flight plan path (when selected), waypoints, and manual course appear as specified in § 3.29.6 when the weather radar screen showing horizontal depiction.

The weather radar screen displays airport runways as specified in § 3.20 when the weather radar screen is showing horizontal depiction.

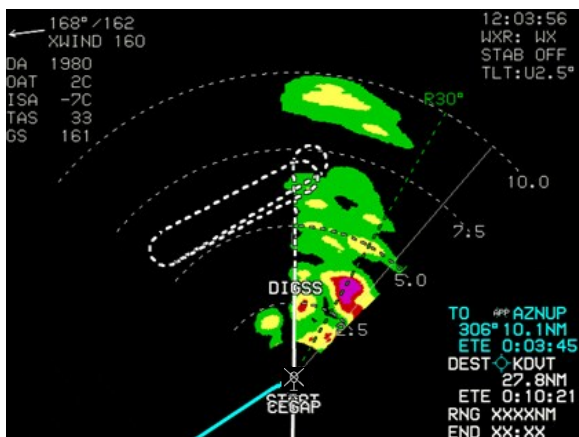


Figure 3-165: Radar Active Flight Plan

Weather radar data is displayed as colored regions according to the value found in Table 3-37.

3.32.5. Weather Radar Return Data

Weather radar return data are displayed on the weather radar screen in its correct relationship to the ownship symbol.

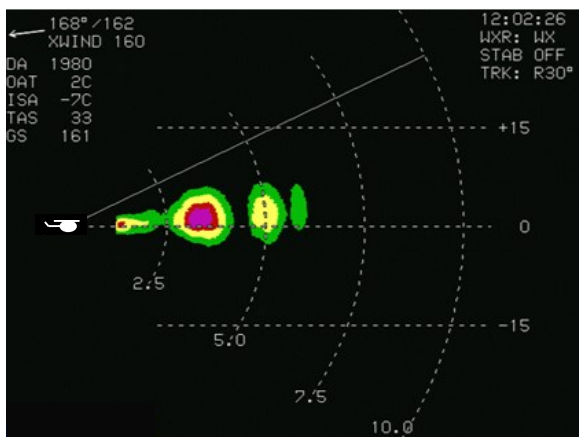


Figure 3-166: Radar Return Data

Weather radar return data is displayed as colored regions according to the value of the ARINC 453 3-bit range bins as follows.

Table 3-37: Weather Radar Return Data

ARINC 453 3-Bit Range Bin	Color	Meaning
000b	BLACK	No Returns
001b	GREEN	Low-Level Weather or Low-Level Ground Returns
010b	AMBER (YELLOW)	Mid-Level Weather or Mid-Level Ground Returns
011b	RED	Third-Level Weather Returns. This color is replaced with BLACK when in MAP mode. MAP mode is encoded in ARINC 453 label 055 and 171 bits 27-29 as 010b.
100b	MAGENTA	Fourth-Level Weather or Third-Level Ground Returns. With an RDR-2000 or RDR-2100 weather radar type, this color alternates between MAGENTA and BLACK at 1Hz when the internal submode is WXA.
101b	CYAN	Automatic Range Limit Returns. Indicates areas of unreliable returns due to radar power absorption
110b	LIGHT GRAY	Moderate Turbulence Returns
111b	WHITE	Severe Turbulence Returns

The following weather radar-specific warning appears in a conspicuous area adjacent to the weather radar return data so they do not conflict with the weather radar return data. Only one weather radar-specific warning appears at any given time with the following order of precedence:

- 1) **WX ALRT:** Weather alert condition is active. A weather alert condition is indicated according to weather radar type as follows:

- | | |
|-----------------------------|---|
| a) ARINC 708-6: | ARINC 453 label 055 Bit 15 |
| b) Collins 800/840: | ARINC 453 label 055 Bit 15 |
| c) Honeywell Primus: | ARINC 453 label 055 Bit 12 |
| d) Honeywell RDR-2000/2100: | ARINC 453 label 055 or label 171 Bit 20 |
- 2) **TURB ALERT:** Turbulence alert condition is active. A turbulence alert condition is indicated by ARINC 453 label 055 Bit 14. (Honeywell Primus and Honeywell RDR-2000/2100 do not set this bit.)
 - 3) **STAB LIMIT:** Aircraft attitude has moved to a point where the weather radar antenna can no longer be effectively stabilized. A stability limit condition is indicated by ARINC 453 label 055 or label 171 Bit 18.
 - 4) **ANT FAULT:** Weather radar antenna is temporarily dislodged by turbulence.

3.32.6. Air Data and Groundspeed

Air data and groundspeed is displayed in the upper left corner of the weather radar screen as specified in § 3.15.8.

3.32.7. Clock/Timers/Options



Figure 3-167: Radar Clock/Timer/Options

- 1) Zulu Time: Information displayed as specified in § 3.16.9;
- 2) Timer: Countdown or count-up timer as specified in § 3.16.9;
- 3) Weather Radar Mode Annunciation is as follows.

Table 3-38: RDR 2100 Applicability

Mode	Annunciation
Off	WXR:OFF
Standby	WXR:STBY
Weather Only	WXR:WX
Weather Alert	WXR:WXA
Ground Map	WXR:GMAP
Contour	WXR:CONT
Test	WXR:TEST
Not Defined	WXR:----

Table 3-39: RDR 2100 Mode Annunciation

Annunciation	Conditions
Overlaid with Red X	Weather Radar Mode is off or not defined. A Cooling Fault Condition exists. An Attitude or Range Fault Condition exists. A Control Fault Condition exists. A T/R Fault Condition exists. A Control Fault Condition exists. A T/R Fault Condition exists.
STAB OFF (Stabilization)	Weather radar mode annunciation is not overlaid with a red "X"; Weather radar mode is not standby or forced standby; and Weather radar indicates stabilization is off.

Table 3-39: RDR 2100 Mode Annunciation

Annunciation	Conditions
TGT ALERT (Target Alert)	<p>The weather radar mode annunciation is not overlaid with a red “X”;</p> <p>The weather radar mode is not standby or forced standby;</p> <p>The weather radar is presenting the horizontal depiction;</p>
TLT:UXX.X” or “TLT:AUTO (TILT)	<p>U = Up or Down (either U or D, but not both, may appear – use U for 0°);</p> <p>XX.X represents the absolute value of the tilt angle in degrees truncated to the nearest tenth;</p> <p>TLT:AUTO is used where the weather radar reports a value of -16°, representing automatic tilt.</p> <p>The weather radar tilt annunciation only appears when all of the following conditions are true:</p> <p>The weather radar mode annunciation is not overlaid with a red “X”;</p> <p>The weather radar mode is not standby or forced standby; and</p> <p>The weather radar is not in Vertical Profile submode.</p>

Table 3-39: RDR 2100 Mode Annunciation

Annunciation	Conditions
<p>TRK:LXX (TRACK)</p>	<p>L = Left or Right (either L or R, but not both, may appear – use “R” for 0°); and</p> <p>XX represents the absolute value of the track angle in degrees.</p> <p>The weather radar track annunciation only appears when all of the following conditions are true:</p> <p>The weather radar mode annunciation is not overlaid with a red “X”;</p> <p>The weather radar mode is not standby or forced standby; and</p> <p>The weather radar is in Vertical Profile submode (profile depiction).</p>
<p>“GN:SXXDB,” “GN:CAL” or “GN:MAX” (GAIN)</p>	<p>S = Sign (either “+” or “-”, but not both, may appear – use “+” for 0°); and</p> <p>XXDB represents the manual gain setting in decibels.</p> <p>“GN:CAL” represents the calibrated condition</p> <p>“GN:MAX” represents maximum manual gain</p> <p>The weather radar manual gain annunciation only appears when all of the following conditions are true:</p> <p>The weather radar mode annunciation is not overlaid with a red “X”;</p> <p>The weather radar mode is not standby or forced standby; and</p> <p>The weather radar mode is Ground Map.</p>

3.32.8. Fuel Totalizer/Waypoint Bearing and Distance Functions

Fuel totalizer, waypoint bearing, and waypoint distance are displayed in the lower right corner of the weather radar screen as specified in § 3.16.8.

3.33. Video Input Screen

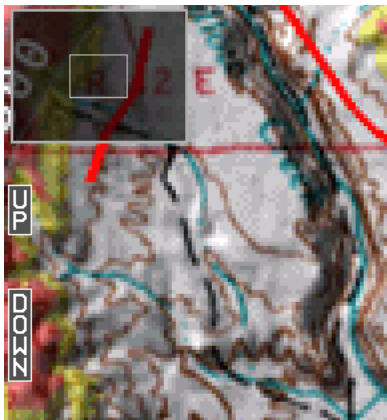
The video input screen is an image of 640 by 480 pixels and accepts video input signals in the RS-170 composite format. The system is configurable to the NTSC, PAL (including the PAL-m and PAL-nc variants) or SECAM versions of RS-170 separately for each video input. In addition, auto-detection mode, which programs the video input chip to process most standard RS-170 formats, is configurable for each video input.

- 1) **NO VIDEO IMAGE AVAILABLE:** When no video signal is detected, the video input screen is black with the annunciation displayed in white centered on the screen. To aid in diagnosing problems with undetected video signals, the following annunciations are displayed below this annunciation in white centered on the screen.
- 2) **NO INTERLACED SIGNAL:** No interlaced signal detected.
- 3) **NO HORIZ OR VERT SYNC:** No horizontal or vertical synchronization detected.
- 4) **NO COLOR SIGNAL:** No video chroma signal detected.
- 5) **LOAD ERROR DETECTED:** Video chip reports a load error.
- 6) **TRIGGER ERROR DETECTED:** Video chip reports a trigger error.
- 7) **PROGRAMMING ERROR DETECTED:** Video chip reports a programming error.

3.33.1. ZOOM Level

The pilot may zoom the video image by replicating pixels to a desired ZOOM levels from 1 (no pixel replication) to 10 in increments of one.

3.33.2. Pan Mode



When the ZOOM level is greater than one, the Video Input screen has a pan mode to allow the pilot to select the portion of the video image displayed by replicating pixels. When pan mode is active, controls are present to allow moving the portion displayed Up, Down, Left, and Right.

Figure 3-168: Video Pan View

A mini-map of the displayed image's position in the full video image is displayed for ten seconds after:

- 1) Entering pan mode,
- 2) Changing the ZOOM level to a value greater than 1,
- 3) Panning the zoomed image.

Exiting the pan mode removes the pan mode controls and the mini-map, if any.

3.33.3. Video Input Status Display

When selected by the pilot, the following data items are optionally displayed in the upper right corner of the Video Input display.

Label: Identifies the video input source and is configurable to one of a set of predefined labels. If no label is configured, the label is "VIDEO-n" where 'n' is the video input source number.

ZOOM: Amount of pixel expansion is displayed as "ZOOM nnX" where 'nn' is the ZOOM level.

Brightness: Video brightness setting is displayed and formatted as "BRT nnn%" where 'nnn' is the brightness setting as a percentage of the maximum value.

Contrast: Video contrast setting is displayed and formatted as “**CTRST nnn%**” where ‘**nnn**’ is the contrast setting as a percentage of the maximum value.

Saturation: Video chroma saturation setting is displayed and formatted as “**SAT nnn%**” where ‘**nnn**’ is the saturation setting as a percentage of the maximum value.

Hue: Video chroma hue setting is displayed and formatted as “**HUE nnn%**” where ‘**nnn**’ is the hue setting as a percentage of the maximum value.



Figure 3-169: Video Status

Section 4 Reversionary Modes

Table of Contents

SECTION 4	REVERSIONARY MODES	4-1
4.1.	REVERSIONARY MODES	4-5
4.2.	SYSTEM OPERATION IN REVERSIONARY MODES	4-6
4.2.1.	<i>Oat Sensor Failure Mode</i>	4-9
4.2.2.	<i>Heading Failure Mode</i>	4-10
4.2.3.	<i>PFD Screen Auto Reversion</i>	4-10
4.2.4.	<i>GPS Failure</i>	4-10
4.3.	PFD FAILURE MODE 0	4-13
4.3.1.	<i>MFD Failure Mode 0 (Normal Mode)</i>	4-14
4.4.	PFD FAILURE MODE 1	4-16
4.4.1.	<i>MFD Failure Mode 1</i>	4-17
4.5.	PFD FAILURE MODE 2 (NORMAL MODE)	4-19
4.5.1.	<i>MFD Failure Mode 2</i>	4-20
4.6.	PFD FAILURE MODE 3	4-22
4.6.1.	<i>MFD Failure Mode 3</i>	4-23
4.7.	PFD FAILURE MODE 4	4-25
4.7.1.	<i>MFD Failure Mode 4</i>	4-26
4.8.	PFD FAILURE MODE 5	4-28
4.8.1.	<i>MFD Failure Mode 5</i>	4-29
4.9.	PFD FAILURE MODE 6	4-31
4.9.1.	<i>MFD Failure Mode 6</i>	4-32
4.10.	PFD FAILURE MODE 7	4-34
4.10.1.	<i>MFD Failure Mode 7</i>	4-35

List of Figures and Tables

Table 4-1: Reversionary Mode Status (PFD)	4-6
Table 4-2: Reversionary Mode Status (ND)	4-7
Table 4-3: Reversionary Mode Status (Output Functions).....	4-7
Figure 4-1: FAULTS Page on MFD	4-11
Figure 4-2: PFD Failure Mode 0 GPS, ADC, and AHRS Normal.....	4-13
Table 4-4: PFD Failure Mode 0 GPS, ADC, and AHRS Normal	4-13
Figure 4-3: MFD Failure Mode 0 GPS, ADC, and AHRS Normal	4-14
Table 4-5: MFD Failure Mode 0 GPS, ADC, and AHRS Normal	4-15
Figure 4-4: PFD Failure Mode 1 GPS/SBAS Failed; ADC and AHRS Normal	4-16
Table 4-6: PFD Failure Mode 1 GPS/SBAS Failed; ADC and AHRS Normal	4-16
Figure 4-5: MFD Failure Mode 1 GPS/SBAS Failed; ADC and AHRS Normal	4-17
Table 4-7: MFD Failure Mode 1 GPS/SBAS Failed; ADC and AHRS Normal	4-18
Figure 4-6: PFD Mode 2 ADC Failed; GPS/SBAS and AHRS Normal	4-19
Table 4-8: PFD Mode 2 ADC Failed; GPS/SBAS and AHRS Normal	4-19
Figure 4-7: MFD Failure Mode 2, ADC Failed; GPS/SBAS and AHRS Normal	4-20
Table 4-9: MFD Failure Mode 2, ADC Failed; GPS/SBAS and AHRS Normal	4-21
Figure 4-8: PFD Failure Mode 3 AHRS Failed; GPS/SBAS and ADC Normal	4-22
Table 4-10: PFD Failure Mode 3 AHRS Failed, GPS/SBAS and ADC Normal	4-22
Figure 4-9: MFD Failure Mode 3 AHRS Failed; GPS/SBAS and ADC Normal	4-23
Table 4-11: MFD Failure Mode 3 AHRS Failed; GPS/SBAS and ADC Normal	4-24
Figure 4-10: PFD Failure Mode 4 GPS/SBAS and ADC Failed; AHRS Normal	4-25
Table 4-12: PFD Failure Mode 4 GPS/SBAS and ADC Failed; AHRS Normal	4-25
Figure 4-11: MFD Failure Mode 4 GPS/SBAS and ADC Failed; AHRS Normal	4-26
Table 4-13: MFD Failure Mode 4 GPS/SBAS and ADC Failed; AHRS Normal	4-27

Figure 4-12: PFD Failure Mode 5 GPS/SBAS and AHRS Failed; ADC Normal	4-28
Table 4-14: PFD Failure Mode 5 GPS/SBAS and AHRS Failed; ADC Normal	4-28
Figure 4-13: MFD Failure Mode 5 GPS/SBAS and AHRS Failed; ADC Normal	4-29
Table 4-15: MFD Failure Mode 5 GPS/SBAS and AHRS Failed; ADC Normal	4-30
Figure 4-14: PFD Failure Mode 6 ADC and AHRS Failed; GPS/SBAS Normal	4-31
Table 4-16: PFD Failure Mode 6 ADC and AHRS Failed; GPS/SBAS Normal	4-31
Figure 4-15: MFD Failure Mode 6 ADC and AHRS Failed; GPS/SBAS Normal	4-32
Table 4-17: MFD Failure Mode 6 ADC and AHRS Failed; GPS/SBAS Normal	4-33
Figure 4-16: PFD Failure Mode 7 GPS/SBAS, ADC, and AHRS Failed	4-34
Table 4-18: PFD Failure Mode 7 GPS/SBAS, ADC, and AHRS Failed	4-34
Figure 4-17: MFD Failure Mode 7 GPS/SBAS, ADC, and AHRS Failed	4-35
Table 4-19: MFD Failure Mode 7 GPS/SBAS, ADC, and AHRS Failed	4-36

4.1. Reversionary Modes

The equipment has eight reversionary modes as follows:

Mode 0: GPS/SBAS, ADC, and AHRS normal.

Mode 1: GPS/SBAS failed; ADC and AHRS normal.

Mode 2: ADC failed; GPS/SBAS, and AHRS normal.

Mode 3: AHRS failed; GPS/SBAS, and ADC normal.

Mode 4: GPS/SBAS and ADC failed; and AHRS normal.

Mode 5: GPS/SBAS and AHRS failed; and ADC normal.

Mode 6: ADC and AHRS failed; and GPS/SBAS normal.

Mode 7: GPS, ADC, and AHRS failed.

To use this section, review the following table and notes to determine what feature or function is affected by one or more of the three sensors failed conditions. Examples follow with the IDU-450 displays in various configurations with a table breaking down the affected functions.

Not all possible IDU-450 display configurations and format combinations are represented here. All eight modes of System Operation are represented for description purposes.

4.2. System Operation in Reversionary Modes

Table 4-1: Reversionary Mode Status (PFD)

PFD Functions	Mode							
	0	1	2	3	4	5	6	7
Airspeed	OK	OK	19	OK	19	OK	19	19
Altimeter	OK	OK	19	OK	19	OK	19	19
Altimeter Set Display	OK	OK	-	OK	-	OK	-	-
Bank Scale	OK	OK	OK	-	OK	-	-	-
CDI	OK	1 + 20	OK	OK	20	20	OK	20
Runway	OK	1	-	-	-	-	-	-
Waypoint Pointer	7	1	7	7	-	-	7	-
Heading Scale	7	7	7	7	7	-	7	-
AGL Ind.	OK	2	4	OK	11	11	4	-
Flight Path Marker	OK	1 + 14	-	-	-	-	-	-
Hover Vector	OK	-	-	-	-	-	-	-
Ground Track	7	1	7	7	-	-	7	-
Heading Indicator	7	7	7	-	7	-	-	-
Horizon	OK	OK	OK	-	OK	-	-	-
Mini-Map	7	1	7	7	-	-	7	-
Pitch Scale	OK	OK	OK	-	OK	-	-	-
Highway in the Sky	OK	1 + 15	-	-	-	-	-	-
Terrain/Obstructions	OK	-	-	-	-	-	-	-
Clock Functions	OK	OK	OK	OK	OK	OK	OK	OK
VSI	OK	OK	-	OK	-	OK	-	-
Waterline Symbol	22	22	5	13	5	13	13	13
Waypoint Symbol	OK	1	-	-	-	-	-	-
Waypoint Brg/Dist	OK	1	OK	OK	-	-	OK	-
Traffic	OK	OK	OK	-	-	-	-	-
Traffic Thumbnail	OK	OK	OK	OK	OK	OK	OK	OK
Speed Trend	OK	OK	-	-	-	-	-	-

Table 4-2: Reversionary Mode Status (ND)

ND Functions	Mode							
	0	1	2	3	4	5	6	7
Aircraft Position	OK	1	OK	OK	-	-	OK	-
Special Use Airspace	9	1	6	9	-	-	6 + 9	-
Waypoint Pointer	9	1	9	9	-	-	9	-
Active Flight Plan Path	9	1	9	9	-	-	9	-
Glide Range	9	1	-	10	-	-	-	-
Groundspeed	OK	1	OK	OK	-	-	OK	-
Ground Track	9	1	9	9	-	-	9	-
Heading Indicator	9	9	9	-	9	-	-	-
Navigation Symbols	9	1	9	9	-	-	9	-
Outside Air Temp.	OK	OK	-	OK	-	OK	-	-
Projected Path	OK	1	OK	-	-	-	-	-
Traffic	OK	OK	OK	OK	OK	OK	OK	OK
Terrain/Obstructions	OK	-	-	OK	-	-	-	-
Clock Functions	OK	OK	OK	OK	OK	OK	OK	OK
Waypoint Brg./Dist.	OK	1	OK	OK	-	-	OK	-
Wind	21	3	-	-	-	-	-	-
WX-500 Data	OK	OK	OK	OK	OK	OK	OK	OK
Compass Rose	9	9	9	9	9	-	9	-
Fuel Totalizer Functions	23	24	23	23	12	12	12	12
True Airspeed	OK	OK	-	OK	-	OK	-	-
Density Altitude	OK	OK	-	OK	-	OK	-	-
OAT/ISA Display	OK	OK	-	OK	-	OK	-	-

Table 4-3: Reversionary Mode Status (Output Functions)

Output Functions	Mode							
	0	1	2	3	4	5	6	7
Air/Ground Output	16	16	17	16	17	16	17	17
Autopilot EFIS Valid	16	16	16	-	-	-	-	-
TAWS Alarm Output	16	16	16	16	16	16	16	16
TCAS-II RA Display Valid	16	16	-	16	-	16	-	-
TCAS-II TA Display Valid	16	16	16	16	16	16	16	16
Transmit Enabled	16	16	16	16	16	16	16	16
Warning Light Output	16	16	16	16	16	16	16	16
Caution Light Output	16	16	16	16	16	16	16	16
Mstr. Caut. Light Output	16	16	16	16	16	16	16	16
MDA/DH Output	16	16	18	16	18	16	18	18

Table 4-3: Reversionary Mode Status (Output Functions)

Output Functions	Mode							
	0	1	2	3	4	5	6	7
Altitude Capture Output	16	16	-	16	-	16	-	-
IAS Switch Output	16	16	-	16	-	16	-	-

- Note 1: Presented using inertial dead-reckoning based on last known wind information. If unable to dead-reckon (e.g., heading is failed or true airspeed cannot be calculated), function is disabled.
- Note 2: Only radar altitude presented when available.
- Note 3: Last known wind is saved during GPS/SBAS failure.
- Note 4: Either radar altitude or geodetic altitude less database elevation.
- Note 5: Waterline symbol expanded to large attitude bars. Rotorcraft versions (Part 27 or Part 29 airspeed scale), use full-time large attitude bars and do not show the waterline symbol.
- Note 6: Special use airspace boundaries are drawn with bold lines due to lack of aircraft altitude data.
- Note 7: In heading-only failure mode or AHRS failure mode, heading scale aligned with aircraft track and heading indication is removed. In heading-only failure mode or AHRS failure mode combined with GPS failure, heading scale is replaced with a Red-X.
- Note 9: In heading-only failure mode or AHRS failure mode, compass rose aligned with aircraft track and heading indication is removed when in heading up mode. In heading-only failure mode or AHRS failure mode combined with GPS failure, compass rose is removed.
- Note 10: Presents using last-known wind information and aligned with aircraft track in heading up mode.
- Note 11: Only radar altitude presented when available.

- Note 12: Assuming valid fuel flow information, endurance is presented.
- Note 13: Large attitude bars presented and X'd out.
- Note 14: Flight Path Marker grayed after 1 minute to indicate degraded operation.
- Note 15: Highway in the Sky removed after 1 minute.
- Note 16: See IDU SCC Card and Limits Requirements for activation requirements.
- Note 17: Defaults to AIR unless Weight on Wheel/Weight on Ground discrete input is active.
- Note 18: Only DH function (with valid AGL altitude) in this mode.
- Note 19: Red-X in place of scale.
- Note 20: VLOC CDI always available if optional VOR symbology enabled.
- Note 21: Function removed during heading-only failure mode.
- Note 22: Rotorcraft versions (Part 27 or Part 29 airspeed scale), use full-time large attitude bars and do not show the waterline symbol.
- Note 23: Assuming valid fuel flow information, both range and endurance are presented.
- Note 24: Assuming valid fuel flow information, both range and endurance are presented using inertial dead-reckoning based on last known wind information. If the pilot is unable to dead-reckon due to loss of heading or true airspeed cannot be calculated, endurance only information is presented.

4.2.1. Oat Sensor Failure Mode

In addition, the equipment has an OAT sensor failure mode. With the OAT sensor failed, the display of wind, OAT, density altitude, and true airspeed on the ND are disabled.

4.2.2. Heading Failure Mode

In addition, the equipment has a heading failure mode. With heading failed, the PFD heading scale and MFD compass rose aligns with track (if available) or is removed and replaced with a Red-X. In this failure mode, the PFD heading scale includes the nomenclature “GPS TRK” around the track marker to clearly delineate the failure mode.

4.2.3. PFD Screen Auto Reversion

For IFR approval in aircraft, flight instrument information essential to safety of flight remains available to the pilot without additional crewmember action after a failure. To accommodate this, MFDs must have the ability to sense when the PFD has failed and take over the PFD function automatically. The manner in which this occurs on the IDU-450 is as follows.

4.2.4. GPS Failure

GPS degrades or fails as a result of loss of satellite information, or GPS equipment failure. When the integrity is provided by SBAS, the IDU provides a LOI (Loss of Integrity) monitoring caution within two seconds, if the current HPL (Horizontal Protection Level) exceeds the HAL (Horizontal Alert Level). This LOI caution appears when there is no integrity monitoring and disappears when integrity monitoring is restored.

Further GPS degradation causes the EFIS to lose GPS updating of aircraft position, groundspeed, and ground track, and the ability to calculate the wind information.

- 1) **GPS LOI** (Loss of Integrity) displayed with no time delay.
- 2) HPL > HAL for the phase of flight currently in. Position is still presented based upon a GPS navigation solution.
- 3) **GPS LON** (Loss of Navigation) displayed with no time delay of the onset of the following:
 - a) The absence of power;
 - b) Equipment malfunction or failure;

- c) The presence of a condition lasting five seconds or more where there are an inadequate number of satellites to compute position solution;
- d) Fault detects a position failure that cannot be excluded within time-to-alert when integrity is provided by FDE;
- e) HPL > HAL on the final approach segment. Genesys Aerosystems EFIS does not transition to DR Navigation at this stage. A GPS Navigation solution is still presented; and
- f) Where HPL > HAL on the final approach segment, this position may still be satisfactory for GPS Navigation. For example, an HPL of 0.31NM exists which means as soon as a transition to TERMINAL mode occurs, all alerts would disappear. This is significantly important during a wind change, if the system had been in a DR mode.

NOTE:

At any time, the pilot may view HFOM on the FAULTS page to see the system-reported accuracy.



Figure 4-1: FAULTS Page on MFD

1) **DR** (Dead Reckoning)

DR 00:00
DR 01:23

In the event a GPS position cannot be calculated, a dead reckoning solution is

provided with a timer. This solution is calculated from Heading and TAS derived from the AHRS and ADC.

- a) **NO POSITION**, no position available from the GPS and the EFIS cannot DR due to a second failure.

2) **VERT LON** (Loss of Vertical Navigation)

In the event the navigation equipment is no longer adequate to conduct or continue the LNAV/VNAV approach, **VERT LON** appears within one second of the onset of any of the following conditions:

- a) The absence of power;
- b) Equipment malfunction or failure;
- c) The presence of a condition where fault detection detects a position failure that cannot be excluded;
- d) There are an insufficient number of SBAS HEALTHY satellites;
- e) The horizontal protection level exceeds the alert limit as follows for LNAV/VNAV approaches:
 - i) Prior to sequencing the FAWP- HAL should be 0.3 NM with no limit on VAL
 - ii) After sequencing the FAWP- HAL 556m (0.3NM) and VAL 50m

When in LNAV mode, the fault detection function detects positioning failures within 10 seconds after the onset of the positioning failure.

GPS failure results in the EFIS operating in “dead reckoning” mode. The EFIS continues to provide navigational position, groundspeed, and ground track information, based upon the last known wind, current air data, and heading. The IDU-450 PFD and MFD are affected as follows.

4.3. PFD Failure Mode 0

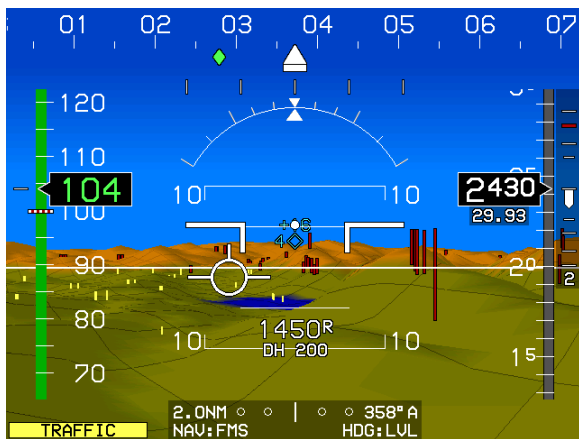


Figure 4-2: PFD Failure Mode 0 GPS, ADC, and AHRS Normal

Table 4-4: PFD Failure Mode 0 GPS, ADC, and AHRS Normal

PFD Functions	Mode 0	ND Functions	Mode 0
Airspeed	OK	Aircraft Position	OK
Altimeter	OK	Special Use Airspace	9
Altimeter Set Display	OK	Waypoint Pointer	9
Bank Scale	OK	Active Flight Plan Path	9
CDI	OK	WX-500	OK
Runway	OK	Groundspeed	OK
Waypoint Pointer	7	Ground Track	9
Heading Scale	7	Heading Indicator	9
AGL Ind.	OK	Navigation Symbols	9
Flight Path Marker	OK	Outside Air Temp	OK
Hover Vector	OK	Projected Path	OK
Ground Track	7	Traffic	OK
Heading Indicator	7	Terrain/Obstructions	OK
Horizon	OK	Clock Functions	OK

Table 4-4: PFD Failure Mode 0 GPS, ADC, and AHRS Normal

PFD Functions	Mode 0	ND Functions	Mode 0
Mini-Map	7	Waypoint Brg./Dist.	OK
Pitch Scale	OK	Wind	21
Highway in the Sky	OK	Compass Rose	9
Terrain/Obstruction	OK	Fuel Totalizer	23
Clock Functions	OK	True Airspeed	OK
VSI	OK	Density Altitude	OK
Waterline Symbol	22	OAT/ISA Display	OK
Waypoint Symbol	OK	WX 500 Data	OK
Waypoint Brg./Dist.	OK		
Traffic	OK		
Traffic Thumbnail	OK		
Speed Trend	OK		

4.3.1. MFD Failure Mode 0 (Normal Mode)


Figure 4-3: MFD Failure Mode 0 GPS, ADC, and AHRS Normal

Table 4-5: MFD Failure Mode 0 GPS, ADC, and AHRS Normal

PFD Functions	Mode 0	ND Functions	Mode 0
Airspeed	OK	Aircraft Position	OK
Altimeter	OK	Special Use Airspace	9
Altimeter Set Display	OK	Waypoint Pointer	9
Bank Scale	OK	Active Flight Plan Path	9
CDI	OK		
WX-500	OK	Groundspeed	OK
Waypoint Pointer	7	Ground Track	9
Heading Scale	7	Heading Indicator	9
AGL Ind.	OK	Navigation Symbols	9
Flight Path Marker	OK	Outside Air Temp	OK
Hover Vector	OK	Projected Path	OK
Ground Track	7	Traffic	OK
Heading Indicator	7	Terrain/Obstructions	OK
Horizon	OK	Clock Functions	OK
Mini-Map	7	Waypoint Brg./Dist.	OK
Pitch Scale	OK	Wind	21
Highway in the Sky	OK	Compass Rose	9
Terrain/Obstruction	OK	Fuel Totalizer	23
Clock Functions	OK	True Airspeed	OK
VSI	OK	Density Altitude	OK
Waterline Symbol	22	OAT/ISA Display	OK
Waypoint Symbol	OK	WX 500 Data	OK
Waypoint Brg./Dist.	OK		
Traffic	OK		
Traffic Thumbnail	OK		
Speed Trend	OK		

4.4. PFD Failure Mode 1

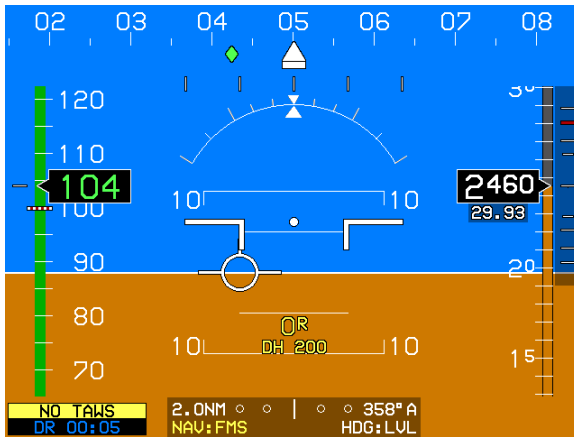


Figure 4-4: PFD Failure Mode 1 GPS/SBAS Failed; ADC and AHS Normal

Table 4-6: PFD Failure Mode 1 GPS/SBAS Failed; ADC and AHS Normal

PFD Functions	Mode 1	ND Functions	Mode 1
Airspeed	OK	Aircraft Position	1
Altimeter	OK	Special Use Airspace	1
Altimeter Set Display	OK	Waypoint Pointer	1
Bank Scale	OK	Active Flight Plan Path	1
CDI	1 + 20		
Runway	1	Groundspeed	1
Waypoint Pointer	1	Ground Track	1
Heading Scale	7	Heading Indicator	9
AGL Ind.	2	Navigation Symbols	1
Flight Path Marker	1 + 14	Outside Air Temp	OK
Hover Vector	-	Projected Path	1
Ground Track	1	Traffic	OK
Heading Indicator	7	Terrain/Obstructions	-

Table 4-6: PFD Failure Mode 1 GPS/SBAS Failed; ADC and AHRS Normal

PFD Functions	Mode 1	ND Functions	Mode 1
Horizon	OK	Clock Functions	OK
Mini-Map	1	Waypoint Brg./Dist.	1
Pitch Scale	OK	Wind	3
Highway in the Sky	1 + 15	Compass Rose	9
Terrain/Obstruction	-	Fuel Totalizer	24
Clock Functions	OK	True Airspeed	OK
VSI	OK	Density Altitude	OK
Waterline Symbol	22	OAT/ISA Display	OK
Waypoint Symbol	1	WX-500	OK
Waypoint Brg./Dist.	1		
Traffic	OK		
Traffic Thumbnail	OK		
Speed Trend	OK		

4.4.1. MFD Failure Mode 1



Figure 4-5: MFD Failure Mode 1 GPS/SBAS Failed; ADC and AHRS Normal

Table 4-7: MFD Failure Mode 1 GPS/SBAS Failed; ADC and AHRS Normal

PFD Functions	Mode 1	ND Functions	Mode 1
Airspeed	OK	Aircraft Position	1
Altimeter	OK	Special Use Airspace	1
Altimeter Set Display	OK	Waypoint Pointer	1
Bank Scale	OK	Active Flight Plan Path	1
CDI	1 + 20	Groundspeed	1
Runway	1	Ground Track	1
Waypoint Pointer	1	Heading Indicator	9
Heading Scale	7	Navigation Symbols	1
AGL Ind.	2	Outside Air Temp	OK
Flight Path Marker	1 + 14	Projected Path	1
Hover Vector	-	Traffic	OK
Ground Track	1	Terrain/Obstructions	-
Heading Indicator	7	Clock Functions	OK
Horizon	OK	Waypoint Brg./Dist.	1
Mini-Map	1	Wind	3
Pitch Scale	OK	Compass Rose	9
Highway in the Sky	1 + 15	Fuel Totalizer	24
Terrain/Obstruction	-	True Airspeed	OK
Clock Functions	OK	Density Altitude	OK
VSI	OK	OAT/ISA Display	OK
Waterline Symbol	22	WX-500	OK
Waypoint Symbol	1		
Waypoint Brg./Dist.	1		
Traffic	OK		
Traffic Thumbnail	OK		
Speed Trend	OK		

4.5. PFD Failure Mode 2 (Normal Mode)

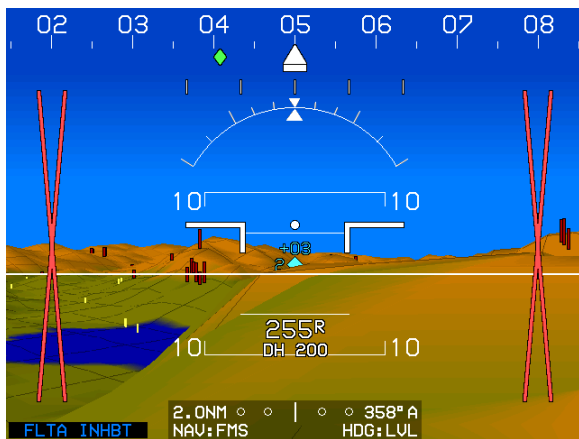


Figure 4-6: PFD Mode 2 ADC Failed; GPS/SBAS and AHRS Normal

Table 4-8: PFD Mode 2 ADC Failed; GPS/SBAS and AHRS Normal

PFD Functions	Mode 2	ND Functions	Mode 2
Airspeed	19	Aircraft Position	OK
Altimeter	19	Special Use Airspace	6
Altimeter Set Display	-	Waypoint Pointer	9
Bank Scale	OK	Active Flight Plan Path	9
CDI	OK	Groundspeed	OK
Runway	-	Ground Track	9
Waypoint Pointer	7	Heading Indicator	9
Heading Scale	7	Navigation Symbols	9
AGL Ind.	4	Outside Air Temp	-
Flight Path Marker	-	Projected Path	OK
Hover Vector	-	Traffic	OK
Ground Track	7	Terrain/Obstructions	-

Table 4-8: PFD Mode 2 ADC Failed; GPS/SBAS and AHRS Normal

PFD Functions	Mode 2	ND Functions	Mode 2
Heading Indicator	7	Clock Functions	OK
Horizon	OK	Waypoint Brg./Dist.	OK
Mini-Map	7	Wind	-
Pitch Scale	OK	Compass Rose	9
Highway in the Sky	-	Fuel Totalizer	23
Terrain/Obstruction	-	True Airspeed	-
Clock Functions	OK	Density Altitude	-
VSI	-	OAT/ISA Display	-
Waterline Symbol	5	WX-500	OK
Waypoint Symbol	-		
Waypoint Brg./Dist.	OK		
Traffic	OK		
Traffic Thumbnail	OK		
Speed Trend	-		

4.5.1. MFD Failure Mode 2

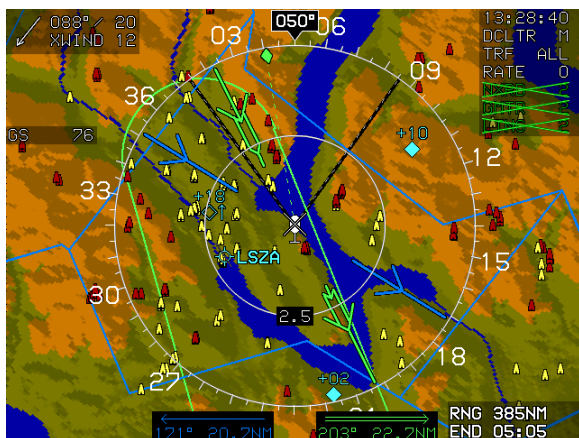

Figure 4-7: MFD Failure Mode 2, ADC Failed; GPS/SBAS and AHRS Normal

Table 4-9: MFD Failure Mode 2, ADC Failed; GPS/SBAS and AHRS Normal

PFD Functions	Mode 2	ND Functions	Mode 2
Airspeed	19	Aircraft Position	OK
Altimeter	19	Special Use Airspace	6
Altimeter Set Display	-	Waypoint Pointer	9
Bank Scale	OK	Active Flight Plan Path	9
CDI	OK	Groundspeed	OK
Runway	-	Ground Track	9
Waypoint Pointer	7	Heading Indicator	9
Heading Scale	7	Navigation Symbols	9
AGL Ind.	4	Outside Air Temp	-
Flight Path Marker	-	Projected Path	OK
Hover Vector	-	Traffic	OK
Ground Track	7	Terrain/Obstructions	-
Heading Indicator	7	Clock Functions	OK
Horizon	OK	Waypoint Brg./Dist.	OK
Mini-Map	7	Wind	-
Pitch Scale	OK	Compass Rose	9
Highway in the Sky	-	Fuel Totalizer	23
Terrain/Obstruction	-	True Airspeed	-
Clock Functions	OK	Density Altitude	-
VSI	-	OAT/ISA Display	-
Waterline Symbol	5	WX-500	OK
Waypoint Symbol	-		
Waypoint Brg./Dist.	OK		
Traffic	OK		
Traffic Thumbnail	OK		
Speed Trend	-		

4.6. PFD Failure Mode 3

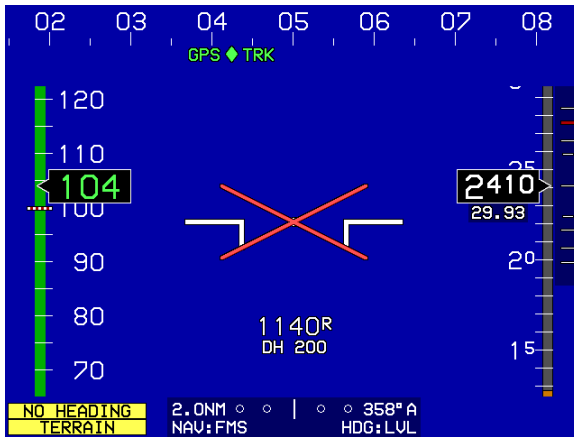


Figure 4-8: PFD Failure Mode 3 AHRS Failed; GPS/SBAS and ADC Normal

Table 4-10: PFD Failure Mode 3 AHRS Failed, GPS/SBAS and ADC Normal

PFD Functions	Mode 3	ND Functions	Mode 3
Airspeed	OK	Aircraft Position	OK
Altimeter	OK	Special Use Airspace	9
Altimeter Set Display	OK	Waypoint Pointer	9
Bank Scale	-	Active Flight Plan Path	9
CDI	OK	Groundspeed	OK
Runway	-	Ground Track	9
Waypoint Pointer	7	Heading Indicator	-
Heading Scale	7	Navigation Symbols	9
AGL Ind.	OK	Outside Air Temp	OK
Flight Path Marker	-	Projected Path	-
Hover Vector	-	Traffic	OK
Ground Track	7	Terrain/Obstructions	OK

Table 4-10: PFD Failure Mode 3 AHRS Failed, GPS/SBAS and ADC Normal

PFD Functions	Mode 3	ND Functions	Mode 3
Heading Indicator	-	Clock Functions	OK
Horizon	-	Waypoint Brg./Dist.	OK
Mini-Map	7	Wind	-
Pitch Scale	-	Compass Rose	9
Highway in the Sky	-	Fuel Totalizer	23
Terrain/Obstruction	-	True Airspeed	OK
Clock Functions	OK	Density Altitude	OK
VSI	OK	OAT/ISA Display	OK
Waterline Symbol	13	WX-500	OK
Waypoint Symbol	-		
Waypoint Brg./Dist.	OK		
Traffic	-		
Traffic Thumbnail	OK		
Speed Trend	-		

4.6.1. MFD Failure Mode 3



Figure 4-9: MFD Failure Mode 3 AHRS Failed; GPS/SBAS and ADC Normal

Table 4-11: MFD Failure Mode 3 AHRS Failed; GPS/SBAS and ADC Normal

PFD Functions	Mode 3	ND Functions	Mode 3
Airspeed	OK	Aircraft Position	OK
Altimeter	OK	Special Use Airspace	9
Altimeter Set Display	OK	Waypoint Pointer	9
Bank Scale	-	Active Flight Plan Path	9
CDI	OK	Groundspeed	OK
Runway	-	Ground Track	9
Waypoint Pointer	7	Heading Indicator	-
Heading Scale	7	Navigation Symbols	9
AGL Ind.	OK	Outside Air Temp	OK
Flight Path Marker	-	Projected Path	-
Hover Vector	-	Traffic	OK
Ground Track	7	Terrain/Obstructions	OK
Heading Indicator	-	Clock Functions	OK
Horizon	-	Waypoint Brg./Dist.	OK
Mini-Map	7	Wind	-
Pitch Scale	-	Compass Rose	9
Highway in the Sky	-	Fuel Totalizer	23
Terrain/Obstruction	-	True Airspeed	OK
Clock Functions	OK	Density Altitude	OK
VSI	OK	OAT/ISA Display	OK
Waterline Symbol	13	WX-500	OK
Waypoint Symbol	-		
Waypoint Brg./Dist.	OK		
Traffic	-		
Traffic Thumbnail	OK		
Speed Trend	-		

4.7. PFD Failure Mode 4

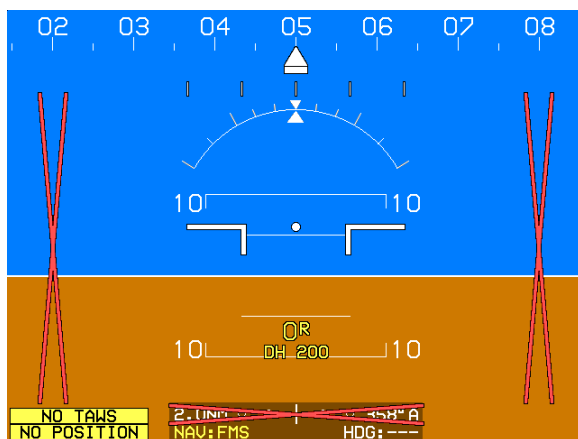


Figure 4-10: PFD Failure Mode 4 GPS/SBAS and ADC Failed; AHRs Normal

Table 4-12: PFD Failure Mode 4 GPS/SBAS and ADC Failed; AHRs Normal

PFD Functions	Mode 4	ND Functions	Mode 4
Airspeed	19	Aircraft Position	-
Altimeter	19	Special Use Airspace	-
Altimeter Set Display	-	Waypoint Pointer	-
Bank Scale	OK	Active Flight Plan Path	-
CDI	20	Groundspeed	-
Runway	-	Ground Track	-
Waypoint Pointer	-	Heading Indicator	9
Heading Scale	7	Navigation Symbols	-
AGL Ind.	11	Outside Air Temp	-
Flight Path Marker	-	Projected Path	-
Hover Vector	-	Traffic	OK
Ground Track	-	Terrain/Obstructions	-

Table 4-12: PFD Failure Mode 4 GPS/SBAS and ADC Failed; AHRS Normal

PFD Functions	Mode 4	ND Functions	Mode 4
Heading Indicator	7	Clock Functions	OK
Horizon	OK	Waypoint Brg./Dist.	-
Mini-Map	-	Wind	-
Pitch Scale	OK	Compass Rose	9
Highway in the Sky	-	Fuel Totalizer	12
Terrain/Obstruction	-	True Airspeed	-
Clock Functions	OK	Density Altitude	-
VSI	-	OAT/ISA Display	-
Waterline Symbol	5	WX-500	OK
Waypoint Symbol	-		
Waypoint Brg./Dist.	-		
Traffic	-		
Traffic Thumbnail	OK		
Speed Trend	-		

4.7.1. MFD Failure Mode 4


Figure 4-11: MFD Failure Mode 4 GPS/SBAS and ADC Failed; AHRS Normal

Table 4-13: MFD Failure Mode 4 GPS/SBAS and ADC Failed; AHRS Normal

PFD Functions	Mode 4	ND Functions	Mode 4
Airspeed	19	Aircraft Position	-
Altimeter	19	Special Use Airspace	-
Altimeter Set Display	-	Waypoint Pointer	-
Bank Scale	OK	Active Flight Plan Path	-
CDI	20	Groundspeed	-
Runway	-	Ground Track	-
Waypoint Pointer	-	Heading Indicator	9
Heading Scale	7	Navigation Symbols	-
AGL Ind.	11	Outside Air Temp	-
Flight Path Marker	-	Projected Path	-
Hover Vector	-	Traffic	OK
Ground Track	-	Terrain/Obstructions	-
Heading Indicator	7	Clock Functions	OK
Horizon	OK	Waypoint Brg./Dist.	-
Mini-Map	-	Wind	-
Pitch Scale	OK	Compass Rose	9
Highway in the Sky	-	Fuel Totalizer	12
Terrain/Obstruction	-	True Airspeed	-
Clock Functions	OK	Density Altitude	-
VSI	-	OAT/ISA Display	-
Waterline Symbol	5	WX-500	OK
Waypoint Symbol	-		
Waypoint Brg./Dist.	-		
Traffic	-		
Traffic Thumbnail	OK		
Speed Trend	-		

4.8. PFD Failure Mode 5

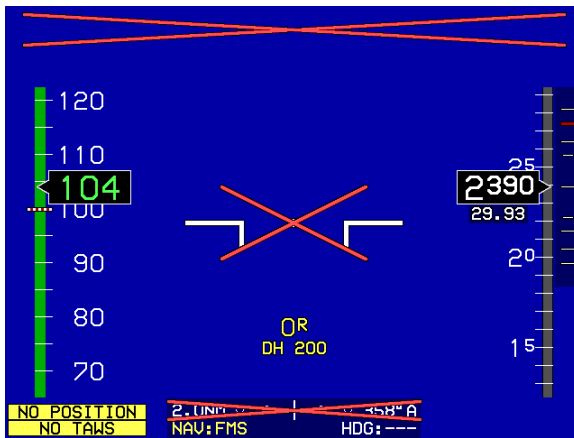


Figure 4-12: PFD Failure Mode 5 GPS/SBAS and AHRS Failed; ADC Normal

PFD Functions	Mode 5	ND Functions	Mode 5
Airspeed	OK	Aircraft Position	-
Altimeter	OK	Special Use Airspace	-
Altimeter Set Display	OK	Waypoint Pointer	-
Bank Scale	-	Active Flight Plan Path	-
CDI	20	Groundspeed	-
Runway	-	Ground Track	-
Waypoint Pointer	-	Heading Indicator	-
Heading Scale	-	Navigation Symbols	-
AGL Ind.	11	Outside Air Temp	OK
Flight Path Marker	-	Projected Path	-
Hover Vector	-	Traffic	OK
Ground Track	-	Terrain/ Obstructions	-

Table 4-14: PFD Failure Mode 5 GPS/SBAS and AHRS Failed; ADC Normal

PFD Functions	Mode 5	ND Functions	Mode 5
Heading Indicator	-	Clock Functions	OK
Horizon	-	Waypoint Brg./Dist.	-
Mini-Map	-	Wind	-
Pitch Scale	-	Compass Rose	-
Highway in the Sky	-	Fuel Totalizer	12
Terrain/Obstruction	-	True Airspeed	-
Clock Functions	OK	Density Altitude	-
VSI	OK	OAT/ISA Display	-
Waterline Symbol	13	WX-500	OK
Waypoint Symbol	-		
Waypoint Brg./Dist.	-		
Traffic	-		
Traffic Thumbnail	OK		
Speed Trend	-		

4.8.1. MFD Failure Mode 5

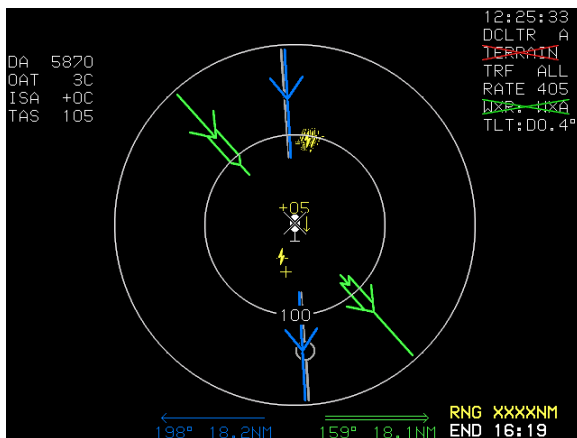


Figure 4-13: MFD Failure Mode 5 GPS/SBAS and AHRS Failed; ADC Normal

Table 4-15: MFD Failure Mode 5 GPS/SBAS and AHRS Failed; ADC Normal

PFD Functions	Mode 5	ND Functions	Mode 5
Airspeed	OK	Aircraft Position	-
Altimeter	OK	Special Use Airspace	-
Altimeter Set Display	OK	Waypoint Pointer	-
Bank Scale	-	Active Flight Plan Path	-
CDI	20	Groundspeed	-
Runway	-	Ground Track	-
Waypoint Pointer	-	Heading Indicator	-
Heading Scale	-	Navigation Symbols	-
AGL Ind.	11	Outside Air Temp	OK
Flight Path Marker	-	Projected Path	-
Hover Vector	-	Traffic	OK
Ground Track	-	Terrain/Obstructions	-
Heading Indicator	-	Clock Functions	OK
Horizon	-	Waypoint Brg./Dist.	-
Mini-Map	-	Wind	-
Pitch Scale	-	Compass Rose	-
Highway in the Sky	-	Fuel Totalizer	12
Terrain/Obstruction	-	True Airspeed	-
Clock Functions	OK	Density Altitude	-
VSI	OK	OAT/ISA Display	-
Waterline Symbol	13	WX-500	OK
Waypoint Symbol	-		
Waypoint Brg./Dist.	-		
Traffic	-		
Traffic Thumbnail	OK		
Speed Trend	-		

4.9. PFD Failure Mode 6

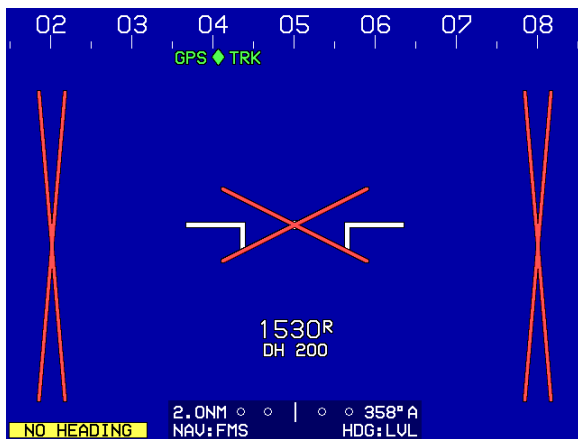


Figure 4-14: PFD Failure Mode 6 ADC and AHRS Failed; GPS/SBAS Normal

Table 4-16: PFD Failure Mode 6 ADC and AHRS Failed; GPS/SBAS Normal

PFD Functions	Mode 6	ND Functions	Mode 6
Airspeed	19	Aircraft Position	OK
Altimeter	19	Special Use Airspace	6 + 9
Altimeter Set Display	-	Waypoint Pointer	9
Bank Scale	-	Active Flight Plan Path	9
CDI	OK	Groundspeed	OK
Runway	-	Ground Track	9
Waypoint Pointer	7	Heading Indicator	-
Heading Scale	7	Navigation Symbols	9
AGL Ind.	4	Outside Air Temp	-
Flight Path Marker	-	Projected Path	-
Hover Vector	-	Traffic	OK
Ground Track	7	Terrain/Obstructions	-

**Table 4-16: PFD Failure Mode 6 ADC and AHRS Failed;
GPS/SBAS Normal**

PFD Functions	Mode 6	ND Functions	Mode 6
Heading Indicator	-	Clock Functions	OK
Horizon	-	Waypoint Brg./Dist.	OK
Mini-Map	7	Wind	-
Pitch Scale	-	Compass Rose	9
Highway in the Sky	-	Fuel Totalizer	12
Terrain/Obstruction	-	True Airspeed	-
Clock Functions	OK	Density Altitude	-
VSI	-	OAT/ISA Display	-
Waterline Symbol	13	WX-500	OK
Waypoint Symbol	-		
Waypoint Brg./Dist.	OK		
Traffic	-		
Traffic Thumbnail	OK		
Speed Trend	-		

4.9.1. MFD Failure Mode 6


**Figure 4-15: MFD Failure Mode 6 ADC and AHRS Failed;
GPS/SBAS Normal**

**Table 4-17: MFD Failure Mode 6 ADC and AHRS Failed;
GPS/SBAS Normal**

PFD Functions	Mode 6	ND Functions	Mode 6
Airspeed	19	Aircraft Position	OK
Altimeter	19	Special Use Airspace	6 + 9
Altimeter Set Display	-	Waypoint Pointer	9
Bank Scale	-	Active Flight Plan Path	9
CDI	OK	Groundspeed	OK
Runway	-	Ground Track	9
Waypoint Pointer	7	Heading Indicator	-
Heading Scale	7	Navigation Symbols	9
AGL Ind.	4	Outside Air Temp	-
Flight Path Marker	-	Projected Path	-
Hover Vector	-	Traffic	OK
Ground Track	7	Terrain/Obstructions	-
Heading Indicator	-	Clock Functions	OK
Horizon	-	Waypoint Brg./Dist.	OK
Mini-Map	7	Wind	-
Pitch Scale	-	Compass Rose	9
Highway in the Sky	-	Fuel Totalizer	12
Terrain/Obstruction	-	True Airspeed	-
Clock Functions	OK	Density Altitude	-
VSI	-	OAT/ISA Display	-
Waterline Symbol	13	WX-500	OK
Waypoint Symbol	-		
Waypoint Brg./Dist.	OK		
Traffic	-		
Traffic Thumbnail	OK		
Speed Trend	-		

4.10. PFD Failure Mode 7

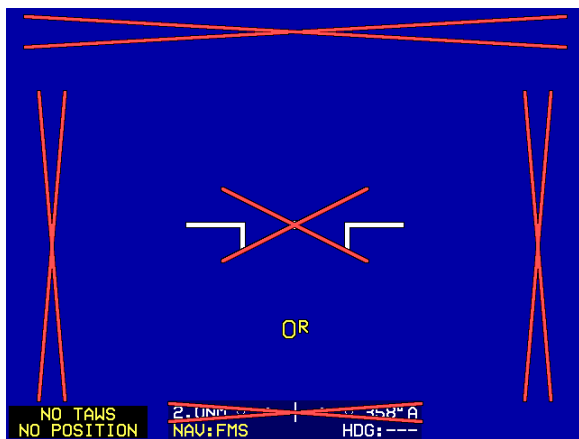


Figure 4-16: PFD Failure Mode 7 GPS/SBAS, ADC, and AHRS Failed

Table 4-18: PFD Failure Mode 7 GPS/SBAS, ADC, and AHRS Failed

PFD Functions	Mode 7	ND Functions	Mode 7
Airspeed	19	Aircraft Position	-
Altimeter	19	Special Use Airspace	-
Altimeter Set Display	-	Waypoint Pointer	-
Bank Scale	-	Active Flight Plan Path	-
CDI	20	Groundspeed	-
Runway	-	Ground Track	-
Waypoint Pointer	-	Heading Indicator	-
Heading Scale	-	Navigation Symbols	-
AGL Ind.	-	Outside Air Temp	-
Flight Path Marker	-	Projected Path	-
Hover Vector	-	Traffic	OK
Ground Track	-	Terrain/Obstructions	-

Table 4-18: PFD Failure Mode 7 GPS/SBAS, ADC, and AHRs Failed			
PFD Functions	Mode 7	ND Functions	Mode 7
Heading Indicator	-	Clock Functions	OK
Horizon	-	Waypoint Brg./Dist.	-
Mini-Map	-	Wind	-
Pitch Scale	-	Compass Rose	-
Highway in the Sky	-	Fuel Totalizer	12
Terrain/Obstruction	-	True Airspeed	-
Clock Functions	OK	Density Altitude	-
VSI	-	OAT/ISA Display	-
Waterline Symbol	13	WX-500	OK
Waypoint Symbol	-		
Waypoint Brg./Dist.	-		
Traffic	-		
Traffic Thumbnail	OK		
Speed Trend	-		

4.10.1. MFD Failure Mode 7

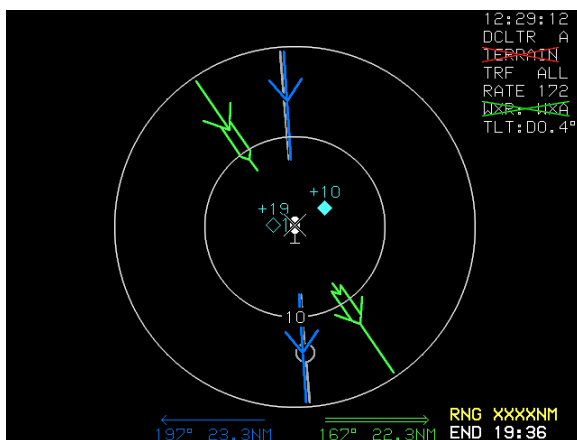


Figure 4-17: MFD Failure Mode 7 GPS/SBAS, ADC, and AHRs Failed

Table 4-19: MFD Failure Mode 7 GPS/SBAS, ADC, and AHRS Failed

PFD Functions	Mode 7	ND Functions	Mode 7
Airspeed	19	Aircraft Position	-
Altimeter	19	Special Use Airspace	-
Altimeter Set Display	-	Waypoint Pointer	-
Bank Scale	-	Active Flight Plan Path	-
CDI	20	Groundspeed	-
Runway	-	Ground Track	-
Waypoint Pointer	-	Heading Indicator	-
Heading Scale	-	Navigation Symbols	-
AGL Ind.	-	Outside Air Temp	-
Flight Path Marker	-	Projected Path	-
Hover Vector	-	Traffic	OK
Ground Track	-	Terrain/Obstructions	-
Heading Indicator	-	Clock Functions	OK
Horizon	-	Waypoint Brg./Dist.	-
Mini-Map	-	Wind	-
Pitch Scale	-	Compass Rose	-
Highway in the Sky	-	Fuel Totalizer	12
Terrain/Obstruction	-	True Airspeed	-
Clock Functions	OK	Density Altitude	-
VSI	-	OAT/ISA Display	-
Waterline Symbol	13	WX-500	OK
Waypoint Symbol	-		
Waypoint Brg./Dist.	-		
Traffic	-		
Traffic Thumbnail	OK		
Speed Trend	-		

Section 5 Menu Functions and Step-By-Step Procedures

Table of Contents

SECTION 5	MENU FUNCTIONS AND	STEP-BY-STEP	
PROCEDURES			5-1
5.1.	MENU FUNCTIONS.....		5-8
5.2.	MENU SYNCHRONIZATION.....		5-8
5.3.	MENU FUNCTION TYPES		5-12
5.4.	TOP-LEVEL MENU		5-13
5.4.1.	<i>IDU-450 PFD Normal Mode Top-Level Menu..</i>		<i>5-13</i>
5.5.	TOP-LEVEL MENU OPTION DESCRIPTIONS.....		5-14
5.5.1.	<i>Top-Level Menu Soft Menu Tiles (AW-109SP)</i>		<i>5-14</i>
5.5.2.	<i>#1 Encoder (I).....</i>		<i>5-14</i>
5.5.3.	<i>Top-Level Menu Automatic Pop-up Function Descriptions.....</i>		<i>5-15</i>
5.6.	FIRST PAGE (PFD)		5-19
5.6.1.	<i>PFD Page First-Level Option Descriptions</i>		<i>5-19</i>
5.6.2.	<i>PFD Screen First Soft Menu Level</i>		<i>5-20</i>
5.6.3.	<i>First-Level (MFD)</i>		<i>5-21</i>
5.7.	LOWER-LEVEL MENUS (BELOW FIRST-LEVEL)		5-22
5.8.	FLIGHT PLAN (FPL) MENU.....		5-23
5.8.1.	<i>Flight Planner Page.....</i>		<i>5-23</i>
5.8.2.	<i>MFD Page Shown on IDU.....</i>		<i>5-24</i>
5.8.3.	<i>To Create an Overfly User Waypoint</i>		<i>5-24</i>
5.8.4.	<i>Flight Plan (FPL) Menu Selecting (Step-By-Step) ..</i>		<i>5-25</i>
5.8.5.	<i>Flight Plan (FPL) Menu Create-Edit (MFD Only) (Step-By-Step).....</i>		<i>5-26</i>
5.8.6.	<i>Activate Flight Plan (MFD Only) (Step-By-Step).....</i>		<i>5-27</i>

5.8.7.	<i>Edit Flight Plan (MFD Only) (Step-By-Step).....</i>	5-28
5.8.8.	<i>Reverse Flight Plan (MFD Only) (Step-By-Step)</i>	5-29
5.8.9.	<i>Delete Flight Plan (MFD Only) (Step-By-Step)</i>	5-30
5.8.10.	<i>Create User Waypoint (LAT-LON) (MFD Only)</i> <i>(Step-By-Step)</i>	5-30
5.8.11.	<i>Create User Waypoint (RAD-DST) (MFD Only)</i> <i>(Step-By-Step)</i>	5-32
5.8.12.	<i>Edit User Waypoint (MFD Only) (Step-By-Step).....</i>	5-33
5.8.13.	<i>Delete User Waypoint (MFD Only) (Step-By-Step).</i>	5-34
5.8.14.	<i>RAIM Prediction.....</i>	5-35
5.9.	ACTIVE FLIGHT PLAN (ACTV) MENU	5-37
5.9.1.	<i>Main Menu.....</i>	5-37
5.9.2.	<i>Active Flight Plan (ACTV) Menu Options</i>	5-42
5.9.3.	<i>Active Flight Plan (ACTV) Menu Options (Step-By-Step)</i>	5-47
5.9.4.	<i>Active Flight Plan (ACTV) Menu (Step-By-Step).....</i>	5-48
5.9.5.	<i>Active Flight Plan (ACTV) Options NRST Menu Option (Step-By-Step)</i>	5-49
5.9.6.	<i>Active Flight Plan (ACTV) Menu (AW-109SP) .</i>	5-49
5.10.	INFORMATION (INFO) MENU	5-50
5.10.1.	<i>Information (INFO) Menu (Step-By-Step).....</i>	5-52
5.10.2.	<i>Information (INFO) Menu (AW-109SP)</i>	5-52
5.11.	OMNIBEARING SELECTOR (OBS) MENU.....	5-53
5.11.1.	<i>Omnibearing Selector (OBS) Menu (Step-By-Step)</i>	5-54

5.11.2.	<i>Omnibearing Selector (OBS) Menu (AW-109SP) ...</i>	5-54
5.12.	HEADING BUG (HDG) MENU.....	5-55
5.12.1.	<i>Heading Bug (HDG) Menu (PFD Only) (Step-By-Step)</i>	5-55
5.12.2.	<i>Heading Bug (HDG) Menu (AW-109SP).....</i>	5-55
5.13.	NEAREST (NRST) MENU.....	5-56
5.13.1.	<i>Nearest (NRST) Menu (Step-By-Step)</i>	5-58
5.13.2.	<i>Nearest ILS (NRST) Menu (Step-By-Step)</i>	5-59
5.14.	DIRECT MENU.....	5-60
5.14.1.	<i>Direct Menu (Step-By-Step).....</i>	5-62
5.15.	TIMER (TIMER) MENU	5-63
5.15.1.	<i>Timer (TIMER) Menu (Step-By-Step)</i>	5-64
5.16.	PFD SOURCE (SOURCE) MENU	5-65
5.16.1.	<i>PFD Page First-Level Source Selection (Step-By-Step)</i>	5-66
5.17.	PFD BUGS (BUGS) MENU (N/A FOR AW-109SP)	5-67
5.17.1.	<i>PFD Bugs (BUGS) Menu (Step-By-Step)</i>	5-70
5.18.	PFD BUGS (BUGS) MENU (AW-109SP).....	5-71
5.19.	REMOTE BUGS PANEL.....	5-72
5.20.	REMOTE BUGS PANEL (AW-109SP).....	5-75
5.20.1.	<i>Heading Encoder</i>	5-75
5.20.2.	<i>Altitude Encoder (AW-109SP)</i>	5-76
5.20.3.	<i>Multifunction Encoder.....</i>	5-76
5.20.4.	<i>LNAV Button (AW-109SP)</i>	5-77
5.20.5.	<i>VNAV Button (AW-109SP).....</i>	5-77
5.21.	PFD DECLUTTER (DCLTR) MENU.....	5-78

5.21.1.	<i>PFD Declutter (DCLTR) Menu (Step-By-Step)</i>	5-80
5.22.	PFD DECLUTTER (DCLTR) MENU	5-81
5.23.	PFD ALTIMETER MENU	5-82
5.23.1.	<i>PFD Altimeter Menu (Step-By-Step)</i>	5-83
5.24.	MFD FAULT DISPLAY (FAULTS) MENU	5-84
5.24.1.	<i>MFD Fault Display (FAULTS) Menu (Step-By-Step)</i>	5-87
5.25.	MFD FUEL TOTALIZER QUANTITY SETTING (SET FUEL) MENU	5-87
5.25.1.	<i>MFD Fuel Totalizer Quantity Setting (SET FUEL) Menu (AW-109SP)</i>	5-88
5.26.	MFD PAGE	5-88
5.26.1.	<i>MFD Page (PAGE) Menu (Step-By-Step)</i>	5-89
5.26.2.	<i>MFD NAV Log Page</i>	5-90
5.26.3.	<i>MFD ND Page Format (FORMAT) Menu</i>	5-91
5.26.4.	<i>MFD ND Page Format (FORMAT) Menu (Step-By-Step)</i>	5-94
5.26.5.	<i>MFD HSI Page</i>	5-95
5.26.6.	<i>MFD HSI Pointer (PTRS) Menu</i>	5-96
5.26.7.	<i>MFD Strike Format (FORMAT) Menu</i>	5-97
5.26.8.	<i>MFD Traffic Format (FORMAT) Menu</i>	5-98
5.26.9.	<i>MFD Datalink Format (FORMAT) Menu</i>	5-99
5.26.10.	<i>MFD Video Input Format (FORMAT) Menu</i>	5-100

List of Figures and Tables

FIGURE 5-1: IDU-450 INPUT CONTROLS.....	5-8
TABLE 5-1: MENU SYNCHRONIZATION.....	5-8
FIGURE 5-2: PFD TOP-LEVEL MENU	5-13
TABLE 5-2: TOP-LEVEL MENU AUTOMATIC FUNCTION DESCRIPTIONS PRECEDENCE, TILE LEGEND, AND ACTION	5-15
FIGURE 5-3: FIRST PAGE PFD	5-19
FIGURE 5-4: FIRST-LEVEL MFD	5-21
TABLE 5-3: LOWER-LEVEL MENUS BUTTON/ROTARY ENCODER.....	5-22
FIGURE 5-5: IDU-450 INPUT CONTROLS.....	5-22
FIGURE 5-6: FLIGHT PLAN MENU.....	5-23
FIGURE 5-7: CREATION OF OVERFLY USER WAYPOINT.....	5-25
FIGURE 5-8: FLIGHT PLAN MENU SELECTION	5-25
FIGURE 5-9: FLIGHT PLAN MENU CREATE-EDIT (MFD ONLY).....	5-26
FIGURE 5-10: ACTIVATE FLIGHT PLAN (MFD ONLY).....	5-27
FIGURE 5-11: EDIT FLIGHT PLAN (MFD ONLY)	5-28
FIGURE 5-12: EDIT FLIGHT PLAN (MFD ONLY)	5-29
FIGURE 5-13: DELETE FLIGHT PLAN (MFD ONLY).....	5-30
FIGURE 5-14: CREATE USER WAYPOINT (LAT-LON) (MFD ONLY).	5-31
FIGURE 5-15: CREATE USER WAYPOINT (RAD-DST) (MFD ONLY)	5-32
FIGURE 5-16: EDIT USER WAYPOINT (MFD ONLY)	5-33
FIGURE 5-17: DELETE USER WAYPOINT (MFD ONLY).....	5-34
FIGURE 5-18: RAIM PREDICTION (MFD ONLY).....	5-35
FIGURE 5-19: ACTIVE FLIGHT PLAN MAIN MENU	5-37
FIGURE 5-20: ACTIVE FLIGHT PLAN MENU OPTIONS	5-42
FIGURE 5-21: ACTIVE FLIGHT PLAN MENU OPTIONS (STEP-BY-STEP)	5-47
FIGURE 5-22: ACTIVE FLIGHT PLAN MENU (STEP-BY-STEP).....	5-48
FIGURE 5-23: ACTIVE FLIGHT PLAN OPTIONS NRST MENU OPTION (STEP-BY-STEP)	5-49
FIGURE 5-24: INFORMATION MENU.....	5-50
FIGURE 5-25: CRS SYNC.....	5-52
FIGURE 5-26: INFORMATION (STEP-BY-STEP).....	5-52
FIGURE 5-27: OMNIBEARING SELECTOR (OBS) MENU	5-53
FIGURE 5-28: OMNIBEARING SELECTOR (OBS) (STEP-BY-STEP) ...	5-54
FIGURE 5-29: HEADING BUG (HDG) MENU.....	5-55
FIGURE 5-30: HEADING BUG (HDG) MENU (STEP-BY-STEP).....	5-55
FIGURE 5-31: NEAREST (NRST) MENU	5-56
FIGURE 5-32: NEAREST (NRST) MENU (STEP-BY-STEP).....	5-58
FIGURE 5-33: NEAREST (NRST) MENU ILS.....	5-59
FIGURE 5-34: DIRECT MENU	5-60
FIGURE 5-35: DIRECT MENU (STEP-BY-STEP).....	5-62
FIGURE 5-36: TIMER MENU.....	5-63

FIGURE 5-37: TIMER MENU (STEP-BY-STEP).....	5-64
FIGURE 5-38: PFD SOURCE MENU.....	5-65
FIGURE 5-39: PFD PAGE FIRST-LEVEL SOURCE SELECTION (STEP-BY-STEP).....	5-66
FIGURE 5-40: PFD BUGS (BUGS) MENU (N/A FOR AW-109SP) ...	5-67
FIGURE 5-41: PFD BUGS (BUGS) MENU (N/A FOR AW-109SP) (CONTINUED).....	5-68
FIGURE 5-42: PFD BUGS MENU (STEP-BY-STEP) (N/A FOR AW-109SP).....	5-70
FIGURE 5-43: PFD BUGS (STEP-BY-STEP) (N/A FOR AW-109SP).....	5-71
FIGURE 5-44: REMOTE BUGS PANEL	5-72
TABLE 5-4: REMOTE BUGS PANEL (RBP)	5-73
FIGURE 5-45: PFD DECLUTTER (DCLTR) MENU	5-78
FIGURE 5-46: PFD DECLUTTER (DCLTR) MENU (STEP-BY-STEP).....	5-80
FIGURE 5-47: PFD DECLUTTER (DCLTR) MENU (STEP-BY-STEP) (CONTINUED).....	5-81
FIGURE 5-48: PFD ALTIMETER MENU	5-82
FIGURE 5-49: ALTIMETER MENU (STEP-BY-STEP).....	5-83
FIGURE 5-50: MFD FAULT DISPLAY MENU.....	5-84
FIGURE 5-51: MFD FAULT DISPLAY MENU (STEP-BY-STEP).....	5-87
FIGURE 5-52: MFD FUEL TOTALIZER QUANTITY MENU	5-87
FIGURE 5-53: MFD PAGE (PAGE) MENU	5-88
FIGURE 5-54: MFD PAGE MENU (STEP-BY-STEP)	5-89
FIGURE 5-55: NAV LOG PAGE MENU (STEP-BY-STEP)	5-90
FIGURE 5-56: MFD ND PAGE FORMAT MENU	5-91
FIGURE 5-57: MFD SYMBOL DECLUTTER.....	5-92
FIGURE 5-58: MFD ND PAGE FORMAT (STEP-BY-STEP).....	5-94
FIGURE 5-59: HSI PAGE MENU (STEP-BY-STEP)	5-95
FIGURE 5-60: MFD HSI POINTER (PTRS) MENU	5-96
FIGURE 5-61: MFD STRIKE FORMAT MENU.....	5-97
FIGURE 5-62: MFD TRAFFIC FORMAT MENU.....	5-98
FIGURE 5-63: MFD DATALINK FORMAT MENU.....	5-99
FIGURE 5-64: MFD VIDEO INPUT FORMAT MENU	5-100
TABLE 5-5: VIDEO INPUT CONTROLS.....	5-101

5.1. Menu Functions

Navigate IDU menu functions by using the eight peripheral buttons and lower right (1) rotary encoder. The rotary encoder in the lower left corner of the IDU-450 is only used for adjusting screen and button brightness and cannot be used for menu functions.



Figure 5-1: IDU-450 Input Controls

5.2. Menu Synchronization

System settings changed by the menu system are synchronized between multiple IDUs in MFD-MFD mode according to the following tables.

Table 5-1: Menu Synchronization

Menu Parameter	Notes
<p><i>The following menu parameters are synchronized across all displays at all times. These are bugs and fundamental aircraft values that should never have independence.</i></p>	
Fuel Totalizer Quantity	

Table 5-1: Menu Synchronization

Menu Parameter	Notes
VNAV Climb Angle	
Countdown Timer Start Time	
Countdown Timer Default Value	
Remote Tune Frequencies	
VNAV Descent Angle	
Decision Height Setting	“Used when Dual Decision Height Flag is false.” (In the configuration settings).
Emergency and Minimum Fuel Settings	N/A for AW-109SP
Heading Bug	
Minimum Altitude Bug Value	
VLOC OBS Settings	
Airspeed Bug Setting	N/A for AW-109SP
Target Altitude Bug Setting	
Timer Starting Signal	
Traffic Filter Setting	
VSI Bug Setting	
Crosslink Synchronization Status	

Table 5-1: Menu Synchronization

Menu Parameter	Notes
<p><i>The following menu parameters are synchronized across all displays when crosslink is enabled. Otherwise, they are only synchronized onside. These parameters are FMS parameters and allow the pilot and co-pilot FMS's to be operated independently when crosslink is inhibited.</i></p>	
Active Flight Plan Parameters	
Runway Display Parameters	
<p><i>The following menu parameters are only synchronized onside. These parameters are usually sensor selections or PFD options used to keep the appearance of any pilot's PFD consistent in the case of PFD reversion. The onside characteristic means that individual pilots can still adjust their PFD settings to their preference.</i></p>	
Sensor Selections	
Transition Altitude	
Barometric Setting Units	
Barometric Setting Value	
Barometric Setting Mode	
Decision Height Setting	Used when "Dual Decision Height Flag" is true. (In the configuration settings).
Navigation Source	
PFD Basic Mode	
PFD Zoom Mode	
PFD Analog AGL	

Table 5-1: Menu Synchronization

Menu Parameter	Notes
PFD Full-time Bank Scale Flag	
PFD Flight Director Show Flag	
PFD Generic OASIS Overlay Show Flag	
PFD Mini-map Show Flag	
PFD Altitude (meters) Show Flag	
PFD Traffic Thumbnail Show Flag	
PFD Skyway Show Flag	
PFD Terrain Show Flag	
PFD Traffic Show Flag	
Weather Radar Scale	Onside because range is controlled by the weather radar.
Rate of turn indication flag	
<i>The following menu parameters are independent between displays. These are used to support non-PFD display options to give the pilot maximum MFD operating flexibility.</i>	
MFD Selected Page	Note that this parameter is transmitted to all other IDUs to support weather radar vertical profile mode selection
MFD Datalink Page Settings	

Table 5-1: Menu Synchronization

Menu Parameter	Notes
MFD Map Page Settings	Note that map scale is transmitted outside to support weather radar range selection.
MFD Map and HSI Page Pointer Settings	
MFD Map Function Declutter Settings	
MFD Show ETA Flag	
MFD Map NavData Symbol Declutter Settings	
MFD Strike (WX-500) Page Settings	
MFD Traffic Page Settings	
MFD Video Page Settings	Selected Input Brightness Contrast Saturation Hue (Note: the above are video hardware settings)

5.3. Menu Function Types

There are two types of menu functions on the IDU-450, top-level menu functions corresponding to the labeled pushbutton, and soft menu functions indicated by menu tiles which appear on screen. Soft menu functions take precedence over functions associated with IDU pushbuttons. These soft menu functions may include an indication of further menu levels with a two-dot trailer.

Soft menu function tiles appear next to the appropriate IDU button or in the lower right corner when use of the encoder is appropriate.

Whenever the menu system is beyond the top-level, **EXIT** appears adjacent to the top right pushbutton (**R1**) to provide one touch escape to the top-level. Whenever a soft menu level is deeper than the first-level, **BACK** appears adjacent to the top left pushbutton (**L1**) to regress through the menu system by one level.

5.4. Top-Level Menu

On the IDU-450, the top-level menu corresponds to the permanent label of the IDU pushbuttons and is active anytime no soft menu options appear on the screen.

5.4.1. IDU-450 PFD Normal Mode Top-Level Menu

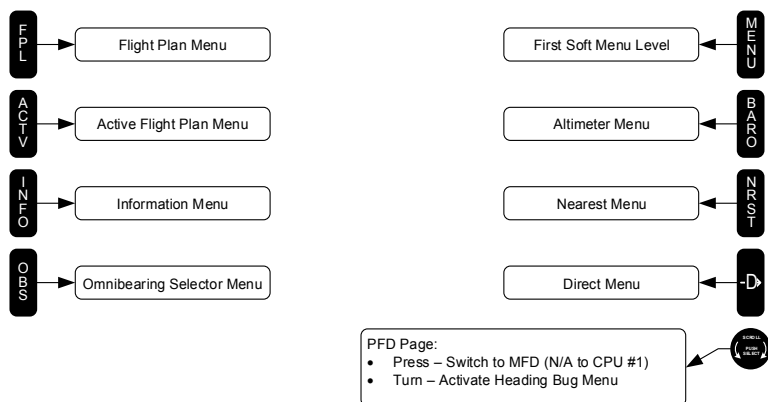



Figure 5-2: PFD Top-Level Menu

IDU-450 encoder function depends upon page as follows:

- 1) On the PFD page, scroll **1** to activate the heading menu option.
- 2) On MFD pages with an adjustable display scale (e.g., ND, Strike, Traffic, Datalink, Hover, or Weather Radar with type Honeywell RDR-2000 or RDR-2100), scroll **1** to change the display scale (clockwise = increase, counterclockwise = decrease).
- 3) On the Video page, scroll **1** to change the zoom level (clockwise = increase, counterclockwise = decrease).

- 4) With the exception of IDU #1, push **1** to swap between the PFD and MFD . IDU #1 is always fixed to the PFD page.

5.5. Top-Level Menu Option Descriptions

- 1) **FPL (L1)**: Flight plan menu
- 2) **ACTV (L2)**: Active flight plan menu
- 3) **INFO (L3)**: Information menu
- 4) **OBS (L4)**: Omnibearing selector menu
- 5) **MENU (R1)**: First-level associated with the current display page and automatically times out after 10 seconds if there are no subsequent pilot actions.
- 6) **BARO (R2)**: Altimeter menu option
- 7) **NRST (R3)**: Nearest menu option
- 8)  **(R4)**: Direct menu option

5.5.1. Top-Level Menu Soft Menu Tiles (AW-109SP)

Once Horizon Synchronization is armed, vertical **HS ON (L2)** appears on the “transmit enabled” IDU. Press **HS ON (L2)** to engage Horizon Synchronization mode and apply the appropriate offset to displayed pitch attitude. Once engaged in Horizon Synchronization mode, **HS OFF (L2)** appears on the “transmit enabled” IDU. Press **HS OFF (L2)** to cancel Horizon Synchronization mode. Horizon Synchronization mode is also cancelled when the availability logic is no longer met. In most cases, Horizon Synchronization is cancelled by accelerating through the Cat. A range (60KIAS) rather than by pressing **HS OFF (L2)**.

5.5.2. #1 Encoder (**1**)

- 1) On a PFD, scroll to activate the heading menu.
- 2) On the MFD pages with an adjustable display scale (e.g., ND, Strike, Traffic, Datalink, Hover, or Weather Radar), scroll to change the display scale (clockwise = increase, counterclockwise = decrease).

- 3) On the IDU-450 Video page, scroll to change the zoom level (clockwise = increase, counterclockwise = decrease).
- 4) With the exception of IDU #1, push to swap between the PFD and MFD . IDU #1 is always fixed to the PFD page.

5.5.3. Top-Level Menu Automatic Pop-up Function Descriptions

Under certain conditions, soft menu tiles appear at the top-level to provide single-touch access to needed functions. The following soft menu tiles appear adjacent to the specified pushbutton under the specified conditions.

Table 5-2: Top-Level Menu Automatic Function Descriptions Precedence, Tile Legend, and Action

<p>(FPL) (L1)</p>	<ol style="list-style-type: none"> 1) When a terrain popup occurs during a TAWS FLTA alert, RESET appears. (ENHANCED HTAWS only) 2) When showing the Datalink Page with Pan Mode enabled, PN OFF appears. Press to disable Pan Mode. RESET has precedence over PN OFF. 3) When showing ND Page with Pan Mode enabled, PN OFF appears. Press to disable Pan Mode. RESET has precedence over PN OFF. 4) When the display is “transmit enabled”, LNAV appears. When there is an active flight plan, heading bug sub-mode is active, and the system is integrated with an analog autopilot. Press to deactivate heading bug sub-mode and resume guidance to the active flight plan path. RESET and PN OFF have precedence over LNAV. LNAV does not appear on the AW-109SP ; the pilot must use the RBP LNAV button. 5) When the display is “transmit enabled”, MISS appears upon transitioning the Final Approach Fix. Press to activate the missed approach
------------------------------	---

**Table 5-2: Top-Level Menu Automatic Function Descriptions
Precedence, Tile Legend, and Action**

	<p>procedure. RESET, PN OFF, and LNAV have precedence over MISS.</p> <p>6) When the display is “transmit enabled”, CONT appears when in a holding pattern with further active flight plan legs after the holding pattern. Press to re-enable automatic waypoint sequencing to allow normal sequencing to the leg after the holding pattern. RESET, PN OFF, LNAV, and MISS have precedence over CONT.</p>
<p>(ACTV) (L2)</p>	<p>1) When showing Datalink Page with Winds and Temperatures Aloft enabled, UP appears. Press to increase the Winds and Temperatures Aloft grid. Does not appear when the highest grid level is being displayed.</p> <p>2) When showing Video Input Page with Pan Mode enabled, UP appears. Press to move up the section of the video image displayed in the full video image.</p> <p>3) When showing Datalink Page with: (a) Pan Mode enabled; (b) information for the nearest highlighted waypoint being shown; and (c) airport weather information present in the information block; WX appears to allow the display of textual METAR and TAF data for the airport. UP has precedence over WX.</p> <p>4) When showing ND Page with: (a) Pan Mode enabled; (b) information for the nearest highlighted waypoint being shown; and (c) airport weather information present in the information block; WX appears to allow the display of textual METAR and TAF data for the airport. UP has precedence over WX.</p> <p>5) When the display is “transmit enabled”, VNAV appears when VNAV guidance is valid, the selected altitude sub-mode is active, and the system is integrated with an analog autopilot or</p>


**Table 5-2: Top-Level Menu Automatic Function Descriptions
Precedence, Tile Legend, and Action**

	<p>HeliSAS-E. Press to deactivate the selected altitude sub-mode and resume guidance to the VNAV path. UP and WX have precedence over VNAV. The VNAV does not appear on the AW-109SP ; the pilot must use the RBP VNAV button.</p> <p>6) When the display is “transmit enabled”, ARM appears when on the Final Approach Segment (between the Final Approach Fix and Missed Approach Point). Press to arm the Missed Approach Procedure to automatically activate upon sequencing the Missed Approach Point. UP, WX, and VNAV have precedence over ARM. (See #5 for AW-109SP)</p>
<p>INFO (L3)</p>	<p>1) When showing Datalink Page with Pan Mode enabled, NORTH appears. Press to shift the center of the Pan Mode Datalink Page in the specified direction.</p> <p>2) When showing ND Page with Pan Mode enabled, NORTH appears. Press to shift the center of the Pan Mode ND Page in the specified direction.</p> <p>3) When showing Video Input Page with pan mode enabled, DOWN appears. Press to move down the section of the video image displayed in the full video image.</p>
<p>(OBS) (L4)</p>	<p>1) When showing Datalink Page with Pan Mode enabled, SOUTH appears. Press to shift the center of the Pan Mode Datalink Page in the specified direction.</p> <p>2) When showing ND Page with Pan Mode enabled, SOUTH appears. Press to shift the center of the Pan Mode ND Page in the specified direction.</p>

**Table 5-2: Top-Level Menu Automatic Function Descriptions
Precedence, Tile Legend, and Action**

(BARO) (R2)	<ol style="list-style-type: none"> 1) When showing Datalink Page with Winds and Temperatures Aloft enabled, DOWN appears. Press to decrease the Winds and Temperatures Aloft grid level. Not shown when the lowest grid level is displayed. 2) When showing Video Input Page with pan mode enabled, LEFT appears. Press to move left the section of the video image displayed in the full video image. 3) When showing Datalink Page with Pan Mode enabled, INFO or HIDE appears. Press to toggle the display of information for the nearest highlighted waypoint. Refer to the INFO menu requirements for the amount and type of information presented. DOWN has precedence over INFO/HIDE. 4) When showing ND Page with Pan Mode enabled, INFO or HIDE appears. Press to toggle the display of information for the nearest highlighted waypoint.
(NRST) (R3)	<ol style="list-style-type: none"> 1) When showing Datalink Page with Pan Mode enabled, EAST appears. Press to shift the center of the Pan Mode Datalink Page to shift in the specified direction. 2) When showing ND Page with Pan Mode enabled, EAST appears. Press to shift the center of the Pan Mode ND Page in the specified direction. 3) When showing Video Input Page with pan mode enabled, RIGHT appears. Press to move right the section of the video image displayed in the full video image.
(Direct-To)	<ol style="list-style-type: none"> 1) When showing Datalink Page with Pan Mode enabled, WEST appears. Press to shift the

Table 5-2: Top-Level Menu Automatic Function Descriptions Precedence, Tile Legend, and Action

 (R4)	<p>center of the Pan Mode Datalink Page in the specified direction.</p> <p>2) When showing ND Page with Pan Mode enabled, WEST appears. Press to shift the center of the Pan Mode ND Page in the specified direction.</p>
--	--

5.6. First Page (PFD)

On the IDU-450, IDU #1 is fixed to the PFD page, and other IDUs may show the PFD page as a backup function. IDU-450 PFD page first-level options are as follows.

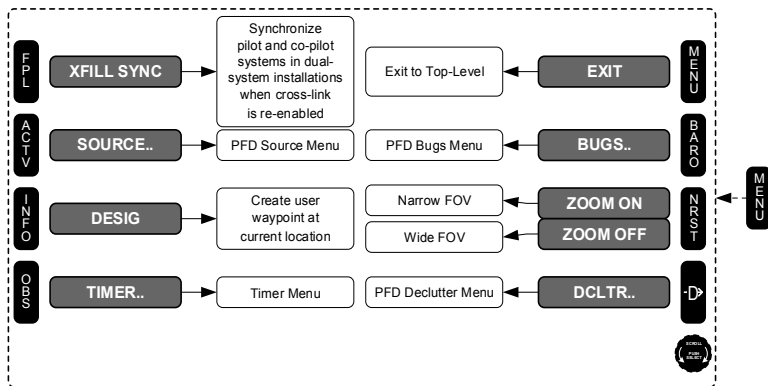



Figure 5-3: First Page PFD

5.6.1. PFD Page First-Level Option Descriptions

- 1) **XFILL SYNC (FPL) (L1)**: Appears in dual-system installations where the pilot and co-pilot systems are not synchronized, but crosslink is enabled. Press to synchronize the pilot and co-pilot active flight plan parameters to the system where the button press occurred.

- 2) **Source (ACTV) (L2)**: Activates PFD source selection menu option.
- 3) **DESIG (INFO) (L3)**: Creates a user waypoint at the current aircraft location. In addition, if pressed with an ND page operating in panning mode, creates a user waypoint at the phantom panning location. User waypoint is automatically named "OF####", where '####' is the next available over-fly user waypoint number.
- 4) **TIMER (OBS) (L4)**: Activates timer menu option.
- 5) **BUGS (BARO) (R2)**: Activates PFD bug set menu option.
- 6) **ZOOM ON/ZOOM OFF (NRST) (R3)**: Toggles between wide FOV mode and narrow FOV mode. **ZOOM ON** appears when current mode is wide FOV. **ZOOM OFF** appears when current mode is narrow FOV.
- 7) **DCLTR**  **(R4)**: Activates PFD declutter menu option.

5.6.2. PFD Screen First Soft Menu Level

When Horizon Synchronization is available and the IDU is "transmit enabled", **HRZ SYNC (L2)** appears in the PFD screen first soft menu level. **HRZ SYNC** takes precedence over the PFD Source menu. Press **HRZ SYNC (L2)** to arm Horizon Synchronization mode. It is anticipated the pilot takes this action on a Cat. A departure prior to lifting the helicopter into hover flight (AW-109SP only).

XFILL SYNC (L1) in the PFD Screen First Soft Menu Level appears when all of the following conditions are met:

- 1) Crosslink status is enabled; And
- 2) Crosslink synchronization status is not enabled; And
- 3) Discrete input for Crossfill Inhibit is not enabled; And
- 4) Side in command is valid; AND
- 5) AFCS Status is set to invalid.

5.6.3. First-Level (MFD)

IDUs other than #1 may show various MFD pages as described in the MFD Page Menu section. MFD page first-level options are as follows.

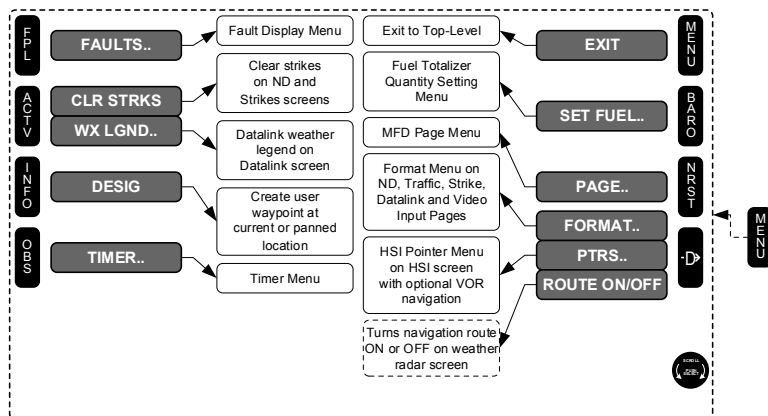


Figure 5-4: First-Level MFD

- 1) **FAULTS (FPL) (L1)**: Activates fault display menu option.
- 2) **CLR STRKS** or **WX LGND (ACTV) (L2)**: On ND page or Strike page with WX-500 option enabled, **CLR STRKS** activates strike clear option for the Goodrich/L-3 WX-500. On Datalink page, **WX LGND** activates datalink weather legend.
- 3) **DESIG (INFO) (L3)**: Same function as PFD page first-level.
- 4) **TIMER (OBS) (L4)**: Same function as PFD page first-level.
- 5) **SET FUEL (BARO) (R2)**: Activates fuel totalizer set menu option.
- 6) **PAGE (NRST) (R3)**: Activates MFD display page select menu option.
- 7) **FORMAT, PTRS, or ROUTE ON/ROUTE OFF (R4)**:
 - a) **FORMAT**: On the ND, Traffic, Strike, Datalink, and Video Input pages, activates the appropriate page format menu option.

- b) **PTRS**: On HSI page with optional VOR or ADF symbology enabled, activates HSI RMI pointer menu option.
- c) **ROUTE ON/ROUTE OFF**: On Weather Radar page, toggles the display of the active flight plan on the horizontal weather radar display. **ROUTE ON** appears when the display of the active flight plan is disabled. **ROUTE OFF** appears when the display of the active flight plan is enabled.

5.7. Lower-Level Menu (Below First-Level)

The top-level and first-level menus, called lower-level menu, are described in this section, and the eight pushbuttons and rotary encoder control them. In the following diagrams, button and encoder numbers are defined according to the following table and interpreted according to the following view.

Button L1	FPL	Button R1	MENU
Button L2	ACTV	Button R2	BARO
Button L3	INFO	Button R3	NRST
Button L4	OBS	Button R4	
Lower-Right Rotary Encoder			



Figure 5-5: IDU-450 Input Controls

5.8. Flight Plan (FPL) Menu

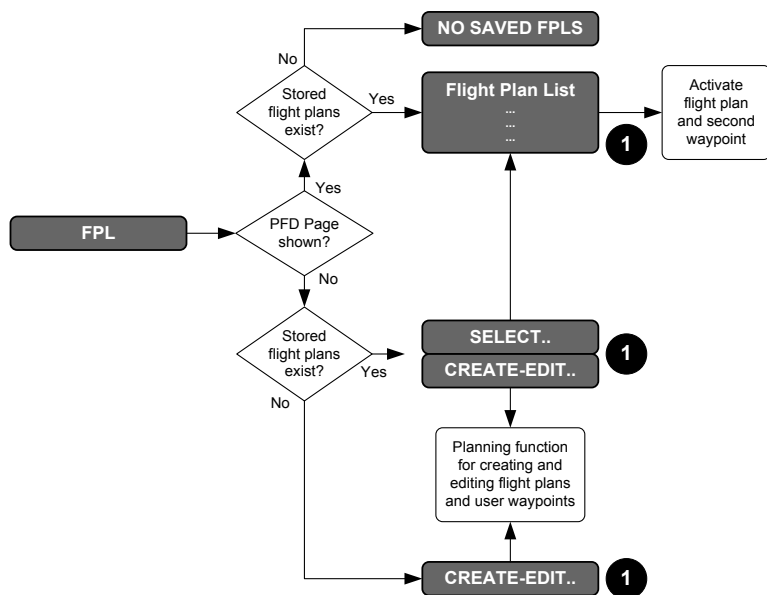


Figure 5-6: Flight Plan Menu

5.8.1. Flight Planner Page

The Flight Planner page is used for detailed operations on pilot-modifiable elements in the IDU database. Through the Flight Planner page, the following types of functions are performed:

- 1) Manage stored flight plans (activate, create, edit, delete, and reverse);
- 2) Manage user waypoints (create, edit, and delete); and
- 3) Perform RAIM predictions.

These operations demand pilot attention and are not normal operating conditions for the IDU. When the Flight Planner page is in use, the Flight Planner page takes over the IDU's controls and disables the menu operations described in this document. Normal menu operation and IDU control function are restored upon:

- 1) Exit the Flight Planner page; or

- 2) Because the Flight Planner page takes over the IDU's controls, limitations are placed upon access and display of the Flight Planner page. When the Flight Planner page is accessed, it only appears on the MFD . This is done to preserve access to crucial PFD Page controls such as altimeter settings.

Upon activation of the flight plan menu, the application checks for the existence of saved flight plans. If there are no saved flight plans, a **NO SAVED FPLS** advisory is issued. Otherwise, a selection list of saved flight plans is presented. Upon selection of a saved flight plan, the second waypoint in the flight plan is activated.

5.8.2. MFD Page Shown on IDU

Upon activation of the flight plan menu, the application checks for the existence of saved flight plans. If there are no saved flight plans, the Flight Planner page is activated. Otherwise, an option list is presented for the pilot to either select a saved flight plan or enter the flight planning page. Selecting the saved flight plan option leads to a list of saved flight plans. Upon selection of a saved flight plan, the second waypoint in the flight plan is activated.

5.8.3. To Create an Overfly User Waypoint

When flying over intended waypoint, press **MENU** then **DESIG** on the PFD or MFD . A user waypoint is created at the present position and automatically named "OF####", where '####' is the next in sequence overfly user waypoint number available. When in the Pan Mode and the aircraft position is slewed, a second user waypoint is created at the original position. Change the waypoint name may be using the "EDIT USER WPT " function on the MFD .

NOTE:

A maximum of 998 user waypoints may be created and stored.



Figure 5-7: Creation of Overfly User Waypoint

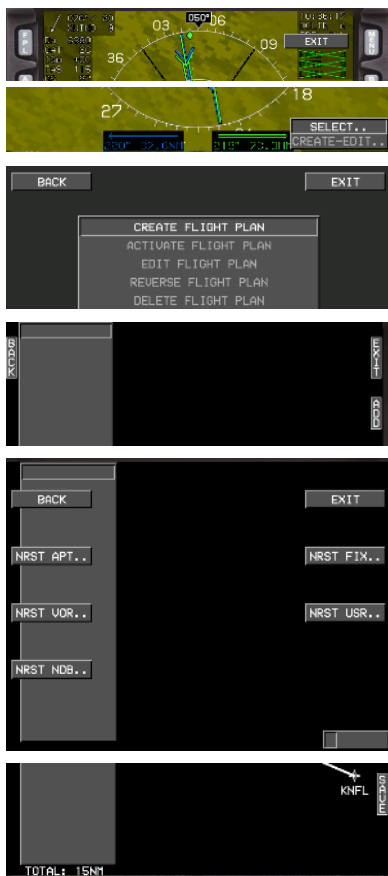
5.8.4. Flight Plan (FPL) Menu Selecting (Step-By-Step)



- 1) Press **FPL (L1)**.
- 2) Scroll **1** to desired flight plan and push to enter.

Figure 5-8: Flight Plan Menu Selection

5.8.5. Flight Plan (FPL) Menu Create-Edit (MFD Only) (Step-By-Step)



- 1) Press **FPL (L1)**.
- 2) Scroll **1** to **CREATE-EDIT..** and push to enter.
- 3) Push **1** to enter.
- 4) Press **ADD (R2)** to begin creating first waypoint.
- 5) Either create a new waypoint with the encoder or press **NRST APT..**, **NRST VOR..**, **NRST NDB..**, **NRST FIX..**, or **NRST USR..**, and make desired selection. Push **1** to enter.
- 6) When finished, press **SAVE (R4)** and the new flight plan is created and stored as one of the 100 flight plans in memory. When 100 flight plans are present, the **CREATE FLIGHT PLAN** option is absent.
- 7) If no other action is necessary press **BACK (L1)** to return to function select page or **EXIT (R1)** to exit the **CREATE FLIGHT PLAN** menu.

Figure 5-9: Flight Plan Menu Create-Edit (MFD Only)

5.8.6. Activate Flight Plan (MFD Only) (Step-By-Step)

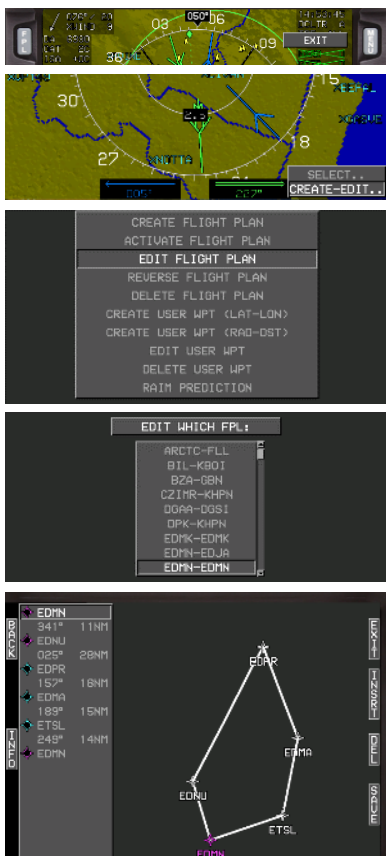


- 1) Press **FPL (L1)**.
- 2) Scroll **1** to **SELECT..** and push to enter.
- 3) Scroll **1** to desired saved flight plan and push to enter. This exits the menu and returns the display to normal operation.

Or
- 4) From inside the **CREATE-EDIT** flight planer, push **1** to enter.
- 5) Scroll **1** to **ACTIVATE FLIGHT PLAN** and push to enter.
- 6) Scroll **1** to desired saved flight plan and push to enter.
- 7) If no other action is necessary press **BACK (L1)** to return to function select page or **EXIT (R1)** to exit the **ACTIVATE FLIGHT PLAN** menu.

Figure 5-10: Activate Flight Plan (MFD Only)

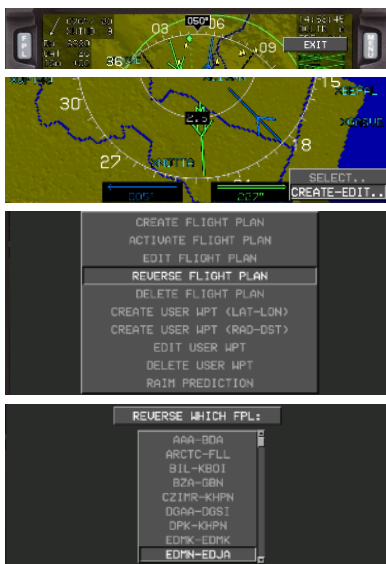
5.8.7. Edit Flight Plan (MFD Only) (Step-By-Step)



- 1) Press **FPL (L1)**.
- 2) Scroll **1** to **CREATE-EDIT..** and push to enter.
- 3) Scroll **1** to **EDIT FLIGHT PLAN** and push to enter.
- 4) Scroll **1** to desired flight plan and push to enter.
- 5) Edit flight plan by adding or deleting waypoints as appropriate.
- 6) Press **SAVE (R4)** to save.
- 7) If no other action is necessary press **BACK (L1)** to return to function select page or **EXIT (R1)** to exit the **EDIT FLIGHT PLAN** menu.

Figure 5-11: Edit Flight Plan (MFD Only)

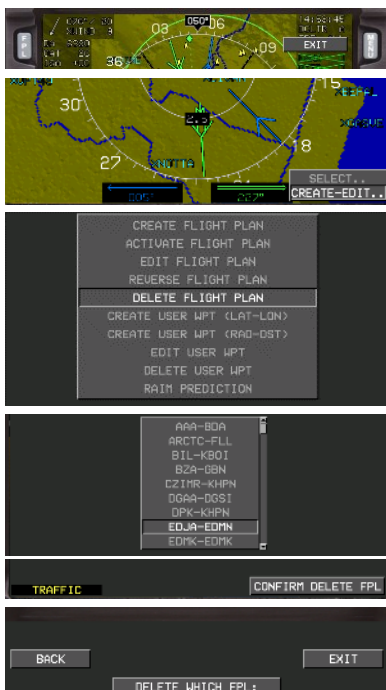
5.8.8. Reverse Flight Plan (MFD Only) (Step-By-Step)



- 1) Press **FPL (L1)**.
- 2) Scroll **1** to **CREATE-EDIT..** and push to enter.
- 3) Scroll **1** to **REVERSE FLIGHT PLAN** and push to enter.
- 4) Scroll **1** to desired flight plan and push to enter.
- 5) If no other action is necessary press **BACK (L1)** to return to function select page or **EXIT (R1)** to exit the **REVERSE FLIGHT PLAN** menu.

Figure 5-12: Edit Flight Plan (MFD Only)

5.8.9. Delete Flight Plan (MFD Only) (Step-By-Step)



- 1) Press **FPL (L1)**.
- 2) Scroll **1** to **CREATE-EDIT..** and push to enter.
- 3) Scroll **1** to desired flight plan to be deleted and push to enter.
- 4) Push **1** to **CONFIRM DELETE FPL.**
- 5) The next flight plan is highlighted. If no further deletions are required, proceed to next step.
- 6) If no other action is necessary press **BACK (L1)** to return to function select page or **EXIT (R1)** to exit the **DELETE FLIGHT PLAN** menu.

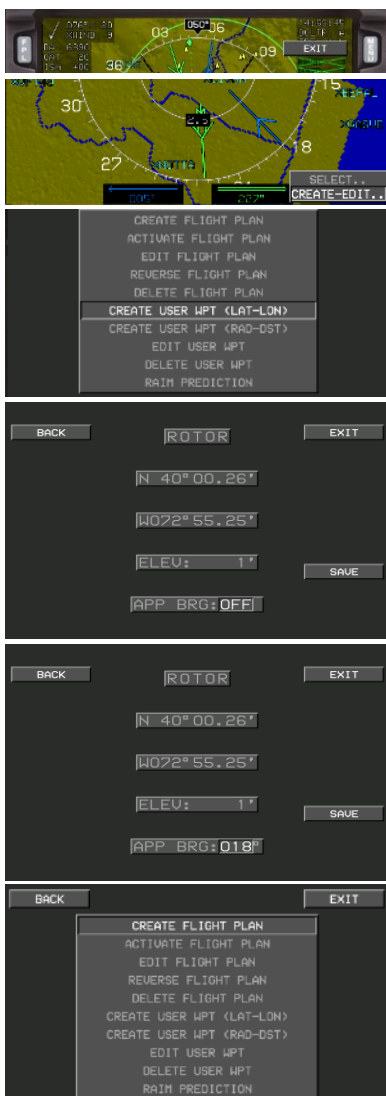
Figure 5-13: Delete Flight Plan (MFD Only)

5.8.10. Create User Waypoint (LAT-LON) (MFD Only) (Step-By-Step)

User waypoints may be created with three methods:

- 1) Latitude and Longitude
- 2) Radial and Distance
- 3) Overfly (Designate)

Follow the step-by-step procedure defined below to create a user waypoint using latitude and longitude.



- 1) Press **FLP (L1)**.
- 2) Scroll **1** to **CREATE-EDIT..** and push to enter.
- 3) Scroll **1** to **CREATE USER WPT (LAT-LON)** and push to enter.
- 4) A new user waypoint may be named. Scroll **1** and push to enter all five character spaces. With new name created for user waypoint, continue to press **1** to proceed through all fields as necessary.

Preloading of the approach bearing is dependent upon mode of flight as follows:

On Ground: Preloaded with current heading

In Flight: Preloaded with **OFF** value

If desired, specify the approach bearing to the user waypoint in degrees 1°-360°. **OFF** value disables VFR approaches to the user waypoint. Once all fields are entered, press **SAVE (R4)** to save the user waypoint and return to the editing screen.

Figure 5-14: Create User Waypoint (LAT-LON) (MFD Only)

5.8.11. Create User Waypoint (RAD-DST) (MFD Only) (Step-By-Step)



- 1) Press **FPL (L1)**.
- 2) Scroll **1** to **CREATE-EDIT..** and push to enter.
- 3) Scroll **1** to **CREATE USER WPT (RAD-DST)** and push to enter.

The identifier is automatically named **RD###** where **###** is the next available radial distance waypoint number.*

* **Reference Waypoint:** The pilot is prompted to enter an identifier for the reference waypoint on the second line. Use **1** to enter the reference waypoint in the same manner as a waypoint is entered for a flight plan. If there is a single result from the search, the pilot is advanced to the radial entry box. If there is no result from the search, the pilot is re-prompted to enter an identifier. If there are multiple results from the search, a selection list with matching identifiers is displayed, and upon selection, the pilot is advanced to the radial entry box. **INFO** menu appears at this level and provides access to information for the highlighted result.

Radial Entry: The third line is for pilot to specify a radial from the reference waypoint in increments of degrees.

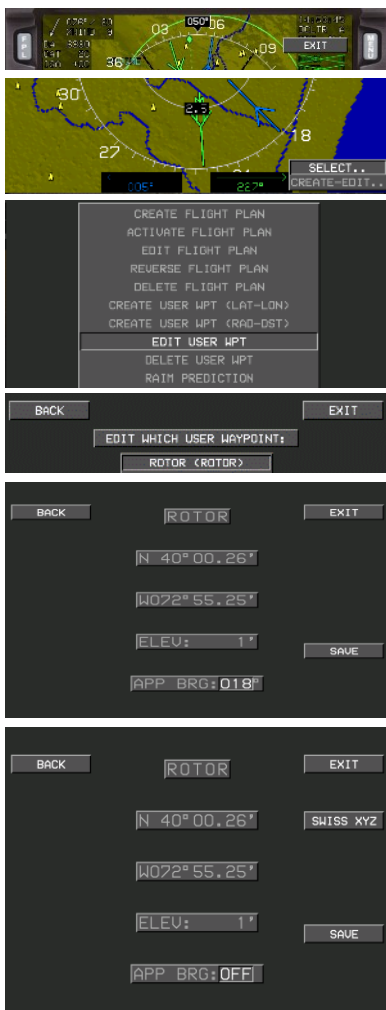
Distance Entry: The fourth line allows the pilot to specify a distance from the reference in increments of tenths of nautical miles.



- 4) After all fields have been entered, press **SAVE (R4)** to save and return to the editing screen.

Figure 5-15: Create User Waypoint (RAD-DST) (MFD Only)

5.8.12. Edit User Waypoint (MFD Only) (Step-By-Step)



- 1) Press **FPL (L1)**.
- 2) Scroll **1** to **CREATE-EDIT..** and push to enter.
- 3) Scroll **1** to **EDIT USER WPT** and push to enter.
- 4) Scroll **1** to desired waypoint to be edited.
- 5) Use **1** to enter alphanumeric characters and follow on-screen prompts to edit information. Push **1** to step through all character spaces.
- 6) To back up press **BACK (L1)** and continue to the end of all character spaces.
- 7) If necessary, select another **USR WPT** to edit or push **SAVE (R4)** to save changes to return to the **EDIT USER WPT** menu.

Figure 5-16: Edit User Waypoint (MFD Only)

5.8.13. Delete User Waypoint (MFD Only) (Step-By-Step)



- 1) Press **FPL (L1)**.
- 2) Scroll **1** to **CREATE-EDIT..** and push to enter.
- 3) Scroll **1** to **DELETE USER WPT** and push to enter.
- 4) Scroll **1** to desired waypoint to be deleted.
- 5) Push **1** to **CONFIRM DEL USER WPT**.
- 6) Press **EXIT (R1)** to exit **DELETE USER WPT** menu and return to the MAP.
- 7) Press **EXIT (R1)** to exit if no more user waypoints are to be deleted.

Figure 5-17: Delete User Waypoint (MFD Only)

NOTE:

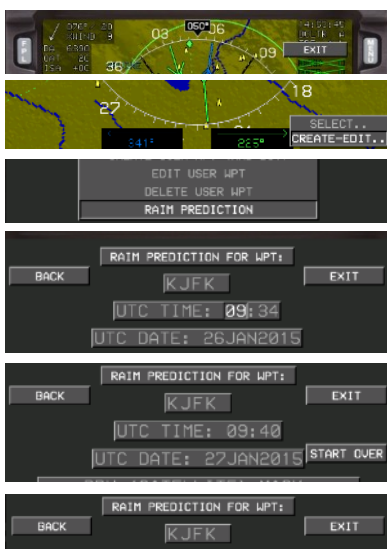
Pilot alterations of user waypoint parameters while in flight do not automatically update to an active flight plan.

When changes are made to a user waypoint, and those changes are desired in existing flight plans which use the waypoint, it must be deleted and replaced in the flight plans with the following steps:

- 1) EDIT the user waypoint as described above
- 2) Open a flight plan which uses the user waypoint
- 3) Delete the existing waypoint from the flight plan
- 4) Save and Exit
- 5) Reload the flight plan if it were in use.

5.8.14. RAIM Prediction

When selected, the RAIM prediction screen is only shown if the GPS/SBAS receiver is capable of performing a RAIM Prediction. There must be no faults along with a current almanac in memory. The **FAULTS** menu may be monitored to determine if the GPS/SBAS receiver is capable of performing a RAIM prediction.



- 1) Press **FPL (L1)**.
- 2) Scroll **1** to **CREATE-EDIT..** and push to enter.
- 3) Scroll **1** to **RAIM PREDICTION** and push to enter.

See note below.

- 4) If another RAIM Prediction is necessary, press **START OVER (R2)** to start the process again or press **EXIT (R1)** to exit the RAIM Prediction menu.

Figure 5-18: RAIM Prediction (MFD Only)

NOTE:

The RAIM prediction screen allows the pilot to perform RAIM prediction at a designated waypoint. The screen has various data entry boxes as follows:

- 1) **Designated Waypoint:** The pilot is prompted to enter an identifier for the designated waypoint. If there is a single result from the search, the pilot is advanced to the UTC time entry box. If there is no result from the search, the pilot is re-prompted to enter an identifier. If there are multiple results from the search, a selection list with matching identifiers is presented and, upon selection, the pilot is advanced to the UTC time entry box. **INFO (L3)** appears at

this level to aid in selection and give access to information for the highlighted results.

- 2) **UTC Time Entry:** Allows entry of the 24-Hour UTC estimated time of arrival at the designated waypoint.
- 3) **UTC Date Entry:** Allows entry of the UTC estimated date of arrival at the designated waypoint.
- 4) **PRN Mask Entry:** Allows the pilot to specify the PRN number of satellites expected to be unavailable at the destination.
- 5) **EXIT:** Allows exit of the RAIM prediction screen at any time.
- 6) Once a designated waypoint and UTC estimated time of arrival are entered, **CALC (R2)** appears for the pilot to initiate the RAIM Prediction . Press **CALC (R2)** to check the UTC estimated time of arrival and ensure it is within the current almanac (i.e., <3.5 days from current date and time). If it is, a Predictive FDE Request message requesting "Detection Availability" with a required HAL of 0.3NM is sent to the GPS/SBAS receiver. In response, the GPS/SBAS receiver replies with a sequence of Predictive FDE Response messages. These messages are parsed and used to fill in the RAIM Prediction result area at the bottom of the screen. The RAIM Prediction result area shows the RAIM Prediction results as "OK" or "XX" for ETA \pm in 5-minute increments. Once a prediction is complete, **START OVER (R2)** appears to allow the pilot to perform another prediction without having to exit the RAIM Prediction screen.

5.9. Active Flight Plan (ACTV) Menu

5.9.1. Main Menu

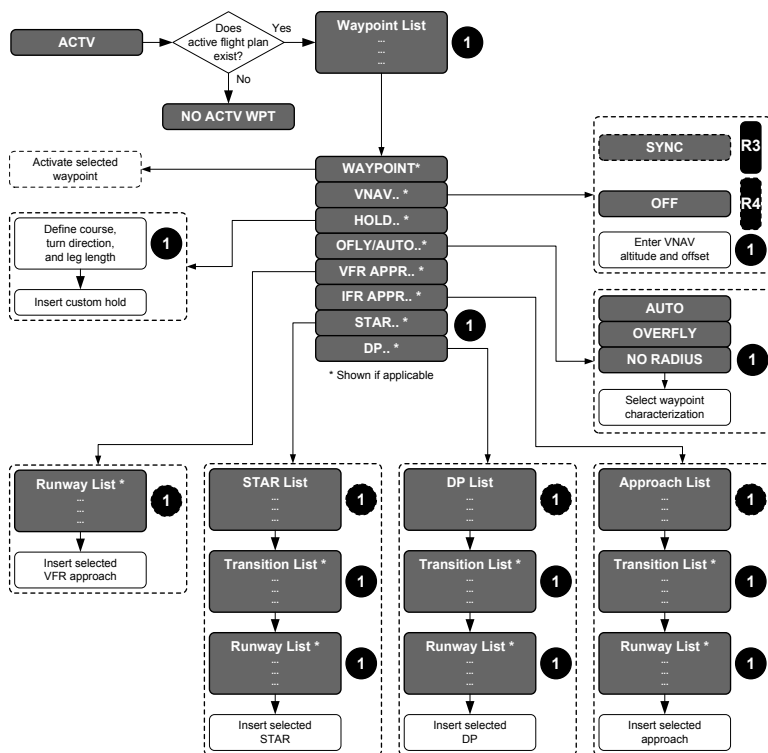


Figure 5-19: Active Flight Plan Main Menu

Upon activation of the active flight plan menu, the application checks for the existence of an active waypoint. If there is no active waypoint, **NO ACTIVE WPT** is issued. Otherwise, a selection list in the form of a nav log of waypoints in the active flight plan is presented. The nav log shows the following:

- 1) Each waypoint identifier and characterization (default, overfly [**OF**] or no radius [**OR**]);
- 2) A symbol designating waypoint type and type of procedure (if any) the waypoint is associated with, and whether the waypoint is subject to a parallel offset (PTK);

- 3) VNAV altitudes and offsets associated with each waypoint;
- 4) Information related to the flight plan path between each waypoint.

In the case of an approach with a Final Approach Segment data block, the VNAV Offset readout associated with the Missed Approach Point is “GPI” to designate distance to the Glidepath Intercept point. When courses are presented as part of the path information, they are displayed referenced to magnetic North with the degree (°) symbol.

VNAV altitudes and offsets from the navigation database or manually entered are shown in white, and offsets altitudes computed automatically are shown in gray. The current active waypoint is designated by an asterisk and is magenta but turns amber (yellow) in the event of a GPS Loss of Navigation caution.

A suppressed waypoint (designated by brackets) is an airport associated with an IFR or VFR approach procedure. After an approach procedure is activated, the associated airport is no longer part of the active flight plan for guidance purposes. However, the associated airport is still shown in the nav log so it may be highlighted for information or to activate other procedures to the airport. Since there may be only one approach active at any given time, there may only be one suppressed waypoint at any given time.

A skipped waypoint is a waypoint associated with a dynamic termination leg with a zero length. These are either:

- 1) An altitude termination leg when current aircraft altitude is above the termination altitude; or
- 2) System-created (i.e., no NavData specified) intercept to a “Course to a Fix” leg where there is insufficient distance to calculate an intercept heading.

Scroll through each waypoint of the flight plan and one position past the end to add a waypoint to the end of the active flight plan. If not, the application makes the selected waypoint active. Otherwise, an option list is presented.

Upon selection of a waypoint from the selection list, the EFIS checks to see whether the selected waypoint meets the criteria for waypoint activation, manual VNAV parameter entry, custom holding pattern entry, manual overfly characterization, VFR approach entry, IFR

approach entry, STAR entry, or DP entry. If it does, an option list is presented as follows:

- 1) **WAYPOINT:** If the selected waypoint is neither suppressed, skipped, nor a manual termination, make the selected waypoint the active waypoint with this option.
- 2) **VNAV:** If the selected waypoint is neither suppressed, skipped, a manual termination, part of an IFR approach, part of a VFR approach, nor a parallel offset entry of exit waypoint the, pilot may enter a manual VNAV altitude and offset for the selected waypoint with this option. This level includes tiles for synchronizing the VNAV altitude to current altitude and for removing the manual VNAV altitude and offset entry. VNAV altitudes are settable in increments of 100 feet, and offsets are settable in increments of 1NM.
- 3) **HOLD:** If the selected waypoint is neither suppressed, skipped, a manual termination, part of an IFR approach after the FAF/FAWP, part of a VFR approach, a holding waypoint, a DP anchor waypoint, nor a parallel offset entry of exit waypoint, the pilot may enter a manual holding pattern at the selected waypoint with this option. The pilot is able to define the course, turn direction (left or right), and leg length (expressed as either distance or time) for the manual holding pattern. Holding pattern course is settable in increments of 1°, and leg length is settable in increments of 1NM or a tenth of a minute.
- 4) **OFFLY/AUTO:** If the selected waypoint is neither suppressed, skipped, a manual termination, a parallel offset, nor an exit waypoint, the pilot may change the waypoint's overfly characterization. The choices are:
 - a) **AUTO:** Reset automatic overfly characterization by the FMS system.
 - b) **OVERFLY:** Manually force the overfly characterization to be an Overfly Adjust-Exit waypoint. This forces the inbound course to go directly to the waypoint regardless of the amount of course change required.
 - c) **NO RADIUS:** Manually force the turn radius at the waypoint to be zero. This forces the inbound course and outbound course to go directly to and from the waypoint regardless of the amount of course change required. It is not possible to actually track a "NO RADIUS" path perfectly, but the FMS

path guidance quickly recaptures the outbound course after automatic waypoint sequencing. Designating a waypoint as a “NO RADIUS” waypoint affects the turn radius used to calculate procedure turn and holding pattern leg paths.

- 5) **VFR APP:** If the selected waypoint is a user waypoint with an approach bearing, a VFR approach to the user waypoint based upon the approach bearing is created, and the user waypoint is suppressed. If the selected waypoint is a VFR airport or an IFR airport with surveyed runways, the pilot is presented with a selection list of runways. After selecting a runway, a VFR approach to the runway is created, and the airport waypoint is suppressed. Activating a VFR approach automatically deletes any pre-existing IFR or VFR approaches. If a heading bug is not already active, activating a VFR approach automatically activates the heading bug on current aircraft heading and used to define the course intercept angle.
- 6) **IFR APP:** If the selected waypoint is an airport with an IFR approach, this option is available. Upon selecting this option, the pilot is presented with a selection list of available approaches including, if applicable, the 5-digit channel number, followed by a selection list of available transitions (if there are more than one), and a selection list of runways (if there are surveyed runways at the airport). After selection, the appropriate IFR approach is created, and the airport waypoint is suppressed. Activating an IFR approach automatically deletes any pre-existing IFR or VFR approaches. If there is a pre-existing STAR to the airport, the IFR approach waypoints are inserted after the STAR waypoints. If a heading bug is not already active, and the activated transition is “Vectors to Final”, activating an IFR approach automatically activates the heading bug on current aircraft heading for purposes of defining the course intercept angle.
- 7) **STAR:** If the selected waypoint is an airport with a STAR, this option is available. Upon selecting this option, the pilot is presented with a selection list of available STARs, followed by a selection list of available transitions (if there are more than one), and a selection list of runways (if there are surveyed runways at the airport). After selection, the appropriate STAR is created. Activating a STAR automatically deletes any pre-existing STAR. If there is a pre-existing approach (IFR or VFR) to the airport, the STAR waypoints are inserted prior to the approach waypoints.

- 8) **DP:** If the selected waypoint is an airport with a DP, this option is available. Upon selecting this option, the pilot is presented with a selection list of DPs, followed by a selection list of available transitions (if there are more than one), and a selection list of runways (if there are surveyed runways at the airport and more than one runway is authorized for the DP). After selection, the appropriate DP is created and, upon activation, automatically deletes any pre-existing DPs.

5.9.2. Active Flight Plan (ACTV) Menu Options

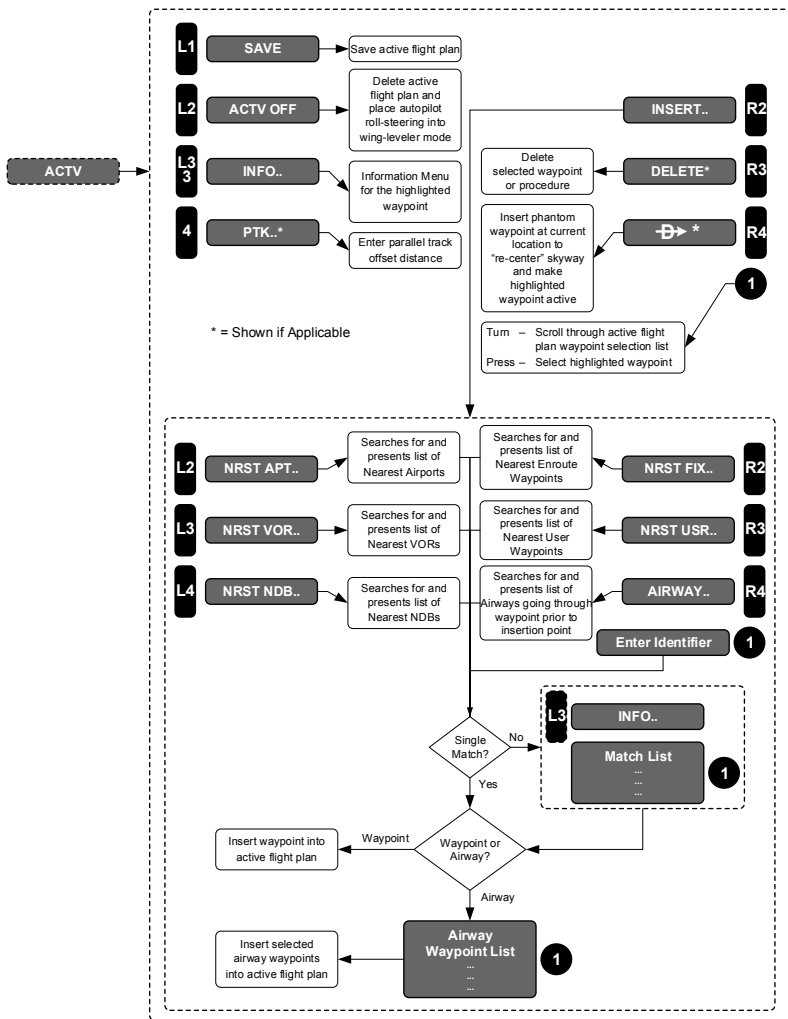


Figure 5-20: Active Flight Plan Menu Options

Various options appear at the same menu level as the nav log selection list. These options allow various modifications to be made to the active flight plan as follows:

- 1) **SAVE (L1)**: Saves active flight plan. Stored flight plans are saved without procedures or phantom waypoint (this is a safety item as procedures potentially change every 28 days). Stored flight plans are named by their first and last waypoints. If the new stored flight plan has the same start and end points as a previously saved flight plan but has different routing, a number (0-9) is appended to the name to uniquely identify up to 10 routings with the same start and end points.
- 2) **ACTV OFF (L2)**: Deletes active flight plan. The pilot is prompted to confirm deletion prior to completion of the operation.
- 3) **INFO (L3)**: Activates information menu option for the highlighted waypoint.
- 4) **PTK (L4)**: Shown if the active leg can be offset allowing the pilot to specify a parallel offset distance that applies to the active and contiguous legs. The range of parallel offsets are from 20NM left of track to 20NM right of track in 1NM increments.
- 5) **INSERT/ADD (R2)**: Allows the pilot to insert or add a waypoint or airway into the active flight plan. If the highlighted position is one position past the end of the active flight plan, the tile reads **ADD**, otherwise the tile reads **INSERT**. When the highlighted waypoint is the second or subsequent waypoint of a procedure, the tile does not appear. This prevents corruption of IFR approaches, STARS, and DPs. When activated, the pilot is prompted to enter an identifier. Performing a search for waypoints requires the entry of at least two characters. If only one character is entered, only airways are searched.

For waypoints, if there is a single result from the search, the result is inserted or added to the active flight plan. If there is no result from the search, the pilot is re-prompted to enter an identifier. If there are multiple results from the search, a selection list with matching identifiers is presented and, upon selection, the selected waypoint is inserted or added to the active flight plan. **INFO (L3)** appears at this level to aid in selection and give access to information for the highlighted result.

For airways, a search is performed for all airways going through the highlighted waypoint and matching the entered identifier (i.e., to get a list of all Victor airways, Q-Routes and T-Routes going through the highlighted waypoint, enter an identifier string of "V", "Q" or "T"). If there is a single result from the search, a list

of airway waypoints is shown for the pilot to select the desired exit point. If there is no result from the search, the pilot is re-prompted to enter an identifier. If there are multiple results from the search, a selection list with matching airway identifiers is presented and, upon selection, a list of airway waypoints is shown for the pilot to select the desired exit point. Upon selecting the desired exit point, all airway waypoints from the previous waypoint to the desired exit point are inserted or added to the active flight plan.

- 6) **NRST APT (L2)**: Performs a search for 20 airports within 240NM nearest to the waypoint prior to the insertion point or, if there is no waypoint prior to the insertion point, current aircraft location. If there are no results (i.e., no airports within 240NM with a runway length greater than or equal to the minimum runway length setting), **NO RESULTS** is displayed. Otherwise, a selection list is displayed including identifier, bearing, and distance to each result. Upon selecting a result from the selection list, the item is inserted or added to the flight plan. **INFO (L3)** appears at this level to aid in selection and give access to information for the highlighted result, which includes datalinked weather information when available. With optional datalink, **WX LGND (L2)** and **EXPND WX (L3)** are available at this level to show a weather symbol legend and highlighted result METAR and TAF text respectively.
- 7) **NRST FIX (R2)**: Performs a search for 20 fixes within 240NM nearest to the waypoint prior to the insertion point or, if there is no waypoint prior to the insertion point, current aircraft location. If there are no results (i.e., no fixes within 240NM), **NO RESULTS** is displayed. Otherwise, a selection list is displayed including identifier, bearing, and distance to each result. Upon selecting a result from the selection list, the item is inserted or added to the flight plan. **INFO (L3)** appears at this level to aid in selection and give access to information for the highlighted result.
- 8) **NRST NDB (L4)**: Performs a search for 20 NDBs within 240NM nearest to the waypoint prior to the insertion point or, if there is no waypoint prior to the insertion point, current aircraft location. If there are no results (i.e., no NDBs within 240NM), **NO RESULTS** is displayed. Otherwise, a selection list is displayed including identifier, bearing, and distance to each result. Upon selecting a result from the selection list, the item is inserted or added to the flight plan. **INFO (L3)** appears at this level to aid in


selection and give access to information for the highlighted result.

- 9) **NRST USR (R3)**: Performs a search for 20 user waypoints within 240NM nearest to the waypoint prior to the insertion point or, if there is no waypoint prior to the insertion point, current aircraft location. If there are no results (i.e., no user waypoints within 240NM), **NO RESULTS** is displayed. Otherwise, a selection list is displayed including identifier, bearing, and distance to each result. Upon selecting a result from the selection list, the item is inserted or added to the flight plan. **INFO (L3)** appears at this level to aid in selection and give access to information for the highlighted result.
- 10) **NRST VOR (L3)**: Performs a search for 20 VORs within 240NM nearest to the waypoint prior to the insertion point or, if there is no waypoint prior to the insertion point, current aircraft location. If there are no results (i.e., no VORs within 240NM), **NO RESULTS** is displayed. Otherwise, a selection list is displayed including identifier, bearing, and distance to each result. Upon selecting a result from the selection list, the item is inserted or added to the flight plan. **INFO (L3)** appears at this level to aid in selection and give access to information for the highlighted result.

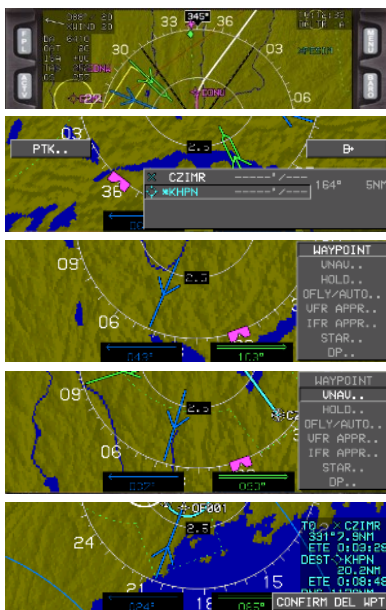
Identifier Entry Box: The pilot may enter an identifier. Performing a search for waypoints requires the entry of at least two characters. If there is a single result from the search, it is inserted or added to the active flight plan. If there is no result from the search, the pilot is re-prompted to enter an identifier. If there are multiple results from the search, a selection list with matching identifiers is presented and, upon selection, the selected waypoint is inserted or added to the active flight plan. **INFO (L3)** appears at this level to aid in selection and give access to information for the highlighted result, which includes datalinked weather information when available. With optional datalink, **WX LGND (L2)** and **EXPND WX (L3)** are available at this level to show a weather symbol legend and highlighted result METAR and TAF text respectively.

- 11) **DELETE (R3)**: Not shown if the highlighted waypoint is a parallel offset entry or exit waypoint (these types of waypoints are deleted by removing the parallel offset). Otherwise, if the highlighted waypoint is a non-procedure waypoint, the function deletes the highlighted waypoint from the active flight plan. If the

highlighted waypoint is part of a procedure, the function deletes the entire procedure from the active flight plan. The pilot is prompted to confirm deletion prior to completion of the operation. This tile does not appear if the highlighted waypoint is a non-procedure waypoint and there are fewer than three non-procedure waypoints in the active flight plan. This is because an active flight plan must always have at least two non-procedure waypoints. The tile also does not appear when the highlighted waypoint is suppressed or when the highlighted position is one position past the end of the active flight plan.

- 12) **Direct**  **(R4)**: Not shown if the highlighted waypoint is a parallel offset entry or exit waypoint. Otherwise, inserts a phantom waypoint at the current aircraft location and makes the highlighted waypoint active. The phantom waypoint is a fly-over defined entry waypoint, and the leg prior to the phantom waypoint is designated a discontinuity. This assures the skyway is “re-centered” to provide guidance to the new active waypoint. This tile does not appear when the highlighted waypoint is suppressed or when the highlighted position is one position beyond the end of the active flight plan.

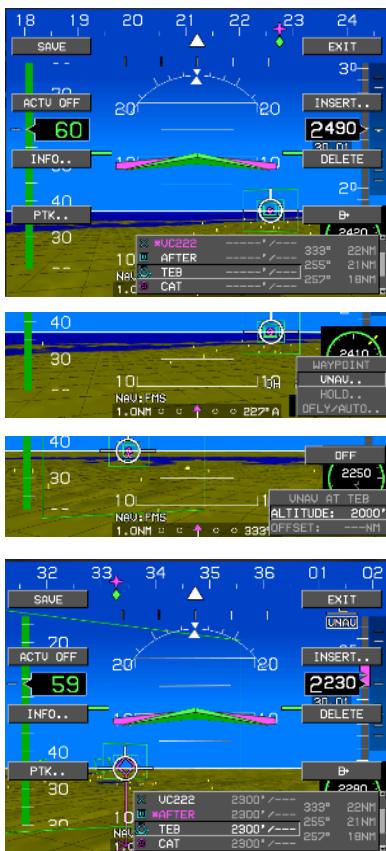
5.9.3. Active Flight Plan (ACTV) Menu Options (Step-By-Step)



- 1) Press **ACTV (L2)** to view current Active Flight Plan.
- 2) Scroll **1** to desired waypoint and push to enter.
- 3) Scroll **1** to desired option and push to enter.
- 4) As one option, a VNAV setting is entered.
- 5) As another option, deleting the next waypoint is accomplished.

Figure 5-21: Active Flight Plan Menu Options (Step-By-Step)

5.9.4. Active Flight Plan (ACTV) Menu (Step-By-Step)



- 1) With the desired flight plan selected and activated, the next steps may be accomplished on the PFD or MFD.
- 2) Press **ACTV (L2)** to view ACTIVE flight plan.
- 3) Scroll **1** to desired waypoint option and push to enter.
- 4) Scroll **1** to **VNAV** then to desired altitude and push to enter.
- 5) If no **OFFSET** is necessary, push **1** to enter.
- 6) View ACTIVE flight plan for further editing or press **EXIT (R1)** to clear ACTIVE flight plan from view.

Figure 5-22: Active Flight Plan Menu (Step-By-Step)

5.9.5. Active Flight Plan (ACTV) Options NRST Menu Option (Step-By-Step)



1) With Active Flight Plan displayed, press **INSERT (R2)** to see NRST options.

2) Press **NRST APT (L2)**, **NRST VOR (L3)**, **NRST NDB (L4)**, **NRST FIX (R2)**, **NRST USR (R3)**, or **AIRWAY (R4)** to view applicable list. Scroll **⬇** to desired selection and push to insert into ACTIVE flight plan.



3) If desired, press **SAVE (L1)** to save this active flight plan as one of the 100 stored flight plans. (Any procedure within the saved active flight plan is not saved).

Figure 5-23: Active Flight Plan Options NRST Menu Option (Step-By-Step)

5.9.6. Active Flight Plan (ACTV) Menu (AW-109SP)

The current active waypoint is the lateral navigation color, as defined in Table 3-10: AW-109SP Lateral Navigation Color Logic.

If a valid MOT flight pattern has been received from the AFCS and is being used as the current active flight plan, the Active Flight Plan Menu is disabled.

5.10. Information (INFO) Menu

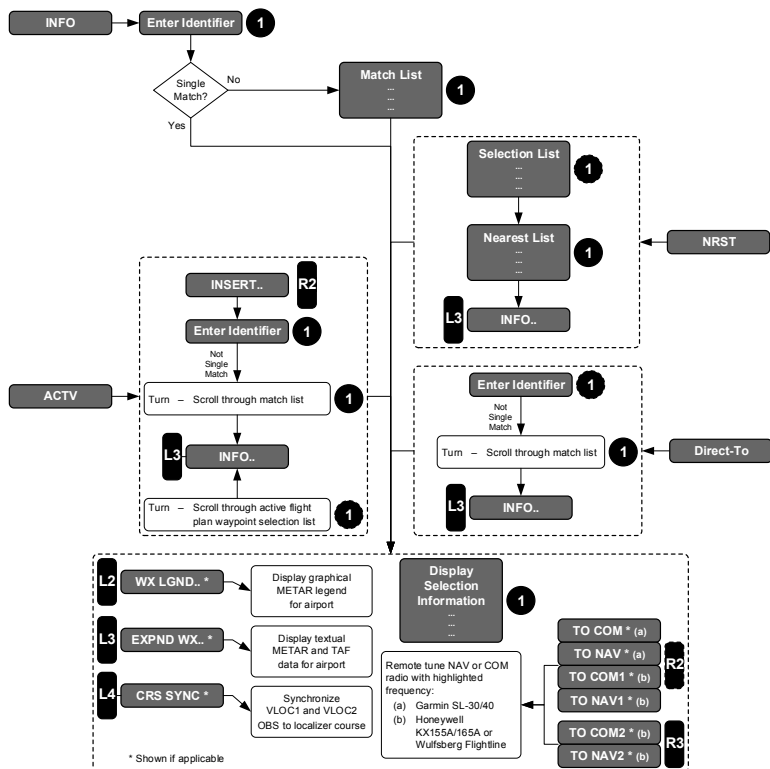


Figure 5-24: Information Menu

If **INFO** is activated from within the **ACTV**, **NRST**, or **Direct** menu, information on the highlighted waypoint from the applicable selection list is shown directly. Otherwise, the function checks for a current active waypoint. If there is an active waypoint, the active waypoint becomes the default entry. If there is no active waypoint, the nearest airport becomes the default entry. If the default entry is accepted, information for the default entry is shown. If the pilot rejects the default entry by entering identifier characters, a search for matching identifiers is performed. If there is a single result from the search, information for the result is shown. If there is no result from the search, the pilot is re-prompted to enter an identifier. If there are multiple results from the search, a selection list with matching identifiers is presented for the pilot to select the desired identifier.

The amount and type of information presented depends upon the type of waypoint as follows:

- | | |
|-----------------------------|-------------------------------|
| 1) Waypoints | 7) Latitude/Longitude |
| 2) Identifier | 8) Navigation aides |
| 3) Type | 9) Frequency |
| 4) Elevation (if available) | 10) Airports |
| 5) Long name | 11) Communication frequencies |
| 6) Bearing and distance | 12) Runway data |

For remote tuning, a single frequency is associated with the waypoint, tiles allow transmission of the frequency to remote NAV or COM radios. **TO COM1** or **TO NAV1 (R2)** while a **TO COM2** or **TO NAV2 (R3)** is shown. If more than one frequency is associated with the waypoint (i.e., airport waypoint), tiles are shown to allow transmission of a frequency to remote NAV or COM radios when a frequency is highlighted in the **INFO** block. If the frequency is less than 118MHz, the tiles read **TO NAV#**, and the transmission is addressed to NAV radios. If the frequency is greater than or equal to 118MHz, the tiles read **TO COM#**, and the transmission is addressed to COM radios.

NOTE:

Frequencies are only sent to either com or nav radios in the standby position. It is up to the pilot to swap frequencies to the active position in the applicable radio.

When the information is presented for an ILS or localizer waypoint and the current VLOC1 or VLOC2 omnibearing selectors are not synchronized with the localizer course, **CRS SYNC (L4)** allows one-touch synchronization of **VLOC1 (L3)** and **VLOC2 (L4)** omnibearing selectors to the localizer course (see Figure 5-25).



Figure 5-25: CRS SYNC

5.10.1. Information (INFO) Menu (Step-By-Step)



- 1) Press **INFO (L3)** to view current active waypoint.
- 2) Push **1** to view information.

Figure 5-26: Information (Step-By-Step)

5.10.2. Information (INFO) Menu (AW-109SP)

If Swiss Grid mode is active, waypoint information shows X, Y, and Z Swiss Grid parameters instead of latitude and longitude.

CAUTION:

Swiss Grid should not be used outside of Switzerland.

5.11. Omnibearing Selector (OBS) Menu

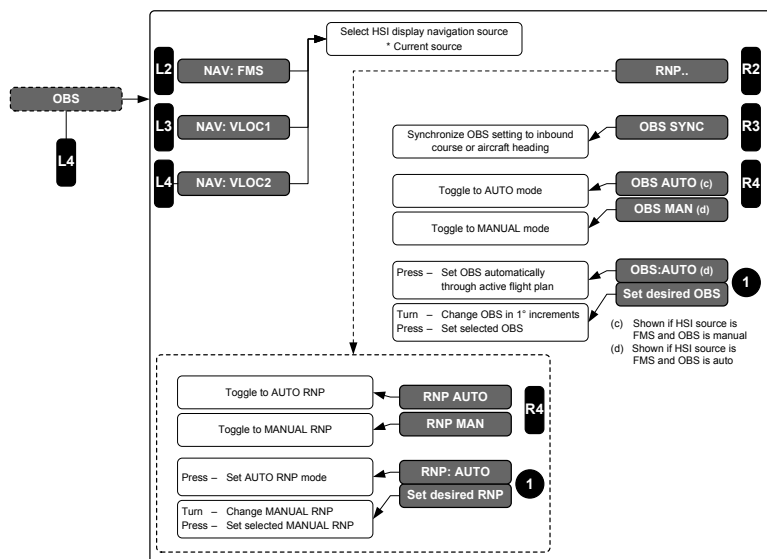


Figure 5-27: Omnibearing Selector (OBS) Menu

The OBS menu allows the pilot to control the setting of the omnibearing selector for purposes of showing course deviations. The OBS for **FMS (L2)** allows the pilot to specify either a manual or automatic OBS setting in which the current active OBS is controlled by the active flight plan. The OBS for **VLOC1** allows the pilot to specify the active OBS setting for the VLOC1 navigation function. The OBS for **VLOC2** allows the pilot to specify the active OBS setting for the VLOC2 navigation function. Manual **FMS**, **VLOC1**, and **VLOC2 OBS** settings are settable in increments of 1°. **OBS SYNC (R3)** is available to synchronize the Manual **FMS**, **VLOC1**, or **VLOC2 OBS** settings (depending upon HSI source) to the inbound course or, if the inbound course cannot be determined, to aircraft heading. When HSI source is **FMS**, **OBS AUTO/OBS MAN (R4)** is available to toggle between automatic and manual OBS settings.

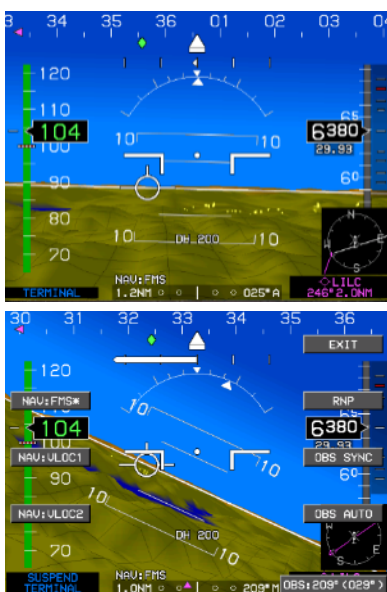
With VOR symbology enabled, the OBS function permits the pilot to select either **FMS**, **VLOC1**, or **VLOC2** as the HSI source. The HSI source selects the navigation source used to generate HSI guidance symbology. The OBS function also permits the pilot to select

between manual and automatic RNP settings. Upon selecting **RNP**,

RNP AUTO/RNP MAN (R4) is available to toggle between automatic and manual RNP settings. Manual RNP is selectable between 0.10NM and 15NM as follows:

- 1) 0.01NM increments between RNP 0.10 and RNP 0.3
- 2) 0.1NM increments between RNP 0.3 and RNP 2
- 3) 1NM increments between RNP 2 and RNP 15

5.11.1. Omnibearing Selector (OBS) Menu (Step-By-Step)



- 1) Before pressing **OBS** (L4) to make any OBS changes, view the current setting to see if **FMS** is selected.
- 2) Press **OBS** (L4) and make HSI source selection or change to **OBS MANUAL** (R4).

Figure 5-28: Omnibearing Selector (OBS) (Step-By-Step)

5.11.2. Omnibearing Selector (OBS) Menu (AW-109SP)

If the AFCS is in NAV mode, press **OBS** (L4) to display the following choices for selecting a NAV Preview source: **PRV:VLOC1** and **PRV:VLOC2**. These tiles appear instead of the normal **NAV:VLOC1** and **NAV:VLOC2**. While the AFCS is in NAV mode, it only couples to FMS and cannot couple to either **VLOC1** or **VLOC2**. The NAV

Preview Status (set by selecting one of the NAV preview sources as described above) is synchronized on-side only.

5.12. Heading Bug (HDG) Menu

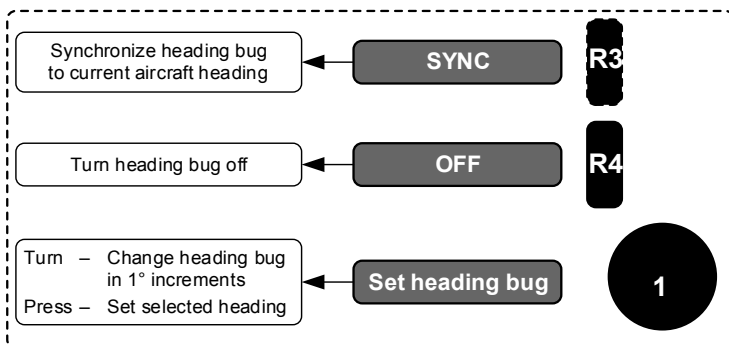


Figure 5-29: Heading Bug (HDG) Menu

The heading bug menu allows the pilot to set the heading bug in increments of 1°, synchronize the heading bug to current heading, or turn off the heading bug.

5.12.1. Heading Bug (HDG) Menu (PFD Only) (Step-By-Step)



- 1) Scroll **1** to enter Heading mode.
- 2) Scroll **1** to change heading bug in 1° increments.
- 3) Push **1** to select new heading or press **SYNC (R3)** to sync current heading.

Figure 5-30: Heading Bug (HDG) Menu (Step-By-Step)

5.12.2. Heading Bug (HDG) Menu (AW-109SP)

The heading bug is set with the RBP, thus the Heading Bug Menu is disabled on the IDU.

5.13. Nearest (NRST) Menu

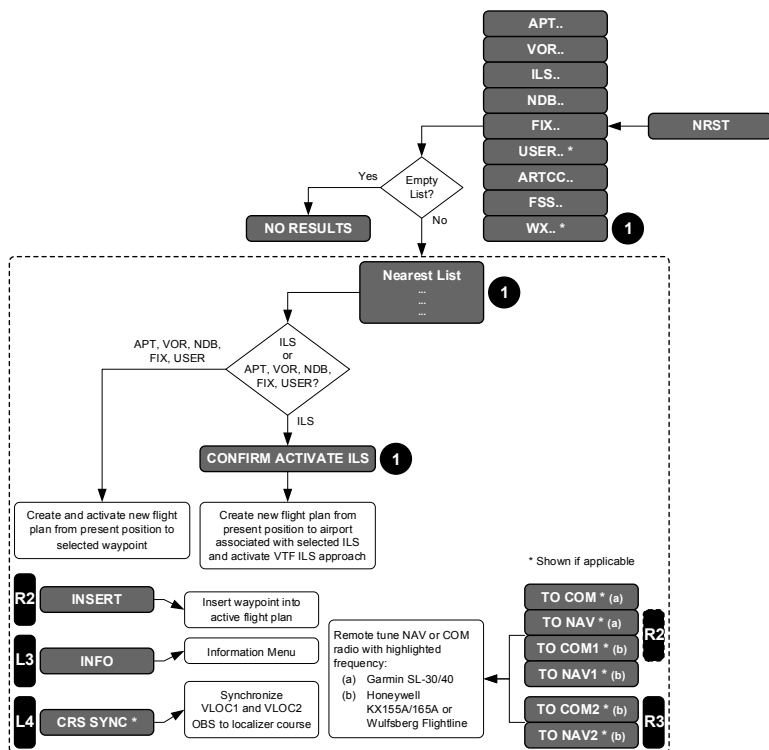


Figure 5-31: Nearest (NRST) Menu

Upon activating the nearest menu, an option list appears to allow the pilot to select from a list of the nearest following categories:

- | | | |
|-------------|-------------------|----------------------|
| 1) Airports | 4) NDBs | 7) ARTCC frequencies |
| 2) VORs | 5) Fixes | 8) FSS frequencies |
| 3) ILSs | 6) User waypoints | 9) Weather |

Upon selecting a category from the option list, a selection list of up to 20 items within 240NM matching the category appears. If the list is empty (i.e., no items within 240NM), **NO RESULTS** is displayed. The selection list includes identifier, bearing, and distance to the item, and the list for airports also contains an indication of the

longest runway length at the airport. The selection lists for airports contains only airports with runway length greater than or equal to the minimum runway length setting when the system was configured during installation.

The selection list for airports, VORs, ILSs, NDBs, ARTCCs, and FSSs includes an associated frequency (CTAF in the case of airports). Tiles are shown to allow transmission of the associated frequency to remote NAV or COM radios. If the frequency is greater than or equal to 118MHz, the tiles read **TO COM#** and the transmission is addressed to COM radios. If the frequency is less than 118MHz, the tiles read **TO NAV#**, and the transmission is addressed to NAV radios, **TO COM1** or **TO NAV1 (R2)**, or a **TO COM2** or **TO NAV2 (R3)** position.

NOTE:

Frequencies are only sent to either com or nav radios in the standby position. It is up to the pilot to swap frequencies to the active position in the applicable radio.

When the results for airports, VORs, ILSs, NDBs, fixes, and user waypoints are displayed, **INFO (L3)** is available to activate the information function and provide further information on the highlighted item.

In the case of **NRST ILS** where the current VLOC1 or VLOC2 OBS does not match the localizer course, **CRS SYNC (L4)** is presented to synchronize VLOC1 and VLOC2 OBS to the localizer course.

Upon selecting a waypoint of type airport, VOR, NDB, fix, or user waypoint, a new active flight plan is created from present aircraft position to the selected waypoint. Upon selecting a waypoint of type ILS, **CONFIRM ACTIVATE ILS** is displayed. When the pilot confirms the ILS activations, the following actions occur:

- 1) A direct flight plan to the airport associated with the ILS is created;
- 2) A vectors-to-final ILS approach to the ILS is activated;
- 3) If the heading bug is turned OFF, the heading bug is activated to current heading to act as a starting point for receiving vectors (autopilot enabled systems only);

- 4) The VLOC1 and VLOC2 OBS settings are set to the associated localizer course;
- 5) HSI source is switched as follows:
 - a) If there is only one nav radio installed, the source for the selecting side is changed to VLOC1. The source for the other side does not change.
 - b) If there are two nav radios installed, the default sensor for the selecting side controls which source is used. The source for the other side does not change.
- 6) Connected nav radios are remote tuned to ILS frequency.

5.13.1. Nearest (NRST) Menu (Step-By-Step)



- 1) Press **NRST (R3)** to enter Nearest Menu.
- 2) Scroll **1** to select **APT** from list push to enter.
- 3) Scroll **1** to desired airport and select to either **INSERT**, **INFO**, or send frequency to **COMM1** or **COMM2**.

Figure 5-32: Nearest (NRST) Menu (Step-By-Step)

5.13.2. Nearest ILS (NRST) Menu (Step-By-Step)



1) Press **NRST (R3)** to enter Nearest Menu.

2) Scroll **1** to select ILS from list then push to enter.



3) Scroll **1** to desired airport and ILS approach, then push to select and enter.

4) Push to confirm and activate ILS.



Figure 5-33: Nearest (NRST) Menu ILS

5.14. Direct Menu

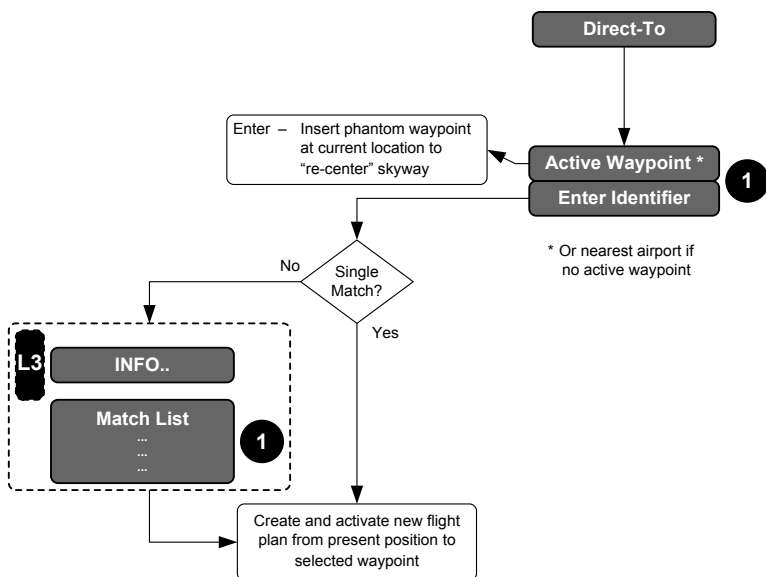


Figure 5-34: Direct Menu

Upon activating the direct menu from the top-level menu, the function checks for a current active waypoint and, if found, the active waypoint becomes the default entry. If there is no active waypoint, the nearest airport becomes the default entry.

If the default entry is the active waypoint and accepted by the pilot, a phantom waypoint is inserted at the current aircraft location. The phantom waypoint is a fly-over defined entry waypoint, and the leg prior to the phantom waypoint is designated a discontinuity. This assures the skyway is “re-centered” to provide guidance to the new active waypoint. The rest of the active flight plan remains unchanged.

If the default entry is not the active waypoint and accepted by the pilot, the resulting action depends upon whether the aircraft is in the air or on the ground. If in the air, a new active flight plan is created from present aircraft position to the selected waypoint. If on the ground, a search is conducted for a database airport within 6NM. If an airport is found, a new active flight plan is created from the found

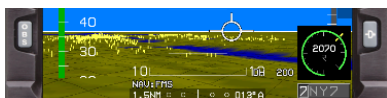
airport to the selected waypoint. Otherwise, a new active flight plan is created from present aircraft position to the selected waypoint.

If the pilot rejects the default entry by entering identifier characters, a search for matching identifiers is performed. If there is a single result from the search, the resulting action depends upon whether the aircraft is in the air or on the ground. If in the air, a new active flight plan is created from present aircraft position to the selected waypoint. If on the ground, a search is conducted for a database airport within 6NM. If an airport is found, a new active flight plan is created from the found airport to the selected waypoint. Otherwise, a new active flight plan is created from present aircraft position to the selected waypoint.

If there is no result from the search, the pilot is re-prompted to enter an identifier.

If there are multiple results from the search, a selection list with matching identifiers is presented. Upon selection, the resulting action depends upon whether the aircraft is in the air or on the ground. If in the air, a new active flight plan is created from present aircraft position to the selected waypoint. If on the ground, a search is conducted for a database airport within 6NM. If an airport is found, a new active flight plan is created from the found airport to the selected waypoint. Otherwise, a new active flight plan is created from present aircraft position to the selected waypoint. **INFO (L3)** appears at this level to aid in selection and give access to the information function for the highlighted result.

5.14.1. Direct Menu (Step-By-Step)




- 1) Press  (**R4**) to enter the Direct menu.
- 2) The current active waypoint or, in the absence of an active waypoint, the nearest airport appears.
- 3) Either push **1** to insert a phantom waypoint at the current aircraft location or scroll **1** to begin entering new identifier.
- 4) After creating new identifier, scroll **1** to the end and push to enter. A new active flight plan is created from the present aircraft position.
- 5) If necessary, a search of waypoints appears for a selection. Scroll **1** to desired selection and push to enter.

Figure 5-35: Direct Menu (Step-By-Step)

5.15. Timer (TIMER) Menu

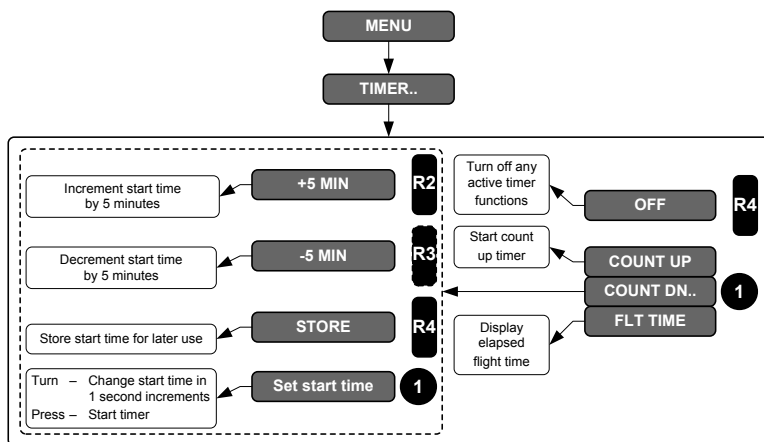



Figure 5-36: Timer Menu

Upon selecting the timer menu, an option list appears to let the pilot choose the count up, countdown timer, or the flight time display.

OFF  (R4) is present to turn off any active timer functions.

If the pilot selects the count up timer, the count up timer is activated. If the pilot selects the countdown timer, the pilot is prompted to enter a start time from which the countdown begins. Shortcut tiles to quickly add or decrement by five minute increments are provided at this level. After entering a start time, the pilot may either start the

countdown timer or select **STORE**  (R4) to store the start time for later use.

If the pilot selects the flight time display option, the current elapsed time since the aircraft transitioned from ground to air mode is displayed for ten seconds or until any button is pressed. If the aircraft has not yet transitioned from ground to air mode, upon selecting the flight time display option, the elapsed time is displayed as **FLT TM: 00:00:00**.

5.15.1. Timer (TIMER) Menu (Step-By-Step)



- 1) Press **MENU (R1)**.
- 2) Press **TIMER (L4)** to enter the Timer menu.
- 3) Scroll **1** to select **COUNT UP**, **COUNT DN..**, or **FLT TIME**, and push to enter.
- 4) If **COUNT UP** is desired, push **1** to enter. A timer appears on the PFD area above the pitch scale.
- 5) To turn off timer, press **MENU (R1)** and **TIMER (L4)** then press **OFF (R4)** on PFD or MFD.

Figure 5-37: Timer Menu (Step-By-Step)

5.16. PFD Source (SOURCE) Menu

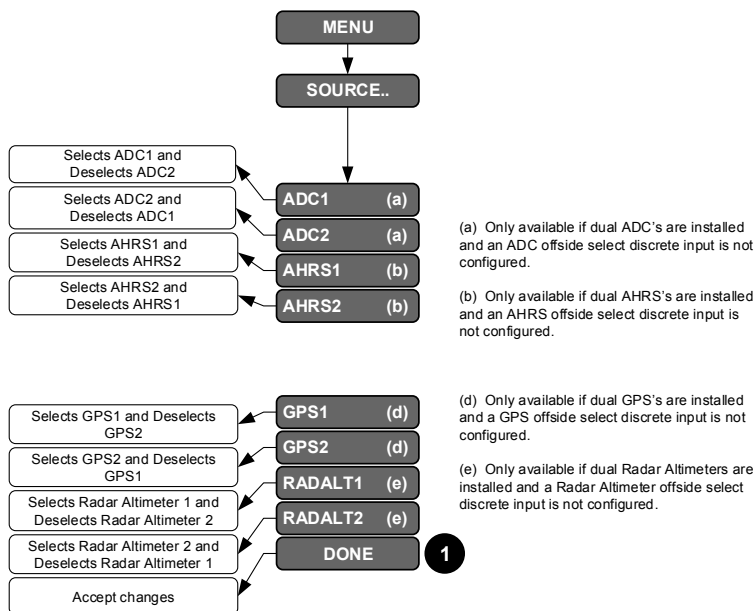


Figure 5-38: PFD Source Menu

Upon activating the PFD source menu, an option list of sensor sources is shown for the pilot to select/deselect the following items:

- 1) ADC1,
- 2) ADC2,
- 3) AHR1,
- 4) AHR2,
- 5) GPS1,
- 6) GPS2,
- 7) Radar Altimeter 1, and
- 8) Radar Altimeter 2

5.16.1. PFD Page First-Level Source Selection (Step-By-Step)



- 1) Press **MENU (R1)**.
- 2) Press **SOURCE (L2)**.
- 3) Scroll **⬇** to check desired source, push to check, scroll to **DONE**, and push to enter.

Figure 5-39: PFD Page First-Level Source Selection (Step-By-Step)

5.17. PFD Bugs (BUGS) Menu (N/A for AW-109SP)

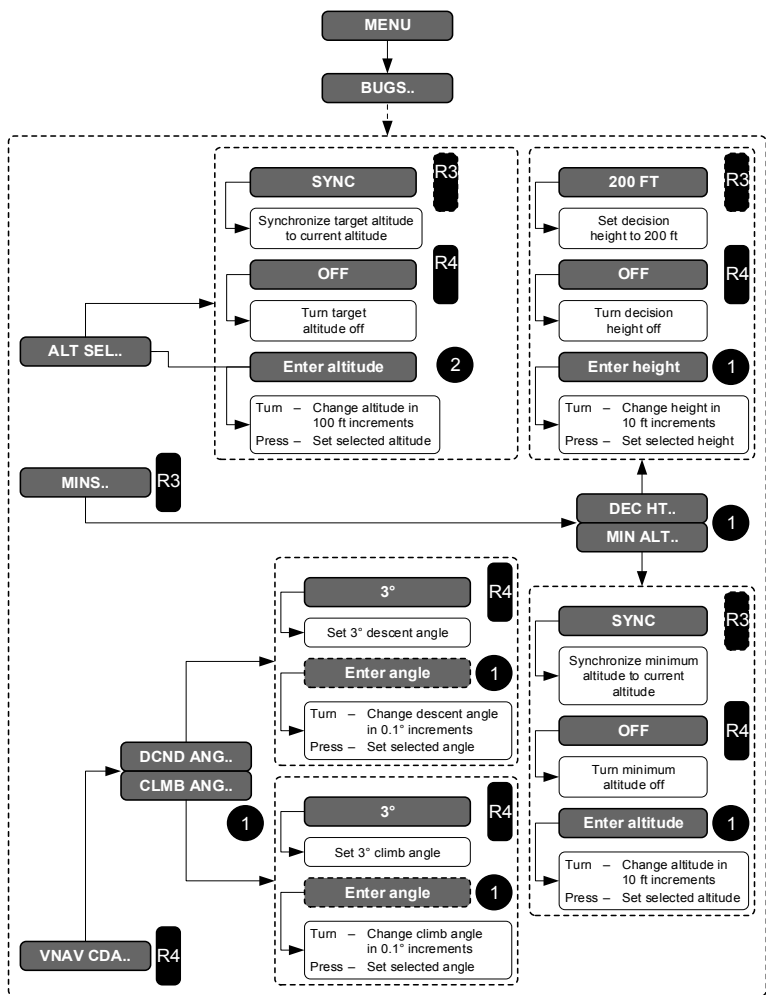
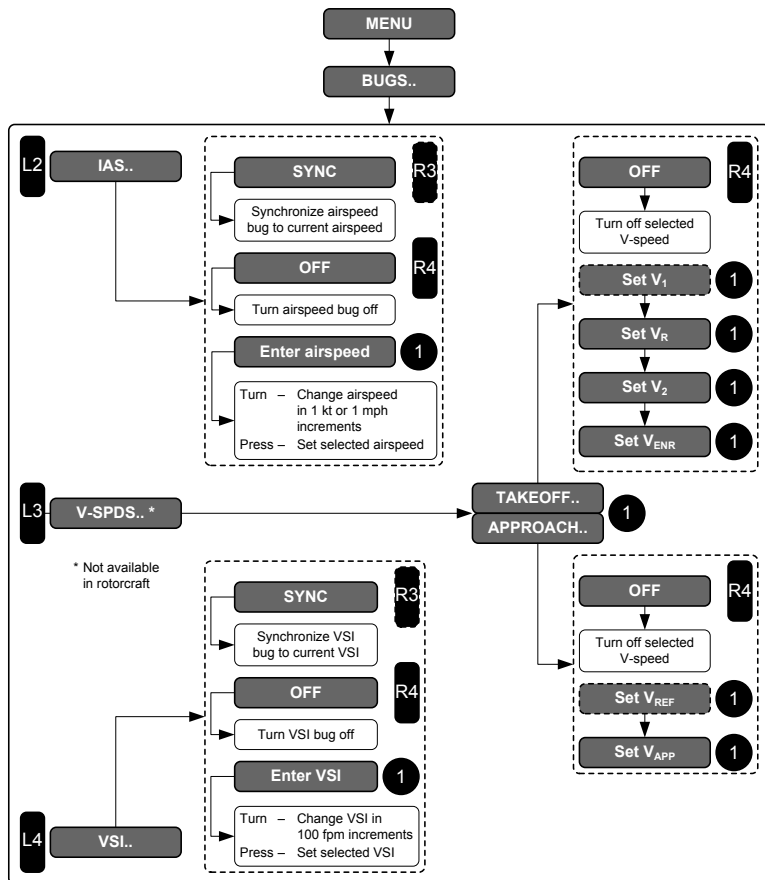



Figure 5-40: PFD Bugs (BUGS) Menu (N/A for AW-109SP)



**Figure 5-41: PFD Bugs (BUGS) Menu (N/A for AW-109SP)
(Continued)**

Upon selecting the PFD Bugs menu, set either minimums (**MINS**) (**R3**), an airspeed bug (**IAS**) (**L2**), the VNAV climb or descent angle (**VNAV CDA**)  (**R4**), or vertical speed (**VSI**) (**L4**).

Selecting the minimums option brings up a further option list for setting either decision height or minimum altitude. Selecting the minimum altitude option allows the pilot to either synchronize the minimum altitude to current altitude, turn the minimum altitude off, or set the minimum altitude in increments of 10 feet. The decision

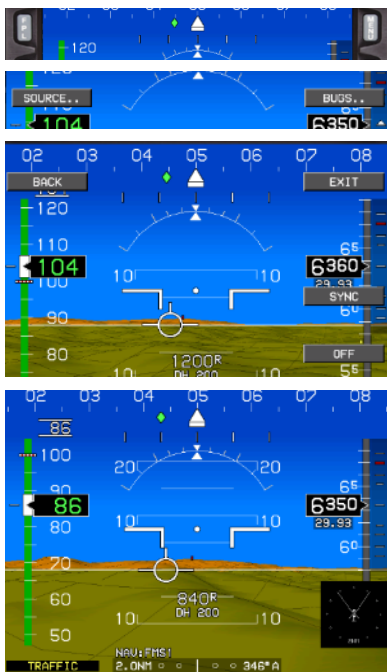
height option allows the pilot to either, set the decision height to a default height of 200 feet, turn the decision height off, or set the decision height in increments of 10 feet.

Selecting the airspeed bug option allows the pilot to either, synchronize the airspeed bug to current airspeed, turn the airspeed bug off, or set the airspeed bug in increments of one knot indicated airspeed. On the low end, airspeed bug settings are no less than 60KIAS and no greater than **VNE**.

Selecting the VNAV climb or descent angle option brings up a further option list for setting either climb angle or descent angle. At this further level, selecting either option allows the pilot to set the climb angle or the descent angle (as appropriate) in increments of 0.1° (a value of 0 is not allowed). Corresponding feet per nautical mile are shown adjacent to the climb or descent angle setting in parentheses. In addition, a shortcut tile is available to set the climb or descent angle to 3°.

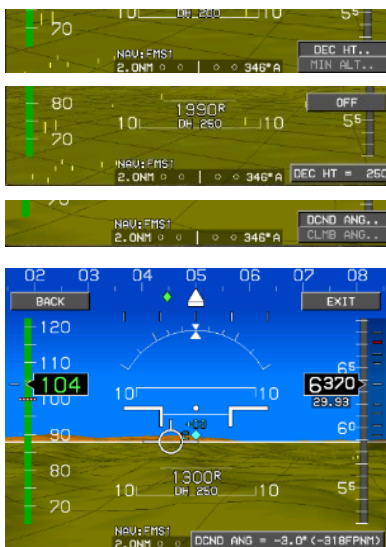
Selecting the VSI bug option allows the pilot to either, synchronize the VSI bug to the current VSI, turn the VSI bug off, or set the VSI bug in increments of 100 feet per minute. The airspeed bug and VSI bug are mutually exclusive, therefore selecting one turns off the other.

5.17.1. PFD Bugs Menu (BUGS) Menu (Step-By-Step)



- 1) Press **MENU (R1)** then **BUGS (R2)** to enter the Bugs menu.
- 2) Press either **IAS (L2)**, **VSI (L4)**, **MINS (R3)**, or **VNAV CDA (R4)** to select desired menu.
- 3) If **IAS (L2)** was entered, press **SYNC (R3)** or **OFF (R4)** to accept or turn off IAS bug.
- 4) If a different **IAS** bug is desired, scroll **⬇** to select desired airspeed and push to enter new value.

Figure 5-42: PFD Bugs Menu (Step-By-Step) (N/A for AW-109SP)



- 1) If **MINS (R3)** was selected, scroll **1** to select either **DEC HT..** or **MIN ALT..** and push to enter.
- 2) If **DEC HT..** was selected, scroll **1** to create new decision height and push to enter.
- 3) The new DH displays on the PFI area below the FPM.
- 4) If **VNAV CDA (R4)** was selected, scroll **1** to select either **DCND..** or **CLIMB..** and push to enter.
- 5) If **DCND..** was selected, Scroll **1** to create the descent angle.
- 6) Push **1** to enter new descent angle or select default 3° (**R4**).

Figure 5-43: PFD Bugs (Step-By-Step) (N/A for AW-109SP)

5.18. PFD Bugs (BUGS) Menu (AW-109SP)

All applicable bugs are set with the Remote Bugs Panel. Thus, the entire PFD Bugs Menu is disabled.

5.19. Remote Bugs Panel

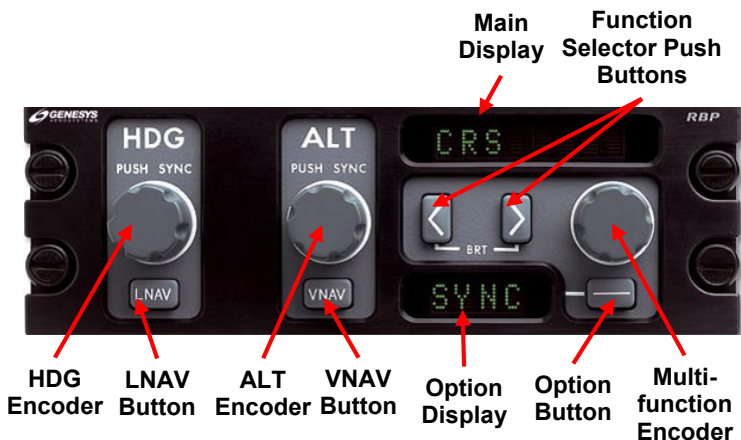


Figure 5-44: Remote Bugs Panel

The Remote Bugs Panel (RBP) provides dedicated controls for frequently needed bugs and additional controls for setting IDU parameters such as defined in Table 5-4: Remote Bugs Panel (RBP).

The RBP has an internal light sensor to control its own initial display and backlight brightness. Press the two arrow buttons simultaneously to gain access for brightness control and use the multifunction encoder to make brightness adjustments. Press the option button to exit the brightness control program and return the RBP to normal operation.

The design of this RBP promotes the ease of operation while minimizing pilot workload complexity. The HDG and ALT encoders behave exactly as the encoders on the IDU-450 where they appear during most screen configurations. During initialization, the RBP always begins with GENESYS RBP displayed on the main and option display screens.

Table 5-4: Remote Bugs Panel (RBP)

Button/Encoder	Function	Scroll	Press/Push
Heading Encoder	Heading Bug	Increment or decrement	Synchronize to current heading
Altitude Encoder	Altitude Bug	Increment or decrement	Synchronize target altitude to current altitude
Multifunction Encoder	GPS Course	Increment or decrement setting	Synchronize GPS course to current bearing to the active waypoint
Multifunction Encoder	VOR 1 Course	Increment or decrement setting	Synchronize VOR 1 course to the current bearing to the station
Multifunction Encoder	VOR 2 Course	Increment or decrement setting	Synchronize VOR 2 course to the current bearing to the station
Multifunction Encoder	Airspeed Bug	Increment or decrement setting	Synchronize to current airspeed
Multifunction Encoder	Vertical Speed Bug	Increment or decrement setting	Synchronize to current VSI
Multifunction Encoder	Climb Angle Set	Increment or decrement setting	Set Climb Angle to 3°
Multifunction Encoder	Descent Angle Set	Increment or decrement setting	Set Descent Angle to 3°
Multifunction Encoder	Decision Height Bug	Increment or decrement	Set Decision Height to 200' AGL

Table 5-4: Remote Bugs Panel (RBP)

Button/Encoder	Function	Scroll	Press/Push
Multifunction Encoder	Minimum Altitude Bug	Increment or decrement	Set to current altitude
Option “---“ Button	GPS Course	N/A	Change OBS mode (Manual or Automatic)
Option “---“ Button	VOR 1 Course	N/A	No Function
Option “---“ Button	VOR 2 Course	N/A	No Function
Option “---“ Button	Airspeed Bug	N/A	Toggle (On or Off)
Option “---“ Button	Vertical Speed Bug	N/A	Toggle (On or Off)
Option “---“ Button	Climb Angle Setting	N/A	No Function
Option “---“ Button	Descent Angle Setting	N/A	No Function
Option “---“ Button	Decision Height Bug	N/A	Toggle (On or Off)
Option “---“ Button	Minimum Altitude Bug	N/A	Toggle (On or Off)
Arrow Buttons	Function Scroll	N/A	Scroll through functions for the “set” Multi-Function Encoder. Press both arrow buttons simultaneously to place RBP into dimming mode

Table 5-4: Remote Bugs Panel (RBP)

Button/Encoder	Function	Scroll	Press/Push
VNAV Button	VNAV	N/A	Switch EFIS autopilot pitch steering and commanded VSI between VNAV sub-mode and target altitude sub-mode
LNAV Button	LNAV	N/A	Switch EFIS autopilot roll steering between LNAV sub-mode and heading sub-mode

5.20. Remote Bugs Panel (AW-109SP)

The RBP is used to select heading and altitude, transition into and out of FMS LNAV and VNAV Submodes, and to perform other miscellaneous functions as follows.

5.20.1. Heading Encoder

When pushed or scrolled, the heading encoder communicates with the AFCS. When the AFCS is in NAV mode and the EFIS is in FMS Heading Submode:

- 1) Push the heading encoder to synchronize the Heading Datum to the AFCS-controlled Heading Preselect;
- 2) Scroll the heading encoder while pushed to directly change the Heading Datum; and
- 3) Changing the Heading Datum causes the Heading Datum readout to be displayed on the PFD for five seconds.

The Heading Datum value is communicated to the AFCS.

5.20.2. Altitude Encoder (AW-109SP)

When pushed or scrolled, altitude encoder communicates with the AFCS. When the AFCS is in VNAV mode and the EFIS is in ALTA Submode:

- 1) Push the altitude encoder to synchronize the ALTA Datum to the AFCS-controlled Altitude Preselect; and
- 2) Scroll the altitude encoder while pushed to directly change the ALTA Datum.

The ALTA Datum value is communicated to the AFCS.

5.20.3. Multifunction Encoder

FMS OBS function is available:

- 1) On the Side in Command; OR
- 2) When Side in Command cannot be determined; OR
- 3) If not cross-linked; OR
- 4) When Side in Command is not using FMS as its NAV source.

VOR1 OBS function is available:

- 1) On the Side in Command; OR
- 2) When Side in Command cannot be determined; OR
- 3) When Side in Command is not using VOR1 as its NAV source.

VOR2 OBS function is available:

- 1) On the Side in Command; OR
- 2) When Side in Command cannot be determined; OR
- 3) When Side in Command is not using VOR2 as its NAV source.

The SPD bug function is disabled (it is driven by a control on the AFCS panel).

The VSI bug function is available when the AFCS is in VNAV mode with a VSI climb or VSI descent as the current vertical control law AND:

- 1) On the Side in Command; OR
- 2) When Side in Command cannot be determined.

The Climb Angle function is available:

- 1) On the Side in Command; OR
- 2) When Side in Command cannot be determined.

The Descent Angle function is available:

- 1) On the Side in Command; OR
- 2) When Side in Command cannot be determined.

Otherwise, there are no changes to the Multifunction Encoder functions.

5.20.4. LNAV Button (AW-109SP)

When the AW-109SP AFCS is in NAV mode, press the LNAV button to toggle the EFIS between LNAV Submode and HDG Submode. The EFIS toggles to LNAV Submode by turning OFF the heading bug. The EFIS toggles to HDG Submode by initializing the heading bug to either the AFCS-controlled Heading Preselect value (if valid) or aircraft heading. Upon engagement of HDG Submode, the Heading Datum readout is displayed on the PFD for five seconds.

5.20.5. VNAV Button (AW-109SP)

When the AW-109SP AFCS is in VNAV mode, press the VNAV button to toggle the EFIS between VNAV Submode and ALTA Submode. The EFIS toggles to VNAV Submode by turning off the ALTA bug. The EFIS toggles to ALTA Submode by initializing the ALTA bug to either ALTA preselect value (if valid) or VNAV altitude.

5.21. PFD Declutter (DCLTR) Menu

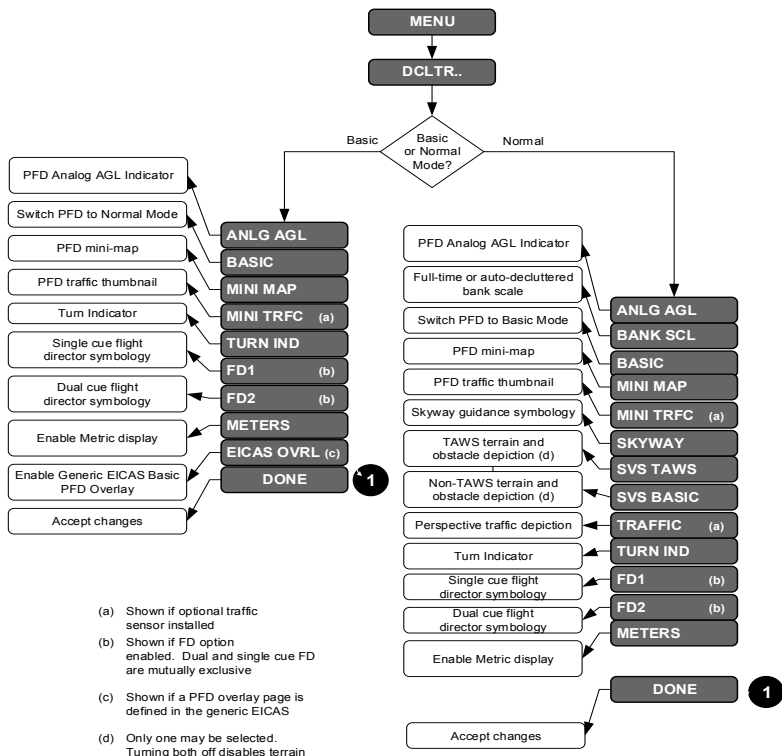


Figure 5-45: PFD Declutter (DCLTR) Menu

Upon activating the PFD declutter menu, an option list of declutter items is shown. In Normal Mode, the pilot may select or deselect the following items:

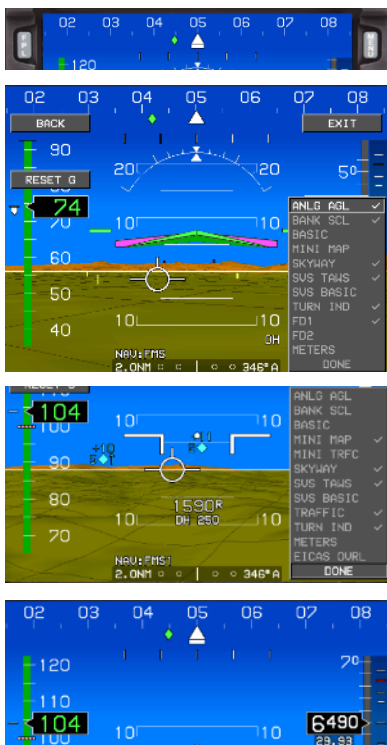
- 1) PFD analog AGL indicator;
- 2) Full-time or auto-decluttered bank scale display;
- 3) Basic Mode (switches PFD to Basic Mode);
- 4) PFD mini-map;
- 5) PFD traffic thumbnail;

- 6) Skyway guidance symbology;
- 7) Non-TAWS perspective terrain and obstacle depiction (mutually exclusive with TAWS perspective terrain and obstacle depiction);
- 8) TAWS perspective terrain and obstacle depiction (mutually exclusive with Non-TAWS perspective terrain and obstacle depiction);
- 9) Perspective traffic depiction;
- 10) Turn rate indication;
- 11) Single Cue Flight Director symbology (only shown with optional Flight Director symbology option and mutually exclusive with Dual Cue Flight Director symbology);
- 12) Dual Cue Flight Director symbology (only shown with optional Flight Director symbology option and mutually exclusive with Single Cue Flight Director symbology); or
- 13) Metric display of barometric altitude and target altitude bug setting.

In Basic Mode, the pilot may select or deselect the following items:

- 1) PFD analog AGL indicator;
- 2) Basic Mode (switches PFD back to Normal Mode);
- 3) PFD Mini traffic;
- 4) PFD Mini-map;
- 5) Turn Indicator;
- 6) FD1;
- 7) FD2; or
- 8) Meters.

5.21.1. PFD Declutter (DCLTR) Menu (Step-By-Step)



- 1) Press **MENU (R1)** then **DCLTR (R4)** to enter the Declutter menu.
- 2) Scroll **1** to select either **ANLG AGL**, **BANK SCL**, **BASIC**, **MINI MAP**, **MINI TRFC**, **SKYWAY**, **SVS TAWS**, **SVS BASIC**, **TRAFFIC**, **TURN IND**, **FD1**, **FD2**, or **METERS**, and push to enter.
- 3) If **BANK SCL** is unchecked and **1** is scrolled to **DONE**, push to enter.
- 4) The Bank Scale is removed while in level flight.

Figure 5-46: PFD Declutter (DCLTR) Menu (Step-By-Step)



- 5) Scroll **1** to **SVS TAWS** then **DONE** and push to enter.
- 6) If **SVS BASIC** mode is desired, scroll **1** to **SVS BASIC** then **DONE** and push to enter.
- 7) In the event of a TAWS Warning, the system automatically switches back to **SVS TAWS** mode if Terrain had been disabled.

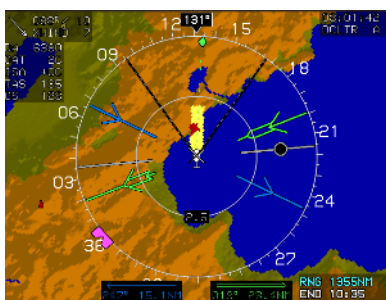


Figure 5-47: PFD Declutter (DCLTR) Menu (Step-By-Step) (Continued)

5.22. PFD Declutter (DCLTR) Menu (AW-109SP)

The Bank Scale and Flight Director options are removed from the PFD Declutter Menu.

5.23. PFD Altimeter Menu

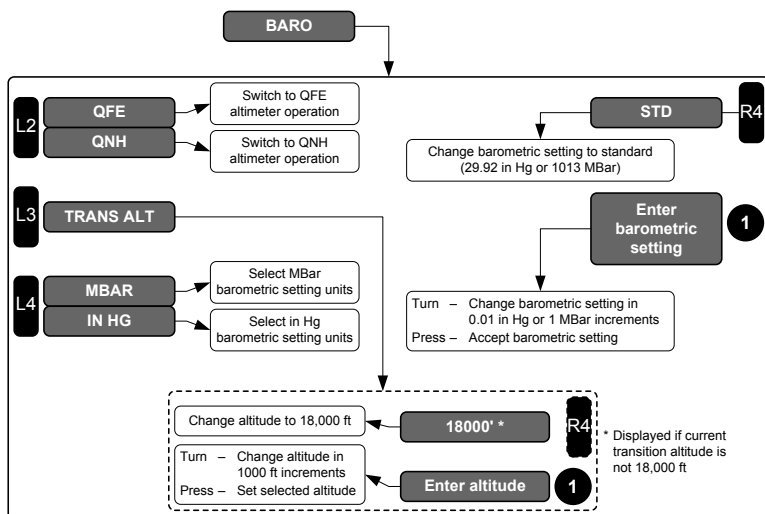



Figure 5-48: PFD Altimeter Menu

The altimeter menu is activated by pressing **BARO (R2)**. In the altimeter menu, scroll **1** to increment (clockwise) or decrement (counter-clockwise) the barometric setting and push **1** to accept the new barometric setting. In addition, the following options are available in the altimeter menu:

- 1) **QNH/QFE (L2)**: Toggles between QNH altimeter operation and QFE altimeter operation. When in QNH mode, QNE operation automatically is selected when above the transition altitude with a standard altimeter setting. The following definitions:
 - a) **QFE**: Barometric setting resulting in the altimeter displaying height above a reference elevation (e.g., airport or runway threshold).
 - b) **QNE**: Standard barometric setting (29.92 inHg or 1013 mbar [hPa]) used to display pressure altitude for flight above the transition altitude.
 - c) **QNH**: Barometric setting resulting in the altimeter displaying altitude above mean sea level at the reporting station.

- 2) **TRANS ALT (L3)**: Allows the pilot to change the transition altitude used by the system in units of 1000 feet. Transition altitude is used to generate barometric setting warnings and to determine QNE/QNH operation. If current transition altitude is not 18,000 feet, **18000'** is available to quickly set 18,000 feet as the transition altitude.
- 3) **MBAR/IN HG (L4)**: Allows the pilot to select the barometric setting units (inHg or mbar).
- 4) **STD**  **(R4)**: Sets the barometric setting to standard (29.92 inHg or 1013 mbar).

5.23.1. PFD Altimeter Menu (Step-By-Step)




- 1) Press **BARO (R2)** to enter the Altimeter menu.
- 2) Scroll  to set proper QNH and push to enter.
- 3) Crosscheck proper QNH under altitude indication.
- 4) Press BARO button again and STD button to reset QNH to 29.92 and push to enter

Figure 5-49: Altimeter Menu (Step-By-Step)

5.24. MFD Fault Display (FAULTS) Menu

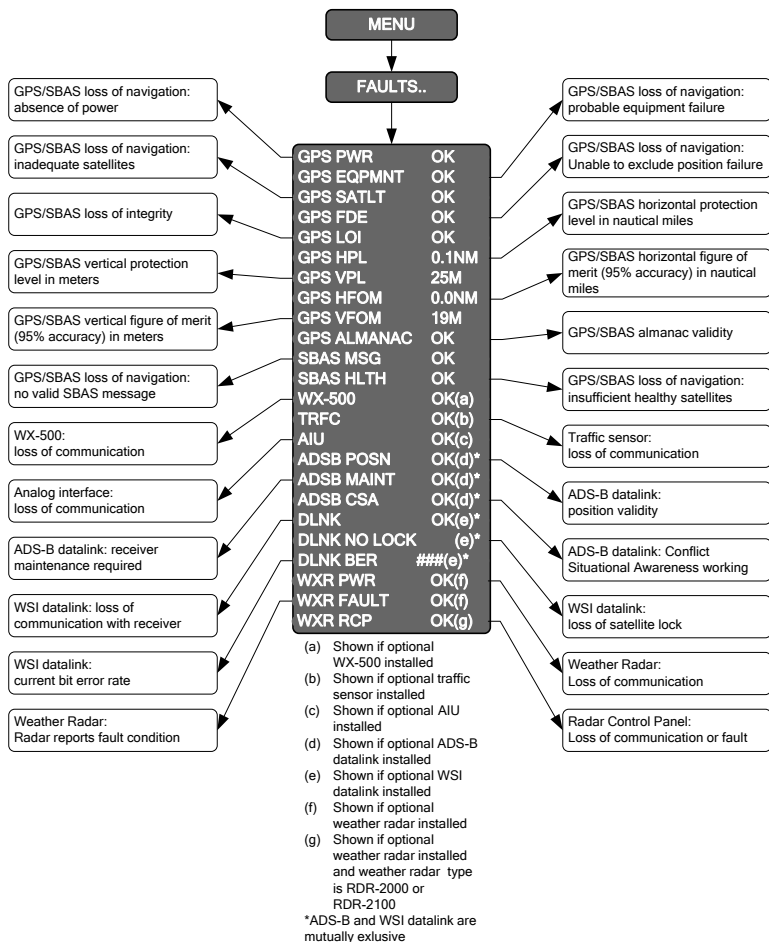


Figure 5-50: MFD Fault Display Menu

Upon selecting the MFD faults menu, the status of the following system parameters are displayed:

- 1) GPS/SBAS loss of navigation due to absence of power (GPS PWR)
- 2) GPS/SBAS loss of navigation due to probable equipment failure (GPS EQPMNT)

- 3) GPS/SBAS loss of navigation due to inadequate satellites to compute a position solution (GPS SATLT)
- 4) GPS/SBAS loss of navigation due to a position failure that cannot be excluded within the time to alert (GPS FDE)
- 5) GPS/SBAS loss of integrity and loss of navigation due to loss of integrity (GPS LOI)
- 6) Readout of the current GPS/SBAS horizontal protection level (GPS HPL) in nautical miles. This value may be used as the estimate of position uncertainty required in RNP airspace.
- 7) Readout of the current GPS/SBAS vertical protection level (GPS VPL) in meters.
- 8) Readout of the current GPS/SBAS horizontal figure of merit (GPS HFOM) in nautical miles. This value is an indication of the 95% confidence horizontal position accuracy.
- 9) Readout of the current GPS/SBAS vertical figure of merit (GPS VFOM) in meters. This value is an indication of the 95% confidence vertical position accuracy.
- 10) An indication of whether the GPS/SBAS receiver has a valid almanac in memory (GPS ALMANAC).
- 11) GPS/SBAS loss of navigation due to no valid SBAS message received for four seconds or more (SBAS MSG).
- 12) GPS/SBAS loss of navigation due to insufficient number of SBAS HEALTHY satellites (SBAS HLTH).
 - a) An Attitude or Range Fault Condition exists.
 - b) A Control Fault Condition exists.
 - c) A T/R Fault Condition exists.
- 13) If the WX-500 option is enabled, loss of communications with the WX-500 (WX-500).
- 14) If the traffic option is enabled, loss of communications with the traffic sensor (TRFC).
- 15) If the analog interface option is enabled, loss of communications with the analog interface (AIU).

- 16) If WSI datalink is enabled, the datalink item indicates either loss of communications with the datalink receiver (DLNK X), loss of satellite lock (DLNK NO LOCK), or the current bit error rate or the datalink (DLNK BER ###). WSI datalink is mutually exclusive with ADS-B datalink.
- 17) If ADS-B datalink is enabled, an indication of ADS-B position validity (ADSB POSN), an indication of whether maintenance of the ADS-B receiver is required (ADSB MAINT), and an indication of whether the Conflict Situational Awareness algorithm is working (ADSB CSA). ADS-B datalink is mutually exclusive with WSI datalink.
- 18) If weather radar is enabled, an indication of weather radar power/communication status (WXR PWR X or WXR PWR OK). Weather radar power/communication status failed (WXR PWR X) reflects any one of the following conditions are true:
 - a) Loss of weather radar communication, or
 - b) Weather radar mode is OFF .
- 19) If weather radar is enabled, an indication of weather radar fault status (WXR FAULT –, WXR FAULT X, or WXR FAULT OK). When weather radar power/communication status is failed, weather radar fault status indicates determination of weather radar faults is not possible (WXR FAULT –). Weather radar fault status failed (WXR FAULT X) reflects any one of the following conditions are true:
 - a) A Cooling Fault Condition exists.
 - b) For weather radar types ARINC 708-6 or Collins 800/840, a Display or Control Bus Fault Condition exists.
 - c) For weather radar types ARINC 708-6, Collins 800/840 or Honeywell PRIMUS, a Calibration or Air Data Fault Condition exists.
 - d) An Attitude or Range Fault Condition exists.
 - e) A Control Fault Condition exists.
 - f) A T/R Fault Condition exists.
- 20) If weather radar is enabled and the weather radar type is RDR-2000 or RDR-2100, an indication of radar control panel status

(WXR RCP X or WXR RCP OK). Radar control panel status failed (WXR RCP X) indicates either loss of communication or a failure status using the same test as invalid data SSM for output data.

5.24.1. MFD Fault Display (FAULTS) Menu (Step-By-Step)



- 1) Press **MENU (R1)** then **FAULTS (L1)** to view the faults menu.
- 2) View status of GPS and equipment parameters.

Figure 5-51: MFD Fault Display Menu (Step-By-Step)

5.25. MFD FUEL Totalizer Quantity Setting (SET FUEL) MENU

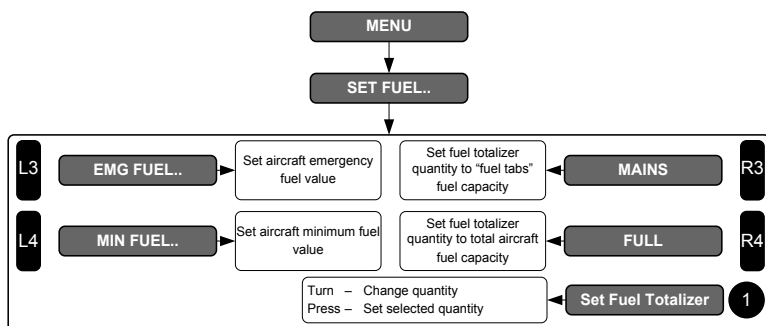



Figure 5-52: MFD Fuel Totalizer Quantity Menu

The fuel quantity setting menu allows the pilot to:

- 1) Set the fuel totalizer quantity in increments of volume units.

- 2) If either a fuel totalizer or fuel level sensing (with no unmonitored fuel) is configured in the aircraft limits, set emergency and minimum fuel bugs in increments of volume units.

Press **MAINS (R3)** to quickly set the quantity to the “fuel tabs” fuel capacity, and **FULL  (R4)** to quickly set the quantity to the total aircraft fuel capacity. Units of measure and fuel flow are shown in the quantity window when available.

5.25.1. MFD Fuel Totalizer Quantity Setting (SET FUEL) Menu (AW-109SP)

The **FUEL SET** menu is removed due to acquisition of fuel quantity from the. MFD Page (PAGE) Menu.

5.26. MFD Page

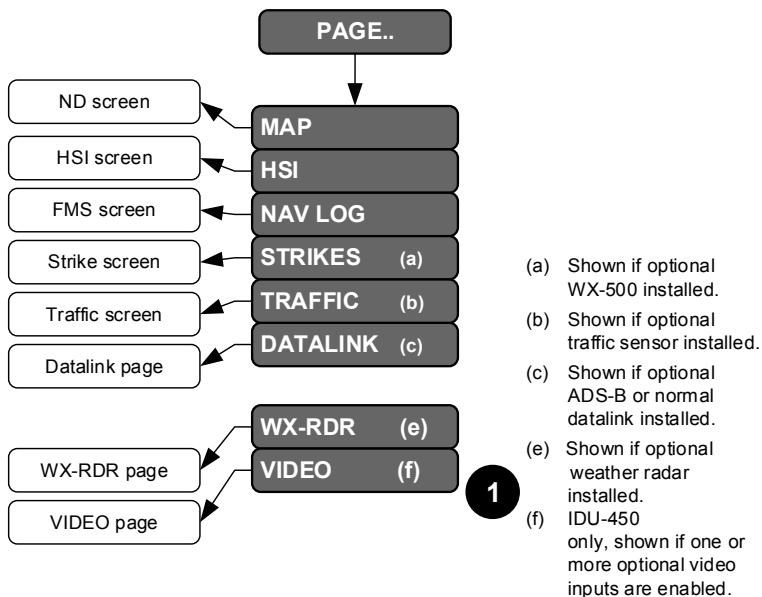
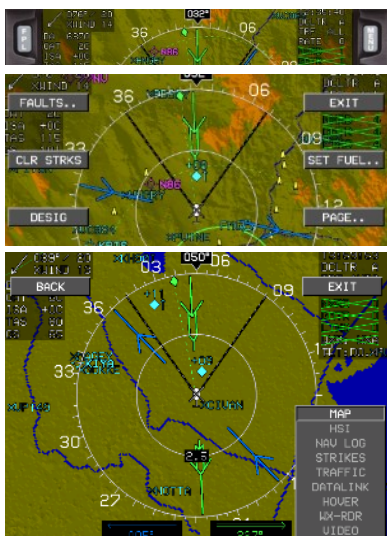


Figure 5-53: MFD Page (PAGE) Menu

The **PAGE** menu allows the pilot to select which MFD page to display. Options are:

- 1) **MAP**: Shows the ND page.
- 2) **HSI**: Shows the HSI page.
- 3) **NAV LOG**: Shows the FMS page.
- 4) **STRIKES**: Shows the Strike page.
- 5) **TRAFFIC**: Shows the Traffic page.
- 6) **DATALINK**: Shows the Datalink page.
- 7) **WX-RDR**: Shows the Weather Radar page.
- 8) **VIDEO**: Shows the Video page.

5.26.1. MFD Page (PAGE) Menu (Step-By-Step)



- 1) Press **MENU (R1)**.
- 2) Press **PAGE.. (R3)** to view page selection menu.
- 3) Push and scroll **1** to select either **MAP**, **HSI**, **NAV LOG**, **STRIKES**, **TRAFFIC**, **DATALINK**, **HOVER**, **WEATHER RADAR**, or **VIDEO** and push to enter.

Figure 5-54: MFD Page Menu (Step-By-Step)

5.26.2. MFD NAV Log Page



WAYPOINT	UNAU/OFFSET	PATH	DIST	ETE	ETA	FUEL
START	4300'	-015001'	35.2M	0+23	14:02	332
IP	4300'	0 218"	12.0M	0+14	14:02	332
KLAFSS	1906'	0 218"	5.9M	0+02	13:40	321
RH22L	027'	216° 500'	0.0M	0+00	13:42	316
AL	800'	0 253"	0.2M	0+00	13:42	316
AL	1333'	0 253"	0.2M	0+00	13:48	315
MICRO	2100'	0 264"	16.2M	0+10	14:08	331
MICRO	2100'	0 264"	5.8M	0+06	14:16	324
(KLFT)	-----	-----	-----	-----	-----	-----

WAYPOINT	UNAU/OFFSET	PATH	DIST	ETE	ETA	FUEL
START	4400'	-015001'	35.2M	0+23	14:12	332
IP	4400'	0 218"	12.0M	0+10	14:12	332
KLAFSS	1906'	0 218"	5.9M	0+02	13:57	341
RH22L	027'	216° 500'	0.0M	0+00	14:00	323
AL	800'	0 253"	0.2M	0+00	14:00	323
AL	1333'	0 253"	0.2M	0+00	14:00	323
MICRO	2100'	0 264"	16.2M	0+10	14:11	327
MICRO	2100'	0 264"	5.8M	0+06	14:16	330
(KLFT)	-----	-----	-----	-----	-----	-----

- 1) Press **MENU (R1)** then **PAGE (R3)** and scroll **1** to **NAV LOG** and push to enter.
- 2) **NAV LOG** page cannot be formatted or used to edit the active flight plan.
- 3) **NAV LOG** page shown for AW-109SP aircraft.

Figure 5-55: NAV LOG Page Menu (Step-By-Step)

5.26.3. MFD ND Page Format (FORMAT) Menu

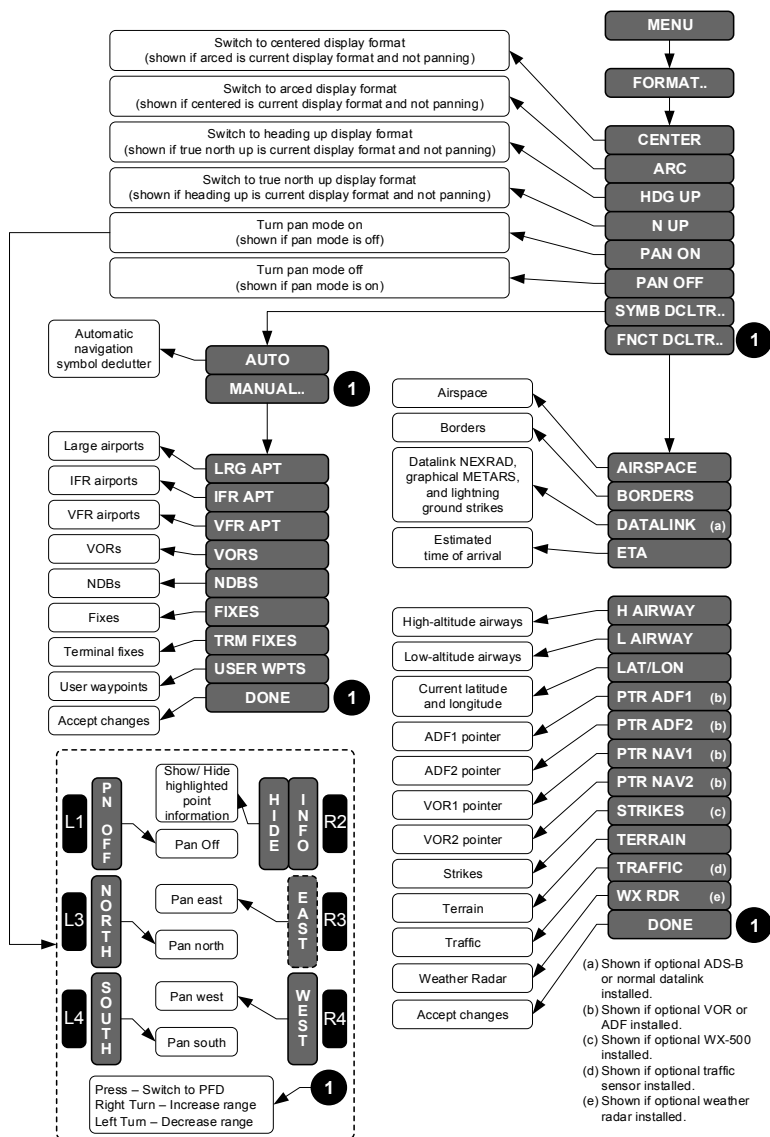


Figure 5-56: MFD ND Page Format Menu

Upon selecting the MFD format menu when in the ND page, an option list appears with the following:

- 1) **CENTER/ARC:** Toggles between a centered and arced ND display format (if not panning).
- 2) **HDG UP/N UP:** Toggles between a heading up and a North up ND display format (if not panning).
- 3) **PAN ON/PAN OFF:** Toggles ND page pan mode.
- 4) **SYMB DCLTR:** Activates an option list for the pilot to choose either automatic navigation symbol declutter or manual navigation symbol declutter. If the pilot chooses manual navigation symbol declutter, a further option list appears to allow the pilot to individually select:



Figure 5-57: MFD Symbol Declutter

Turning on VFR airports also turns on large and IFR airports. Turning on IFR airports also turns on large airports. Turning off large airports also turns off IFR and VFR airports. Turning off IFR airports also turns off VFR airports.

- 5) **FNCT DCLTR:** Activates an option list for the pilot to individually toggle display of:
 - a) airspace;

- b) borders;
- c) datalinked NEXRAD, graphical METARs and lightning ground strikes (if datalink or ADS-B option is enabled);
- d) estimated time of arrival (ETA);
- e) high-altitude airways;
- f) low-altitude airways;
- g) current latitude and longitude display of ADF #1 pointer (if ADF symbology is enabled);
- h) ADF #2 pointer (if dual ADF symbology is enabled);
- i) VOR1 pointer (if VOR symbology is enabled);
- j) VOR2 pointer (if dual VOR symbology is enabled);
- k) Strikes (if WX-500 option is enabled);
- l) Terrain;
- m) Traffic (if traffic option is enabled); and
- n) Weather radar (if weather radar option is enabled).

5.26.4. MFD ND Page Format (FORMAT) Menu (Step-By-Step)



- 1) Press **MENU (R1)** and **FORMAT.. (R4)**.



- 2) Scroll **1** to **FNCT DCLTR..** and push to enter.



- 3) Scroll **1** to **LAT/LON**, scroll to **DONE**, and push to enter.



- 4) Or if AW109SP, scroll **1** to **SWS GRD**, push **1** to check, scroll to **DONE**, and push to enter.
- 5) The AW-109SP option for **SWS GRD** results in the PFD showing **SWISS GRID**.

Figure 5-58: MFD ND Page Format (Step-By-Step)

CAUTION:

The Swiss Grid should not be used outside of Switzerland.

5.26.5. MFD HSI Page



- 1) Press **MENU (R1)** then **PAGE (R3)** and scroll **1** to **HSI** and push to enter.



- 2) HSI page displayed for rotorcraft other than AW-109SP.



- 3) HSI displayed for the AW-109SP.

Figure 5-59: HSI Page Menu (Step-By-Step)

5.26.6. MFD HSI Pointer (PTRS) Menu

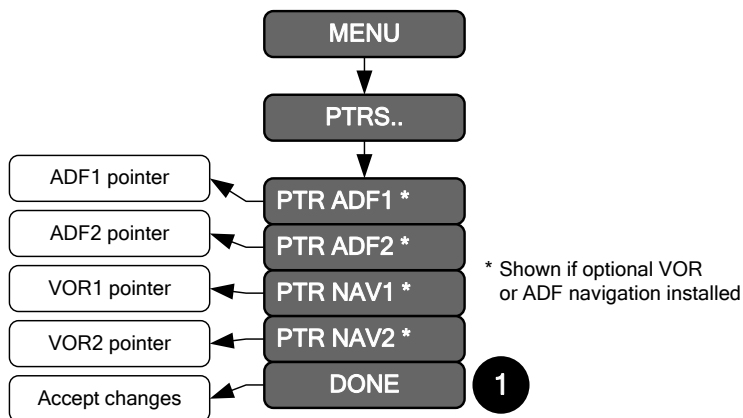


Figure 5-60: MFD HSI Pointer (PTRS) Menu

Upon selecting the HSI pointers menu when in the HSI page, an option list appears to allow the pilot to individually select display of:

- 1) ADF1 pointer (if ADF symbology is enabled);
- 2) ADF2 pointer (if dual ADF symbology is enabled);
- 3) VOR1 pointer (if VOR symbology is enabled); and
- 4) VOR2 pointer (if dual VOR symbology is enabled).

5.26.7. MFD Strike Format (FORMAT) Menu

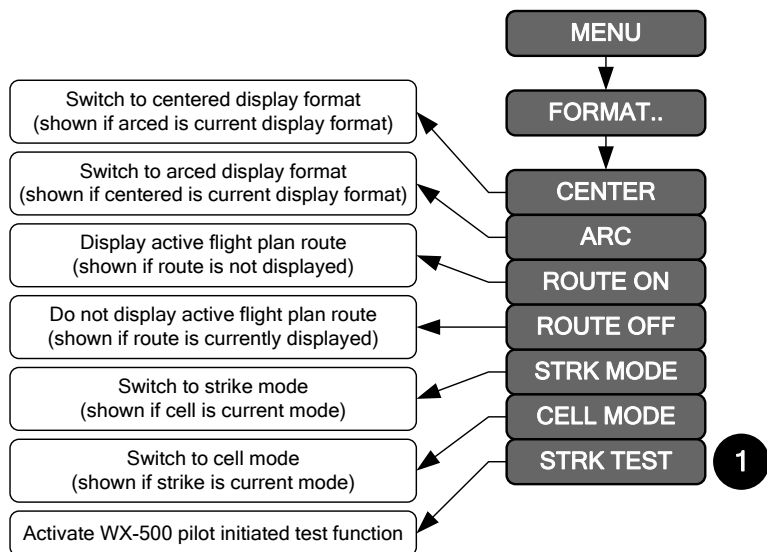


Figure 5-61: MFD Strike Format Menu

Upon selecting the MFD format menu when in the Strike page, the following option list appears with the following:

- 1) **CENTER/ARC**: Toggles between a centered and arced Strike page display format.
- 2) **ROUTE ON/ROUTE OFF**: Toggles showing the active flight plan route on the Strike page.
- 3) **STRK MODE/CELL MODE**: Toggles between strike mode strikes and cell mode strikes on the Strike page.
- 4) **STRK TEST**: Activates the WX-500 pilot initiated test function.

5.26.8. MFD Traffic Format (FORMAT) Menu

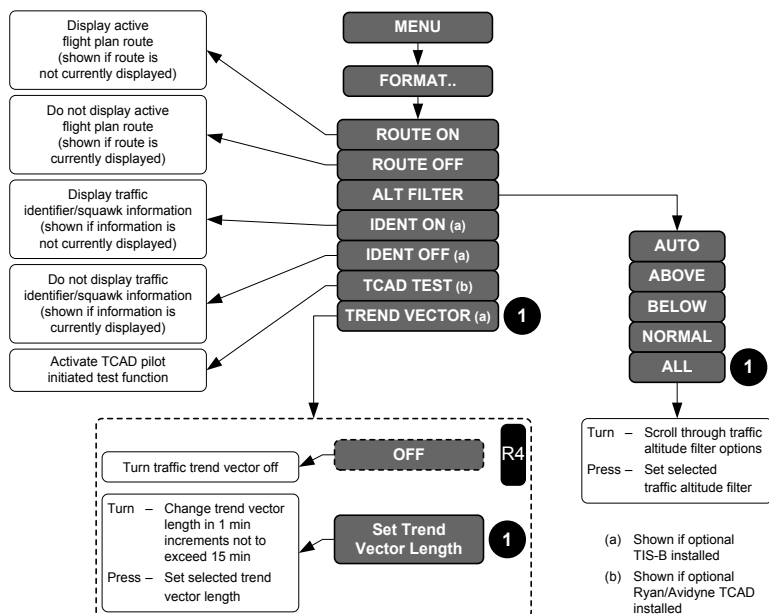



Figure 5-62: MFD Traffic Format Menu

Upon selecting the MFD format menu when in the Traffic page, an option list appears with the following:

- 1) **ROUTE ON/ROUTE OFF:** Toggles showing the active flight plan route on the Traffic page.
- 2) **IDENT OFF/IDENT ON:** When the TCAS flag is TIS-B, toggles showing traffic identifier/squawk information.
- 3) **ALT FILTER:** Sets the traffic altitude filter to either **AUTO**, **ABOVE**, **BELOW**, **NORMAL**, or **ALL**.
- 4) **TCAD TEST:** When the TCAS flag is Ryan/Avidyne TCAD, activates the TCAD pilot initiated test function.
- 5) **TREND VECTOR:** When the TCAS flag is TIS-B, use to select

the traffic trend vector length in minutes. **OFF**  **(R4)** appears at this level for the pilot to quickly turn off the traffic trend vector.

5.26.9. MFD Datalink Format (FORMAT) Menu

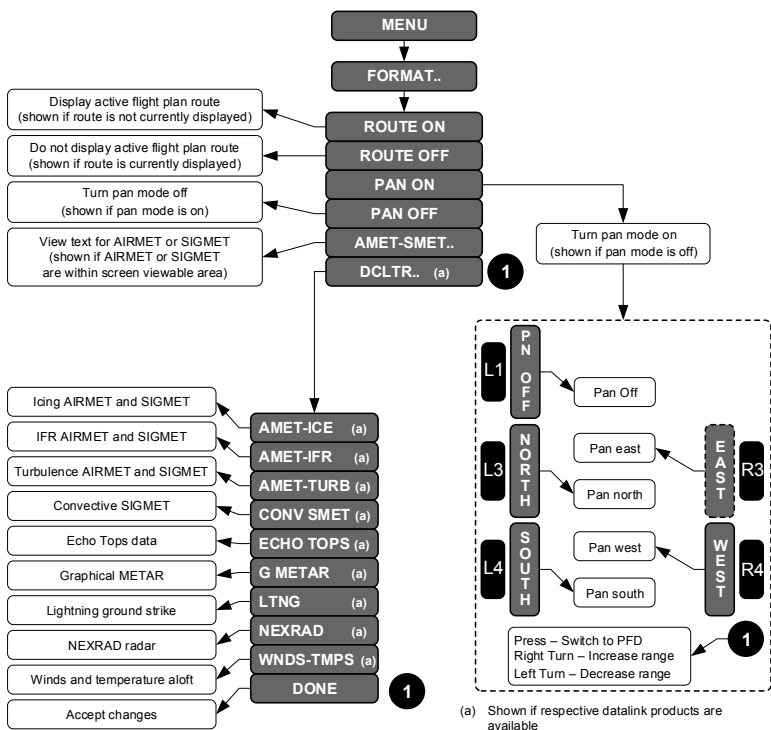


Figure 5-63: MFD Datalink Format Menu

Upon selecting the MFD format menu when in the Datalink page, an option list appears with the following:

- 1) **ROUTE ON/ROUTE OFF:** Toggles showing the active flight plan route on the Datalink page.
- 2) **PAN ON/PAN OFF:** Toggles Datalink page Pan mode.
- 3) **AMET-SMET:** Only available when an AIRMET or SIGMET is within the Datalink page viewable area. Allows the pilot to view the text for the displayed AIRMETs and SIGMETs. While viewing the text for a particular AIRMET or SIGMET, the border associated with the AIRMET or SIGMET flashes on the page.

- 4) **DCLTR**: Only available when datalink weather products are available for display. Allows the pilot to select individual datalink weather products for display. Only datalink weather products available for display appear in the selection box.

5.26.10. MFD Video Input Format (FORMAT) Menu

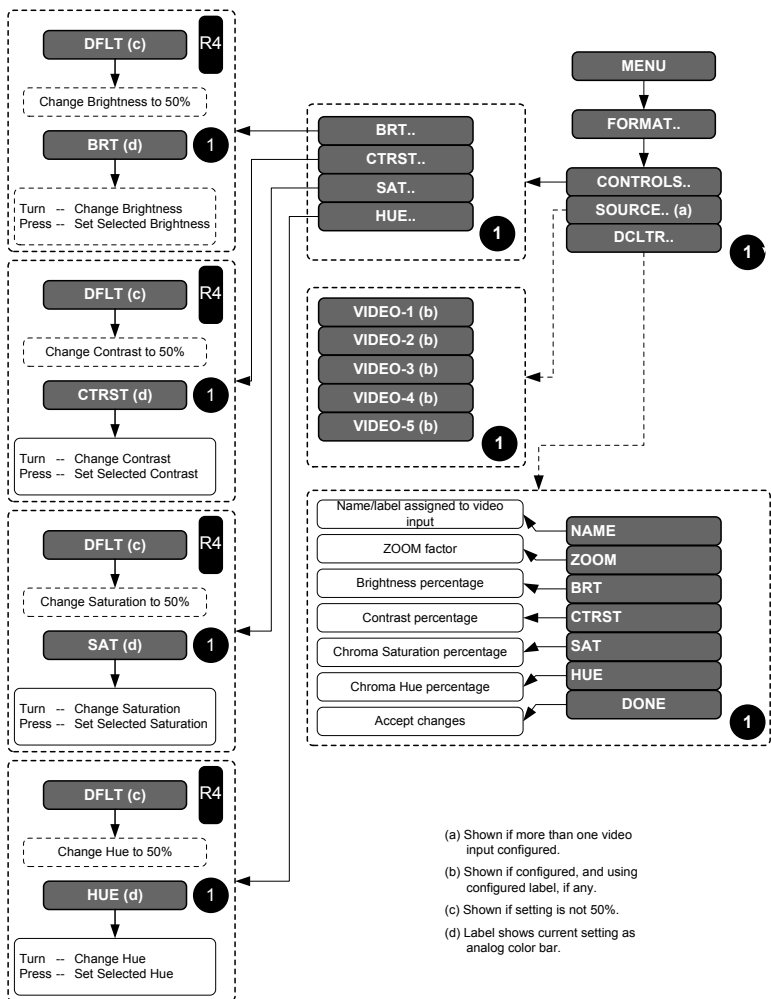


Figure 5-64: MFD Video Input Format Menu

Upon selecting the MFD format menu when in the Video Input page, an option list appears with the following.

Table 5-5: Video Input Controls		
Controls Settings	Definition	Notes
BRT	Adjust the brightness setting for the current Video input.	When not at the nominal default (50%) value, DFLT (R4) appears for resetting brightness to nominal default value with single press.
CTRST	Adjust the contrast setting for current video input	When not at the nominal default (50%) value, DFLT (R4) appears for resetting contrast to nominal default value with single press.
SAT	Adjust the chroma saturation (color intensity) setting for current video input.	When not at the nominal default (50%) value, DFLT (R4) appears for resetting to nominal default value with single press.
HUE	Adjust the chroma hue (red-green balance) settings for current video input.	When not at the nominal default (50%) value, DFLT (R4) appears for resetting to nominal default value with single press.
SOURCE	Selection of optional video source.	Only available if more than one video input is enabled. This option allows for selected video input to be displayed.
DCLTR	Activates an option list allowing individual selection of which video input status settings are displayed.	<ol style="list-style-type: none"> 1) NAME: (Video input label) 2) ZOOM: (Current amount of image expansion) 3) BRT: (Current brightness setting) 4) CTRST: (Current contrast setting) 5) SAT: (Current chroma saturation setting) 6) HUE: (Current chroma hue setting)

Section 6 Quick Start Tutorial

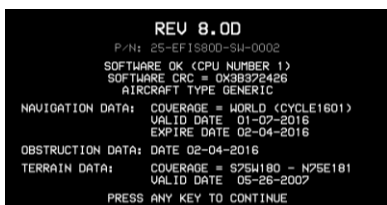
Quick Reference Guide (DOC 64-000100-080D)



Begin by reading the EFIS Rotorcraft Flight Manual Supplement...



... or the AW-109SP Rotorcraft Flight Manual.



Power up the EFIS system. The system performs a built-in test routine. If all tests pass, the system displays a screen identifying the database coverage. Press any button to acknowledge, and the system begins a two-minute countdown while awaiting sensor initialization. (For the purposes of flight planning, etc, press any button to override this countdown.)



1

The encoder is numbered #1 from the right side (1).



Press **BARO (R2)** and scroll **⬇️** to desired QNH and push to enter.



Press **⏪ (R4)** for Direct To menu. If in the air, the nearest airport appears. Scroll **⬇️** to the desired alpha or numerical character then push to confirm and advance to the next position. Push to enter, until all five spaces have been either entered or viewed.

Other than
AW-109SP



A magnetic waypoint bearing appears on the heading scale as shown on other than AW-109SP in magenta color and the AW-109SP in cyan color.



AW-109SP



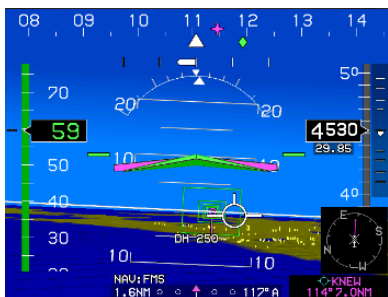


A direct route to the active waypoint is activated and appears as magenta tethered balloon on the PFD as shown for rotorcraft other than the AW-109SP.



On the AW-109SP PFD, the active waypoint appears as a cyan colored tethered balloon.

The active waypoint information, including waypoint type and identifier, elevation or crossing altitude, and bearing and distance are displayed below the Analog AGL indicator or Mini Map as configured.



Indicated airspeed is on the left, altitude is on the right, and heading is across the top. A FMS/VLOC CDI is located on the bottom. The VSI appears on the right side of the altitude tape on rotorcraft other than AW-109SP.



(AW-109SP)



On the MFD, press **MENU (R1)** to view soft menu selections for easy access with press of appropriate IDU button on rotorcraft other than AW-109SP.



On the MFD, press **MENU (R1)** to view soft menu selections for easy access with press of appropriate IDU button on AW-109SP.

Flight Plans (Stored Routes)

Activate a Stored Flight Plan on PFD

- 1) Press **FPL (L1)**.
- 2) Scroll **1** through stored flight plans.
- 3) Push **1** to activate desired flight plan.

Activate Flight Plan on MFD

- 1) Press **FPL (L1)**.
- 2) Push **1** to display list of stored flight plans.
- 3) Select desired flight plan to activate as described above.
- 4) Push **1** to activate desired flight plan.

Create Flight Plan on MFD

- 1) Press **FPL (L1)**.
- 2) Scroll **1** to **CREATE-EDIT..** and push to enter.
- 3) Select **CREATE FLIGHT PLAN** and push to enter.
- 4) Press **ADD (R2)** to create first waypoint with **1** by entering waypoints from beginning to end.
- 5) Press **SAVE (R4)** to save flight plan.
- 6) Press **BACK (L1)** to return to function select page or;
- 7) Press **EXIT (R1)** to exit Flight Planner.

Waypoints

Edit a User Waypoint (MFD only)

- 1) Press **FPL (L1)**.
- 2) Scroll **1** to highlight **CREATE-EDIT..** and push to enter.
- 3) Scroll **1** to **EDIT USER WPT** and push to enter.
- 4) Scroll **1** to highlight waypoint to be edited and push to enter.
- 5) Edit waypoint and press **SAVE (R4)** to save new USER WPT data.
- 6) Press **EXIT (R1)** to exit flight planner.

Create a User Waypoint on PFD or MFD

- 1) Press the **MENU (R1)**.
- 2) Press **DESIG (L3)**.

Add Waypoint to an Active Route on PFD or MFD

- 1) Press **ACTV (L2)**.
- 2) Scroll **1** to location on waypoint list where added waypoint is to be inserted above.
- 3) Press **INSERT (R2)**.
- 4) Press **NRST APT.. (L2)**, **NRST VOR.. (L3)**, **NRST NDB.. (L4)**, **NRST FIX.. (R2)**, or **NRST USR.. (R3)** then scroll **1** to make selection and push to enter.
- 5) Use **1** to enter waypoint identifier and push to enter.

Delete Waypoint from an Active Route

- 1) Press **ACTV (L2)**.
- 2) Scroll **1** to highlight waypoint to delete (if this is part of a published procedure, press **DELETE (R3)** to prompt **CONFIRM DEL PROC**).
- 3) Push **1** to **CONFIRM DEL PROC** and push to enter.

Omnibearing Selector Function

Automatic OBS (FMS OBS only)

- 1) Press **OBS (L4)**.
- 2) Push **1 OBS:AUTO** to enter.

Manual OBS

- 1) Press **OBS (L4)**.
- 2) Select desired HSI source, press **NAV VLOC1 (L3)** or **NAV VLOC2 (L4)**.
- 3) If HSI source is NAV FMS, press **OBS MANUAL (R4)** then scroll **1** to desired OBS value and push to enter or **OBS SYNC (R3)** and push to enter.
- 4) If HSI source is **NAV VLOC1 (L3)** or **NAV VLOC2 (L4)**, scroll **1** to desired course (OBS:XXX° (XXX°)) and push to enter.

Approaches/Track

Select a VFR Approach

(The active flight plan must contain an eligible airport [or USR WPT with runway bearing] for VFR approach creation.)

- 1) Press **ACTV (L2)**.
- 2) Scroll **1** to highlight the desired airport or user waypoint, push to enter.
- 3) Scroll **1** to highlight **VFR APPR..** and push to enter.
- 4) Scroll **1** to select desired runway (n/a for USR WPT) and push to enter.

Change Runway during VFR Approach

- 1) Press **ACTV (L2)**.
- 2) Scroll **1** to highlight the following and push to enter:
 - a) Destination airport
 - b) **VFR APPR..**
 - c) Desired runway, push to enter.

(This deletes the previous VFR approach and creates a new VFR approach to the selected runway.)

Change Runway on IFR Approach

- 1) Press **ACTV (L2)**.
- 2) Scroll **1** to destination airport and push to enter.
- 3) Select **IFR APPR.:**, scroll **1** to desired approach, and push to enter.
- 4) Select **TRANS.:**, scroll **1** to desired transition, and push to enter.
- 5) Select **RW.:**, scroll **1** to desired runway, and push to enter.

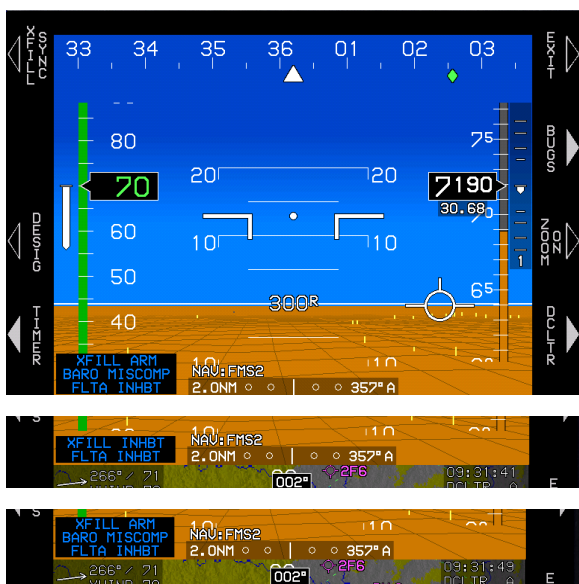
(This deletes the previous IFR approach and creates a new IFR approach to the selected runway.)

XFILL Sync Operation

XFILL Sync Operation

(Crossfill is the normal default mode of operation.)

- 1) During crossfill inhibited operation, **XFILL INHBT** appears on the PFD in the lower left corner.
- 2) When the pilot and co-pilot systems are not synchronized, **XFILL ARM** appears on the PFD in the lower left corner.
- 3) When the pilot and co-pilot systems are not synchronized, press **MENU (R1)** then **XFILL SYNC (L1)** to synchronize the pilot and co-pilot active flight plan parameters from the system where the button press occurred.



Section 7 IFR Procedures

Table of Contents

SECTION 7	IFR PROCEDURES	7-1
7.1.	IFR PROCEDURES.....	7-6
7.2.	OVERVIEW OF PROCEDURES AND INSTRUMENT APPROACHES	7-6
7.2.1.	<i>Vertical Deviation Indicator Linear Limits</i>	7-8
7.2.2.	<i>Highway in the Sky (Skyway)</i>	7-8
7.2.3.	<i>Waypoint Sequencing</i>	7-13
7.2.4.	<i>Fly-Over Waypoints</i>	7-14
7.2.5.	<i>Fly-By Waypoints</i>	7-16
7.2.6.	<i>Direct-To</i>	7-21
7.3.	MAGNETIC COURSE	7-21
7.3.1.	<i>AHRS Modes for Heading Source</i>	7-22
7.3.2.	<i>GPS Altitude</i>	7-22
7.3.3.	<i>Dead Reckoning</i>	7-22
7.3.4.	<i>Geodesic Path Computation Accuracy</i>	7-23
7.3.5.	<i>Parallel Offsets</i>	7-23
7.4.	DEFAULT GPS/SBAS NAVIGATION MODES	7-25
7.5.	GPS/SBAS CDI SCALE	7-28
7.6.	APPROACH TYPE SELECTION.....	7-29
7.6.1.	<i>Approach Path Definition</i>	7-31
7.7.	VTF IFR APPROACH	7-31
7.8.	VTF VFR APPROACH.....	7-32
7.9.	MISSED APPROACH AND DEPARTURE PATH DEFINITION	7-32
7.10.	LOSS OF NAVIGATION MONITORING.....	7-33
7.11.	DISCONTINUITIES	7-34

7.12.	SELECTION OF AN INSTRUMENT PROCEDURE	7-34
7.12.1.	<i>Standard Instrument Departure (SID)</i>	7-36
7.12.2.	<i>Standard Terminal Arrival Route (STAR)</i>	7-38
7.12.3.	<i>ILS Instrument Approach</i>	7-40
7.12.4.	<i>LOC Back Course Instrument Approach</i>	7-45
7.12.5.	<i>RNAV (GPS) Instrument Approach to LPV Minima</i>	7-49
7.13.	COPTER RNAV (GNSS) APPROACH	7-52
7.13.1.	<i>NRST ILS Instrument Approach</i>	7-57
7.13.2.	<i>VOR/DME Instrument Approach</i>	7-62
7.13.3.	<i>Copter RNAV (GPS) Instrument Approach</i>	7-66

List of Figures and Tables

FIGURE 7-1: VERTICAL DEVIATION INDICATOR LINEAR DEVIATION	7-8
TABLE 7-1: HIGHWAY IN THE SKY CONFIGURATION.....	7-9
FIGURE 7-2: HIGHWAY IN THE SKY (AIRCRAFT REFERENCED)	7-10
FIGURE 7-3: HIGHWAY IN THE SKY (GEO-REFERENCED BACKWARD).....	7-11
.....	
FIGURE 7-4: HIGHWAY IN THE SKY (GEO-REFERENCED FORWARD)	7-11
TABLE 7-2: FINAL SEGMENT OF IFR APPROACH, DESCENT ANGLE AND VNAV WAYPOINT.....	7-12
FIGURE 7-5: HIGHWAY IN THE SKY FINAL APPROACH SEGMENTS	7-13
FIGURE 7-6: FLY-OVER WAYPOINTS.....	7-14
TABLE 7-3: RNAV PATH TERMINATOR LEG TYPE.....	7-15
FIGURE 7-7: FLY-BY WAYPOINTS	7-16
TABLE 7-4: LEG SEGMENTS FOR PATHS CONSTRUCTED BY THE IDU	7-17
.....	
FIGURE 7-8: PARALLEL OFFSET ENTRY WAYPOINT (AW-109SP) ...	7-24
TABLE 7-5: DEFAULT GPS/SBAS NAVIGATION MODES	7-25
TABLE 7-6: DEFAULT NAVIGATION MODES BASED UPON REGION OF OPERATION.....	7-26
TABLE 7-7: SUMMARY OF CHANGES IN CROSS-TRACK FSD	7-28
FIGURE 7-9: GPS MODE (LNAV APPR)	7-31
FIGURE 7-10: NAVIGATING TO FAF ON VTF VFR APPROACH	7-32
FIGURE 7-11: MISSED APPROACH AND DEPARTURE PATH.....	7-33
FIGURE 7-12: STANDARD INSTRUMENT DEPARTURE (SID)	7-36
FIGURE 7-13: STANDARD INSTRUMENT DEPARTURE (SID) (STEP-BY- STEP)	7-37
FIGURE 7-14: STANDARD TERMINAL ARRIVAL ROUTE (STAR).....	7-38
FIGURE 7-15: STAR PROCEDURE (STEP-BY-STEP)	7-39
FIGURE 7-16: STAR PROCEDURE (STEP-BY-STEP) (CONTINUED)..	7-40
FIGURE 7-17: ILS RWY 10 (MSY).....	7-41
FIGURE 7-18: ILS RWY 10 (KMSY) (STEP-BY-STEP)	7-42
FIGURE 7-19: ILS RWY 10 (KMSY) (STEP-BY-STEP) (CONTINUED).....	7-43
.....	
FIGURE 7-20: ILS RWY 10 (KMSY) (STEP-BY-STEP) (CONTINUED).....	7-44
.....	
FIGURE 7-21: LOC BACK COURSE APPROACH	7-45
FIGURE 7-22: LOC BACK COURSE APPROACH (STEP-BY-STEP)	7-46
FIGURE 7-23: LOC BACK COURSE APPROACH (STEP-BY-STEP) (CONTINUED)	7-47
FIGURE 7-24: LOC BACK COURSE APPROACH (STEP-BY-STEP) (CONTINUED)	7-48
FIGURE 7-25: RNAV (GPS) INSTRUMENT APPROACH TO LPV MINIMA ..	7-49
.....	

FIGURE 7-26: RNAV (GPS) INSTRUMENT APPROACH TO LPV MINIMA (STEP-BY-STEP).....	7-50
FIGURE 7-27: RNAV (GPS) INSTRUMENT APPROACH TO LPV MINIMA (STEP-BY-STEP) (CONTINUED).....	7-51
FIGURE 7-28: COPTER RNAV (GNSS) APPROACH	7-52
FIGURE 7-29: COPTER RNAV (GNSS) APPROACH (STEP-BY-STEP).....	7-53
FIGURE 7-30: COPTER RNAV (GNSS) APPROACH (STEP-BY-STEP) (CONTINUED).....	7-54
FIGURE 7-31: COPTER RNAV (GNSS) APPROACH (STEP-BY-STEP) (CONTINUED).....	7-55
FIGURE 7-32: NRST ILS INSTRUMENT APPROACH	7-57
FIGURE 7-33: NEAREST ILS INSTRUMENT APPROACH (STEP-BY-STEP)	7-58
FIGURE 7-34: NEAREST ILS INSTRUMENT APPROACH (STEP-BY-STEP) (CONTINUED).....	7-59
FIGURE 7-35: NEAREST ILS INSTRUMENT APPROACH (STEP-BY-STEP) (CONTINUED).....	7-60
FIGURE 7-36: NEAREST ILS INSTRUMENT APPROACH (STEP-BY-STEP) (CONTINUED).....	7-61
FIGURE 7-37: VOR/DME INSTRUMENT APPROACH	7-62
FIGURE 7-38: VOR/DME INSTRUMENT APPROACH (STEP-BY-STEP).....	7-63
FIGURE 7-39: VOR/DME INSTRUMENT APPROACH (STEP-BY-STEP) (CONTINUED).....	7-64
FIGURE 7-40: VOR/DME INSTRUMENT APPROACH (STEP-BY-STEP) (CONTINUED).....	7-65
FIGURE 7-41: COPTER RNAV (GPS) APPROACH.....	7-66
FIGURE 7-42: COPTER RNAV (GPS) APPROACH (STEP-BY-STEP).....	7-67
FIGURE 7-43: COPTER RNAV (GPS) APPROACH (STEP-BY-STEP) (CONTINUED).....	7-68
FIGURE 7-44: COPTER RNAV (GPS) APPROACH (STEP-BY-STEP) (CONTINUED).....	7-69
FIGURE 7-45: COPTER RNAV (GPS) APPROACH (STEP-BY-STEP) (CONTINUED).....	7-70

7.1. IFR Procedures

Pilots operating in a radar environment are expected to associate departure headings or an RNAV departure advisory with vectors or the flight path to their planned route or flight. Use of both types of departure procedures, Obstacle Departure Procedures (ODP) are printed either textually or graphically, and Standard Instrument Departure procedures (SIDs) are always printed graphically. All DPs, either textual or graphic, may be designed using either conventional or RNAV criteria. RNAV procedures have RNAV printed in the title.

ODPs are not found in the navigation database, and therefore the climb angle found in the PFD BUGS menu should be set to comply with the steeper than normal climb gradient during the departure until established on the enroute structure. ODPs are recommended for obstruction clearance and may be flown without ATC clearance, unless an alternate departure procedure (SID or radar vector) has been specifically assigned by ATC.

Approach minima are never coded in NavData. On some approaches, the altitude coded at the MAP for a non-precision approach coincides with an MDA (normally where the final approach course does not align with the runway), but more often the coded altitude is some height above the threshold.

7.2. Overview of Procedures and Instrument Approaches

This Genesys Aerosystems EFIS provides three-dimensional GPS Precision and Non-precision instrument approach guidance using a system integral TSO C146c BETA 3 GPS receiver with GPS and augmented GPS with SBAS (Satellite Based Augmentation System) commonly referred to as WAAS (Wide Area Augmentation System). In order to support full integration of RNAV procedures into the National Airspace System (NAS), a new charting format for Instrument Approach Procedures (IAPs) has been designed to avoid confusion and duplication of Instrument Approach Charts.

Use of this GPS receiver provides a level of certified service supporting RNAV (GPS) approaches to LNAV, LP, LNAV/VNAV, and LPV lines of minima within system coverage. Some locations close to the edge of the coverage may have lower availability of vertical guidance.

The new procedures, called Approach with Vertical Guidance (APV), are defined in ICAO Annex 6 and include approaches such as the LNAV/VNAV procedures presently being flown with barometric vertical navigation (BARO-VNAV). These approaches provide vertical guidance but do not meet the more stringent standards of a precision approach. With the BETA 3 GPS receiver and updatable navigation database in this system, these approaches may be flown using an electronic glidepath, which eliminates the errors introduced by using barometric altimetry.

In addition to the LNAV/VNAV procedures, the APV approach has been implemented to take advantage of the high accuracy guidance and increased integrity provided by GBS/SBAS. This SBAS (TEROS/ICAO) generated angular guidance allows the use of the same TERPS approach criteria used for ILS approaches. The resulting approach procedure minima, titled LPV (Localizer Performance with Vertical guidance), may have a decision altitude as low as 200 feet height above touchdown (EASA OPS LPV 250 ft.) with visibility minimums as low as ½ mile (providing the terrain and airport infrastructure and regulations support the lowest minima criteria).

Another new non-precision GPS/SBAS Approach has been certified as an LP (Localizer Performance) approach where terrain or obstructions prohibit the certification of the LPV vertically guided approach. This new approach takes advantage of the angular lateral guidance and smaller position errors (provided by GPS/SBAS) to provide a lateral only procedure similar to an ILS Localizer. LP procedures may provide lower minima than a LNAV procedure due to the narrower obstacle clearance surface. In the LP approach, vertical guidance is for information only and is based on SBAS or BARO information.

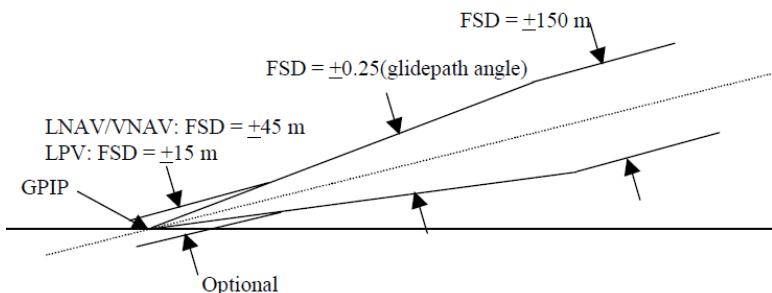
The Genesys Aerosystems EFIS guides the pilot through every step of the approach procedure with Highway in the Sky 3-D symbology. The system defines a desired flight path based upon the active flight plan. The current position of the aircraft is determined relative to the desired path in order to determine lateral deviation for display on the GPS/SBAS CDI and VDI. The IDU auto-sequences from one waypoint to the next in accordance with the flight plan along the flight path with the following exceptions as described:

- 1) The pilot has selected a manual GPS/SBAS OBS (**SUSPEND** shown).

- 2) The active waypoint is the missed approach waypoint, and the missed approach procedure has not been armed (**ARM**) or initiated (**MISS**) (**SUSPEND** shown).
- 3) The aircraft is in a published or manually created holding pattern, and the pilot has not chosen to continue (**CONT**) out of the holding pattern (**SUSPEND** shown).
- 4) The active waypoint is the last waypoint of the active flight plan (no flag shown).

The linear vertical scale limits of the VDI for LNAV/VNAV and LPV approaches are shown in Figure 7-1.

7.2.1. Vertical Deviation Indicator Linear Limits



Note: Offset conical vertical deviation reference surface and hyperboloid surface are not depicted.

Figure 7-1: Vertical Deviation Indicator Linear Deviation

7.2.2. Highway in the Sky (Skyway)

When not decluttered, the PFD displays the active navigation route or manual OBS course in a three-dimensional manner using a series of skyway boxes, which are a series of perspective objects overlying the flight plan route at a desired altitude providing lateral and vertical guidance. The skyway boxes conform to the VNAV requirements of GPS/SBAS receiver requirements (TSO-C-146C). The top and bottom sides of the boxes are parallel to the horizon on straight leg segments and dynamically tilt with respect to the horizon on turning leg segments based upon leg segment turn radius and groundspeed. When the active route is in view, up to five boxes are shown with the dimensions being a constant 400 feet wide (±200

feet from the desired lateral path) by 320 feet tall (± 160 feet from the desired vertical path) spaced horizontally 2000 feet. The skyway boxes are drawn using the hidden surface removal techniques of the terrain and obstruction rendering so a skyway box behind terrain appears to be so. The skyway boxes disappear in Basic Mode and Unusual Attitude Mode. In reversionary mode 1 (GPS failure), the skyway boxes disappear after one minute to indicate degraded navigation performance.

Table 7-1: Highway in the Sky Configuration

Type HITS Lines	Fully Integrated Autopilot	Partially Integrated Analog Autopilot (Through use of HDG Mode and or NAV/APR mode discrete inputs)	Un-Integrated Autopilot Or No Autopilot
Dashed	Not coupled to Skyway	Not coupled to Skyway	
Solid	Coupled to Skyway	Coupled to Skyway. Either autopilot is in HDG mode with LNAV heading/roll-steering sub-mode engaged or autopilot is in NAV/APR mode with the FMS, FMS1, or FMS2 as the selected navigation source.	Always Solid

Skyway box altitude is controlled by VNAV altitude, aircraft altitude, aircraft climb performance, and climb/descent angle setting. If no VNAV altitude is set, the skyway boxes describe the desired lateral flight path of the aircraft at the aircraft's current altitude.

With a VNAV altitude set, the boxes provide both lateral and vertical guidance. Climb and descent angle settings are controlled individually with a resolution of 0.1° . VNAV is guided by VNAV waypoints determined by VNAV altitude and VNAV offset from flight plan waypoints. There are two sources for VNAV altitudes, the navigation database and manual input through the ACTV menu. VNAV altitudes for waypoints without a navigation database or

manually input VNAV altitude are automatically computed by the system using “look-ahead” rules. When “look-ahead” finds a further VNAV altitude constraint above the previous VNAV altitude constraint (i.e., climb commanded), an automatic VNAV altitude is continuously calculated for the waypoint based upon an immediate climb to the altitude constraint at the higher of actual climb angle or the climb angle setting (dynamic climb angle). When “look-ahead” finds a further VNAV altitude constraint below the previous VNAV altitude constraint (i.e., descent commanded), an automatic VNAV altitude is calculated for the waypoint based upon a descent to reach the VNAV altitude constraint at the associated waypoint using the descent angle setting. If no further VNAV altitude constraints are found, the automatic VNAV altitude is set to the last valid VNAV altitude constraint.

When a VNAV climb is desired, the boxes are drawn at a vertical position the higher of: (a) the dynamic climb angle emanating from the aircraft's present position (aircraft-referenced); (b) the dynamic climb angle emanating from the next waypoint VNAV altitude (geo-referenced forward); or (c) the climb angle setting emanating from the previous waypoint VNAV altitude (geo-referenced backward). The geo-referenced backward calculation is only considered when the current leg is part of a procedure and is designed to provide pilot awareness, if a specified climb gradient is not being met. Once the boxes intercept the VNAV altitude, further boxes are drawn with a zero angle to show a level off followed by a level flight segment. Because five boxes are shown, the level-off depiction becomes an anticipatory cue for the pilot. Climb guidance is depicted below.

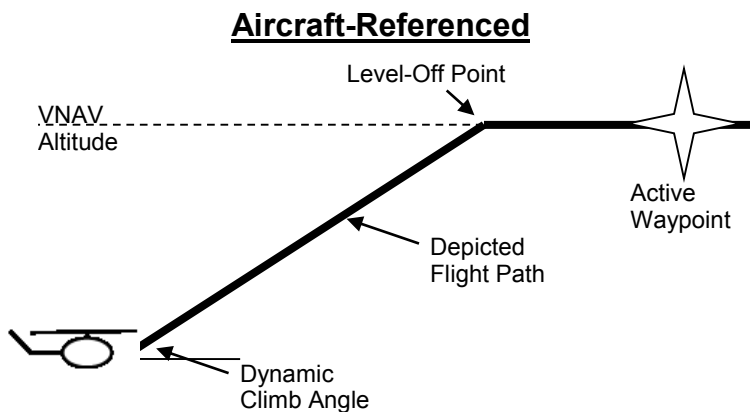


Figure 7-2: Highway in the Sky (Aircraft Referenced)

Geo-Referenced Backward

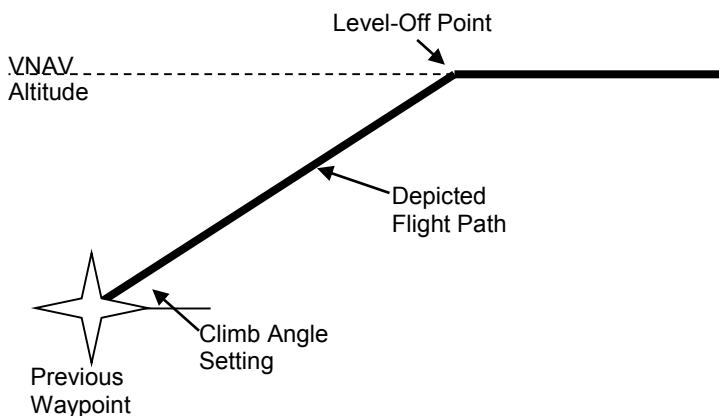


Figure 7-3: Highway in the Sky (Geo-Referenced Backward)

Geo-Referenced Forward

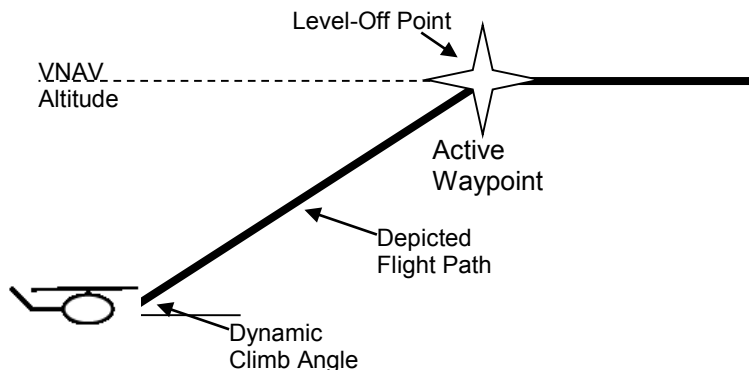


Figure 7-4: Highway in the Sky (Geo-Referenced Forward)

When a VNAV descent is desired, boxes are drawn with a zero angle until reaching a descent point. Further boxes are drawn downward at an angle corresponding to the descent angle setting. The descent point is defined by the intercept of a line emanating upward from the subsequent VNAV waypoint at the descent angle setting and a line representing level flight at the previous VNAV altitude. On the final approach segment of an IFR approach, descent angle and VNAV waypoint are defined as follows.

Table 7-2: Final Segment of IFR Approach, Descent Angle and VNAV Waypoint

Condition	VNAV Waypoint Definition	Descent Angle Definition
IFR Approach with valid Final Approach Segment data block	Glidepath Intercept Point as defined in Final Approach Segment data block	Descent Angle as defined in Final Approach Segment data block
No or invalid Final Approach Segment data block No intermediate waypoints exist between Final Approach Fix and Missed Approach Point.	Missed Approach Point location	Straight line from Final Approach Fix to Missed Approach Point location and altitudes.
No or invalid Final Approach Segment data block. Intermediate waypoints exist between Final Approach Fix and Missed Approach Point.	Missed Approach Point location	The steepest descent angle based upon straight lines from the Final Approach Fix and subsequent Intermediate Waypoints to Missed Approach Point location and altitudes.

On the final approach segment of a VFR approach procedure, the higher of the descent angle setting or 3° is used.

Because five boxes are shown, the descent point depiction becomes an anticipatory cue for the pilot. Descent guidance is depicted in Figure 7-5.



Figure 7-5: Highway in the Sky Final Approach Segments

Figure 7-5 creates an easily understood, yet safe, VNAV paradigm meeting the VNAV requirements current guidance. Simplicity is a primary objective. Further, the paradigm is biased towards keeping the aircraft at the highest altitude possible for the longest period of time, an important safety benefit for operators of single-engine aircraft. The climb paradigm automatically compensates for an aircraft's ability to climb more steeply than specified and also warns of being below a desired climb gradient when the aircraft is unable to meet the specified climb angle. The descent paradigm encourages flying stabilized approaches.

7.2.3. Waypoint Sequencing

Where automatic waypoint sequencing is suspended due to reasons 1, 2, or 4 in § 7.2, the EFIS automatically switches from TO operation to FROM operation when appropriate. If not suspended, automatic waypoint sequencing occurs upon the following conditions:

- 1) Bearing to the transition point (turn bisector for fly-by waypoint, active waypoint for fly-over waypoint) is more than 90° from the current course (i.e., transition from "TO" to "FROM" operation);
- 2) Aircraft location is within two turn diameters (based upon current True Airspeed and 15° angle of bank) of the active waypoint location; and
- 3) Aircraft heading is within 90° of the current course (i.e., generally pointed in the correct direction).

The desired flight path is created from a sequence of straight, left turning, and right turning leg segments designed to provide smooth skyway, GPS/SBAS CDI, and lateral autopilot guidance. Each leg between waypoints is composed of up to nine segments. Radii for turning segments (other than DME arc or Radius to a Fix segments) are automatically calculated with the parameter speed determined as follows:

- 1) If the waypoint is part of a DP and within 30 NM of the departure runway, speed is the preprogrammed Procedure Speed.
- 2) If the waypoint is part of a STAR and within 30 NM of the arrival runway, speed is the preprogrammed Procedure Speed.
- 3) If the waypoint is part of an IAP or VFR Approach Procedure, speed is the preprogrammed Procedure Speed.
- 4) If the waypoint is part of a Holding Pattern, speed is the preprogrammed Procedure Speed.
- 5) Otherwise, speed is the current True Airspeed or preprogrammed Procedure Speed, whichever is higher.

In all cases, if NavData derived speed limit is associated with the waypoint, speed is the lower of the NavData derived speed limit or the speed determined above.

7.2.4. Fly-Over Waypoints

For creating the desired flight path, each waypoint is designated as a fly-by waypoint or a fly-over waypoint. Waypoints are further subdivided into waypoints with a defined entry heading and waypoints with a defined exit heading. Waypoint auto-sequencing for fly-by waypoints occurs at the bisector of the turn. Waypoint auto-sequencing for fly-over waypoints occurs over the waypoint.

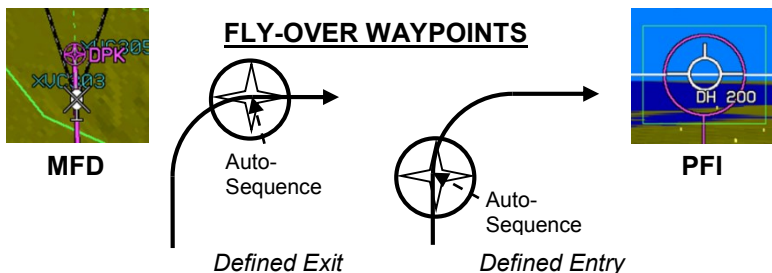


Figure 7-6: Fly-Over Waypoints

The following waypoints are Fly-Over with Defined Entry Heading:

- 1) Exit from holding pattern;
- 2) Exit from procedure turn;
- 3) Entry into holding pattern;
- 4) Missed Approach Point;
- 5) Phantom Waypoint (waypoint created by either inserting a waypoint into the active flight plan or performing the Direct-To function within the active flight plan -- avoids S-turns);
- 6) Last waypoint;
- 7) Start waypoint (waypoint created by creating a new active flight plan with the Direct-To function – avoids S-turns);
- 8) Reference (takeoff runway end) waypoint of a DP;
- 9) Waypoint leading into discontinuity; and
- 10) Altitude, DME, or Radial termination legs (ARINC 424 path types CA, FA, VA, CR, VR, CD, FD, and VD).
- 11) Waypoints marked as overfly in the navigation database.

The definitions of leg type designators are as follows.

Table 7-3: RNAV Path Terminator Leg Type

Path	Designator		Terminator
Constant DME arc	A	A	Altitude
Course to	C	C	Distance
Direct Track	D	D	DME Distance
Course from a Fix to	F	F	Fix
Holding Pattern	H	I	Next Leg
Initial	I	M	Manual Termination
Constant Radius	R	R	Radial Termination
Track Between	T	V	Heading To

Examples: **CF**= Course to Fix, and **FM**= Course from a Fix to a Manual Termination, etc. (See Table 9-5: Path Terminators for ARINC 424 Path-Terminator Leg Types.)

7.2.5. Fly-By Waypoints

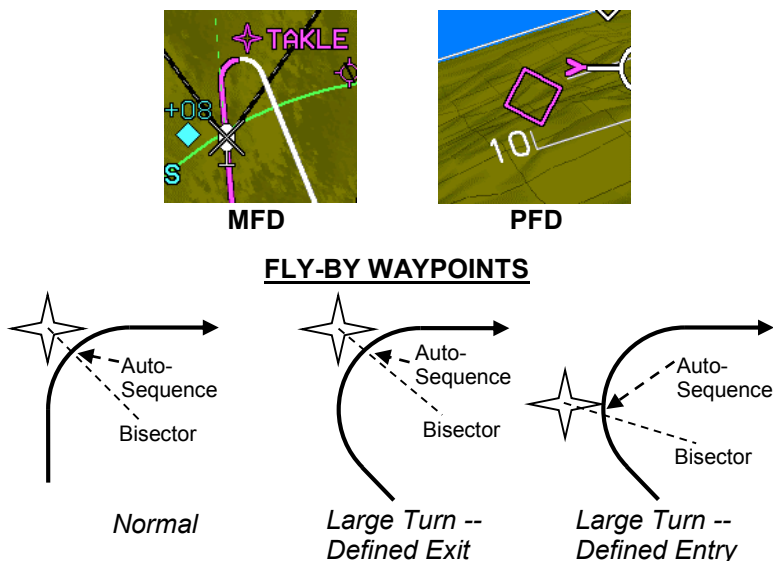


Figure 7-7: Fly-By Waypoints

The following waypoints are Fly-Over with Defined Exit Heading:

- 1) Entry into procedure turn; and
- 2) Waypoint exiting a discontinuity with the exception of phantom waypoints or DP reference waypoints;
- 3) First waypoint with the exception of start waypoints or DP reference waypoints;
- 4) Course to a fix legs that are not to the FAF/FAWP are Fly-By with defined Entry Heading. All other waypoints are Fly-By with the entry adjusted and have a defined Exit Heading.

NOTE:

Entry adjustments should be expected anytime a turn exceeds 120°. Turns greater than 120° should not be used in conjunction with RNP routes. (RNP standards specifically exclude such turns from RNP requirements.)

Leg segments for paths are constructed by the IDU as follows.

Table 7-4: Leg Segments for Paths Constructed by the IDU

Path Type	Entry Waypoint	Exit Waypoint	# of Segments and Description
Straight Leg, DME Arc, or Radius to a Fix	Fly-By	Fly-By	2nd Half of Fly-By turn at Entry Waypoint. WGS-84 Geodesic or Arc path from Entry to Exit turns. 1st Half of Fly-By turn at Exit Waypoint.
	Fly-By	Fly-Over Defined Exit Heading	2nd Half of Fly-By turn at Entry Waypoint. WGS-84 Geodesic or Arc path from Entry to Exit turns. Turn to exit heading prior to Exit Waypoint.
	Fly-By	Fly-Over Defined Entry Heading	2nd Half of Fly-By turn at Entry Waypoint. WGS-84 Geodesic or Arc path from Entry turn to Exit Waypoint.
	Fly-Over Defined Exit Heading	Fly-By	WGS-84 Geodesic or Arc path from Entry Waypoint to Exit turn. 1st Half of Fly-By turn at Exit Waypoint.
	Fly-Over Defined Exit Heading	Fly-Over Defined Exit Heading	WGS-84 Geodesic or Arc path from Entry Waypoint to Exit turn. Turn to exit heading prior to Exit Waypoint.

Table 7-4: Leg Segments for Paths Constructed by the IDU

Path Type	Entry Waypoint	Exit Waypoint	# of Segments and Description
	Fly-Over Defined Exit Heading	Fly-Over Defined Entry Heading	WGS-84 Geodesic or Arc path from Entry Waypoint to Exit Waypoint.
	Fly-Over Defined Entry Heading	Fly-By	Turn from entry heading after Entry Waypoint. WGS-84 Geodesic or Arc path from Entry to Exit turns. 1st Half of Fly-By turn at Exit Waypoint.
	Fly-Over Defined Entry Heading	Fly-Over Defined Exit Heading	Turn from entry heading after Entry Waypoint. WGS-84 Geodesic or Arc path from Entry to Exit turns. Turn to exit heading prior to Exit Waypoint.
	Fly-Over Defined Entry Heading	Fly-Over Defined Entry Heading	Turn from entry heading after Entry Waypoint. WGS-84 Geodesic or Arc path from Entry turn to Exit Waypoint.

Table 7-4: Leg Segments for Paths Constructed by the IDU

Path Type	Entry Waypoint	Exit Waypoint	# of Segments and Description
Procedure Turn	Fly-Over Defined Exit Heading	Fly-Over Defined Entry Heading	<p>WGS-84 Geodesic path from Entry Waypoint on outbound heading for 30 seconds.</p> <p>Turn to procedure turn heading (45°).</p> <p>Outbound on procedure turn heading for 72 seconds.</p> <p>Turn to inbound heading (135°).</p> <p>WGS-84 Geodesic path to Exit Waypoint. Entry Waypoint and Exit Waypoint are same point.</p> <p>Turn to proper entry procedure heading. This heading varies. For a parallel entry, it is 180° from the holding course. For direct and teardrop entries, it is the heading required to get to entry of inbound turn.</p>

Table 7-4: Leg Segments for Paths Constructed by the IDU

Path Type	Entry Waypoint	Exit Waypoint	# of Segments and Description
Holding Pattern	Fly-Over Defined Entry Heading	Fly-Over Defined Entry Heading	<p>WGS-84 Geodesic path to entry of inbound turn.</p> <p>Inbound turn. Degree of turn varies depending upon entry procedure and heading.</p> <p>WGS-84 Geodesic path to holding fix for direct and teardrop entries. WGS-84 Geodesic path to entry of turn to holding pattern heading for parallel entries.</p> <p>Turn to holding pattern heading for parallel entries. This leg is not used for direct and teardrop entries.</p> <p>Turn to holding pattern outbound leg (180°).</p> <p>Holding pattern outbound leg (length based upon either time or distance as specified by navigation database).</p> <p>Turn to holding pattern inbound leg (180°).</p> <p>Holding pattern inbound leg (length based upon either time or distance as specified by navigation database).</p>

7.2.6. Direct-To

If the IDU generates a WGS-84 geodesic path to a designated “To” fix, the aircraft captures this path without “S-turning” or undue delay. Where the selected “To” fix is in the active flight plan, the required transition is created as follows:

- 1) A phantom waypoint is created at the current aircraft location.
- 2) The leg prior to the Phantom waypoint is designated as a discontinuity.
- 3) The Phantom waypoint is designated as a Fly-Over Defined Entry Heading waypoint where the entry heading is current aircraft track.

Where the selected “To” fix is not in the active flight plan, the required transition is created as follows:

- 1) A new active flight plan is created from “Start” (current aircraft location) to the “To” fix.
- 2) “Start” waypoint is designated as a Fly-Over Defined Entry Heading waypoint where the entry heading is current aircraft track.

7.3. Magnetic Course

The source of magnetic variation used for paths defined using magnetic course is in accordance with the following:

- 1) If the leg is part of a database terminal area procedure and the magnetic variation is specified by the State for the procedure, the magnetic variation to be used is the value specified.
- 2) If the leg is not part of a procedure and the active fix is a VOR, the magnetic variation to be used is the published station declination for the VOR.
- 3) If the leg is not part of a procedure and the terminating fix is not a VOR, the magnetic variation to be used is defined by the system using an internal model.

The EFIS has the capability of computing magnetic variation at any location within the region where flight operations may be conducted using Magnetic North reference. The assigned magnetic variation is calculated using the NIMA GEOMAG algorithm and the World

Magnetic Model appropriate to the five-year cycle in a MAGVAR database.

7.3.1. AHRS Modes for Heading Source

AHRS Slaved—EFIS Magnetic North: Standard mode of operation. Everything is displayed relative to Magnetic North drift free.

AHRS Slaved—EFIS True North: Everything is displayed relative to True North with drift free heading. This is the preferred way to operate in areas where navigation is done relative to True North. (See Section 9 Appendix for limitations on Earth's magnetic flux horizontal field)

AHRS Free/"DG"—EFIS Magnetic North: Use this mode when operating around significant magnetic disturbances in areas where navigation is done relative to Magnetic North. Ensure the compass rose is slewed to a Magnetic North value.

AHRS Free/"DG"—EFIS True North: Method of operation in high-latitude areas where navigation is accomplished relative to True North. Heading is not drift free and requires periodic correction. This mode may also be used when operating around significant magnetic disturbances in areas where navigation is done relative to True North. Ensure the compass rose is slewed to a True North Value.

7.3.2. GPS Altitude

WGS-84 ellipsoid altitude received from the GPS/SBAS is converted to geodetic (MSL) altitude using the EGM 2008 geoidal database which is revised on a 12-year cycle.

7.3.3. Dead Reckoning

The EFIS provides a Dead Reckoning capability and is active, whenever a valid position is not being sent by the GPS/SBAS sensor. The EFIS projects the last known GPS/SBAS position forward using TAS and heading corrected for last known wind as it continues to navigate using this position and the active flight plan. The system provides the capability to determine bearing to an airport based upon the dead reckoning position.

7.3.4. Geodesic Path Computation Accuracy

The cross-track path deviation error between the computed path used to determine cross-track deviations and the true WGS-84 geodesic is less than 10% of the horizontal alert limit of the navigation mode applicable to the leg containing the path.

7.3.5. Parallel Offsets

The parallel offset is a route parallel to, but offset from, the original active route. The basis of the offset path is the original flight plan leg(s) and one or more offset reference points as computed by the IDU. The computed offset reference points are located so they lie on the intersection of lines drawn parallel to the host route at the desired offset distance and the line that bisects the track change angle. An exception to this occurs where the parallel offset ends. In this case, the offset reference point is located abeam of the original flight plan waypoint at the offset distance.

The parallel offset function is not available nor applies to:

- 1) Legs that are parts of approach procedures (IFR Approach or VFR Approach);
- 2) Legs that are ARINC 424 path types other than DF or TF (i.e., any path type that is not straight/geodesic or has a dynamically calculated beginning or ending); or
- 3) Legs that begin at an aircraft starting position (e.g., reference waypoint in a DP or Start/Phantom waypoints created by the Direct-To function).

The parallel offset function does not propagate through:

- 1) Any waypoint at the beginning or end of a route discontinuity;
- 2) Any waypoint at the beginning or end of a prohibited leg type; or
- 3) A waypoint with an unreasonable path geometry (defined as a turn greater than 120°).

When the parallel offset function begins or ends within a flight plan due to the above constraints, parallel offset entry or exit waypoints are inserted into the flight plan. Discontinuities precede parallel offset entry waypoints and follow parallel offset exit waypoints. This allows the pilot to navigate to and from the parallel offset as required. A parallel offset entry waypoint (PTK-) is shown in Figure 7-8.



Figure 7-8: Parallel Offset Entry Waypoint (AW-109SP)

The IDU has the capability to provide guidance to parallel tracks at a selected offset distance. When executing a parallel offset, the navigation mode and all performance requirements of the original route in the active flight plan are applicable to the offset route. The IDU provides for entry of offset distance in increments of 1 nm, left or right of course and capable of offsets of at least 20 nm. The IDU is operating in offset mode is clearly indicated with advisory labels.

When in offset mode, the IDU provides reference parameters (e.g., cross-track deviation, distance-to-go, time-to-go) relative to the offset path and offset reference points. Annunciation is given to the flight crew prior to the end of the offset path, **PTK ENDING**, with sufficient time to return to the original path. Once a parallel offset is activated, the offset remains active for all flight plan route segments until removed automatically (i.e., by transitioning through a parallel track exit waypoint), until the flight crew enters a “Direct-To” routing or activates a new flight plan route, or until flight crew (manual) cancellation.

The EFIS provides guidance to parallel tracks at a selected offset distance. When executing a parallel offset, the navigation mode and all performance requirements of the original route in the active flight plan are applicable to the offset route. The EFIS provides for entry of offset distance in increments of 1 NM, left or right of course, and is capable of offsets of at least 20 NM. When the IDU is operating in offset mode, it is clearly indicated with blue letters on a black background advisory label (**PTK = 0 XXNM**).

mode, the EFIS provides reference parameters (e.g., cross-track deviation, distance-to-go, time-to-go) relative to the offset path and offset reference points.

7.4. Default GPS/SBAS Navigation Modes

In the default GPS/SBAS operating mode, the IDU has Enroute, Terminal, LNAV Approach, LNAV/VNAV Approach, LP Approach, LPV Approach, VFR Approach, and Departure navigation modes. Mode annunciation, alert limits (horizontal and vertical), and CDI FSD (horizontal and vertical) are automatically determined by navigation mode as follows.

Navigation Mode	Annunciation
Enroute	None
Terminal	TERMINAL
LNAV Approach	LNAV APPR
LNAV/VNAV Approach	LNAV/VNAV APPR
LP Approach	LP APPR
LPV Approach	LPV APPR
VFR Approach	VFR APPR
Departure	TERMINAL

The system automatically switches to default navigation modes based upon region of operation as follows.

Table 7-6: Default Navigation Modes Based Upon Region of Operation

Default Navigation Mode	Definition of Region
Departure	Selected when the active waypoint is the first waypoint of a departure or Missed Approach Procedure <u>and</u> the active leg heading is aligned ($\pm 3^\circ$) with the active runway heading. Also set when the active waypoint is the MAWP but a missed approach has been manually activated*.
VTF Approach (LNAV, LNAV/VNAV, LP or LPV)	VTF IFR Approach has been selected; <u>and</u> within 30 NM of the active runway*; <u>and</u> the FAWP is the active waypoint*; <u>and</u> the bearing to the FAWP is within 45° of the final approach segment track (treated as a mode entry criteria)*; <u>and</u> the desired track to FAWP is within 45° of the final approach segment track (treated as a mode entry criteria).
Approach (LNAV, LNAV/VNAV, LP or LPV)	IFR Approach has been selected; <u>and</u> within 30 NM of the active runway*; <u>and</u> the MAWP or the FAWP is the active waypoint; <u>and</u> if the FAWP is the active waypoint: the bearing to the FAWP is within 45° of the final approach segment track (treated as a mode entry criteria)*; <u>and</u> the desired track to FAWP is within 45° of the final approach segment track (treated as a mode entry criteria)*; <u>and</u> either the segment leading into the FAWP is not a holding pattern or the pilot has elected to continue out of holding.

Table 7-6: Default Navigation Modes Based Upon Region of Operation

Default Navigation Mode	Definition of Region
VFR Approach	VFR Approach has been selected*; <u>and</u> within 30 NM of the active runway*; <u>and</u> the active runway is the active waypoint.
Terminal	Not in Departure Mode; <u>and</u> Not in Approach Mode; <u>and</u> The active waypoint is part of a departure <u>or</u> the active waypoint and previous waypoint are parts of an arrival or approach <u>or</u> within 30 NM of the departure airport, arrival airport, or runway.
Enroute	Not in Departure, Approach, or Terminal Modes.

NOTE:

During RNP 0.3 Approach (manually or coded) the scale remains in RNP 0.3.

7.5. GPS/SBAS CDI Scale
Table 7-7: Summary of Changes In Cross-Track FSD

	To Enroute	To Terminal	To Approach
From Enroute		Change from ± 2 NM FSD to ± 1 NM FSD over distance of 1 NM; start transition when entering terminal mode.	
From Terminal	Change from ± 1 NM FSD to ± 2 NM FSD over distance of 1 NM; start transition when entering enroute mode.		If VTF, switch immediately. Otherwise, change from ± 1 NM FSD to approach FSD over distance of 2 NM; start transition at 2 NM from FAWP
From Approach		Change to ± 1 NM.	
From Departure		If initial leg is aligned with runway, change from ± 0.3 NM FSD to ± 1 NM FSD at the turn initiation point of the first fix in the departure procedure.	

NOTE:

For RNP 0.3 routes, the Time to Alert is the same as for the approach. For RNP 0.3, the EFIS uses a 10 second TTA when using GPS-only, and a 2-second TTA when using EGNOS.

7.6. Approach Type Selection

The IDU automatically selects the approach type (LNAV, LNAV/VNAV, LP, or LPV) when entering approach mode. The automatically-selected approach type is selected with the following order of precedence and prerequisites:

1) **LPV:**

- a) LPV Enable is enabled;
- b) ARINC-424 “Level of Service” indicates LPV minimums are published;
- c) Valid long-term, fast, and ionospheric SBAS corrections are available and being applied to at least 4 GPS satellites;
- d) Final Approach Segment data block exists and passes CRC check; and
- e) Horizontal and vertical alert limits from Final Approach Segment data block are predicted to be supported.

2) **LP:**

- a) LPV Enable is enabled;
- b) ARINC-424 “Level of Service” indicates LP minimums are published;
- c) Valid long-term, fast, and ionospheric SBAS corrections are available and being applied to at least 4 GPS satellites;
- d) Final Approach Segment data block exists and passes CRC check; and
- e) Horizontal alert limit from Final Approach Segment data block is predicted to be supported.

3) **LNAV/VNAV:**

- a) ARINC-424 “Level of Service” indicates LNAV/VNAV minimums are published;
- b) If a Final Approach Segment data block exists, LPV Enable is enabled;
- c) If a Final Approach Segment data block exists, it passes CRC check; and

- d) Horizontal alert limit of 556 m. (.3 NM) is predicted to be supported.

NOTE:

Because the IDU inherently supports barometric VNAV, it is not a prerequisite for the vertical alert limit to be predicted or supported.

Nor is it a prerequisite for valid long-term, fast, and ionospheric SBAS corrections be available and applied to at least four GPS satellites. Rather, the vertical alert limit (50 m) and SBAS correction tests are used to determine whether to present guidance based upon GPS altitude or barometric altitude.

- 4) **LNAV:** This is the default approach type and is selected when none of the above selections are made. There are no prerequisites for selecting LNAV.

The IDU continuously displays the approach type (mode indication) after selection. The IDU does not degrade the approach type after selection unless the approach procedure is reselected or changed.

NOTE:

These GPS/SBAS modes still appear during a ground based approach such as an ILS approach (see Figure 7-9).

NOTE:

Some instrument procedures include notes saying “RNP 0.3 required” and are coded as an RNAV procedure. In these cases, manual RNP will have to be selected to see the RNP and ANP values on the PFD.



Figure 7-9: GPS Mode (LNAV APPR)

7.6.1. Approach Path Definition

Normal IAP path definitions are as specified in the procedure contained in the navigation database. Deviations are provided with respect to the active leg of the approach procedure.

7.7. VTF IFR Approach

In addition, the IDU provides the capability for the pilot to manually select a VTF IFR approach, indicating the pilot does not intend to fly the entire procedure. When a VTF IFR approach is selected, the IDU creates an “IP” waypoint on the extended final approach course to provide deviations relative to the extended final approach course. The “IP” is designated as a fly-over defined exit heading waypoint, and the leg prior to the “IP” is designated as a discontinuity. Until the FAWP has been sequenced, the IDU indicates a VTF IFR approach has been selected (with mode annunciation **VECTORS**) to advise the pilot guidance is not relative to a published approach path and TERPS or ICAO DO 8168 clearances are not assured.

7.8. VTF VFR Approach



The IDU also provides the capability for the pilot to manually select a VFR approach to a runway or user waypoint with a defined approach bearing. When a VFR approach is selected, the IDU creates an “IP” waypoint approximately 12 NM on the extended final approach course to provide deviations relative to the extended final approach course. The “IP” is designated as a fly-over defined exit heading waypoint, and the leg prior to the “IP” is designated as a discontinuity.

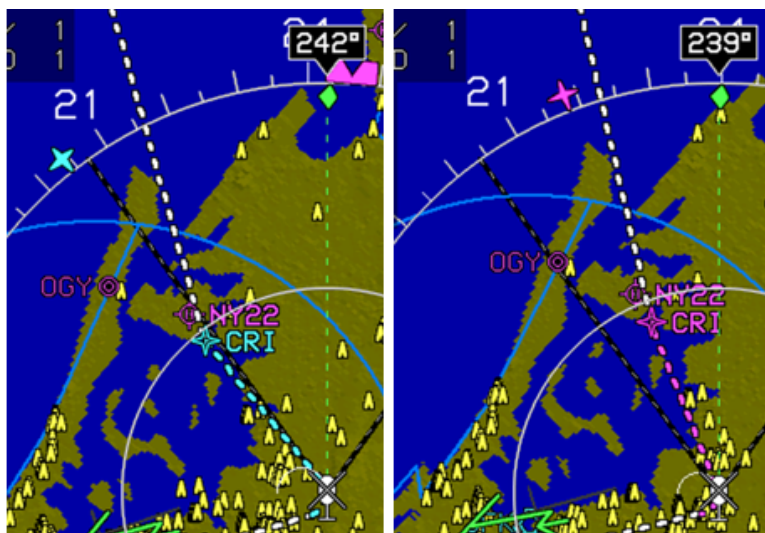


During this VTF IFR approach, the aircraft is proceeding towards the IP. Since the IP is designated as a discontinuity, proceeding direct is not possible. When attempting to proceed direct to the IP, only the active leg between the IP and RW01 is activated.

Figure 7-10: Navigating to FAF on VTF VFR Approach

7.9. Missed Approach and Departure Path Definition

The pilot may initiate the missed approach with manual action. Once on the final approach segment (dashed line course similar to instrument approach chart portrayal), the pilot has the option to initiate an immediate missed approach or to arm the system to execute the missed approach at the MAWP. When arming the missed approach, the pilot may take this action before crossing the MAWP, in which case the equipment arms the missed approach for automatic initiation at the MAWP. If a missed approach is not initiated prior to crossing the MAWP, the IDU automatically switches to FROM mode at the MAWP and continue on the same course.



AW-109SP Missed
Approach dashed line

Other Rotorcraft Missed
Approach dashed line

Figure 7-11: Missed Approach and Departure Path

If the pilot initiates the missed approach, the IDU provides guidance relative to the procedure. If a missed approach is armed prior to crossing the MAWP, the desired path, to and after the MAWP, is defined by the procedure. If the first leg in the missed approach procedure is not a straight path aligned within 3° of the final approach course, the FSD changes to terminal mode FSD (± 1 NM) when the missed approach is initiated. Otherwise, the FSD changes to ± 0.3 NM, when the missed approach is initiated (departure mode), and changes to terminal mode FSD (± 1 NM) at the turn initiation point of the first waypoint in the missed approach procedure.

The pilot may manually select DP guidance and, if the first leg in the DP is not a straight path aligned within 3° of the runway heading, terminal mode FSD (± 1 NM) is used. Otherwise, the FSD is ± 0.3 NM (departure mode) and changes to terminal mode FSD (± 1 NM) at the turn initiation point of the first waypoint in the DP.

7.10. Loss of Navigation Monitoring

The IDU continuously monitors, independent of any pilot action, for loss of navigation capability. In Manual RNP mode or Automatic

RNP mode prior to sequencing the FAWP, the loss of navigation caution is displayed using a 10 second time to alert if the RNP value is less than 2 NM and a 30 second time to alert otherwise. The **FAULTS** menu enables the pilot to distinguish the cause of the loss of navigation caution. The caution returns to its normal state upon termination of the responsible condition.

7.11. Discontinuities

Where the IDU is unable to construct a smooth flight path as described above due to active flight plan waypoint spacing (i.e., spacing too close for turn radius), a discontinuity is placed between the waypoints. When a discontinuity exists, no path nor skyway is drawn between the waypoints. The pilot cannot activate the waypoint exiting the discontinuity, as it is not possible to provide path guidance to this waypoint. Attempts to activate the waypoint exiting the discontinuity results in activation of the next waypoint or, if there is no next waypoint (i.e., end of active flight plan), activation of the waypoint leading into the discontinuity. Discontinuities are created where the NavData coding specifies a manual termination leg (ARINC 424 path types FM [Course from a Fix to Manual Termination] and VM [Heading to Manual Transition]).

7.12. Selection of an Instrument Procedure

When an instrument procedure is selected and active, the receiver notifies the pilot of the most accurate level of service supported by the combination of the GPS/SBAS signal, receiver, and selected approach, using naming conventions on the minima lines of the selected approach procedure. Once the level of service has been given, the EFIS operates in this mode for the duration of the procedure, unless the level of service becomes unavailable. The EFIS cannot change back to a more accurate level of service until the next time an approach is activated.

The following includes examples of the following procedures serving as sample Step-By-Step procedures. These examples are created from either AW-109SP configured displays or other rotorcraft configured displays as noted:

- 1) SID (Step-By-Step) with AW-109SP configuration.
- 2) STAR (Step-By-Step) with AW-109SP configuration.
- 3) ILS Instrument Approach (Step-By-Step) in other rotorcraft configuration.

- 4) LOC BC Instrument Approach (Step-By-Step) with AW-109SP configuration.
- 5) RNAV (GPS) Instrument Approach to LPV Minima (Step-By-Step) in other rotorcraft configuration.
- 6) NRST ILS Instrument Approach (Step-By-Step) in other rotorcraft configuration.
- 7) VOR DME Instrument Approach (Step-By-Step) in other rotorcraft configuration.
- 8) Copter RNAV (GPS) 028° (Step-By-Step) in other rotorcraft configuration.

7.12.1. Standard Instrument Departure (SID)

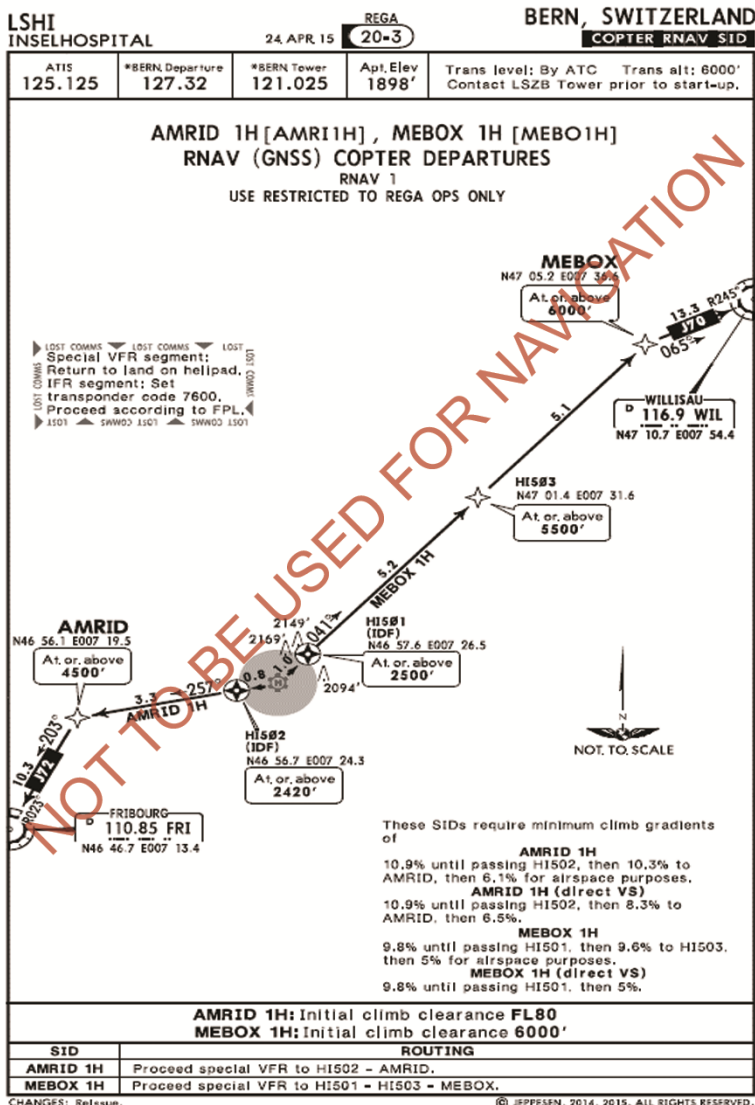


Figure 7-12: Standard Instrument Departure (SID)

- 1) Press **ACTV (L2)** and scroll **1** to LSHI and push to enter.
- 2) Scroll **1** to **DP..** and push to enter.
- 3) Scroll **1** to desired DP and push to enter.
- 4) The DP is loaded with **AMRID** transition.
- 5) Scroll **1** to one position past the end and press **ADD (R2)** then make selection of one option and push to enter.
- 6) Scroll **1** to desired airport (LSZG) and push to enter.
- 7) Now LSZG is the next waypoint in the ACTV flight plan.



Figure 7-13: Standard Instrument Departure (SID) (Step-by-Step)

7.12.2. Standard Terminal Arrival Route (STAR)

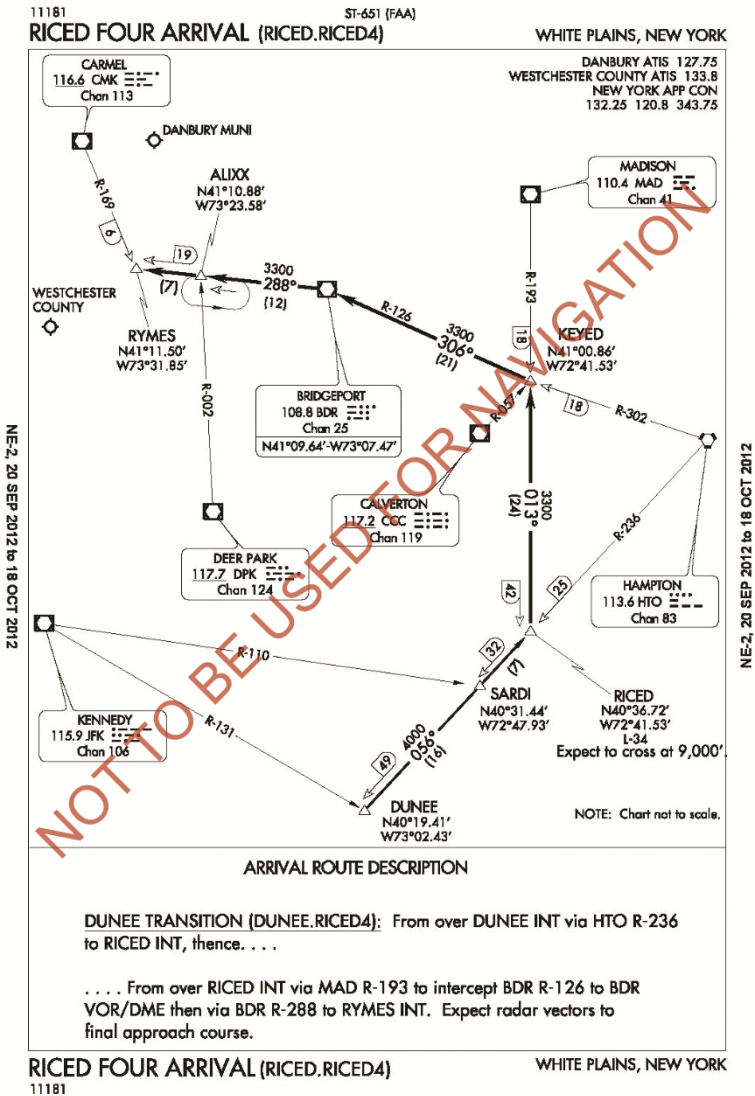


Figure 7-14: Standard Terminal Arrival Route (STAR)

If the selected waypoint is an airport with a published STAR, this option is available for selection from a list of available STARS, transitions, and runways. After selection, the appropriate STAR is created and displayed on the MAP page. Activating a STAR automatically deletes any pre-existing STAR and is inserted prior to any approach waypoints if previously entered.

- 1) The arrival airport must be in the ACTIVE flight plan and highlighted push **1** to enter.
- 2) Scroll **1** to **STAR:** and push to enter.
- 3) Scroll **1** to desired **TRANS:** and push to enter.
- 4) Scroll **1** to desired **RW:** and push to enter.
- 5) Press **ACTV (L2)** and view STAR in ACTIVE flight plan and current active waypoint.



Figure 7-15: STAR Procedure (Step-by-Step)

Assume ATC assigned a clearance to cross SARDI at 3500' 2 NM prior to crossing.

- 6) Press **ACTV (L2)** and scroll **1** to the waypoint in the clearance and push to enter.
- 7) Scroll **1** to **VNAV..** and push to enter.
- 8) Scroll **1** to enter assigned altitude, push to enter, and scroll **1** counter clockwise to enter -2 NM push to enter to comply with ATC crossing clearance.
- 9) The altitude is shown on the ACTIVE flight plan with the offset of 2 NM prior to reaching SARDI.

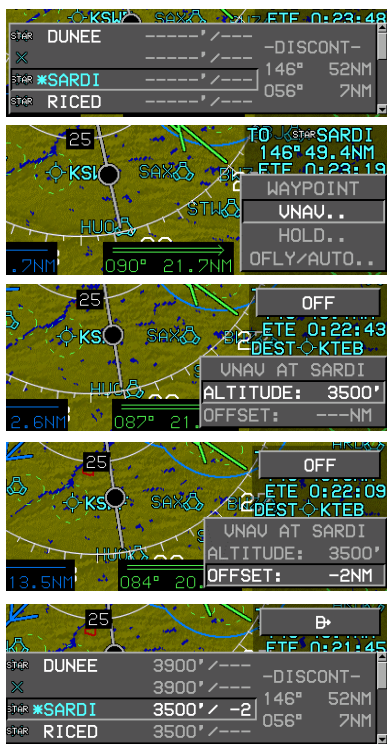


Figure 7-16: STAR Procedure (Step-By-Step) (Continued)

STARS normally terminate at a fix near the airport, then a radar vector or feeder route is used for transition to the approach phase of the arrival. If an instrument approach is activated during the STAR, the approach waypoints are inserted after the STAR.

7.12.3. ILS Instrument Approach

All approach operations typically begin with the same basic steps.

The following example selects the ILS RWY 10 at Louis Armstrong New Orleans INTL (KMSY). The PFD BUGS menu may be accessed on the PFD or Remote Bugs Panel if equipped.

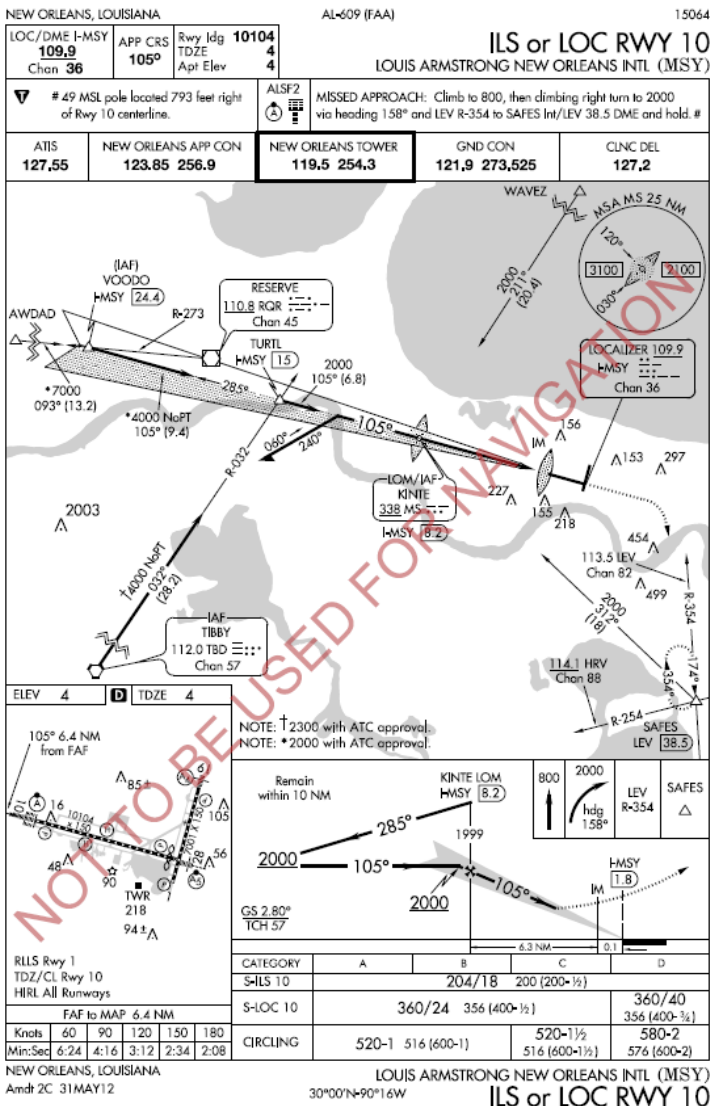


Figure 7-17: ILS RWY 10 (MSY)

- 1) Press **ACTV (L2)** and scroll **1** to desired airport and push to enter.
- 2) Scroll **1** to **IFR APPR..** and push to enter.
- 3) Scroll **1** to desired Approach, Transition, and RW and push to enter for each option.
- 4) The procedure turn at **KINTE** is depicted in the ACTIVE flight plan.



Figure 7-18: ILS RWY 10 (KMSY) (Step-By-Step)

- 5) Barometric Minima is set at 360' MSL, and DH is set to 200'.
- 6) PFD BUGS may be set on PFD or RBP if equipped.
- 7) The MAP shows orientation for turning inbound on the procedure turn for the approach.
- 8) The Outer Marker is shown with the magenta hoop and marker symbology above the CDI.



Figure 7-19: ILS RWY 10 (KMSY) (Step-By-Step) (Continued)

- 9) On the MFD press **MENU (R1)**, press **PAGE.. (R3)**, then scroll **1** to **HSI** and push to enter.
- 10) The Outer Marker symbol may be seen at the bottom.
- 11) At the FAF, press **ARM (L2)** to arm the missed approach procedure for automatic waypoint sequencing at the MAWP.
- 12) As an option, press **MENU (R1)** then **ZOOM ON (R3)** for a narrow field of view for realistic view of runway and surrounding areas.
- 13) Minimums have been reached in this view.

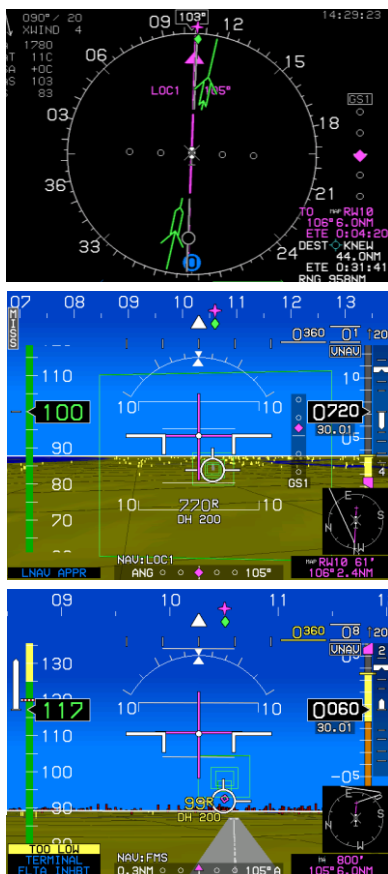


Figure 7-20: ILS RWY 10 (KMSY) (Step-By-Step) (Continued)

7.12.4. LOC Back Course Instrument Approach

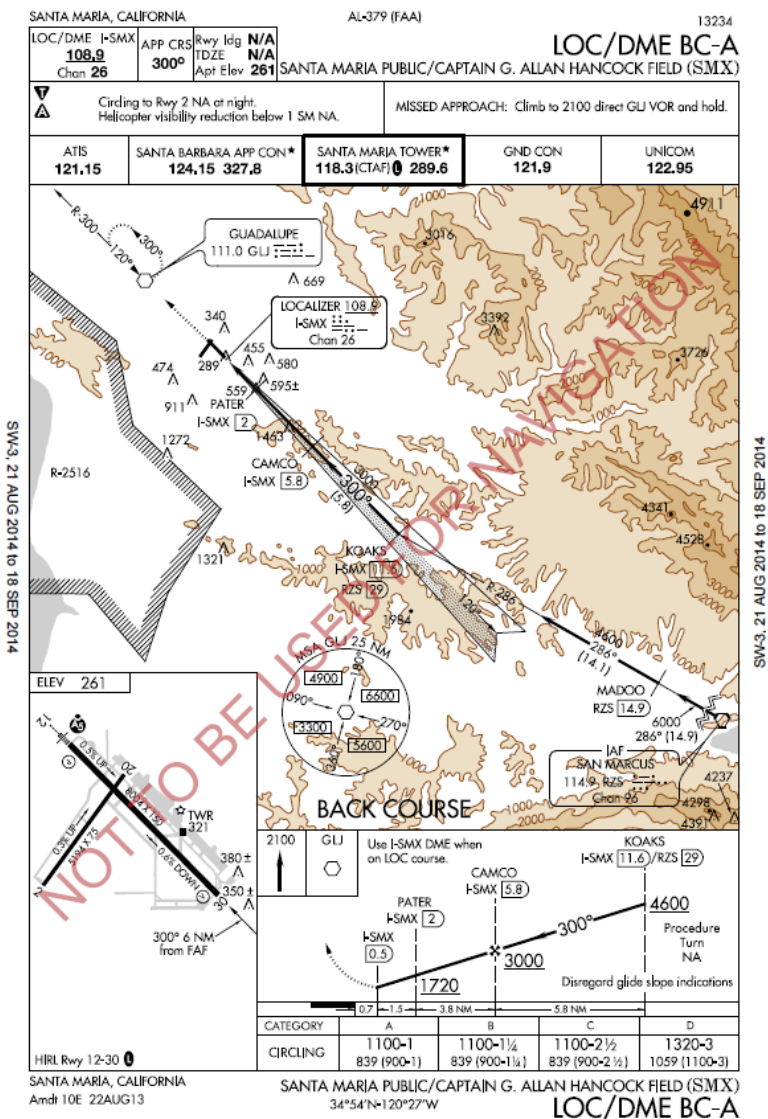


Figure 7-21: LOC Back Course Approach

- 1) Press **ACTV (L2)** and scroll **1** to **KSMX** and push to enter.
- 2) Scroll **1** to **IFR APPR..** and push to enter.
- 3) Scroll **1** to **LBCA** and push to enter.
- 4) Scroll **1** to desired transition and push to enter.
- 5) Scroll **1** to desired RW and push to enter.
- 6) An active waypoint is now created for direct to **RZS**.
- 7) ATC provides a clearance direct to **KOAKS** maintain **6000'**.
- 8) Press **ACTV (L2)** scroll **1** to **KOAKS** and press **0+ (R4)** then push **1** to enter.



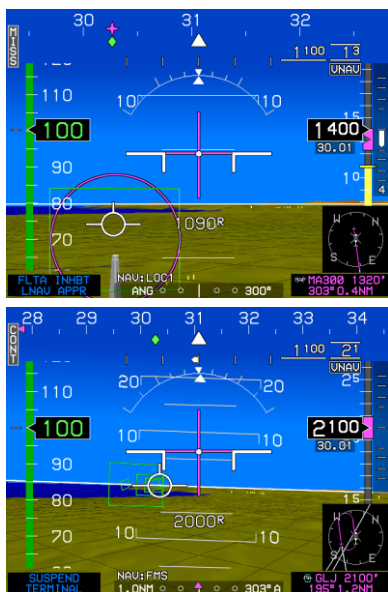
Figure 7-22: LOC Back Course Approach (Step-By-Step)

- 9) Passing the FAF, **ARM (L2)** appears without a **SUSPEND** advisory due to step-down fix ahead.
- 10) Press **OBS (L4)**. Scroll **1** to set final approach course 300° then push to enter.
- 11) Approaching step-down fix **PATER** with FLY BY symbol appearing as a point in space.
- 12) After passing **PATER**, **SUSPEND** appears until **ARM (L2)** is pressed to arm auto waypoint sequencing at the MAWP.



**Figure 7-23: LOC Back Course Approach (Step-By-Step)
(Continued)**

- 13) Press **MENU (R1)** then **ZOOM OFF (R3)** to return the PFD to normal wide field of view.
- 14) Once established in published holding, a **CONT** tile is present with **SUSPEND** until **CONT (L1)** is pressed.



**Figure 7-24: LOC Back Course Approach (Step-By-Step)
(Continued)**

7.12.5. RNAV (GPS) Instrument Approach to LPV Minima

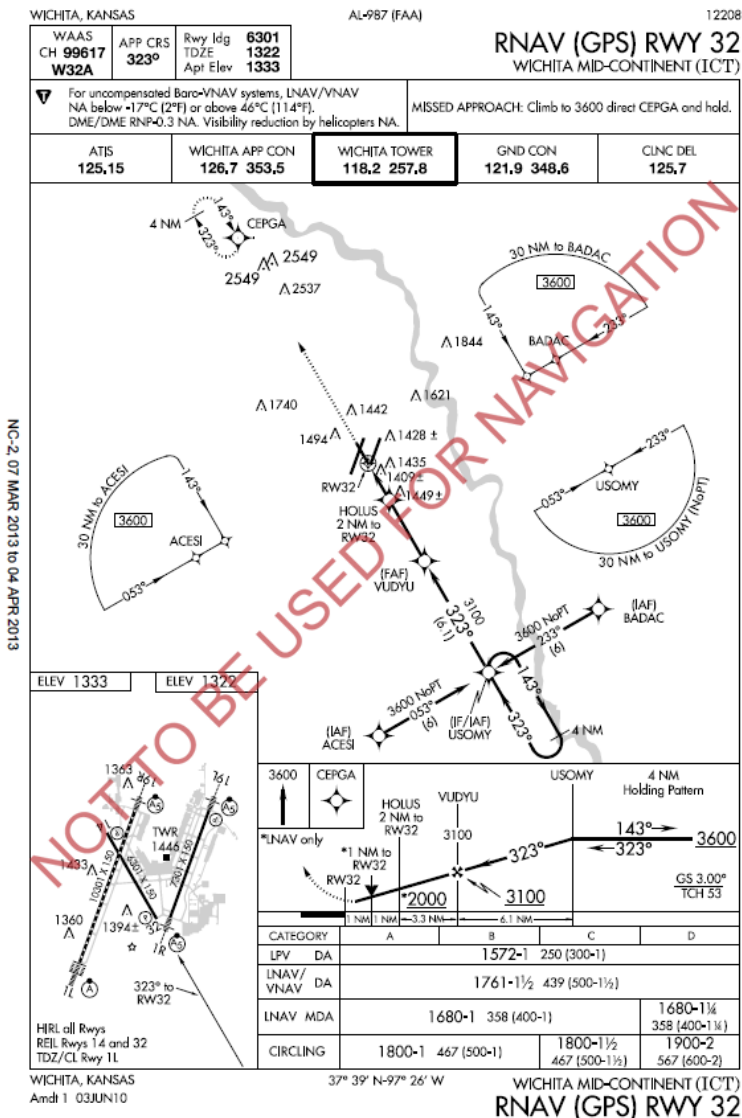


Figure 7-25: RNAV (GPS) Instrument Approach to LPV Minima

- 1) Select airport and **IFR APPR..** as in previous examples.
- 2) Press **ACTV (L2)** and scroll **1** to **KICT** and push to enter.
- 3) Scroll **1** to **IFR APPR..** and push to enter.
- 4) After reviewing the approach chart, scroll **1** to **RNAV32 (99617)** then push to enter.



NOTE:

Verify the WAAS channel 5-digit number is identical to instrument approach chart reference.

- 5) Scroll **1** to desired transition and runway then push to enter as described in previous examples.
- 6) Press **ACTV (L2)** and scroll **1** to desired waypoint and press **R4** then push **1** to enter.

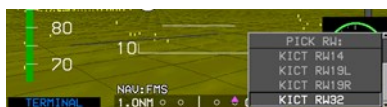


Figure 7-26: RNAV (GPS) Instrument Approach to LPV Minima (Step-By-Step)

- 7) Scroll **1** to desired map scale for best view.
- 8) Observe active leg magenta line and next leg in white.
- 9) Inside FAF, press **ARM (L6)** prior to step down FIX, HOLUS.
- 10) Approaching HOLUS on glidepath with Minimums set at 1580'.
- 11) Approaching Minimums on glidepath with runway insight.



Figure 7-27: RNAV (GPS) Instrument Approach to LPV Minima (Step-By-Step) (Continued)

7.13. Copter RNAV (GNSS) Approach

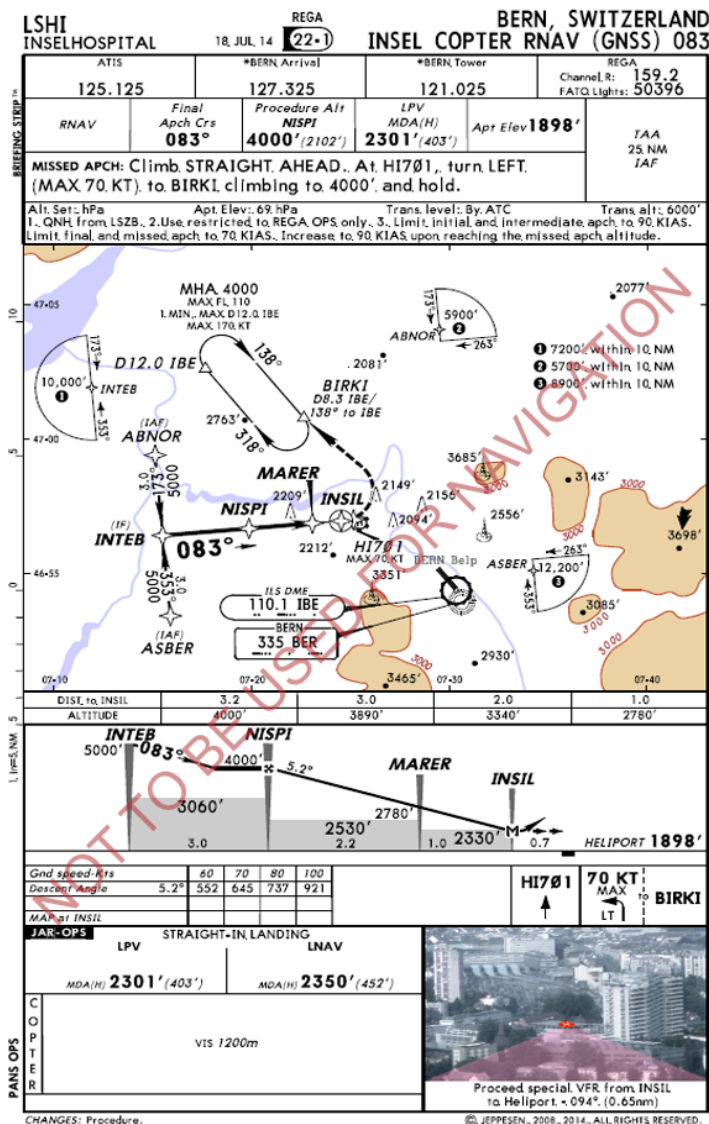


Figure 7-28: Copter RNAV (GNSS) Approach

- 1) Press **ACTV (L2)** and scroll **1** to **LSHI** and push to enter.
- 2) Scroll **1** to **IFR APPR..** and push to enter.
- 3) Since only one approach is available, push **1** to enter. Then scroll **1** to desired transition and push to enter.
- 4) Since only one runway is available, push **1** to enter.
- 5) On the MFD press **MENU (R1)**, press **PAGE.. (R3)**, then scroll **1** to **NAV LOG** and push to enter.
- 6) For a better view of the procedure, press **MENU (R1)** then scroll **1** to **ARC** and push to enter.



Figure 7-29: Copter RNAV (GNSS) Approach (Step-By-Step)

- 7) With the ARC view set, (see Figure 7-29) and MAP scale set by scrolling **1** clockwise for larger and counter clockwise for smaller, MAP is adjusted for best orientation and view.
- 8) Approaching NISPI FAF slightly below the glideslope on the LPV approach.
- 9) On glidepath approaching the FAF with the fly-by waypoint appearing ahead. With 70 IAS and groundspeed 54 Kts.



Figure 7-30: Copter RNAV (GNSS) Approach (Step-By-Step) (Continued)

- 10) Passing the FAF, press **ARM (L2)** to allow for arming the missed approach procedure upon passing the MAWP.
- 11) Press **MISS (L1)** anytime on the PFD, if a go-around is necessary, or it automatically begins sequencing the Missed Approach procedure upon passing the MAWP.
- 12) PFD BUGS must be set on the RBP in the AW-109SP.



Figure 7-31: Copter RNAV (GNSS) Approach (Step-By-Step)
(Continued)

NOTE:

When in LPV mode, the altitudes for the FAF, MAP, and any waypoints between the FAF and MAP are calculated based upon the internally protected FAS Data Block. Additionally, in LPV mode, the altitude presented for the MAP is, in fact, the altitude for the GPIIP (Glidepath Intercept Point) as contained in the FAS Data Block. The offset field is populated, because the altitude presented is not the altitude for the MAP. The abbreviated "GPI" indicates the vertical navigation offset is to the GPIIP.

For this approach, the altitude for NISPI has been calculated based upon FAS Data Block parameters as 3997'. The EFIS disregards the 4000' contained in the normal NavData coding as required by the TSO. The altitude at the GPIIP, which is downrange from INSIL is 1895'. Unless the missed approach is activated, the pilot can expect the AW-109SP AFCS to continue tracking the LPV glideslope beyond INSIL towards the GRIP. At 50' radar altitude, algorithms internal to the AFCS level the helicopter.

7.13.1. NRST ILS Instrument Approach

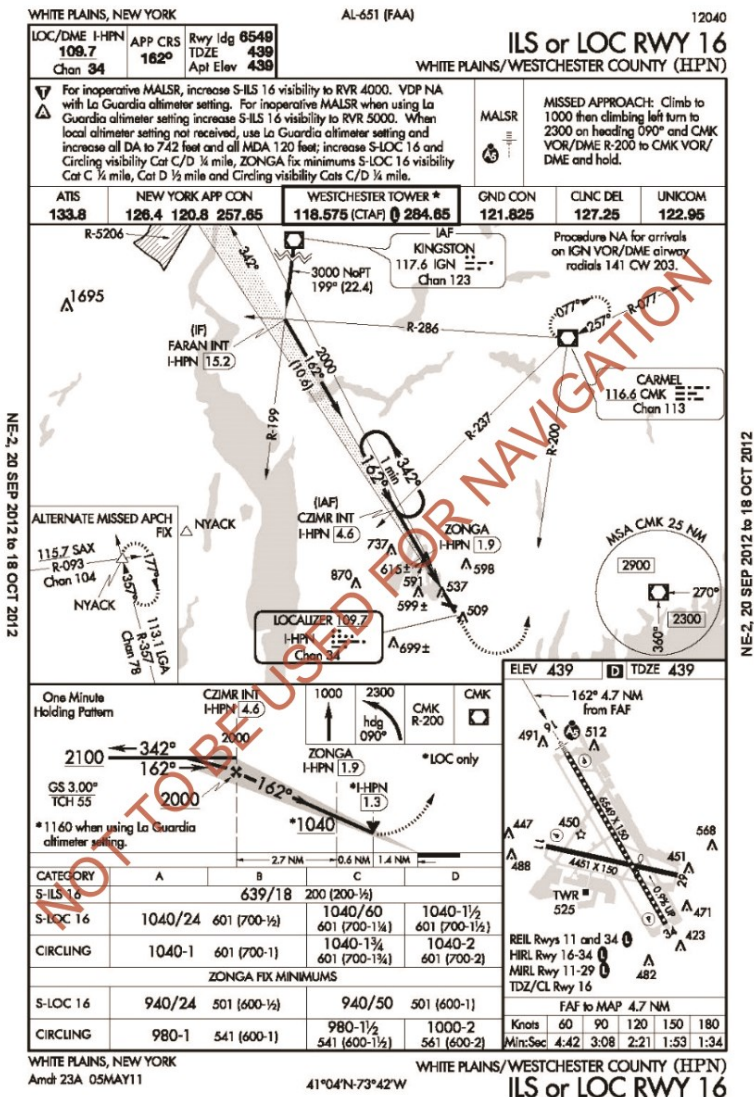


Figure 7-32: NRST ILS Instrument Approach

- 1) On the PFD, as shown here, or on the MFD, press **NRST (R3)** and scroll **1** to **NRST ILS..** and push to enter.
- 2) Scroll **1** to desired ILS option and push to enter.
- 3) Push **1** to CONFIRM ACTIVATE ILS.
- 4) Confirm active waypoint is the FAF for this ILS approach and manage HDG BUG which may have been turned on depending upon autopilot configuration.

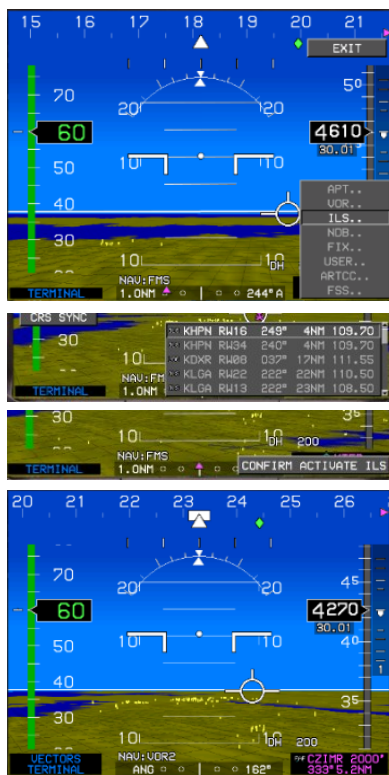


Figure 7-33: Nearest ILS Instrument Approach (Step-By-Step)

- 5) Press **ACTV (L2)** to view current ACTIVE flight plan and ACTIVE waypoint.
- 6) Press **OFF (R4)**, if ATC clearance allows for proceeding direct to FAF.
- 7) On PFD only, scroll **1** to open HDG menu and press **OFF (R4)** to turn off HDG BUG if appropriate.
- 8) On the MFD the active route is direct to the FAF. Adjust this display for best orientation with afore-mentioned controls.



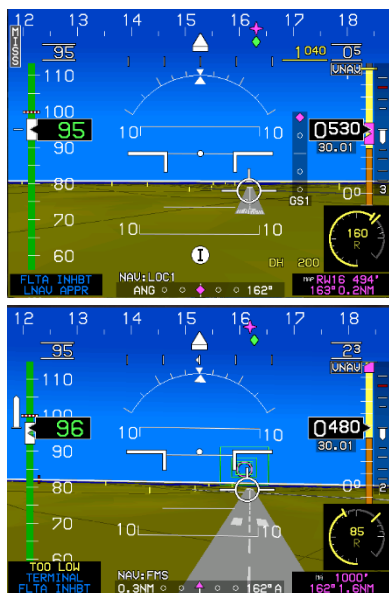
Figure 7-34: Nearest ILS Instrument Approach (Step-By-Step) (Continued)

- 9) Press **ACTV (L2)** to arm the Missed Approach procedure for automatic waypoint sequencing upon passing the MAWP.
- 10) Minimums have been set with PFD BUGS menu on the PFD or RBP if equipped. The LOC1 was automatically set with correct final approach course.
- 11) Below published Baro Minima and over the Middle Marker with the analog AGL indicator selected while below the glideslope.



Figure 7-35: Nearest ILS Instrument Approach (Step-By-Step) (Continued)

- 12) Passing the Inner Marker outside of the MAWP while going below the glidepath.
- 13) Beyond the MAWP with automatic switching of OBS to FMS with 0.3 NM FSD and HITS guidance for the missed approach procedure.



**Figure 7-36: Nearest ILS Instrument Approach (Step-By-Step)
(Continued)**

7.13.2. VOR/DME Instrument Approach

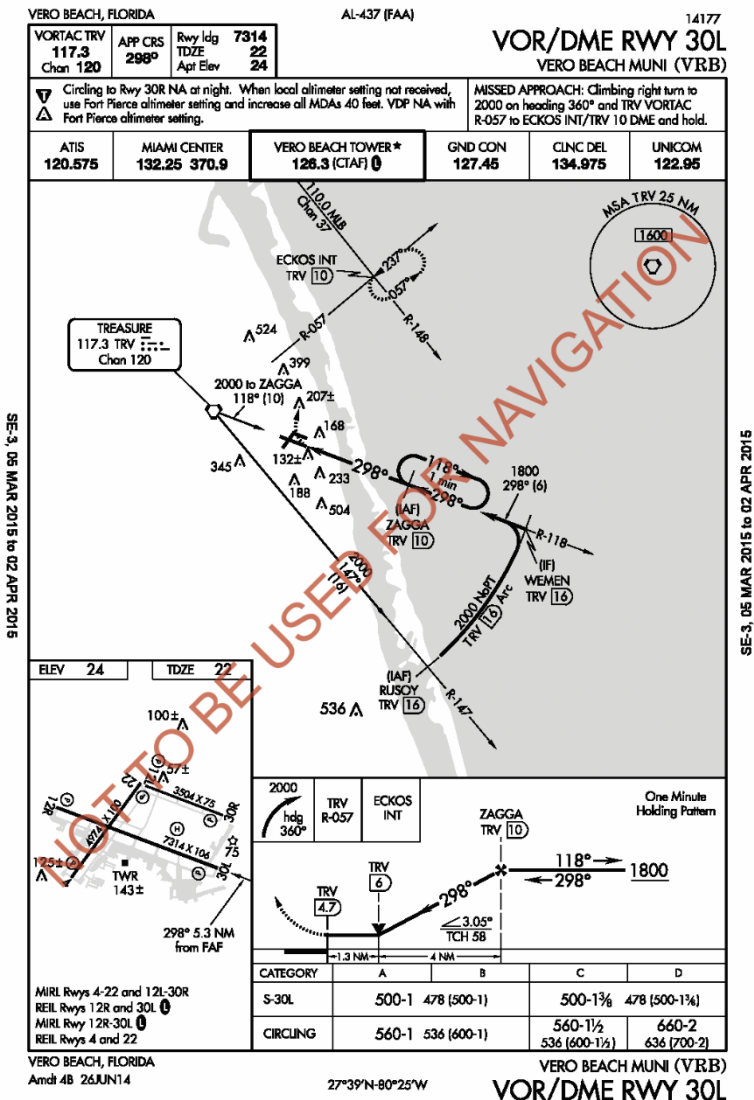


Figure 7-37: VOR/DME Instrument Approach

- 1) With KVRB already in the ACTIVE flight plan, scroll **1** to KVRB and push to enter.
- 2) Scroll **1** to **IFR APPR..** and push to enter.
- 3) Scroll **1** to desired approach procedure and push to enter.
- 4) Scroll **1** to desired transition and push to enter. (* = the most logical choice for your avenue of arrival.)
- 5) Scroll **1** to desired runway and push to enter.
- 6) The ACTIVE flight plan appears with active waypoint information.



Figure 7-38: VOR/DME Instrument Approach (Step-By-Step)

- 7) In this example, the EFIS is set to maintain 3000' MSL with the PFD BUGS menu or RBP, and the VNAV altitude is bypassed.
- 8) While in holding pattern at ZAGGA, auto waypoint sequencing is suspended until **CONT (L1)** is pressed.
- 9) The ASEL target altitude was turned off with PFD BUGS menu or RBP as applicable.

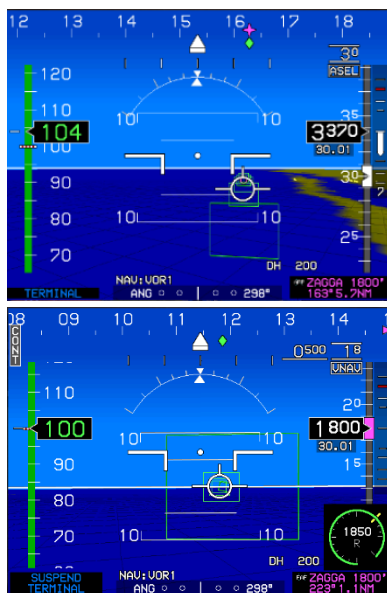


Figure 7-39: VOR/DME Instrument Approach (Step-By-Step) (Continued)

- 10) Passing the FAF, with **SUSPEND** until **ARM (L2)** is pressed.
- 11) Press **MENU (R1)** then **ZOOM ON (R3)** to narrow field of view is.
- 12) The runway now appears with markings as if seen through the windscreen.



- 13) During the Missed Approach procedure, the OBS automatically switches to FMS with 0.3 NM FSD and the first waypoint if the MAP as the active waypoint.



Figure 7-40: VOR/DME Instrument Approach (Step-By-Step) (Continued)

7.13.3. Copter RNAV (GPS) Instrument Approach

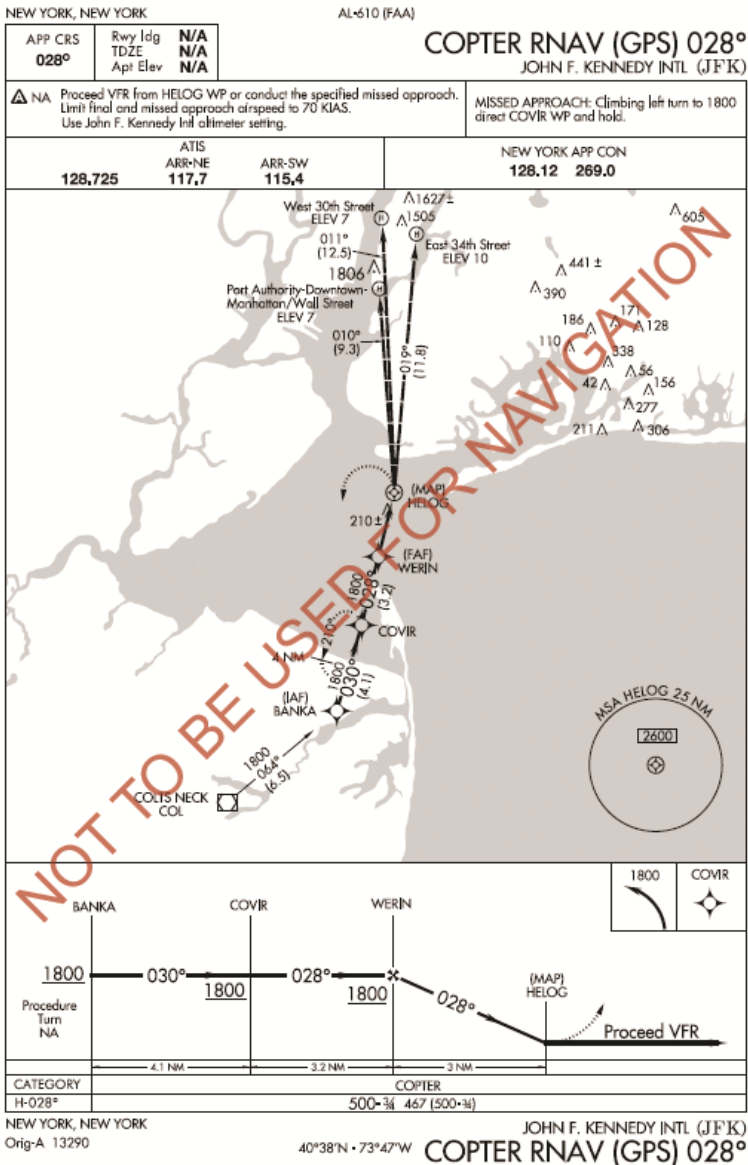


Figure 7-41: Copter RNAV (GPS) Approach

- 1) Press **ACTV (L2)**. With Heliport 6N5 as the highlighted active waypoint, press **INSERT (R2)** and either select from **NRST APT (L2)** list or enter **KJFK** with **1** and push to enter.
- 2) With ACTIVE flight plan open, scroll **1** to highlight **IFR APPR..** and push to enter.
- 3) Scroll **1** to highlight ***GPS028 H** and push to enter.
- 4) Scroll **1** to pick **TRANS:** to ***BANKA** and push to enter.
- 5) Scroll **1** to pick **RW:** Select any runway since a landing is planned at the Heliport at East 34th street (6N5).

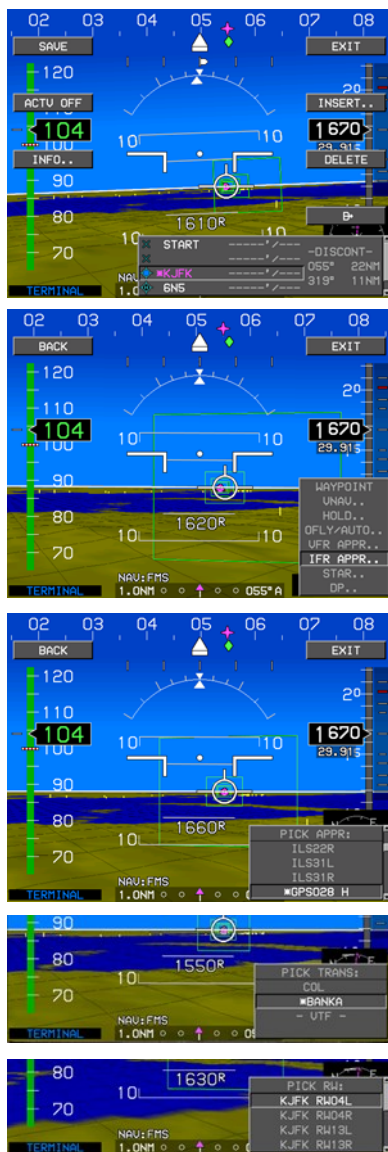
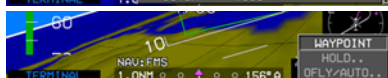


Figure 7-42: Copter RNAV (GPS) Approach (Step-By-Step)

- 6) ATC clears this flight for the Copter RNAV (GPS) 028 approach landing at 6N5 heliport maintain 1800'. Press **R4** and push **1** to enter.



- 7) If no other clearance is received, push **1** to accept crossing BANKA as a waypoint.



- 8) Press **MENU (R1)** then **BUGS.. (R2)** and **MINS.. (R3)** then scroll **1** to **MIN ALT..** and push to enter.

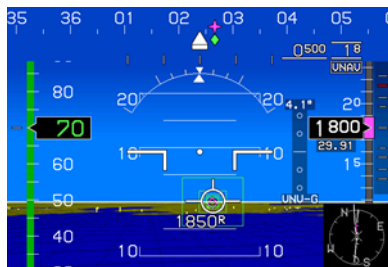


- 9) Scroll **1** to the published Minimum altitude 500' and push to enter.



Figure 7-43: Copter RNAV (GPS) Approach (Step-By-Step) (Continued)

- 10) 2.1 NM outside of the FAF with VDI appearing.



- 11) Inside the FAF on VNV-G glidepath and waypoint sequencing suspended.



- 12) Press **ARM (L2)** to arm the MAP and return to auto waypoint sequencing.



- 13) After passing **HELOG (MAWP)** press **ACTV (L2)** and scroll **1** to 6N5 press **⏏ (R4)** and push to enter.



Figure 7-44: Copter RNAV (GPS) Approach (Step-By-Step) (Continued)

- 14) With Heliport in sight and descending to 100' the Active Waypoint symbol appears over the heliport.



- 15) On the MFD, press **MENU (R1)** then **PAGE.. (R3)** and scroll **1** to **HOVER** and push to enter.

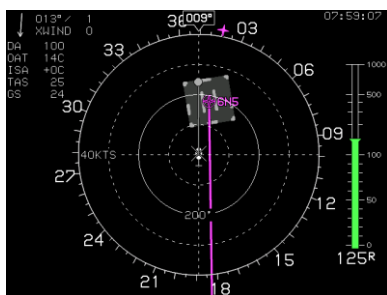
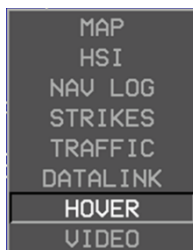


Figure 7-45: Copter RNAV (GPS) Approach (Step-By-Step) (Continued)

NOTE:

Navigation databases are expected to be current for the duration of the flight. If the Aeronautical Information Regulation and Control (AIRAC) cycle is due to change during the flight, operators, and pilots should establish procedures to ensure the accuracy of navigation data including suitability of navigation facilities used to define the routes and procedures for flight. Traditionally, this has been accomplished by verifying electronic data against paper products. Once acceptable means is to compare aeronautical charts (new and old) to verify navigation fixes prior to departure. If an amended chart is published for the procedure, the database must not be used to conduct the operation.

NOTE:

Pilots may notice a slight difference between the navigation information portrayed on the chart and their primary navigation display heading. Differences of three degrees or less may result from equipment manufacturer's application of magnetic variation and are operationally acceptable.

NOTE:

GPS receivers do not "Fail Down" to lower levels of service once the approach has been activated. If only the **VERT LON** appears, the pilot may elect to use the LNAV minima, if the rules under which the flight is operating to allow changing the type of approach being flown after commencing the procedure. If the lateral integrity limit is exceeded on an LP approach, a missed approach is necessary since there is no way to reset the lateral alarm limit while the approach is active.

Section 8 Terrain Awareness Warning System

Enhanced HTAWS and HTAWS

Table of Contents

SECTION 8	TERRAIN AWARENESS WARNING SYSTEM..	8-1
8.1.	ENHANCED HTAWS AND HTAWS (TERRAIN AWARENESS WARNING SYSTEM) FUNCTIONS.....	8-4
8.1.1.	<i>Terrain Display</i>	8-5
8.2.	FORWARD LOOKING TERRAIN ALERT FUNCTION	8-5
8.2.1.	<i>FLTA Modes</i>	8-6
8.2.2.	<i>GPS/SBAS Navigation Mode Slaving</i>	8-6
8.2.3.	<i>Default FLTA Mode</i>	8-6
8.3.	FLTA SEARCH ENVELOPE.....	8-8
8.3.1.	<i>FLTA Search Volume</i>	8-11
8.3.2.	<i>FLTA Alerts and Automatic Popup</i>	8-11
8.4.	EXCESSIVE CLOSURE RATE TO TERRAIN (GPWS MODE 2)....	8-14
8.5.	SINK RATE AFTER TAKEOFF OR MISSED APPROACH (GPWS MODE 3).....	8-16
8.6.	FLIGHT INTO TERRAIN WHEN NOT IN LANDING CONFIGURATION (GPWS MODE 4).....	8-17
8.7.	EXCESSIVE DOWNWARD DEVIATION FROM AN ILS GLIDESLOPE (GPWS MODE 5).....	8-18
8.8.	EXTERNAL SENSORS AND SWITCHES	8-20
8.9.	TAWS SYSTEM BASIC PARAMETER DETERMINATION.....	8-22
8.10.	TAWS AUTOMATIC INHIBIT FUNCTIONS (NORMAL OPERATION)	8-27
8.10.1.	<i>TAWS Automatic Inhibit Functions (Abnormal Operation)</i>	8-27
8.10.2.	<i>TAWS Manual Inhibit Functions</i>	8-30
8.11.	TAWS SELECTIONS ON PFD	8-30

List of Figures and Tables

TABLE 8-1: TAWS FUNCTIONS PROVIDED BY THE EFIS	8-4
FIGURE 8-1: TERRAIN DISPLAY	8-5
FIGURE 8-2: FLTA INHBT	8-6
FIGURE 8-3: DEFAULT FLTA INHBT.....	8-7
FIGURE 8-4: FLTA INHBT MODE AREAS.....	8-8
TABLE 8-2: FLTA SEARCH ENVELOPE FOR HTAWS	8-8
FIGURE 8-5: FLTA SEARCH VOLUME.....	8-11
FIGURE 8-6: POPUP MODE EXCESSIVE RATE OF DESCENT (GPWS MODE 1)	8-12
TABLE 8-3: HTAWS GPWS MODE 1 ENVELOPE.....	8-13
FIGURE 8-7: ROTORCRAFT GPWS MODE 1	8-13
TABLE 8-4: HTAWS GPWS MODE 2 ENVELOPES.....	8-14
TABLE 8-5: HTAWS GPWS MODE 2A ENVELOPES (NOT IN LANDING CONFIGURATION).....	8-14
TABLE 8-6: HTAWS GPWS MODE 2B ENVELOPES (LANDING CONFIGURATION).....	8-15
FIGURE 8-8: ROTORCRAFT GPWS MODE 2	8-15
FIGURE 8-9: ROTORCRAFT GPWS MODE 3	8-16
TABLE 8-7: HTAWS GPWS MODE 4 ENVELOPES.....	8-17
TABLE 8-8: HTAWS GPWS MODE 4A ENVELOPES	8-17
FIGURE 8-10: ROTORCRAFT GPWS MODE 4	8-18
TABLE 8-9: HTAWS GPWS MODE 5 ENVELOPES.....	8-19
FIGURE 8-11: ROTORCRAFT GPWS MODE 5	8-19
TABLE 8-10: EXTERNAL SENSORS AND SWITCHES (APPLICABLE TAWS SYSTEM)	8-21
TABLE 8-11: HTAWS BASIC PARAMETERS DETERMINATION.....	8-22
TABLE 8-12: TAWS AUTOMATIC INHIBIT FUNCTIONS	8-28
FIGURE 8-12: PFD SVS BASIC OPTION	8-31
FIGURE 8-13: PFD SVS TAWS OPTION.....	8-31
FIGURE 8-14: PFD SVS TAWS OPTION AND OBSTRUCTIONS	8-32
FIGURE 8-15: PFD OBSTRUCTION CAUTION	8-32
FIGURE 8-16: PFD OBSTRUCTION WARNING	8-33
FIGURE 8-17: AUTOMATIC PFD TERRAIN WARNING	8-33

8.1. Enhanced HTAWS and HTAWS (Terrain Awareness Warning System) Functions

The IDU provides TSO-C194 HTAWS functionality. Depending on aircraft configuration and external sensors/switches, the system is configurable as an Enhanced HTAWS or HTAWS. Functions provided by HTAWS are:

- 1) **Terrain Display:** Display of terrain and obstacles on PFD and ND.
- 2) **Forward Looking Terrain Awareness (FLTA):** Uses a terrain database and an obstruction database to alert the pilot to hazardous terrain or obstructions in front of the aircraft.
- 3) **Excessive Rate of Descent (GPWS Mode 1):** Alerts the pilot when the rate of descent is hazardously high as compared to height above terrain (i.e., descending into terrain).
- 4) **Excessive Closure Rate to Terrain (GPWS Mode 2):** Alerts the pilot when the rate of change of height above terrain is hazardously high as compared to height above terrain (i.e., flying level over rising terrain).
- 5) **Sink Rate after Takeoff or Missed Approach (GPWS Mode 3):** Alerts the pilot when a sink rate is detected immediately after takeoff or initiation of a missed approach.
- 6) **Flight into Terrain when not in Landing Configuration (GPWS Mode 4):** Alerts the pilot when descending into terrain without properly configuring the aircraft for landing.
- 7) **Excessive Downward Deviation from an ILS Glideslope (GPWS Mode 5):** Alerts the pilot when an excessive downward glideslope deviation is detected on the final approach segment of an ILS approach.

Table 8-1: TAWS Functions Provided by the EFIS

Aircraft Type	TAWS Class	Terrain Display	FLTA	GPWS Mode				
				1	2	3	4	5
Rotorcraft RG	Enhanced	✓	✓	✓	✓	✓	✓	✓
Rotorcraft FG	Enhanced	✓	✓	✓	✓	✓		✓
Rotorcraft	Normal	✓	✓			✓		

Notes: RG = Retractable Gear; FG = Fixed Gear

8.1.1. Terrain Display

The display of terrain on the PFD and MFD are described in Sections 3 Display Symbology and 5 Menu Functions and Step-By-Step Procedures of this pilot guide where applicable.



Figure 8-1: Terrain Display

8.2. Forward Looking Terrain Alert Function

The FLTA function uses the following information to alert the pilot to hazardous terrain or obstructions within a search envelope in front of the aircraft:

- 1) Terrain database
- 2) Obstruction database
- 3) Airport and Runway database

- | | |
|-------------------------|----------------------------|
| 4) Aircraft position | 7) Aircraft bank angle |
| 5) Aircraft track | 8) Aircraft altitude |
| 6) Aircraft groundspeed | 9) Aircraft vertical speed |



Other Rotorcraft

AW-109SP

Figure 8-2: FLTA INHBT

8.2.1. FLTA Modes

The EFIS FLTA mode is either slaved to the GPS/SBAS navigation mode or set automatically based upon default mode logic.

8.2.2. GPS/SBAS Navigation Mode Slaving

The EFIS performs TSO-C146c GPS/SBAS system functions in addition to the TAWS functions. As a result, GPS/SBAS navigation mode is available as an input to the TAWS. The pilot may select an IFR procedure (Approach, DP, or STAR) which automatically changes the GPS/SBAS navigation mode to Enroute, Terminal, Departure, or IFR Approach as appropriate. In addition, the EFIS allows the pilot to select a VFR approach to any runway or user waypoint with a defined approach path. Selection of a VFR approach causes automatic GPS/SBAS navigation mode changes to Enroute, Terminal, or VFR Approach as appropriate.

When slaved, the GPS/SBAS active runway threshold or user waypoint is the reference point for automatic FLTA inhibiting. The advantage is the GPS/SBAS navigation modes are a direct indication to the FLTA function of pilot intent.

8.2.3. Default FLTA Mode

If the default FLTA navigation mode is higher in precedence than the GPS/SBAS navigation mode, the FLTA mode is slaved to the default FLTA navigation mode.

These modes, in order of precedence, are as follows:

- 1) **Departure Mode:** This mode is enabled when in Ground Mode. The reference point for automatic FLTA inhibiting and mode envelope definition is the last point at which the ground definition was satisfied (this is near the liftoff point). The Departure Mode ends upon climbing through **1500 feet** above or traveling more than **6NM** from the reference point.

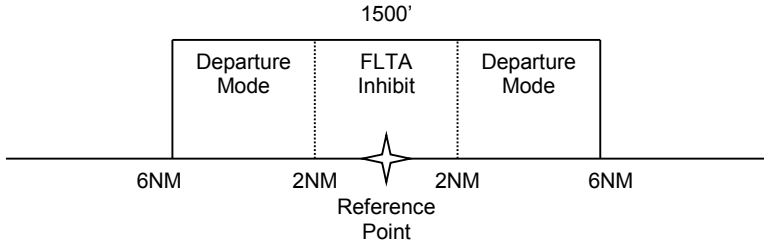


Figure 8-3: Default FLTA INHBT

- 2) **Other Modes:** For other default FLTA modes, the reference point for automatic FLTA inhibiting and mode envelope is the nearest runway threshold or the nearest user waypoint with a defined approach bearing. The TAWS system continuously searches all runway thresholds at the nearest three airports to determine the nearest runway threshold. The TAWS system performs a search for the nearest three airports and nearest user waypoints with a defined approach bearing every 3NM of distance traveled. Modes are as follows:
 - a) **Approach Mode:** Exists when within 1900 feet and 5NM of the reference point.
 - b) **Terminal Mode:** Exists from 5NM to 15NM from the reference point when below an altitude varying from 1900 feet (at 5NM) to 3500 feet (at 15NM) above the reference point.
 - c) **Enroute Mode:** Exists when not in any other mode.

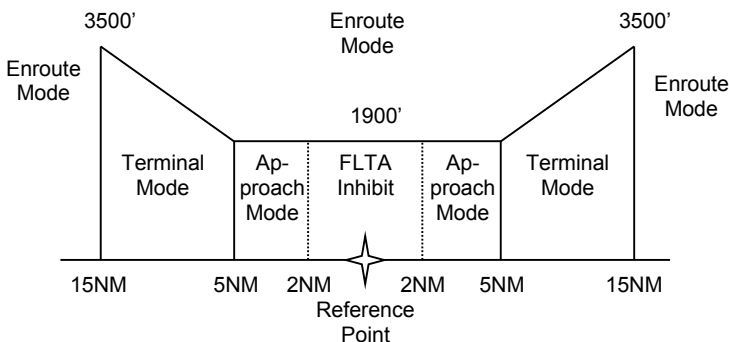


Figure 8-4: FLTA INHBT Mode Areas

8.3. FLTA Search Envelope

The FLTA search envelope is an area in front of and below the aircraft. If terrain or obstructions are found within the FLTA search envelope, a caution or warning is given to the pilot. The dimensions of the search envelope depend upon TAWS type, FLTA mode (described above), aircraft groundspeed, aircraft bank angle, and vertical speed. Basic envelope parameters are as follows.

TAWS Type: The TAWS type determines the value of several parameters used to calculate the search envelope. These parameters are described in Table 8-2.

Table 8-2: FLTA Search Envelope for HTAWS

Envelope	Parameter	Notes
Level-Off Rule	10% of vertical speed	Used for level off leading
Range	36 seconds of the forward range search envelope	Reduced to 24 seconds when Low Altitude Mode is engaged. The GPS/SBAS HFOM is added to range.
Enroute Mode Level/Climbing Flight RTC	150 feet	Reduced to 100 feet when Low Altitude Mode is engaged.

Table 8-2: FLTA Search Envelope for HTAWS

Envelope	Parameter	Notes
Terminal Mode Level/Climbing Flight RTC	150 feet	Reduced to 100 feet when Low Altitude Mode is engaged.
Approach Mode Level/Climbing Flight RTC	150 feet	Reduced to 100 feet when Low Altitude Mode is engaged.
Departure Mode Level/Climbing Flight RTC	100 feet	
Enroute Mode Descending RTC	100 feet	
Terminal Mode Descending RTC	100 feet	
Approach Mode Descending RTC	100 feet	
Departure Mode Descending RTC	100 feet	

- 1) **Aircraft Track:** The terrain search envelope is aligned with aircraft track.
- 2) **Aircraft Groundspeed:** Aircraft groundspeed is used in conjunction with the range parameter to determine the look-ahead distance. In addition, aircraft groundspeed is used in conjunction with FLTA mode to determine the search volume width as follows:
 - a) **Enroute Mode:** Search volume width is based upon a 30° change in track followed by 30 seconds of flight at aircraft groundspeed. Maximum width is 0.5NM either side of track.
 - b) **Terminal Mode:** Search volume width is based upon a 15° change in track followed by 30 seconds of flight at aircraft groundspeed. Maximum width is 0.5NM either side of track.
 - c) **Approach Mode:** Search volume width is based upon a 10° change in track followed by 30 seconds of flight at aircraft groundspeed. Maximum width is 0.3NM either side of track.

- d) **Departure Mode:** Search volume width is based upon a 10° change in track followed by 30 seconds of flight at aircraft groundspeed. Maximum width is 0.3NM either side of track.

After calculating search volume width as described above, the GPS/SBAS HFOM is added to search volume width.

- 1) **Aircraft Bank Angle:** Used to expand the search volume in the direction of a turn and requires at least 10° of bank. In addition, search volume expansion is delayed so at 10° of bank, the bank angle must be continuously held for 3.25 seconds. The amount of delay is reduced linearly with increased bank angle so at 30° of bank there is no delay time. Delaying is intended to reduce nuisance search volume expansions when experiencing bank angle excursions due to turbulence.
- 2) **Aircraft Vertical Speed:** Used to determine which RTC values should be used. At vertical speeds above -500 fpm, level and climbing flight RTC values are used. At vertical speeds less than or equal to -500 fpm, descending flight RTC values are used. In addition, vertical speed is used to increase the descending flight RTC value used by the system. The increase in descending flight RTC is based upon a three-second pilot reaction time and VSI leading according to the level-off rule parameter.

8.3.1. FLTA Search Volume

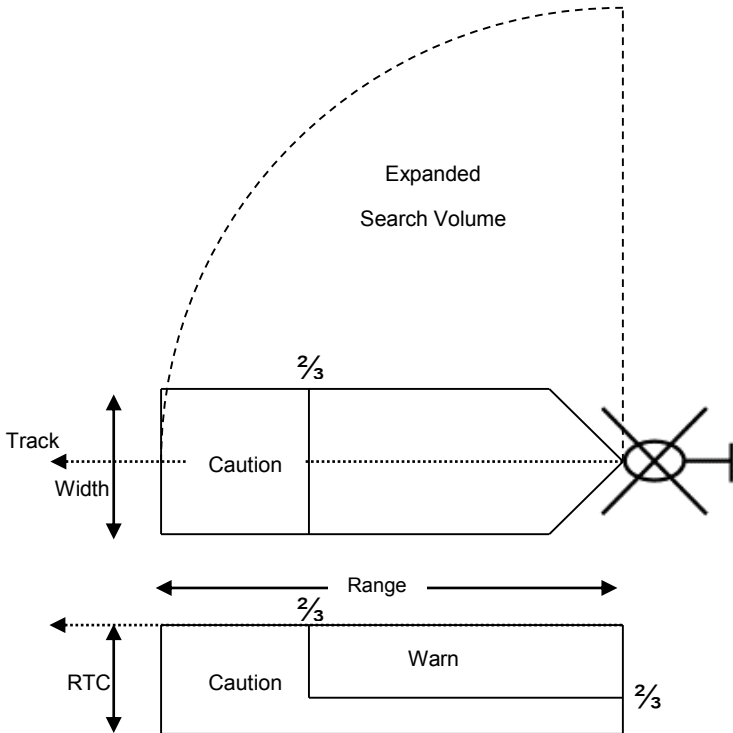


Figure 8-5: FLTA Search Volume

8.3.2. FLTA Alerts and Automatic Popup

When terrain or obstructions fall within the FLTA search envelope, a FLTA warning is generated. Terrain rendering is enabled when a FLTA warning is initiated or upgraded as follows:

- 1) On PFD screen, terrain rendering is enabled;
- 2) On navigation display screen, terrain rendering is enabled only if TAWS Inhibit is not enabled (i.e., TAWS Inhibit prevents terrain from being automatically enabled on the navigation display).

In addition, when an FLTA warning is initiated or upgraded, an automatic popup mode is engaged as follows:

- 1) Display switched to navigation display.
- 2) Display switched to aircraft centered and heading up.
- 3) Display panning disabled.
- 4) Display scale set to:
 - a) 10NM (groundspeed > 200 knots);
 - b) 5 NM (groundspeed < = 200 knots and groundspeed > 100 knots); or
 - c) 2NM (groundspeed < = 100 knots).

After the popup mode is engaged, the pilot may change any setting automatically changed by the popup mode. In addition, **RESET** appears for 20 seconds to allow the pilot to reset the previous screen configuration with one button press. Popups only occur on IDU #0 or IDU #2 (with Enhanced HTAWS enabled) and do not occur if TAWS Inhibit is enabled.

NOTE:

Function is present in rotorcraft Enhanced HTAWS systems only.

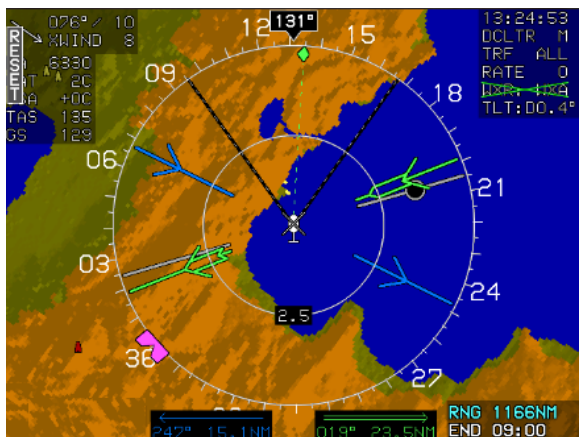


Figure 8-6: Popup Mode Excessive Rate of Descent (GPWS Mode 1)

The GPWS Mode 1 function uses aircraft vertical speed information and AGL altitude to alert the pilot when the rate of descent is hazardously high as compared to height above terrain. GPWS Mode 1 has a caution and warning threshold. When below the thresholds, a GPWS Mode 1 warning is generated. The curve is shown in Figure 8-7.

Table 8-3: HTAWS GPWS Mode 1 Envelope

Sink Rate (fpm)	AGL Altitude (ft.)	
	“Sink Rate” Caution Threshold	“Pull Up” Warning Threshold
< 1000	$62.5\% \times (\text{Sink Rate} - 600)$	$66\% \times (\text{Caution Threshold})$
1000 to 3000	Lesser of: 750, or, $25\% \times (\text{Sink Rate})$	

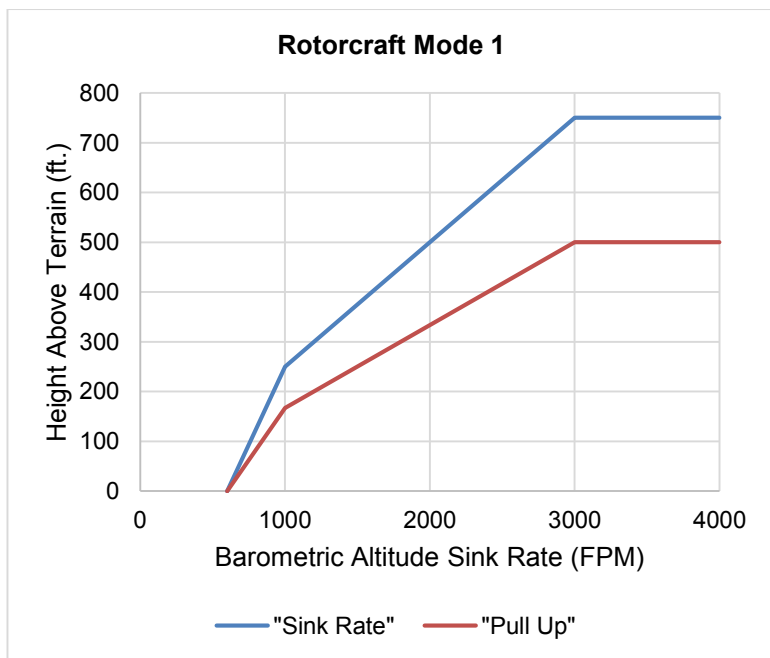


Figure 8-7: Rotorcraft GPWS Mode 1

8.4. Excessive Closure Rate to Terrain (GPWS Mode 2)

This function is present in Enhanced HTAWS system only. The GPWS Mode 2 function uses filtered AGL rate and AGL altitude to alert the pilot when the rate of change of height above terrain is hazardously high as compared to height above terrain (i.e., flying level over rising terrain). AGL rate filtering is based upon a 10-second sampling time.

There are two Mode 2 envelopes: Mode 2A, which is active when not in landing configuration, and Mode 2B, which is active when in landing configuration. Envelope selection is determined as follows.

Table 8-4: HTAWS GPWS Mode 2 Envelopes

Table 8-4: HTAWS GPWS Mode 2 Envelopes		
Landing Gear	Mode 2A	Mode 2B
Retractable	Landing Gear Up	Landing Gear Down
Fixed	AGL Altitude > 200 ft or Airspeed > 80 KIAS	AGL Altitude ≤ 200 ft and Airspeed ≤ 80 KIAS

When the GPWS Mode 2 envelope is pierced, a GPWS Mode 2 warning is generated.

Table 8-5: HTAWS GPWS Mode 2A Envelopes (NOT in Landing Configuration)

AGL Rate (fpm)	AGL Altitude (ft.)	
	“Caution, Terrain” Caution Threshold	“Pull Up” Warning Threshold
< 1905	$125\% \times (\text{AGL Rate} - 1600)$	
> 1905	20% of the lesser of:	
	Airspeed (KIAS)	AGL Rate (fpm)
	< 90	3120
	90 to 130	$3120 + 72 \times (\text{Airspeed} - 90)$
	> 130	6000
	or AGL Rate	
		$66\% \times (\text{Caution Threshold})$

Table 8-6: HTAWS GPWS Mode 2B Envelopes (Landing Configuration)

AGL Altitude (ft.)	
“Caution, Terrain” Caution Threshold	“Pull Up” Warning Threshold
Lesser of: 300, or, $20\% \times (\text{AGL Rate} - 2000)$	$66\% \times (\text{Caution Threshold})$

Envelope Depictions Mode 2 envelopes are shown in Figure 8-8.

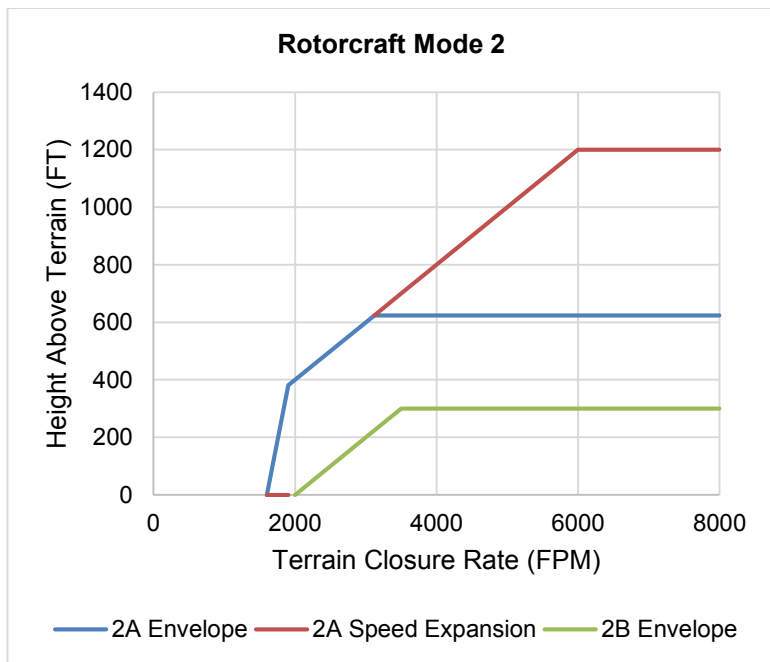


Figure 8-8: Rotorcraft GPWS Mode 2

8.5. Sink Rate after Takeoff or Missed Approach (GPWS Mode 3)

The GPWS Mode 3 function uses aircraft vertical speed information and AGL altitude to alert the pilot when a sink rate is detected immediately after takeoff or initiation of a missed approach.

GPWS Mode 3 is armed by either being in ground mode or by being on the first leg of a missed approach procedure (as determined by the GPS/SBAS) with distance to the active runway threshold increasing. GPWS Mode 3 is disarmed upon climbing through **700 feet AGL**, traveling more than **6 NM** from the last point at which the ground definition was satisfied (this is near the liftoff point), or transitioning to the second leg of a missed approach procedure. GPWS Mode 3 has a caution threshold based upon height above terrain and vertical speed. When below the caution threshold, a GPWS Mode 3 warning is generated as defined in Figure 8-9.

“Don’t Sink” AGL = 140 % of sink rate

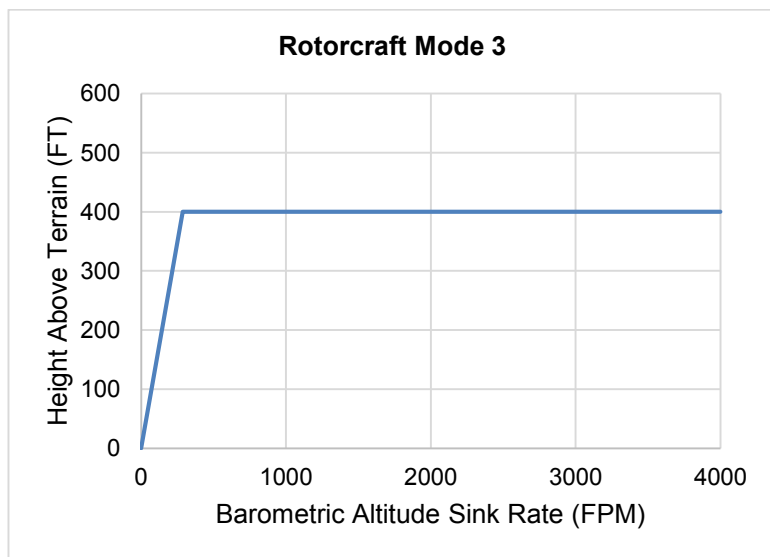


Figure 8-9: Rotorcraft GPWS Mode 3

8.6. Flight into Terrain when not in Landing Configuration (GPWS Mode 4)

This function is present in Enhanced HTAWS systems. The GPWS Mode 4 function uses aircraft speed information and AGL altitude to alert the pilot when descending into terrain without properly configuring the aircraft for landing. There are two Mode 4 envelopes: Mode 4A, which gives cautions when landing gear is in other than landing configuration, and Mode 4B, which gives cautions when landing gear or flaps are in other than landing configuration. Applicability of Mode 4 envelopes to aircraft types are as follows.

Table 8-7: HTAWS GPWS Mode 4 Envelopes

Landing Gear	Mode 4A	Mode 4B
Retractable	Landing Gear Up	Not Applicable
Fixed	Not Applicable	Not Applicable

The rotorcraft Mode 4 envelope consists of a low-speed region and a high-speed region. In the low-speed region, **TOO LOW** is presented in conjunction with a single “Too Low Gear” aural alert. In the high-speed region, **TOO LOW** is presented in conjunction with a single “Too Low Terrain” aural alert. In addition, the rotorcraft Mode 4 has autorotation expansion and, when engaged, the aural alert is “Too Low Gear” regardless of speed.

Mode 4 alerting criteria require the Mode 4 envelope to be entered from above so changing aircraft configuration while within a Mode 4 envelope does not generate an alert.

Table 8-8: HTAWS GPWS Mode 4A Envelopes

Segment	Speed (KIAS)	AGL Altitude (ft.)
4A Low-Speed	< 100	150
4A High-Speed	≥ 100	(400 in autorotation)

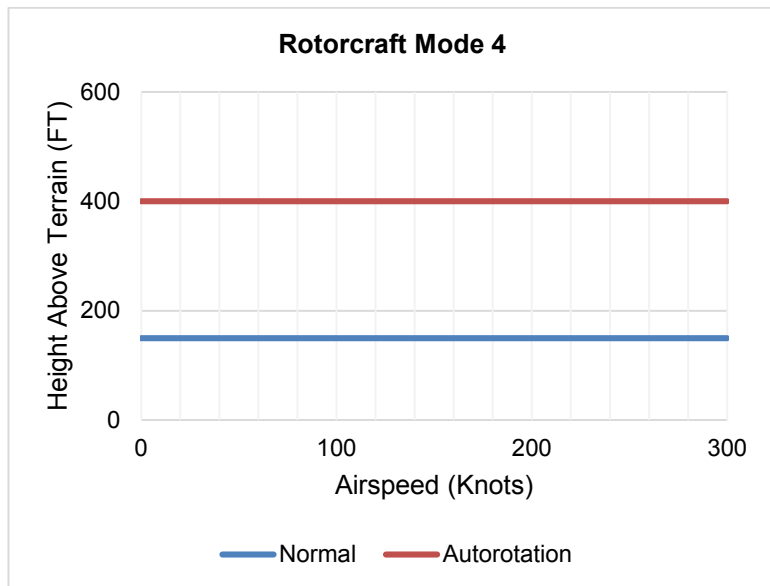


Figure 8-10: Rotorcraft GPWS Mode 4

8.7. Excessive Downward Deviation from an ILS Glideslope (GPWS Mode 5)

This function is present in Enhanced HTAWS systems only. The GPWS Mode 5 function uses ILS glideslope deviation information and AGL altitude to alert the pilot when an excessive downward glideslope deviation is detected on the final approach segment of an ILS approach. GPWS Mode 5 is armed when a valid glideslope signal is being received AND the aircraft is below **1000' AGL**.

GPWS Mode 5 has a caution and warning threshold. When below a threshold, a GPWS Mode 5 warning is generated. The curve compares glideslope deviation to AGL altitude as shown in Figure 8-11.

Table 8-9: HTAWS GPWS Mode 5 Envelopes

Caution Threshold	Warning Threshold
Greater of: $\left[1.3 + 1.4\% \times (150 - \text{AGL Altitude}) \right] \text{ Dots}$ or 1.3 Dots	Greater of: $\left[2 + 1\% \times (150 - \text{AGL Altitude}) \right] \text{ Dots}$ or 2 Dots

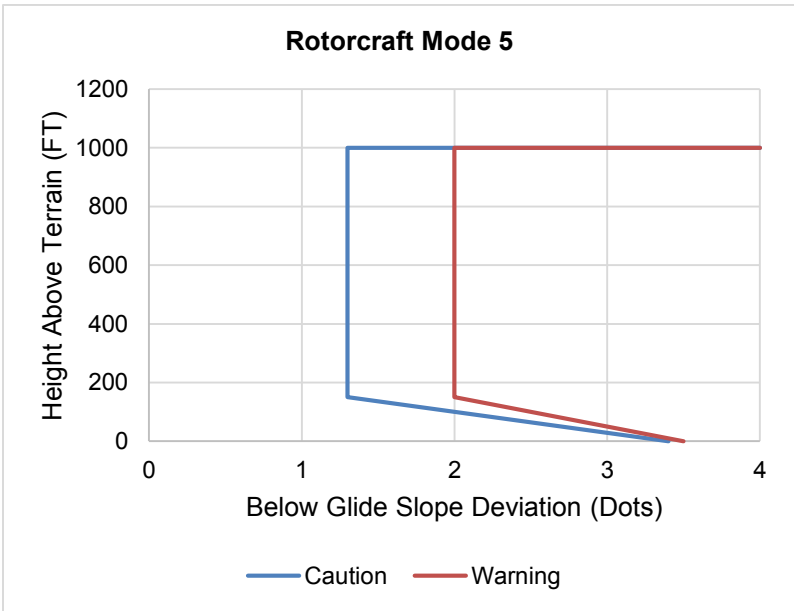


Figure 8-11: Rotorcraft GPWS Mode 5

8.8. External Sensors and Switches

The EFIS TAWS system requires a variety of inputs from external sensors and switches to perform its functions. These inputs are as follows:

- 1) **GPS/SBAS Receiver:** Source of aircraft position, geodetic height, horizontal figure of merit (HFOM), vertical figure of merit (VFOM), loss of integrity (LOI), and loss of navigation (LON) inputs for the TAWS. The GPS/SBAS receiver connects directly to the EFIS IDU.
- 2) **Air Data Computer (ADC):** Source of barometric altitude, outside air temperature, and vertical speed for the TAWS and connects directly to the EFIS IDU.
- 3) **ILS Receiver:** A glideslope receiver is the source of glideslope deviation for the TAWS.
- 4) **Radar Altimeter (RA):** Source for radar altitude for the TAWS.
- 5) **Gear Position Sensors:** Landing gear position discrettes, as configured in the system limits, are the source of landing gear position for the TAWS.
- 6) **Flap Position Sensor:** A flap position discrete, as configured in the system limits is the source of flap position for the TAWS.
- 7) **TAWS Inhibit Switch:** As configured in the system limits, used for manual inhibiting of TAWS alerting functions. The TAWS Inhibit Switch is of the latching type and gives an obvious indication of actuation (e.g., toggle/rocker or pushbutton with indicator light and **TAWS INHBT** on the lower left corner of the PFD).
- 8) **Low Altitude Mode Switch:** As configured in the system limits, used for inhibiting and modifying HTAWS alerting functions to allow normal operation at low altitudes. The Low Altitude Mode Switch is of the latching type and gives an obvious indication of actuation (e.g., toggle/rocker or pushbutton with indicator light and **TAWS LOW ALT** on the lower left corner of the PFD).
- 9) **Audio Mute Switch:** Used for silencing active aural alerts. The Audio Mute Switch is of the momentary type and is connected directly to the EFIS IDU. The Audio Mute Switch is momentarily activated when silencing of active aural alerts is desired.

- 10) **Glideslope Deactivate Switch:** As configured in the system limits, used for inhibiting the GPWS Mode 5 function. The Glideslope Deactivate Switch is of the momentary type and is momentarily activated when inhibition of the GPWS Mode 5 function is desired.

Applicability of external sensors and switches for the applicable TAWS system is as follows.

Table 8-10: External Sensors and Switches (Applicable TAWS System)

Aircraft Type	Rotorcraft RG	Rotorcraft FG	Rotorcraft
HTAWS Class	Enhanced	Enhanced	Normal
GPS/SBAS	✓	✓	✓
ADC	✓	✓	✓
Gear Position Sensor	✓		
TAWS Inhibit Switch	✓	✓	✓
Audio Cancel Switch	✓	✓	✓
Low Altitude Mode Switch	✓	✓	✓
Low Torque Sensor	✓	✓	
ILS	✓	✓	
Radar Altimeter	✓	✓	
Glideslope Deactivate Switch	✓	✓	

Notes: RG = Retractable Gear; FG = Fixed Gear

8.9. TAWS System Basic Parameter Determination

The fundamental parameters used for TAWS system functions are.

Table 8-11: HTAWS Basic Parameters Determination

Parameter	Source	Notes
Aircraft position, groundspeed and track	GPS/SBAS	HFOM must be less than or equal to the greater of 0.3 NM or the Horizontal alert limit (HAL) for the mode of flight.
MSL Altitude	GPS/SBAS	<p>Geodetic Height converted to MSL with the current EGM (Earth Gravity Model) database. In order for this to be considered valid for use as MSL altitude, the VFOM must be less than or equal to 106 feet.</p> <p>The secondary source of MSL altitude is barometric altitude from an air data computer. Barometric altitude is determined based upon a barometric setting in the following order of preference:</p> <ol style="list-style-type: none"> 1) If either the pilot or co-pilot system is operating in QNH mode, the QNH barometric setting is used (on-side barometric setting preferred); or 2) If GPS/SBAS geodetic height has been valid within the last 30 minutes, a

Table 8-11: HTAWS Basic Parameters Determination

Parameter	Source	Notes
		<p>barometric setting derived from the GPS/SBAS geodetic height is used.</p> <p>If neither of the above conditions is met, MSL altitude is marked as invalid.</p> <p>When a reporting station elevation is determined and outside air temperature is valid, a temperature correction is applied.</p> <p>TAWS uses the lower of the barometric altitude or the temperature-corrected altitude. In the case of QNH-mode barometric setting, reporting station elevation is derived from waypoint or active runway elevations in the active flight plan using the following logic:</p> <ol style="list-style-type: none"> 1) If the aircraft is in TERMINAL, DEPARTURE, IFR APPROACH, or VFR APPROACH mode and an active runway exists, reporting station elevation is the elevation of the

Table 8-11: HTAWS Basic Parameters Determination

Parameter	Source	Notes
		<p>active runway threshold.</p> <p>2) Otherwise, if the aircraft is in TERMINAL mode, reporting station elevation is the elevation of the airport causing TERMINAL mode.</p> <p>3) In ENROUTE mode, no reporting station elevation is determined.</p> <p>In the case of GPS/SBAS geodetic height-based barometric setting, reporting station elevation is the GPS MSL altitude reported at the time the barometric setting was determined. The following definitions:</p> <p>QFE: Barometric setting resulting in the altimeter displaying height above a reference elevation (e.g., airport or runway threshold).</p> <p>QNE: Standard barometric setting (29.92 inHg or 1013 mbar) used to display pressure altitude for flight above the transition altitude.</p>

Table 8-11: HTAWS Basic Parameters Determination

Parameter	Source	Notes
		<p>QNH: Barometric setting resulting in the altimeter displaying altitude above mean sea level at the reporting station.</p>
Terrain Data	Terrain Database	<p>To be considered valid for use, the following conditions must apply:</p> <ol style="list-style-type: none"> 1) Aircraft position is valid; 2) Aircraft position is within the boundaries of the terrain database; and 3) Terrain database is not corrupt as determined by CRC-32 checks at system initialization and during runtime.
Obstacle Data	Obstacle Database	<p>To be considered valid for use, the following conditions must apply:</p> <ol style="list-style-type: none"> 1) Aircraft position is valid; 2) Aircraft position is within the boundaries of the obstacle database; and 3) Obstacle database is not corrupt as determined by CRC-32 checks at system initialization.

Table 8-11: HTAWS Basic Parameters Determination

Parameter	Source	Notes
AGL Altitude	Radar Altitude	Secondary source for AGL Altitude is MSL altitude less terrain altitude.
Vertical Speed	Instantaneous vertical speed	IVSI values come from barometric vertical speed from an ADC “quickened” with vertical acceleration from an AHRS. The secondary source for vertical speed is barometric vertical speed from an ADC. The tertiary source for vertical speed is GPS/SBAS vertical speed providing the VFOM is less than or equal to 106 feet.
Terrain Closure Rate	The smoothed first derivative of AGL Altitude	Due to the multiple sources for altitude, there are multiple sources for terrain closure rate.
Runway/Reference point location	EFIS navigation database	To be considered valid for use, the following conditions must apply: <ol style="list-style-type: none"> 1) Aircraft position is valid; 2) Aircraft position is within the boundaries of the navigation database; and 3) Navigation database is not corrupt as determined by a CRC-32 check at system initialization.

8.10. TAWS Automatic Inhibit Functions (Normal Operation)

The following automatic inhibit functions occur during normal TAWS operation to prevent nuisance warnings:

- 8) **FLTA function** is automatically inhibited when in the Terminal, Departure, IFR Approach, or VFR Approach Modes and within 2 NM and 1900' of the reference point.
- 9) **GPWS Modes 1 through 4** are automatically inhibited when below 50 feet AGL (radar altimeter AGL altitude) or below 100 feet AGL (terrain database AGL altitude).
- 10) **GPWS Mode 4** is inhibited while Mode 3 is armed.
- 11) **GPWS Mode 5** is inhibited below 200' AGL. This form of automatic inhibit remains active until the aircraft climbs above 1000' AGL. The purpose of this form of inhibiting is to prevent nuisance alarms on missed approach when glideslope sidelobes are detected by the glideslope receiver.
- 12) **FLTA function** is automatically inhibited when airspeed or groundspeed is below the HTAWS FLTA Inhibit Speed.

8.10.1. TAWS Automatic Inhibit Functions (Abnormal Operation)

The following automatic inhibit functions occur during the specified abnormal operations:

- 1) **Autorotation detection:** When the low torque sensor is active, an Enhanced HTAWS system enters Autorotation Mode. In this mode:
 - a) FLTA is inhibited;
 - b) GPWS Mode 1 is inhibited;
 - c) GPWS Mode 2 is inhibited; and
 - d) GPWS Mode 4 uses a modified envelope (see § 8.6).
- 2) **System Sensor/Database Failures:** System sensor failures, non-installation of optional sensors, database failures, and combinations thereof affect the TAWS system as follows.

Table 8-12: TAWS Automatic Inhibit Functions								
Sensor	Parameters Lost	Terrain Displaced	FLTA	GPWS Mode				
				1	2	3	4	5
GPS/SBAS (H)	AC Position	Inhibit	Inhibit					
TD	Terrain Elev.	Inhibit	Inhibit					
ILS	Glide-slope Dev.							Inhibit
MSL	MSL Altitude	Inhibit	Inhibit					
GPS/SBAS (H) + RADLT	AC Position, AGL Altitude	Inhibit	Inhibit	Inhibit	Inhibit	Inhibit	Inhibit	Inhibit
GPS/SBAS (V) + ADC	MSL Altitude, VSI	Inhibit	Inhibit	Inhibit		Inhibit		
TD + RADLT	Terrain Elev. AGL Altitude	Inhibit	Inhibit	Inhibit	Inhibit	Inhibit	Inhibit	Inhibit

Table 8-12: TAWS Automatic Inhibit Functions									
Sensor	Parameters Lost	Terrain Displaced	FLTA	GPWS Mode					
				1	2	3	4	5	
MSL + RADLT	MSL Altitude, AGL Altitude	Inhibit	Inhibit	Inhibit	Inhibit	Inhibit	Inhibit	Inhibit	Inhibit
GPS/SBAS (V) + ADC + RADLT	MSL Altitude, VSI, AGL ALT	Inhibit	Inhibit	Inhibit	Inhibit	Inhibit	Inhibit	Inhibit	Inhibit

Notes:

- 1) The combinations listed give the minimum combinations with the worst consequences. Many other combinations are possible, but their effects are subsumed within the combinations listed.
- 2) GPS/SBAS (H) = HFOM > max (0.3NM, HAL). Indication is loss of terrain display on PFD and ND.
- 3) GPS/SBAS (V) = VFOM > 106'.
- 4) GPS/SBAS = GPS/SBAS (H) + GPS/SBAS (V). Indication is loss of terrain display on PFD and ND.
- 5) TD = Terrain Data invalid due to being beyond the database boundaries or database corruption.
- 6) ADC = Air Data Computer. Indication is **ADC1 FAIL** / **ADC2 FAIL** flags or in case of a single ADC installation red X's appear over Airspeed and Altimeter tapes.

- 7) RADALT = Radar Altimeter. Indication is lack of radar altimeter source indication on radar altimeter display.
- 8) ILS = ILS Glideslope Deviation. Indication is lack of glideslope needles.
- 9) MSL=MSL Altitude Invalid. Indication is NO TAWS in the absence of other failures.

8.10.2. TAWS Manual Inhibit Functions

The pilot may select the following manual inhibit functions:

- 1) **Terrain Display** function may be inhibited using an EFIS soft menu declutter control.
- 2) **All TAWS** alerting functions (including popup functionality) are manually inhibited by actuation of the external TAWS Inhibit Switch. The Terrain Display function, including display of FLTA warning (red) and caution (amber [yellow]) flags on the ND, is not affected by the TAWS Inhibit Switch.
- 3) **GPWS Mode 5** is manually inhibited by actuation of the momentary Glideslope Cancel Switch when below 1000' AGL. GPWS Mode 5 manual inhibit automatically resets by ascending above 1000' AGL.

8.11. TAWS Selections on PFD

The PFD Declutter menu includes three option possibilities for TAWS as follows:

- 1) SVS TAWS
- 2) SVS BASIC
- 3) None

The following figures show all possible scenarios including “None” where the aircraft pierces the TAWS FLTA Terrain envelope, and SVS TAWS automatically becomes enabled for the safest possible Warning Alert condition.

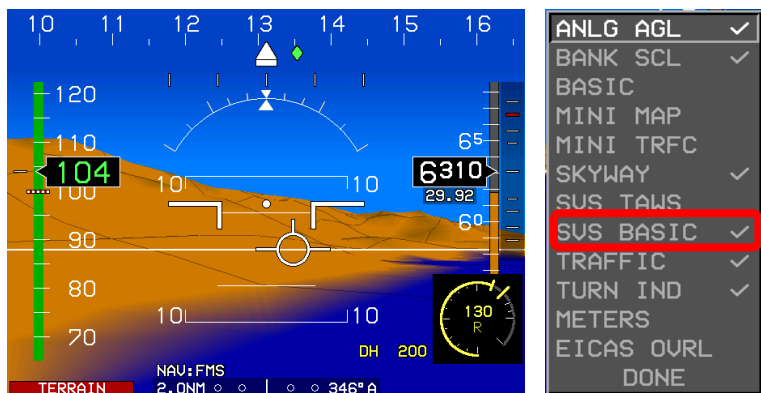
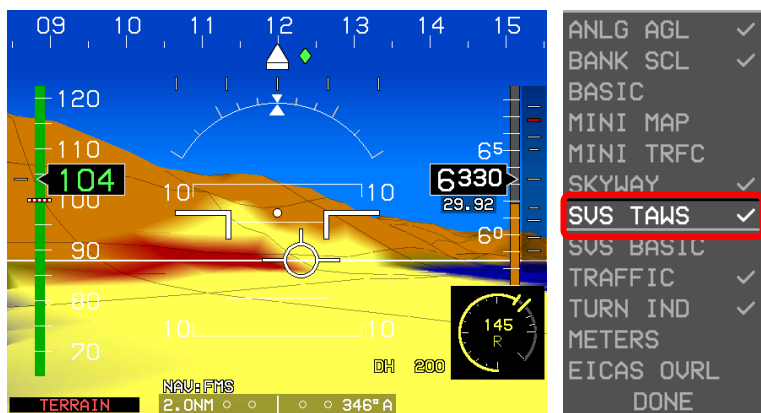


Figure 8-12: PFD SVS BASIC Option



TAWS FLTA Caution Terrain: Amber (Yellow)
TAWS FLTA Caution Warning: Red

Figure 8-13: PFD SVS TAWS Option

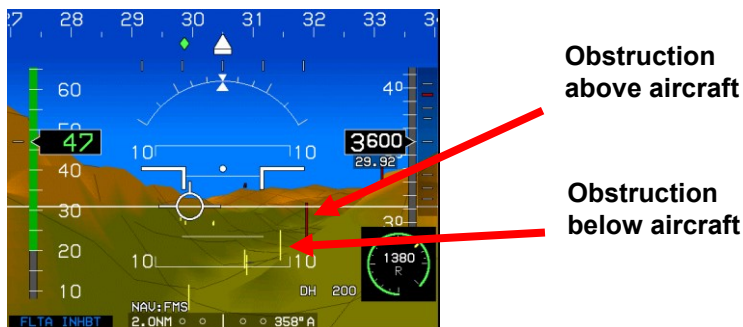


Figure 8-14: PFD SVS TAWS Option and Obstructions



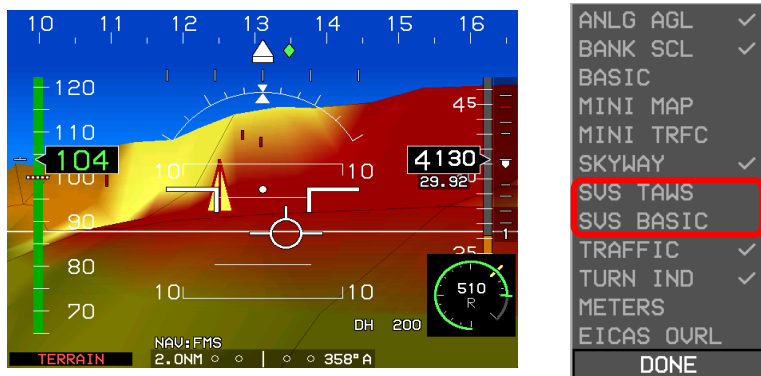
Obstruction within TAWS FLTA caution envelope with aural annunciation “Caution Obstruction, Caution Obstruction”. The obstruction symbols flash.

Figure 8-15: PFD Obstruction Caution



Obstruction within TAWS FLTA warning envelope with aural annunciation “Warning Obstruction, Warning Obstruction”. The obstruction symbols flash.

Figure 8-16: PFD Obstruction Warning



If SVS TAWS and SVS BASIC were not checked and the aircraft pierced the TAWS FLTA Terrain envelope, the EFIS automatically enables SVS TAWS. **TERRAIN** takes precedence over **OBSTRUCTION**.

Figure 8-17: Automatic PFD Terrain Warning

Section 9 Appendix

Table of Contents

SECTION 9	APPENDIX	9-1
9.1.	APPENDIX	9-5
9.2.	OPERATING TIPS	9-5
9.3.	DOMESTIC OR INTERNATIONAL FLIGHT PLANNING	9-5
9.4.	DESCENT PLANNING	9-5
9.4.1.	<i>Terrain Clearance</i>	9-5
9.4.2.	<i>Departure Airport Information</i>	9-6
9.4.3.	<i>Unique Names for Flight Plans</i>	9-6
9.4.4.	<i>Altimeter Settings</i>	9-6
9.4.5.	<i>Warnings, Cautions, and Advisories</i>	9-6
9.5.	MAGNETIC VS. TRUE NORTH MODES OF OPERATION	9-7
9.6.	ALTITUDE MISCOMPARE THRESHOLD	9-8
9.7.	AIRSPPEED MISCOMPARE THRESHOLD	9-9
9.8.	JEPPESEN NAVDATA CHART COMPATIBILITY	9-11
9.9.	ARINC 424 PATH-TERMINATOR LEG TYPES	9-12
9.10.	DATA LOGGING AND RETRIEVAL	9-18
9.11.	LOG FILES	9-18
9.11.1.	<i>Delete LOG Files</i>	9-18
9.12.	ROUTES AND WAYPOINTS	9-18
9.12.1.	<i>VFR Flight Planning</i>	9-18
9.12.2.	<i>Download Routes and User Waypoints</i>	9-19
9.13.	EFIS TRAINING TOOL (ETT)	9-19
9.14.	UPLOAD ROUTES AND USER WAYPOINTS	9-19
9.14.1.	<i>Delete Routes</i>	9-20
9.15.	USB EXTERNAL DRIVE MEMORY LIMITATIONS	9-20

9.16.	SERVICE DIFFICULTY REPORT.....	9-21
9.17.	CERTIFICATION BASIS.....	9-22
9.18.	ENVIRONMENTAL REQUIREMENTS	9-24

List of Figures and Tables

FIGURE 9-1: US/UK WORLD MAGNETIC MODEL	9-7
TABLE 9-1: ALLOWABLE INSTRUMENT ERROR	9-8
TABLE 9-2: REGULATORY REFERENCE	9-9
TABLE 9-3: AIRSPEED ERROR	9-10
TABLE 9-4: AIRSPEED REGULATORY REFERENCE	9-10
TABLE 9-5: PATH TERMINATORS	9-12
FIGURE 9-2: VFR WAYPOINT	9-19

9.1. Appendix

The appendix of this pilot guide contains a variety of useful information not found elsewhere in the document including operating tips, system specifications, and feedback forms.

9.2. Operating Tips

With the Genesys Aerosystems EFIS installed and certified in all categories of certified aircraft, numerous tips and suggestions are available for obtaining the maximum performance and benefit from this system. Additional operating tips become available with future releases of this publication.

9.3. Domestic or International Flight Planning

Due to the differences in every aircraft avionics suite installation, it is up to the pilot to determine what equipment code is applicable for domestic or international flight plans. It is solely up to the aircraft operator to determine what certifications pertain to them. All certifications are outlined in the Airplane or Rotorcraft Flight Manual Supplement. Helpful FAA links for this information may be found at:

http://www.faa.gov/about/office_org/headquarters_offices/ato/service_units/air_traffic_services/flight_plan_filing/

9.4. Descent Planning

Instead of performing conventional time/speed/distance/descent-rate calculations, use the waypoint symbol for descent planning. Simply maintain the cruise altitude until the "X" at the bottom of the waypoint symbol is 2-3 degrees below the horizon (as indicated by the pitch scale) then begin a 2-3 degree descent. Maintain the correct descent angle by keeping the flight path marker positioned on the waypoint "X" symbol. Following the skyway boxes assures the VNAV descent angle is maintained.

9.4.1. Terrain Clearance

Use the flight path marker to evaluate climb performance in regards to terrain clearance. If climbing at the best climb speed to clear terrain and the flight path marker is overlaying the terrain which must be cleared, the climb rate is insufficient. Either the course or climb rate must be altered to adequately clear the terrain. If the flight path marker is well clear of the terrain (overlying blue), the climb is

sufficient for the present time, and no further action is necessary until level-off.

9.4.2. Departure Airport Information

On startup, all information for the departure airport is readily available. The altimeter is automatically set to the nearest IFR runway touchdown zone elevation. Press **NRST (R3)** to reveal the nearest airports, when highlighted where all important data such as frequencies are displayed.

9.4.3. Unique Names for Flight Plans

Multiple routes between the same airport pairs are numbered automatically (KCEW-KDHN) [0], (KCEW-KDHN) [1], etc.). With some ingenuity, pilots may work around this and apply easily remembered differentiation. If a route is routinely flown from one airport to another, but different routing becomes necessary due to MOA areas being hot or weather, etc., two or more different flight plans may be created for the same destination.

Create two different user waypoints at the departure airport named KCEWN and KCEWS as an example for departing Sikes on a northern routing (KCEWN) or a southern routing (KCEWS) followed by the different routing to clear the MOA or whatever creates the necessity for specific routing.

9.4.4. Altimeter Settings

Use caution when setting the altimeter and inadvertently changing the transition level. If this is reset to a lower than normal altitude, **CHK BARO** may appear due to the altimeter setting not set on 29.92 inHg or 1013 mbar.

9.4.5. Warnings, Cautions, and Advisories

Review all conditions found in the Section 2 System Overview for Warnings, Cautions, and Advisories. These conditions precisely define the scenario for the various warnings, cautions, and advisory flags as they appear including the time delay where appropriate and any time delay when applicable.

9.5. Magnetic vs. True North Modes of Operation

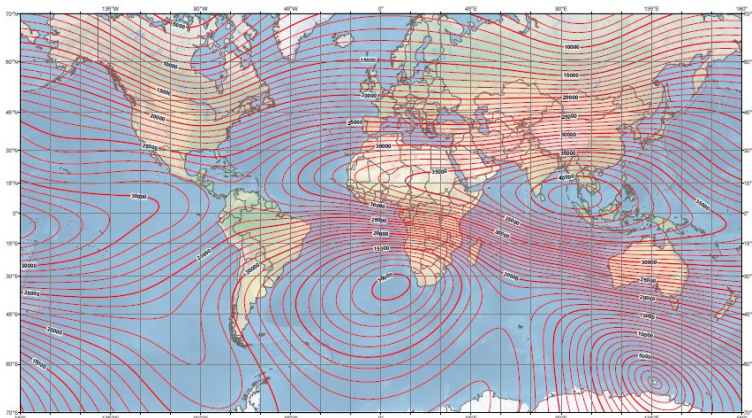


Figure 9-1: US/UK World Magnetic Model

There are two modes for the ADAHRS:

- 1) Slaved mode (i.e., compass rose stabilized by the Earth's magnetic flux horizontal field) is the normal mode. It works well over most of the surface of the Earth (i.e., areas with a horizontal field of 5000nT or above, which includes about 2/3^{ds} of Canadian NDA, see Figure 9-1). The ADAHRS senses magnetic flux with a 3-D magnetometer. Performance in small horizontal fields is installation dependent as variable magnetic disturbances from the aircraft may begin to predominate.
- 2) Free or "DG" mode (i.e., compass rose not stabilized by the Earth's magnetic flux horizontal field and subject to drift) is used in areas of magnetic disturbances (oil rigs, MRI machines, etc.) or in areas where the horizontal field is too weak. In Free/"DG" mode, heading no longer corrects towards the Earth's magnetic flux horizontal field, and the heading solution may be "slewed" by the pilot.

There are two modes for the EFIS:

- 1) Magnetic North mode: In this mode, the heading from the AHRS (whether slaved or Free/"DG") is used as-is and is expected to reflect Magnetic North. GPS Track is converted from True North-referenced to Magnetic North-referenced using a

magnetic variation database. The PFD scenes and compass-rose symbols are aligned with Magnetic North and wind is displayed referenced to Magnetic North.

- 2) True North mode: In this mode, GPS Track is used as-is and reflects True North. When the AHRS is in Slaved mode, the heading from the AHRS is converted from Magnetic North-referenced to True North-referenced using a magnetic variation database. When the AHRS is in Free/"DG" mode, the heading from the AHRS is used as-is and is expected to reflect True North. The PFD scenes and compass-rose symbols are aligned with True North and wind is displayed referenced to True North.

NOTE:

Designating Magnetic North vs. True North mode is critical since it determines how the inputs are used, i.e. the relationship between GPS Track and ADAHRS Heading. Mixing things up in Free/"DG" mode (i.e. slewing the compass rose to match Magnetic North when in True North mode and vice-versa) may result in large errors in wind calculations and GPS track/flight path marker displays.

9.6. Altitude Miscompare Threshold

The altitude miscompare threshold is based upon the allowable altitude error. There are two components to allowable altitude error, instrument error and installed system error. Allowable instrument error is based upon the values of SAE AS8002A as follows.

Table 9-1: Allowable Instrument Error	
Altitude	Allowed Error
Sea Level	25'
1,000'	25'
2,000'	25'
3,000'	25'
4,000'	25'
5,000'	25'
8,000'	30'
11,000'	35'
14,000'	40'
17,000'	45'
20,000'	50'

Table 9-1: Allowable Instrument Error

Altitude	Allowed Error
30,000'	75'
40,000'	100'
50,000'	125'

Allowable installed system error is added on top of instrument error and, these values are derived from the regulations as follows.

Table 9-2: Regulatory Reference

Regulation	Allowed Error
14 CFR § 23.1325	At sea level, the greater of 30' or 30% of the calibrated airspeed in knots. This increases proportionally to SAE AS8002A Table 1 at higher altitudes.
14 CFR § 25.1325	
14 CFR § 27.1325	
14 CFR § 29.1325	

An allowable altitude error is computed for each compared value and added together to create the altitude miscompare threshold. This accommodates for the values deviating in different directions.

Worked example for a calibrated airspeed of 100 knots and comparing a first altitude of 3,490' with a second altitude of 3,510':

- 1) Calculate allowable instrument error based upon altitudes:
 Allowable Instrument Error #1 = 50'
 Allowable Instrument Error #2 = 50'
- 2) Calculate allowable installed system error based upon altitudes and calibrated airspeed:
 Allowable Installed System Error #1 = 30'
 Allowable Installed System Error #2 = 30'
- 3) Calculate altitude miscompare threshold based upon sum of above allowable errors:
 Altitude Miscompare Threshold = 160'

9.7. Airspeed Miscompare Threshold

The airspeed miscompare threshold is based upon the allowable airspeed error. There are two components to allowable airspeed

error, instrument error and installed system error. Allowable instrument error is based upon the values of SAE AS8002A as follows.

Table 9-3: Airspeed Error	
Calibrated Airspeed	Allowed Error
50 knots	5 knots
80 knots	3 knots
100 knots	2 knots
120 knots	2 knots
150 knots	2 knots
200 knots	2 knots
250 knots	2.4 knots
300 knots	2.8 knots
350 knots	3.2 knots
400 knots	3.6 knots
450 knots	4 knots

Allowable installed system error is added on top of instrument. Error and these values are derived from the regulations as follows.

Table 9-4: Airspeed Regulatory Reference	
Regulation	Allowed Error
14 CFR § 23.1323	Starting from $(1.3 \times V_{S1})$: The greater of 5 knots or 3%. Do not perform a comparison if either value is below $(1.3 \times V_{S1})$.
14 CFR § 25.1323	Starting from $(1.23 \times V_{SR1})$: The greater of 5 knots or 3%. Do not perform a comparison if either value is below $(1.23 \times V_{SR1})$. System uses V_{S1} as a substitute for V_{SR1} .
14 CFR § 27.1323	Starting from $(0.8 \times V_{CLIMB})$: The greater of 5 knots or 3%. Do not perform a comparison if either value is below $(0.8 \times V_{CLIMB})$.

Table 9-4: Airspeed Regulatory Reference

Regulation	Allowed Error
14 CFR § 29.1323	<p>For Climbing Flight (VSI > 250 feet per minute):</p> <p>Starting from ($V_{TOS} - 10$): 10 knots</p> <p>Do not perform a comparison if either value is below ($V_{TOS} - 10$)</p> <p>For Other Flight Regimes:</p> <p>Starting from ($0.8 \times V_{TOS}$) The greater of 5 knots or 3%.</p> <p>Do not perform a comparison if either value is below ($0.8 \times V_{TOS}$).</p> <p>System uses V_{CLIMB} as a substitute for V_{TOS}.</p>

An allowable airspeed error is computed for each compared value and added together to create the airspeed miscompare threshold and accommodates for the values deviating in different directions.

Worked example for a rotorcraft climbing at 500 feet per minute and comparing a first airspeed of 80 knots with a second airspeed of 85 knots (V_{CLIMB} set to 75 knots in the aircraft limits):

- 1) Calculate allowable instrument error based upon airspeeds:
 Allowable Instrument Error #1 = 3 knots
 Allowable Instrument Error #2 = 2.75 knots
- 2) Calculate allowable installed system error based upon VSI, airspeeds and system limits:
 Allowable Installed System Error #1 = 10 knots
 Allowable Installed System Error #2 = 10 knots
- 3) Calculate airspeed miscompare threshold based upon sum of above allowable errors:
 Airspeed Miscompare Threshold = 25.75 knots

9.8. Jeppesen NavData Chart Compatibility

As GPS navigation, flight management systems, computer flight maps, and computer flight planning systems have gained acceptance, avionics companies, and software developers have

added more features. Even with many systems available today paper enroute, departure, arrival, and approach charts are still required and necessary for flight. Avionics systems, flight planning, computer mapping systems, and associated databases *do not* provide all of the navigation information needed to conduct a legal and safe flight. They are not a substitute for current aeronautical charts.

See www.Jeppesen.com for the latest information on coding instrument procedures, naming conventions, altitudes within the database, and aeronautical information compatibility.

9.9. ARINC 424 Path-Terminator Leg Types

Table 9-5: Path Terminators

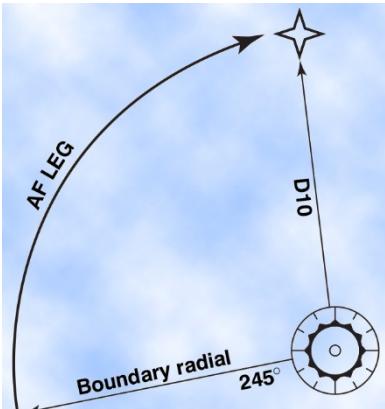
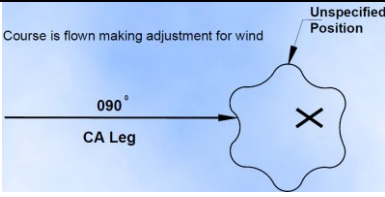
Type ARINC 424 Leg	Abbreviation	Example
DME Arc	AF	<p>Arc to a Fix or defines a track over ground a specified constant distance from a database DME Navaid.</p> 
Course to Altitude (Course is flown making adjustment for wind)	CA	<p>Course is flown making adjustment for wind</p> 

Table 9-5: Path Terminators

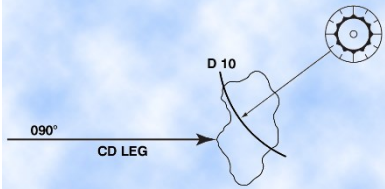
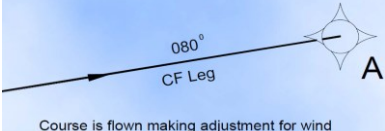

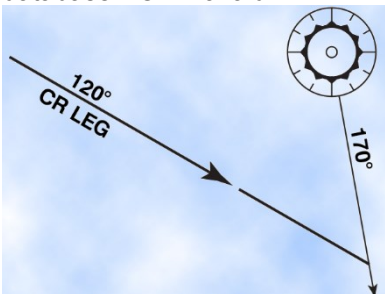
Type ARINC 424 Leg	Abbreviation	Example
Course to DME Distance	CD	<p>Course to DME Distance Leg defines a specified course to a specific DM Distance which is from a specific database DME Navaid.</p> 
Course to Fix	CF	 <p>Course is flown making adjustment for wind</p>
Course to Intercept	CI	<p>Course to an Intercept Leg defines a specified course to intercept a subsequent leg.</p> 
Course to Radial	CR	<p>Course to a Radial termination Leg defines a course to a specified Radial from a specific database VOR Navaid.</p> 

Table 9-5: Path Terminators

Type ARINC 424 Leg	Abbreviation	Example
Direct to Fix	DF	
Course from Fix to Altitude	FA	<p>FA leg is flown making adjustment for wind</p>
Course Fix to along Track Distance	FC	<p>Track from a Fix to a Distance Leg defines a specified track over ground from a database fix for a specific distance.</p>
Course from Fix to DME Distance (Different Fix)	FD	<p>Track from a Fix to a DME Distance Leg defines a specific track from a database fix to a specific DME Distance from a DME Navaid.</p>
Course from Fix to Manual termination	FM	<p>FM leg is flown making adjustment for wind</p>

Table 9-5: Path Terminators

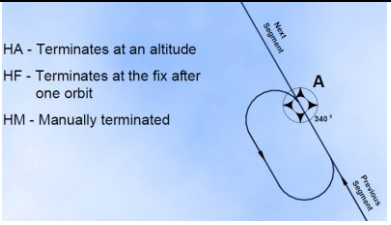

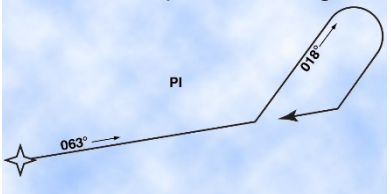
Type ARINC 424 Leg	Abbreviation	Example
Terminates at an altitude Holding, Pattern to Fix Altitude or Manual Termination	<p style="text-align: center;">HA</p> <p style="text-align: center;">HF</p> <p style="text-align: center;">HM</p>	<p>HA - Terminates at an altitude HF - Terminates at the fix after one orbit HM - Manually terminated</p> 
Initial Fix leg	<p style="text-align: center;">IF</p>	<p>The initial Fix Leg defines a database fix as a point in space.</p> <p>It is only required to define the beginning of a route or procedure.</p> 
Procedure Turn	<p style="text-align: center;">PI</p>	<p>Procedure Turn Leg defines a course reversal starting at a specific fix, includes Outbound Leg followed by 180 degree turn to intercept the next leg.</p> 

Table 9-5: Path Terminators

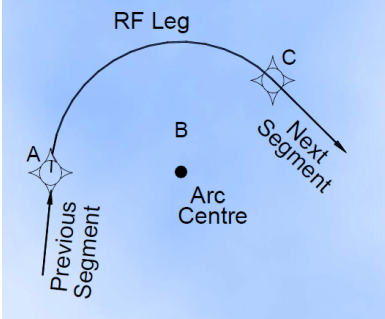

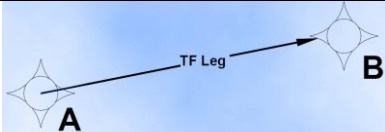
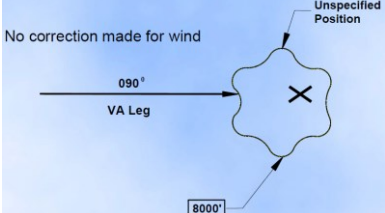
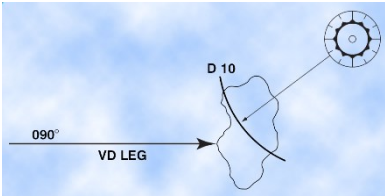

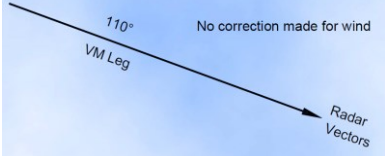
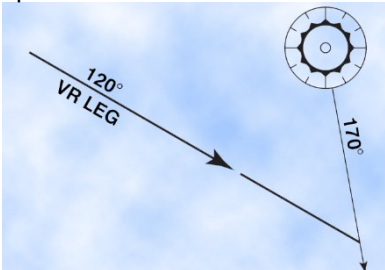
Type ARINC 424 Leg	Abbreviation	Example
Precision Arc to Fix	RF	
Track from Fix to New Fix	TF	<p>Track to a Fix defines a great circle track over ground between two known database fixes.</p> <p>Preferred type for straight legs.</p> 
Track to a Fix	TF	
Heading to Altitude	VA	<p>No correction made for wind</p> 

Table 9-5: Path Terminators

Type ARINC 424 Leg	Abbreviation	Example
Heading to DME Distance	VD	<p>Heading to a DME Distance termination Leg defines a specified heading terminating at a specified DME Distance from a specific database DME Navaid.</p> 
Heading to Intercept	VI	<p>Heading to an Intercept Leg defines a specified heading to intercept the subsequent leg at an unspecified position.</p> 
Heading to Manual Termination	VM	<p>Heading to a Manual Termination Leg defines a specified heading to a specified radial from a specific database VOR Navaid.</p> 
Heading to Radial	VR	<p>Heading to a Radial termination Leg defines a specified heading to a specified radial from a specific database VOR Navaid.</p> 

9.10. Data Logging and Retrieval

The Genesys Aerosystems EFIS logs all data associated with a flight, including all flight instrument and navigation data. This data may be downloaded for review after flight. Data from the last five flights or 20 hours are logged at a one-second interval.

Select the “Download LOG Files” option on the IDU to create a “\log” directory on the USB Memory and copy the data logging files into the “\log” directory of the USB Memory. The data logging files contain recordings of flight and engine parameters of up to five hours each from the previous five operations of the system. During system operation, flight and engine parameters are recorded every one second. Each time the parameters are recorded, a Zulu time stamp followed by three lines of comma delimited ASCII text data are written, where the first line contains flight parameters, and the second line contains engine parameters.

9.11. Log Files

9.11.1. Delete LOG Files

- 1) Select “Delete LOG Files” option to delete all log files contained in the log directory. This option may be performed if there are problems updating a navigation database or application software due to an excessively large log file.
- 2) The deleted files are named “LOG00.dat” thru “LOG04.DAT” and “MSGLOG.DAT”. Performing this option does not affect operations of the EFIS, as the EFIS automatically generates a new “LOG00.DAT” and “MSGLOG.DAT” file once a flight has started.
- 3) Press any button on the IDU or push **1** to return to the Ground Maintenance menu.

9.12. Routes and Waypoints

9.12.1. VFR Flight Planning

The navigation database includes VFR waypoints which consist of five digits beginning with the letters “VP”. These are found on VFR charts and should be loaded in the FMS prior to flight to ensure they are available in the database and the INFO checked for proper location.

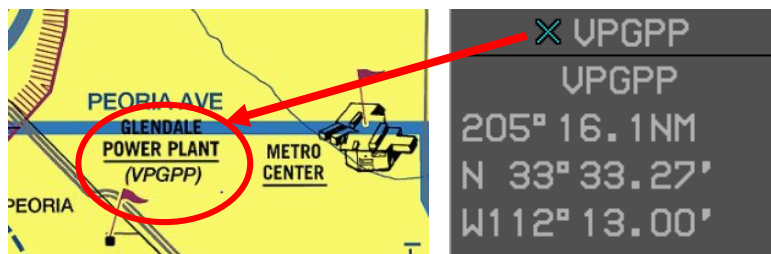


Figure 9-2: VFR Waypoint

9.12.2. Download Routes and User Waypoints

- 1) Select “Download Routes and User Waypoints” option from the Ground Maintenance Page to download all routes and user waypoints stored in the IDU to the USB External Memory Drive. This option is useful for fleet operations where multiple aircraft fly the same routes.
- 2) Routes are stored on the USB Memory external drive as NAME1-NAME2.RTE where NAME1 is the 1 to 5 character designation of the origin waypoint and NAME2 is the 1 to 5 character designation of the destination waypoint. User waypoints are stored on the USB External Memory Drive as USER.DAT.

9.13. EFIS Training Tool (ETT)

NOTE:

For installation directions and directions for using the features of the EFIS Training Tool (ETT), refer the Installation and User Manual distributed with the ETT install files.

9.14. Upload Routes and User Waypoints

Select “Upload Routes and User Waypoints” on the Ground Maintenance page option to copy all routes and user waypoints stored on a USB external memory drive to the IDU. This option used in conjunction with the “Download Routes and User Waypoints” option enables the operator to store the same routes and user waypoints in multiple aircraft.

9.14.1. Delete Routes

Select “Delete Routes” on the Ground Maintenance page option to remove all routes and the user waypoint file USER.DAT from the IDU. This option is used to delete the contents of the route directory when corrupted routes cause the IDU to continually reboot.

9.15. USB External Drive Memory Limitations

NOTE:

Maximum USB memory is not a factor but the following should be considered:

USB must be formatted as FAT.

FAT-16 for USB Drives 2 GB or smaller

FAT-32 for any larger sized drive. If the drive is not recognized try another source.

9.16. Service Difficulty Report

Print, complete, then fax to 940-325-3904

Name:	Phone:
Flight No:	Date:
Aircraft:	Registration#:
Software Version:	Error Code:
Route:	Duration of Flight:
Conditions:	
Remarks: (Include time, altimeter Setting, OAT, ALT, TAS, GS, Heading, track, position, flight segment, pilot action, system response, is problem repeatable?).	

9.17. Certification Basis

The following TSOs are considered applicable to the IDU-450 (depending upon the features of the installed software).

Document Number	Document Title
ARINC 429-16	Mark 33 Digital Information Transfer System (DITS)
ARINC 735A-1	Traffic Alert and Collision Avoidance System
EIA-232D	Interface between Data Terminal Equipment and Data
EIA-422A	Electrical Characteristics of Balanced Voltage Digital Interface Circuits
FAA AC 23.1311-1B	Installation of Electronic Display in Part 23 Airplanes
RTCA/DO-155	Minimum Performance Standards - Airborne Low-Range Radio Altimeters
RTCA/DO-229D	Minimum Operational Performance Standards for Global Positioning System/Wide Area Augmentation System Airborne Equipment
RTCA/DO-283A	Minimum Operational Performance Standards for Required Navigation Performance for Area Navigation
SAE AS396B	Bank and Pitch Instruments (Indicating Stabilized Type)
SAE AS8002A	Air Data Computer - Minimum Performance Standard
TSO-C4c	Bank and Pitch Instruments
TSO-C87	Airborne Low-Range Radio Altimeter
TSO-C106	Air Data Computer
TSO-C194	Terrain Awareness and Warning System

Document Number	Document Title	
TSO-C113	Airborne Multipurpose Electronic Displays	SAE AS8034
TSO-C52b	Flight Director Equipment	SAE AS8008
TSO-C146a	Stand-Alone airborne navigation equipment using the Global Positioning System (GPS) Augmented by the Wide Area Augmentation System (WAAS)	
N/A	Airplane Aerodynamics and Performance, Lan and Roskam, 1981.	

9.18. Environmental Requirements

The IDU-450 meets the requirements of RTCA/DO-160F as defined below:

Sec.	Condition	Cat.	Test Category Description	Notes
4.0	Temperature and Altitude	F2	<p>Equipment intended for installation in non-pressurized and non-controlled temperature location in an aircraft that is operated at altitudes up to 55,000 ft. (16,800 m) MSL.</p> <p>Ground Survival Low -55°C (non-operational test) Short-time operational Low - 40°C Operating Low Temp: -20° C</p> <p>Operating High temp: +70°C Ground Survival Low Temp: -55°C Ground Survival High Temp: +85°C Altitude: +55,000 feet</p>	<p>+75°C for Short-Time Operating High Temp. Cat. V (30 minutes) for loss of cooling.</p> <p>See Environmental Qualification Report (EQF) and Installation Manual.</p>
5.0	Temperature Variation	B	<p>Equipment in a non-temperature-controlled or partially temperature controlled internal section of the aircraft.</p>	

Sec.	Condition	Cat.	Test Category Description	Notes
6.0	Humidity	B	Equipment intended for installation in civil aircraft, non-civil transport aircraft and other classes, installed under conditions in which a more severe humidity environment than standard conditions may be encountered.	
7.0	Operational Shocks & Crash Safety	B	Equipment generally installed in fixed-wing aircraft or helicopters and tested for standard operational shock and crash safety.	Aircraft Type 5, Test Type R for Crash Safety Sustained Test

Sec.	Condition	Cat.	Test Category Description	Notes
8.0	Vibration	H + R + U	<p>H – Demonstrates performance at high-level, short duration transient vibration levels</p> <p>R - (Fixed-Wing) Demonstrates performance at higher, robust vibration levels and after long term vibration exposure.</p> <p>U - (Helicopter w/Unknown Frequencies) Demonstrates performance at higher vibration levels and after long term vibration exposure for fuselage and instrument panel equipment when the specific rotor frequencies are unknown.</p>	<p>Cat. H, curve R</p> <p>Cat. R, curves B, B1</p> <p>Cat. U, curve G</p>
9.0	Explosive Atmosphere	X	Not Applicable	
10.0	Waterproofness	W	Equipment is installed in locations where it may be subjected to falling water, such as condensation	Drip proof test
11.0	Fluids Susceptibility	X	Not Applicable	

Sec.	Condition	Cat.	Test Category Description	Notes
12.0	Sand and Dust	S	Equipment is installed in locations subject to blowing sand and dust.	
13.0	Fungus Resistance	F	Demonstrate whether equipment material is adversely affected by fungi growth.	By Analysis
14.0	Salt Fog	S	Equipment is subjected to a corrosive atmosphere	
15.0	Magnetic Effect	Z	Magnetic deflection distance less than 0.3m.	
16.0	Power Input	Z	Equipment intended for use on aircraft DC electrical systems where the DC supply has a battery whose capacity is small compared with the capacity of the DC generators.	200 ms power interruption capacity
17.0	Voltage Spike	A	Equipment intended primarily for installation where a high degree of protection against damage by voltage spikes is required.	

Sec.	Condition	Cat.	Test Category Description	Notes
18.0	Audio Frequency Conducted Susceptibility-Power Inputs	Z	Equipment intended for use on aircraft DC electrical systems where the DC supply may not have a battery of significant capacity floating on the dc bus at all times.	
19.0	Induced Signal Susceptibility	ZC	Equipment intended primarily for operation in systems where interference-free operation is required on aircraft whose primary power is constant frequency or DC.	
20.0	Radio Frequency Susceptibility (Radiated and Conducted)	Y	Equipment and interconnecting wiring installed in severe electromagnetic environments and to show compliance with the interim HIRF rules.	Radiated: K Minimum level at all frequencies to be 100V/m
21.0	Emission of Radio Frequency Energy	M	Equipment in areas where apertures are EM significant but not in direct view of aircraft antennas, such as passenger cabin or cockpit	

Sec.	Condition	Cat.	Test Category Description	Notes
22.0	Lightning Induced Transient Susceptibility	A3J33	Equipment interconnected with wiring installed within any airframe or airframe section when structural resistance is also a significant source of induced transients, (i.e., carbon fiber composite structures). Level 3 designates equipment and interconnecting wiring installed in a moderately exposed environment.	Level 4 for MSU and OAT Probe pins.
23.0	Lightning Direct Effects	X	Not Applicable	
24.0	Icing	X	Not Applicable	
25.0	Electrostatic Discharge (ESD)	A	Electronic equipment that is installed, repaired, or operated in an aerospace environment.	
26.0	Fire, Flammability	C	Non-metallic equipment, component parts, sub-assemblies installed in pressurized or non-pressurized zones and non-fire zones with largest dimension greater than 50 mm.	By Analysis

INDEX

A

Abbreviations and Acronyms	2-4
About This Guide	1-10
ACTV	5-14 to 16, 5-20 to 22, 5-37, 5-42 to 43, 5-47 to 50, 7-9
ADAHRS	2-4, 2-19 to 20, 3-92, 9-7 to 8
ADD	5-43
AGL Indication	3-30 to 31, 3-145 to 146, 3-149
Air Data	2-4, 2-20, 3-88, 3-110, 3-117, 3-132, 3-144, 3-149, 3-157, 5-86, 8-20, 8-29, 9-22
Aircraft Referenced	7-10
Airports	2-53, 3-109, 5-51, 5-56
Airspace	2-10, 2-13, 3-108 to 109, 4-7, 4-13 to 36, 7-6
Depiction	3-108 to 109
Airspeed	
Bug	3-34 to 35, 5-9, 5-73 to 74
Display	3-33 to 36
Miscompare Threshold	9-9 to 11
True	2-8, 2-13, 3-89, 3-111, 4-7, 4-14 to 36, 7-13 to 14
Altimeter	
Menu	5-82 to 83
Setting	3-22, 9-6
Altitude	
Capture Predictor	3-105
Display	3-25
Minimum	3-27, 5-9, 5-74

Miscompare Threshold.....	9-8 to 9
Analog AGL Indication	3-31, 3-146
Analog Navigation Symbolology	3-114
APP	3-101, 5-40
Appendix	1-13, 7-22, 7-25, 9-5
APPR.....	7-25, 7-31
Approach.....	2-4 to 10, 2-31, 2-48, 2-54, 3-58 to 59, 3-86,3-101 to 102, 3-129, 5-15 to 17, 5-38, 7-6 to 7, 7-12 to 15, 7-23 to 35, 7-40, 7-45 to 70, 8-4 to 9, 8-16, 8-27
APV	2-4, 7-7
ARM	5-17, 7-8
ASEL	2-4
Atmospheric perspective	3-19, 3-42 to 43
AUTO	3-73, 3-99, 3-159, 5-39, 5-98
Automatic RNP	3-58, 7-34
AW-109SP	1-9, 2-8, 2-18 to 20, 2-24, 2-27, 2-32 to 34, 2-43 to 48, 3-16 to 19, 3-23 to 25, 3-28, 3-36 to 41, 3-60 to 61, 3-65 to 70, 3-77 to 84, 3-94 to 96, 3-101,3-124 to 126, 3-147 to 151, 5-9, 5-14 to 17, 5-20, 5-49, 5-52 to 55, 5-67 to 71, 5-75 to 77, 5-81, 5-88, 6-2 to 5, 7-24, 7-34 to 35, 7-56
B	
BACK.....	3-21, 5-13
Bank Scale.....	3-19, 3-42, 3-53, 4-6, 4-13 to 36, 5-11, 5-81
Baro.....	2-17
BARO	3-21, 5-14, 5-18 to 22, 5-82, 6-3, 7-7
BARO-VNAV.....	7-7
Basic Mode.....	3-18, 3-41 to 44, 3-53, 3-56 to 57, 5-10, 5-78 to 79, 7-9
Basic Moving Map	3-85

Blue	3-71, 3-101, 3-109, 3-113, 3-129 to 130
Borders.....	3-112, 3-139
Brown	3-113
BUGS	1-9, 5-20, 5-67 to 71, 7-6, 7-40
Button/Menu Functions	1-6, 3-20, 5-1, 5-8, 5-12, 8-5

C

CALC.....	5-36
CDI Scale.....	3-93, 3-118, 7-28
Clock/Timers.....	3-99, 3-118, 3-132
Color Conventions.....	2-20
Compass Rose	3-83, 3-86, 3-92 to 94, 3-123 to 125, 3-141, 3-147, 4-7, 4-14 to 36
CONFIRM ACTIVATE ILS	5-57
CONT	2-46, 3-158, 5-16, 7-8
COUNT DN.....	3-99
Course Deviation Indicator	2-5, 3-30, 3-58 to 62
CRS SYNC	5-51 to 52, 5-57

D

Data Logging and Retrieval	9-18
Database	
Jeppesen.....	1-8 to 9, 1-12, 2-8, 2-50 to 51, 3-48, 9-11 to 12
NavData	1-10, 2-17, 2-50 to 53, 3-69, 3-85, 5-12, 5-38, 7-6, 7-14, 7-34, 7-56, 9-11
Navigation	1-9, 1-12, 2-21, 2-46, 2-50 to 52, 3-58, 3-74 to 76, 3-102, 3-144, 5-38, 7-7 to 9, 7-15, 7-20, 7-31, 8-26, 9-18
Obstruction.....	2-19, 2-50 to 52, 8-4
Datalink ...	2-17, 2-27, 3-20, 3-85, 3-109, 3-127 to 133, 3-137, 5-11, 5-13 to 5-18, 5-21, 5-89 to 99

DCLTR	3-99, 5-20, 5-78 to 81, 5-92, 5-100 to 101
Dead Reckoning	2-6, 2-34, 4-11, 7-22
Decision Height	2-5, 2-43, 3-30 to 32, 3-82, 3-146, 5-9 to 10,5-73 to 74
Default GPS/SBAS Navigation Modes	7-25
Delete	
Flight Plan	5-30
User Waypoint	5-34
DELETE	5-45
Demonstrator	1-8
Density Altitude.....	3-89, 3-111, 4-7, 4-14 to 36
Departure	2-6, 2-10, 2-31, 3-59, 3-102, 7-6, 7-25 to 28, 7-32 to 33, 7-36 to 37, 8-6 to 10, 8-27, 9-6
DESIG	5-20 to 21, 5-24
Direct	3-102 to 104, 5-14, 5-18, 5-46, 5-50, 5-60 to 62, 6-3, 7-15, 7-21 to 24, 9-14, 9-29
Direct-To	3-102 to 104, 7-15, 7-21 to 24
DISCONT	3-102
Discontinuity ...	3-103, 5-46, 5-60, 7-15 to 16, 7-21 to 23, 7-31 to 34
Display Symbology.....	3-1, 3-85, 8-5
DME	2-4 to 6, 2-14, 3-60, 3-90 to 91, 3-111, 3-116, 7-14 to 17,7-62 to 65, 9-12 to 14, 9-17
DP.....	2-6, 3-74, 3-102, 3-107, 3-143, 5-39, 5-41, 7-14 to 16, 7-23, 7-33, 8-6
E	
EFIS Training Tool (ETT).....	1-9, 2-6, 9-19
EFIS/FMS Description	1-6
EICAS.....	2-6

Encoder Functions	3-21
Enroute.....	2-6, 2-31, 3-59, 3-103, 3-110, 7-25 to 28, 8-6 to 9
Estimated Time of Arrival (ETA).....	2-6, 3-103 to 104
EXIT	3-21, 5-13, 5-36
F	
FAF.....	2-6, 3-101, 5-39, 7-16, 7-32, 7-56
FAULTS	2-27, 4-11, 5-21, 5-35, 5-84, 5-87, 7-34
FAWP	2-6, 2-48, 2-54, 3-59, 4-12, 5-39, 7-16, 7-26 to 28, 7-31, 7-34
Fixes.....	3-143, 5-56
Flight Path Marker	2-7, 2-45, 3-19, 3-43, 3-49 to 51, 3-57, 4-6, 4-9, 4-13 to 36
Flight Plan	
Activate.....	5-27
Active.....	3-83, 3-106, 3-121 to 126, 3-138, 3-142 to 143, 3-148, 3-154 to 155, 4-7, 4-13 to 36, 5-10, 5-37, 5-42, 5-47, 5-48 to 49
Edit	5-28 to 29
Path	3-83, 3-106, 3-121 to 126, 3-138, 3-142 to 143, 3-148, 3-154, 4-7, 4-13 to 36
Reverse	5-29
Flight Planning.....	9-5, 9-18
FLT TIME	3-99
FLTA.....	2-6, 2-24, 2-35, 2-40, 2-45, 2-50, 3-46, 3-113, 3-151, 5-15, 8-4 to 12, 8-27 to 33
FMS.....	1-10, 2-7, 2-16 to 17, 3-54, 3-59 to 65, 3-68, 3-78 to 79, 3-92 to 93, 3-102, 3-115 to 118, 5-10, 5-39, 5-53 to 54, 5-75 to 76, 5-89, 6-4, 7-9, 9-18
FORMAT.....	3-143, 5-21, 5-91, 5-94, 5-97 to 100

FOV Indication..... 3-107
FPL..... 5-14 to 15, 5-19 to 26
FROM Operation 7-13

G

General Arrangement 2-19
Geodesic Path 7-23
Geo-Referenced
 Backward 7-11
 Forward 7-11
Glideslope 2-23, 2-30, 2-36, 3-63 to 67, 3-90, 3-116, 8-4, 8-18,
 8-21, 8-30
GPS..... 2-7, 2-18 to 20, 2-30 to 39, 2-44 to 48, 3-30, 3-39, 3-51,
 3-58 to 65, 3-69 to 71, 3-90 to 93, 3-97 to 101, 3-106,
 ... 3-114 to 115, 3-118, 3-121 to 124, 3-138 to 139, 3-142 to 145,
 3-151, 4-5, 4-8 to 36, 5-35 to 38, 5-73 to 74, 5-84 to 85,
 7-6 to 8, 7-14, 7-22 to 25, 7-28 to 31, 7-34 to 35, 7-50 to 51,
 7-66 to 71, 8-6 to 10, 8-16, 8-20 to 29, 9-7 to 8, 9-11, 9-23
Aiding..... 2-20
ALMANAC..... 5-85
Altitude 7-22
FDE..... 5-85
HPL..... 5-85
LOI..... 5-85
PWR 5-84
SATLT 5-85
VPL..... 5-85
GPS/SBAS..... 2-19, 2-30 to 39, 2-44 to 48, 3-30, 3-58 to 62, 3-65,
 3-71, 3-90, 3-93, 3-99, 3-106, 3-114 to 115, 3-118,
 ... 3-121 to 124, 3-138 to 139, 3-142 to 145, 4-5 to 8, 4-16 to 36,

..... 5-35 to 36, 5-84 to 85, 7-7 to 8, 7-14, 7-22 to 25, 7-28 to 30,
 7-34, 8-6 to 10, 8-16, 8-20 to 29

GPWS..... 1-12, 2-7, 2-23 to 24, 2-30, 2-40 to 41, 2-47, 2-50, 8-4,
 8-12 to 21, 8-27 to 30

Gray 3-128 to 130

Groundspeed 2-31, 2-37, 3-88 to 89, 3-100, 3-110 to 111, 3-117,
 3-132, 3-144, 3-148 to 149, 3-157, 4-7, 4-13 to 36, 8-9

H

Heading

Display 3-37 to 39

Up.....3-86

Heading Bug 3-38, 3-62, 5-9, 5-55, 5-73

Helipad.....3-77

Heliport 3-76 to 77

Hidden Surface Removal Technique.....3-44, 3-69, 3-74, 7-9

Highway in the Sky. 3-43, 3-67 to 68, 4-6, 4-9, 4-14 to 36, 7-7 to 13

HOLD 3-116, 5-39

Holding Pattern 7-14 to 15, 7-20

Hover 3-20, 3-52 to 53, 3-140 to 148, 3-151, 4-6, 4-13 to 36,
 5-13 to 14

Page..... 3-147 to 148

Screen..... 3-140, 3-147

Vector..... 3-52 to 53, 3-140 to 147, 3-151, 4-6, 4-13 to 36

I

IAP 2-8, 7-14, 7-31

IAS 1-9, 2-8, 3-33, 3-52, 4-8, 5-68

IFR

APP 5-40, 8-23

Procedures.....	3-92, 7-6
ILS	2-8, 5-51, 5-57 to 59, 7-7, 7-30, 7-34, 7-40 to 44, 7-58 to 61,8-4, 8-18 to 21, 8-28 to 30
INFO.....	3-130, 5-14, 5-17 to 22, 5-35, 5-43 to 45, 5-50 to 52, 5-57, 5-61, 9-18
inHg/mbar	2-44, 3-21 to 22, 5-82 to 83, 8-24, 9-6
Initialization	1-8, 2-15 to 16, 2-19
INSERT	5-43
International Standard Atmosphere	3-89, 3-111
Introduction	1-5, 3-16
L	
Latitude/Longitude.....	5-51
LNAV	2-9, 2-45, 2-54, 3-25, 3-61, 3-65, 3-78 to 79, 3-102, 4-12, 5-15 to 16, 5-75 to 77, 7-6 to 9, 7-25 to 26, 7-29 to 31, 7-71
Approach.....	2-45, 7-25
LNAV/VNAV.....	2-45, 2-54, 3-65, 4-12, 7-6 to 7, 7-25 to 26, 7-29
Approach.....	2-45, 7-25
Log Files.....	9-18
LON	2-9, 3-45, 3-65, 3-71, 3-93, 4-12, 5-30 to 31, 8-20
LP	2-9, 2-45, 2-54, 3-58, 3-64 to 65, 7-6 to 7, 7-25 to 26, 7-29, 7-68
Approach.....	2-45, 7-25
LPV.....	2-9, 2-18, 2-45, 2-54, 3-58, 3-62 to 64, 7-6 to 7, 7-25 to 26, 7-29, 7-35, 7-50 to 51, 7-56
Approach.....	2-45, 7-25
M	
MA	3-101
Magnetic Course	7-21

MAHWP	2-9, 2-54
Map	3-32, 3-70 to 71, 3-86, 3-151, 3-158 to 160, 4-6, 4-14 to 36,
Mini	3-43, 3-70 to 71, 6-4
Moving.....	3-85 to 86, 3-151
Marker Beacon	3-54 to 55, 3-117
MAWP	2-9, 2-54, 7-26, 7-32 to 33
MENU	1-11, 5-14, 5-22 to 24, 5-87, 6-5
Menu Synchronization	5-8
MFD.....	1-6 to 11, 2-9, 2-15, 2-18, 2-22, 2-34, 3-16, 3-19 to 20,
.....	3-47, 3-53, 3-82, 3-151, 4-10 to 36, 5-8, 5-11 to 21,
.....	5-24 to 35, 5-84 to 101, 6-5, 8-5
Page	5-21
Minima.....	7-50 to 51
Minimums.....	2-43, 3-27, 3-101, 3-129
MINS	5-68
MISS.....	5-15 to 16, 7-8
Modes	
Mode 0	4-5, 4-13 to 15
Mode 1	2-24, 2-40, 2-50, 4-5, 4-16 to 18, 8-4, 8-12 to 13, 8-27
Mode 2	2-24, 2-31, 2-40, 2-50, 4-5, 4-19 to 21, 8-4, 8-14 to 15,
.....	8-27
Mode 3	2-41, 2-50, 4-5, 4-22 to 24, 8-4, 8-16, 8-27
Mode 4	2-31, 2-41, 2-50, 4-5, 4-25 to 27, 8-4, 8-17 to 18, 8-27
Mode 5	2-23, 2-30, 2-47, 2-50, 4-5, 4-28 to 30, 8-4, 8-18 to 21,
.....	8-27, 8-30
Mode 6	4-5, 4-31 to 4-33
Mode 7	4-5, 4-34 to 4-36

Mute 8-20

N

Nadir Symbol 3-40

NAV LOG 3-16, 3-150, 5-89 to 90

Navigation

 Data 2-51, 3-108, 3-143

 Log 3-85, 3-100

ND Screen 3-82

NDBs 2-21, 2-53, 3-108 to 110, 3-143, 5-44, 5-56 to 57

Nearest (NRST) Menu 3-104, 3-130, 5-14, 5-18 to 22,
 5-44 to 45, 5-49 to 50, 5-56 to 59, 7-35 to 57, 9-6

NIMA GEOMAG 7-21

NO RESULTS 5-44 to 45, 5-56

North Up 3-151

NRST ILS 7-35, 7-57

O

OBS 2-10, 2-16, 2-46, 3-61, 3-83, 3-93 to 95, 3-106, 3-118,
 3-121 to 124, 3-138 to 139, 3-142 to 143, 5-9, 5-14, 5-17,
 5-20 to 22, 5-53 to 54, 5-57 to 58, 5-74 to 76, 6-8, 7-7 to 8

 AUTO 5-53

 SYNC 5-53

Obstruction 3-44, 3-48, 3-112 to 113, 4-6 to 7, 4-13 to 36, 8-32

OFF 3-158, 5-14 to 16, 5-20 to 22, 5-31, 5-43, 5-57, 5-63, 5-77,
 5-86, 5-92, 5-97 to 99

OFLY/AUTO 5-39

Olive 3-113

Omnibearing Selector (OBS) Menu 5-53 to 54

Outside Air Temperature 2-10, 3-89, 3-111

OVERFLY	5-39
Overfly User Waypoint.....	5-24 to 25
Ownship symbol	3-71
P	
PAGE.....	5-21, 5-88 to 89
Pan Mode	3-114, 3-139, 3-162, 5-15 to 19, 5-24
Parallel Offsets	7-23
PDA	2-10
PFD....	1-6 to 7, 1-11, 2-10, 2-15 to 22, 2-34, 3-16 to 20, 3-25 to 26, 3-31, 3-37 to 57, 3-62, 3-69 to 82, 3-93, 3-99, 3-105 to 107, 3-115 to 118, 3-121, 3-124, 3-138 to 139, 3-142 to 144, 3-151, 4-6, 4-10 to 36, 5-10 to 15, 5-19 to 21, 5-24, 5-55, ...5-65 to 71, 5-75 to 83, 6-4, 7-6 to 8, 7-40, 8-4 to 5, 8-11, 8-20, 8-29 to 33, 9-8
Background	3-43
Declutter.....	3-54, 8-30
Symbology	3-25 to 26, 3-78
Pitch Scale.....	3-39 to 41, 4-6, 4-14 to 36
Popup	8-11 to 12
Procedure Turn.....	7-19, 9-15
Projected Path	3-106, 3-144, 4-7, 4-13 to 36
PTK.....	2-46, 3-102, 5-37, 5-43, 7-23
PTR.....	3-89 to 91
Q	
QFE	2-11, 2-44, 3-22, 5-82, 8-24
QNE	2-11, 3-22, 5-82 to 83, 8-24
QNH.....	2-11, 3-22, 5-82 to 83, 6-3, 8-22 to 25
QUICK START	1-11

Quick Start Tutorial 6-1

R

RAIM 2-11, 5-23, 5-35 to 36

 Prediction 5-35 to 36

Range 2-29, 2-50, 3-45, 3-97 to 98, 3-107 to 108, 3-120, 3-123,
 3-129, 3-137, 3-140, 3-146, 3-153, 3-156 to 158, 4-7,
 5-85 to 86, 8-8, 9-22

Remote Bugs Panel (RBP) 2-11, 5-15 to 17, 5-55, 5-72 to 75

Reversionary Modes 4-1, 4-5 to 6

RNAV 2-11, 2-54, 7-6, 7-15, 7-35, 7-49 to 55, 7-66 to 70

 DPs 2-54

RNP 2-11, 2-53 to 54, 3-58, 3-65, 5-54, 5-85, 7-16, 7-28, 7-34

 AUTO 5-54

 MAN 5-54

 Manual 2-17, 3-58, 5-54, 7-33

Rotorcraft 3-37, 3-44, 3-55 to 56, 3-77, 4-8 to 9, 6-2, 8-4,
 8-13 to 21, 9-5

Runways 3-43, 3-74 to 75, 3-106, 3-121 to 123, 3-138, 3-143,
 3-154

S

SBAS 2-12, 2-31 to 32, 2-39, 2-44 to 46, 3-65, 3-99, 3-106,
 3-121, 3-124, 3-138 to 139, 3-142 to 145, 4-10 to 12,
 5-35 to 36, 5-85, 7-6 to 7, 7-22, 7-29 to 30, 8-6, 8-20, 8-23, 8-29

SBAS HLTH 5-85

SBAS MSG 5-85

Search Envelope 8-8

Skyway 2-21, 3-67, 5-11, 5-79, 7-8 to 9

STAR 2-13, 3-74, 3-102, 3-107, 3-143, 5-39 to 40, 7-14, 7-34,
 7-38 to 40, 8-6

Start Point.....	3-104 to 105
STD.....	5-83
STORE	5-63
Strikes.....	3-85, 3-119, 3-136, 5-93
SYMB DCLTR	5-92
SYNC.....	3-161, 5-20, 6-8 to 10
System Overview.....	2-15, 9-6
T	
Target Altitude	3-22 to 23, 5-9
Terminal.....	2-13, 2-31, 2-47, 3-59, 3-102, 3-110, 7-25 to 28, 7-38, 8-6 to 9, 8-27, 9-22
Terrain	2-6, 2-13, 2-24, 2-40 to 41, 2-51, 2-54, 3-19, 3-42 to 47, 3-99, 3-112 to 114, 4-6 to 7, 4-13 to 36, 5-11, 5-93, 8-4 to 5, 8-11, 8-14 to 17, 8-25 to 33, 9-5, 9-22
Database.....	2-51, 2-54, 8-25
Rendering	3-19, 3-42, 8-11
TIMER.....	5-20 to 21, 5-63 to 64
Timer Indication	3-54
Too Low.....	2-41, 8-17
Top of Descent (TOD)	3-62 to 63, 3-105
Top-Level Menu.....	5-13 to 15
Traffic.....	2-4 to 5, 2-10 to 13, 2-25, 2-42, 2-50, 3-20, 3-28, 3-32, 3-43, 3-71 to 74, 3-85, 3-99, 3-122 to 124, 4-6 to 7, 4-13 to 36, 5-9 to 14, 5-21, 5-89, 5-93, 5-98, 9-22
TRANS.....	5-83
Transmit Enabled	2-15, 4-7
TSO	1-12, 2-14, 3-58, 3-61, 7-6 to 8, 7-56, 8-4 to 6, 9-22 to 23

U

Unusual Attitude Mode	3-18, 3-42 to 44, 3-50 to 53, 3-64,3-69 to 72, 7-9
USB	1-6 to 8, 2-51 to 52, 9-18 to 20
USER WPT	5-24

V

VDI	3-43, 3-63, 3-90, 3-115, 7-7
Vertical Deviation Indicator	3-62 to 67, 3-95, 7-8
Vertical Speed Indicator	2-8, 2-14, 3-27
VFR	1-5, 2-14, 2-21, 2-31, 2-48, 3-74, 3-101 to 102, 3-107 to 109, 3-129, 3-143, 5-31, 5-38 to 40, 5-92, 7-12 to 14, 7-23 to 27, 7-32, 8-6, 8-23, 8-27, 9-18 to 19
VNAV.....	2-14, 2-21, 2-42, 2-49, 2-54, 3-23 to 27, 3-62 to 66, 3-69, 3-78 to 79, 3-102, 3-105 to 106, 3-115 to 116, 3-123, 3-138, 5-9, 5-16 to 17, 5-38 to 39, 5-68 to 69, 5-75 to 77, 7-8 to 13,7-30, 9-5
CDA	5-68
Sub-Mode	3-23 to 24
VOR DME.....	7-35
VORs.....	2-21, 2-53, 3-110, 3-143, 5-45, 5-56 to 57
VSI.....	2-14, 2-21, 2-25, 2-49, 3-27 to 29, 3-73, 3-123, 3-138, 4-6,4-14 to 36, 5-9, 5-68 to 69, 5-73 to 76, 6-4, 8-10, 8-28 to 29,9-11
VTF.....	2-14, 3-59, 7-26 to 28, 7-31 to 32

W

WAAS.....	2-14, 7-6, 9-23
Water.....	3-113
Waypoint	2-6 to 9, 2-54, 3-68 to 70, 3-84, 3-96 to 97, 3-101 to 104, 3-119, 3-125 to 126, 3-150, 3-161, 4-6 to 7, 4-13 to 36, 5-35, 6-4, 7-12 to 19, 7-24, 9-19

Active 3-43, 3-68 to 70, 3-83 to 84, 3-96, 3-125 to 126, 6-4

Create User..... 5-30 to 32

Edit User5-33

Identifier 3-68, 3-101 to 104

Overfly User 5-24 to 25

Phantom.....7-15

Pointer..... 4-6 to 7, 4-13 to 36

Routes and User9-19

Sequencing7-13

Waypoints

 Fly-By.....7-16

 Fly-Over7-14

WGS-84 2-53, 7-17 to 23

Wind..... 3-88, 3-110 to 111, 3-130, 4-7, 4-14 to 36

WX-RDR 3-16, 5-89

X

XFILL SYNC 5-19 to 20

Z

Zoom Mode5-10

Zulu time 3-144, 9-18

Glossary

AGL Indication (Rad Alt, GPS Alt, Baro Alt) – Display of altitude above the ground, with designation of the altitude source as R (radio altitude), G (GPS WAAS geodetic altitude less local ground elevation), or B (barometric altitude less local ground elevation).

Air Data and Groundspeed – Display of density altitude, outside air temperature, ISA temperature deviation, true airspeed, and ground speed.

Airspeed Information – Display of airspeed is the indicated airspeed tape and airspeed readout with associated data. The airspeed function includes color-coded caution bands for minimum and maximum speeds based on V-speeds set in the EFIS limits.

Altitude Information – Display of altitude information is the altitude tape and altitude readout.

Approach Mode Signal Output – Conventional autopilot approach mode signals are course error output, the left/right deviation signal (localizer output) and the up/down deviation signal (glideslope output). Signals are based on the selected ILS source.

Attitude Information – Display of attitude information includes pitch and roll. The bank angle scale may be set to auto-declutter by the pilot when the bank angle is less than 2.8°. The pitch ladder is limited to $\pm 10^\circ$ from the flight path marker or aircraft waterline, whichever is greater. The unusual attitude display appears when the aircraft pitch exceeds $\pm 30^\circ$ or bank angle exceeds 65° (fixed wing) or 50° (rotorcraft).

Autoset – Automatically selects features or settings.

Azimuth – Angle between the north vector and the perpendicular projection of the star down onto the horizon. Usually measured in degrees ($^\circ$).

Barometric Altimetry – Measurement of altitude based on the atmosphere (pressure and temperature).

Barometric Correction – Display and altitude correction for local barometric pressure.

Bezel – Faceplate of the IDU comprised of pushbuttons along the pushbuttons along the sides and rotary encoders along the bottom.

Chroma – Colorfulness relative to the brightness.

Conformally – Angle-preserving. Example: Traffic appears conformally on the PFD.

Course Deviation Indicator – Display of course deviation from selected course, including a To-From indicator.

Critical Flight Phase – Phase(s) of flight where the failure mode would result in a hazard condition using flight phases. For example, failure of ILS would only be a hazard condition during approach and landing.

Crossfill – Transfer of data and information between IDUs in a dual system with two PFDs configured.

Cross-linked – Synchronized across both EFIS systems.

Datalinked – Display of received data such as weather or traffic from peripheral systems such as WSI or ADS-B.

dBZ – Decibel relative to radar reflectivity (Z). Composite reflectivity shows the highest dBZ (strongest reflected energy) at all elevations. Unlike base reflectivity, which only shows reflected energy at a single elevation scan of the radar, composite reflectivity displays the highest reflectivity of ALL elevations scans. If there is heavier precipitation in the atmosphere over an area of lighter precipitation (i.e. rain has yet to reach the ground), the composite reflectivity displays the stronger dBZ level.

Deadband – Neutral zone where no action or changes are made.

Directional Scale (Compass Rose or Arc) and Ownship Symbol – Display of general directional information. All MFD pages include a form of the compass rose with current heading pointer and aircraft “ownship” symbol.

Discrete – A logic input or output that identifies a condition or status of or for an ancillary system. Discretes are defined by the operating software or settings programmed specifically for the aircraft.

Display of ADF – Display of single ADF bearing information in the form of an RMI needle.

Display of Glideslope – Display of Glideslope 1 or Glideslope 2 in the form of vertical deviation dots and deviation on PFD or MFD HSI page.

Display of Lightning Cell Information – Display of lightning information from a WX-500 system and shown in the form of lightning cells. The pilot may show individual lightning strike data by selecting the dedicated WX-500 page.

Display of Localizer – Display of Localizer 1 or Localizer 2 in the form of horizontal deviation dots and deviation.

Display of Marker Beacon – Display of outer, middle, and inner marker beacons in the form of a color-coded circle with the corresponding letter (O, M, I).

Display of Traffic Information – When integrated with an appropriate traffic system, the PFD and MFD display traffic information in two formats. One format is via traffic symbols as shown on the PFD and MFD Map page and Traffic page. The second format is with the traffic pop-up thumbnail display showing traffic position in a full 360° format on the PFD.

Display of VOR RMI – Display of VOR1 and VOR2 bearing in the form of RMI needles.

Dot – (CDI scale referenced) represents an additional 2° for VOR and 1.25° for Localizer.

Failure Condition Hazard Description – A description of the failure mode to be analyzed.

Flight Director (Selectable Function) – Display of flight director in a single or dual cue format when selected for display on the PFD.

Flight Path Marker (Velocity Vector) – Display of aircraft's actual flight path, showing where the aircraft is going as opposed to where the aircraft is pointed.

Flight Plan and Navigation Display – Display of the active GPS WAAS/SBAS-based flight plan, including course line, waypoints, ground track, glide range, projected path, altitude

capture predictor, approach procedure, missed approach procedure, and the aircraft present position on the active leg.

Geodetic – Set of reference points used to locate places on the earth.

Geoid – Global mean sea level.

G-Force and Fast/Slow Indicator – Indications to show the G-force on the aircraft or, for aircraft equipped with a compatible angle of attack computer, the deviation from the reference speed while in the landing configuration.

Glideslope Sidelobes – False glideslope signals.

GPS WAAS Course Deviation Indicator (CDI) – Display of CDI relative to selected course, either automatic based on active flight plan or manual based on pilot-selected OBS.

GPS WAAS Functions – The EFIS meets the GPS WAAS navigation and flight planning/management requirements of TSO-C146a (RTCA/DO-229D) for Class Gamma 3 equipment. These functions include navigation, flight planning (function select, flight plan generation and editing, selected waypoints, user waypoints, etc.), path definition including approach and departure paths, GPS altitude, dead reckoning, navigation modes with automatic mode switching, loss of navigation monitoring, loss of integrity monitoring, etc. The database used with the GPS WAAS functions meets the integrity requirements of RTCA/DO-200A.

Heading Bug – Display and control of selected heading using a bug. May be used to drive heading bug output to autopilot for HSI-based heading mode.

Heading Display – Display of heading with directional scale is provided at the top of the PFD. This is the same heading information provided on the MFD.

Heading Mode Signal Output – Conventional autopilot heading mode signal is a heading error output based on the difference between the EFIS desired heading and the actual aircraft heading. The EFIS desired heading is either the pilot-selected heading bug or a heading designed to achieve and maintain the active GPS-based flight plan.

Hectopascal (hPa) – International System of Units (SI) unit measure of pressure, equals one millibar (mbar).

HeliSAS – Genesys Aerosystems' helicopter autopilot and stability augmentation system.

Horizontal Situation Indicator (Selectable Function) – Display of VOR or localizer and glideslope deviation when selected for display on the PFD.

Hover Vector Display (Rotorcraft Only) – Display of hover drift in a rotorcraft installation when the helicopter is traveling less than 30 knots airspeed.

Inches of Mercury (inHg) – Unit of atmospheric pressure used in the United States. Named for the use of mercurial barometers which equate height of a column of mercury with air pressure.



Inhibit – Prevention of activity or occurrence. Examples are: **XFILL INHBT**, **TAWS INHBT**, and **TAS INHBT**.

Integrated Peripherals – Internal devices of the essential unit.

Intelliflight – Genesys Aerosystems' digital autopilot.

Ionosphere – Region of the atmosphere between the stratosphere and exosphere, 50 to 250 miles (80 to 400 km) above the surface of the earth.

International Standard Atmosphere (ISA) – Standard model of the change of pressure, temperature, density, and viscosity over a wide range of altitudes or elevations.

Landing Gear Indication – When enabled on retractable landing gear aircraft, PFD shows indication of landing gear extended.

Lubber Line – Line marked on the compass showing the direction straight ahead.

Mach Display – Display of Mach number when the aircraft is traveling at or above 0.35 Mach. This function may be deselected by a setting in the IDU configuration (limits) file.

Magnetic Declination (MAGVAR) – Sometimes called magnetic variation; the angle between magnetic north and true north.

Map Data – Display of map data, including airspace, VFR/IFR airports, VHF nav aids such as VOR/NDB/DME, jet/victor airways, and display range rings.

Menu Functions – The EFIS includes menus to access functions on both the PFD and the MFD.

Mesocyclonic – Contains a vortex of air within a convective; air rises and rotates around a vertical axis, often in the same direction as low pressure systems.

Millibar (mbar) – Metric (not SI) unit of pressure, one thousandth of a bar (which is about equal to the atmospheric pressure on Earth at sea level - 1013 millibars).



Miscompare – Disparity of data or information. Examples are:

ALT MISCOMP, **ATT MISCOMP**, **GPS MISCOMP**,
GS MISCOMP, **HDG MISCOMP**, **IAS MISCOMP**,
LOC MISCOMP, **PLT MISCOMP**, **RALT MISCOMP**,
CPLT MISCOMP, and **BARO MISCOMP**.

NavData – Jeppesen's aeronautical database to navigate the global airspace system.

Navigation Data Display – Display of active waypoint, bearing to waypoint, and ground track based on active flight plan. The pilot may also select flight plan information as a mini-map (thumbnail map). These functions are analyzed as part of the GPS WAAS functions not the PFD functions.

Navigation Log – Display of navigation information based on active flight plan, including next waypoint, destination, estimated time remaining, and fuel totalizer-based range and endurance. This function may be deselected by a setting in the IDU configuration (limits) file. These functions are analyzed as part of the GPS WAAS functions not the MFD functions.

Navigation Mode Signal Output – Conventional autopilot Navigation mode signals are the course error output and the left-right deviation signals. Course error output is based on the difference between the EFIS selected course (OBS) and the actual aircraft heading. These signals are based on the selected navigation signal (VOR, GPS).

Nondirectional – Functions in all directions.

Noodle – Navigation Display (ND) Projected path; curving path based upon the aircraft bank angle and ground speed used effectively to assist in course interception and making small adjustments to bank angle for proper roll out.

Nanoteslas (nT) – A unit of measurement of the strength of the magnetic field. Earth's strongest magnetic field is located at the poles, and the weakest field is near the equator.

Obstructions Display – Display of obstructions identified in the embedded obstruction database which are within 8.5 NM of the aircraft present position. Non-threatening obstructions are displayed by color to identify altitude relative to the aircraft's current altitude (amber [yellow] < 2000' below, light red < 500' below, bright red = at or above aircraft). Threatening obstructions, defined as those that pierce the TAWS envelope, are identified by highlight when producing a caution and identified by flashing highlight when producing a warning. The database used with the obstruction functions meets the integrity requirements of RTCA/DO-200A.

Omnibearing – Magnetic bearing of an omni-range station.

Ownship – Principal eye-point; referring to icon of aircraft represented on display.

Pitch Limit Indicator – Appears when the aircraft (fixed wing only) is within 10 knots of stall speed, based on the VSI setting in the EFIS limits. The intent is to notify the pilot of a possible stall condition so corrective action is taken before the stall occurs. This function may be deselected by a setting in the IDU configuration (limits) file.

Q-Routes – Published RNAV routes, including Q-Routes and T-Routes, can be flight planned for use by the Genesys EFIS, subject to any limitations or requirements noted on enroute charts, in applicable Advisory Circulars, or by NOTAM. RNAV routes are depicted in blue on aeronautical charts and are identified by the letter "Q" or "T" followed by the airway number. E.g., Q35, T-205. Published RNAV routes are RNAV-2 except when specifically charted as RNAV-1.

QFE – Barometric setting that results in the altimeter displaying height above a reference elevation (e.g., airport or runway threshold).

QNE – Standard barometric setting (29.92 inHg or 1013 mbar) used to display pressure attitude for flight above the transition attitude.

QNH – Barometric setting that results in the altimeter displaying altitude above mean sea level at the reporting station.

Recency – State of occurrence, appearance, or origin.

Selection and Display of Selected Course – Omni-Bearing Select (OBS) function for the pilot to select the course for navigation. Selected course is displayed for reference.

Settable V-Speeds, Targets – The pilot may set certain V-speeds for reference during flight. In addition, the pilot may set certain information at any time for reference during flight, including target airspeed (with corresponding bug) and target altitude (with corresponding bug).

Side in Command – Side of aircraft control responsible for its operation.

Skipped Waypoint – A skipped waypoint is a waypoint associated with a dynamic termination leg with a zero length. These are either:

- 1) An altitude termination leg when current aircraft altitude is above the termination altitude; or
- 2) System-created (i.e., not NavData specified) intercept to a “Course to a Fix” leg where there is insufficient distance to calculate an intercept heading.

Skyway VNAV/LNAV Guidance (Synthetic Vision) – Display of GPS-based active navigation route, flight plan, procedure, or OBS course in a three-dimensional series of skyway boxes. Also known as Highway in the Sky and HITS.

Slip Indicator – Display of aircraft lateral accelerations via an integral slip/skid indicator function. The slip indicator is a rectangle just below the heading pointer that moves left and right to indicate the lateral acceleration sensed by the AHRS in the same manner as the ball in a mechanical slip indicator.

Strikefinder – Lightning detector system (WX-500) connected to EFIS and enabled through Factory Program settings.

Suppressed Waypoint – A suppressed waypoint (designated by brackets) is an airport associated with an IFR or VFR approach procedure.

Symbology – Use of symbols.

T-Routes – T-Routes are available for use by GPS or GPS/SBAS equipped aircraft from 1,200 feet above the surface (or in some instances higher) up to but not including 18,000 feet MSL. T-Routes are depicted on Enroute Low Altitude Charts and considered to include the same attributes of Low Altitude Airways in the Genesys Aerosystems EFIS Declutter menus.

Talker – IDU providing data to external sensors and generating aural alerts. IDUs depend upon intra-system communications to determine which IDU on a side takes over “Talker” responsibilities. Only one talker (transmit enabled) per side, two talkers in a two sided system, and a master talker PFD when considering aircraft limits. Any IDU may become a talker through auto reversionary means in the event of the PFD failing.

Terrain Display (PFD Artificial Horizon) – Conformal display of surrounding terrain presented with the artificial horizon, shown in the correct scale and perspective for the aircraft’s current position and altitude. Includes conformal display of known runway locations, direction, scale, and perspective based on aircraft’s current position and altitude.

Terrain Display and TAWS/HTAWS – Display of terrain, including identification and annunciation of threatening terrain in accordance with Terrain Awareness Warning System (TAWS) requirements. Coloring scheme for SVS-TAWS PFD and MAP has been simplified as follows:

Non-alerting Terrain below aircraft – Olive Shades

Non-alerting terrain above aircraft – Brown Shades

TAWS FLTA Caution Terrain – Amber (Yellow)

TAWS FLTA Warning Terrain – Red

Obstacles Below aircraft – Amber (Yellow)

Obstacles above aircraft – Red

When over water – Deep Blue

Threatening terrain is determined by the requirements of TAWS TSO-C151b (fixed wing) and TSO-C194 HTAWS (rotorcraft). Threatening terrain is shaded amber (yellow) for caution situations or shaded red for warning situations per TSO-C151b and TSO-C194. TAWS cautions and warnings are accompanied by an amber (yellow) or red flag and an aural annunciation. TAWS Class A, TAWS Class B, TAWS Class C, Enhanced HTAWS, or HTAWS functions may be activated in the system prior to installation. The database used with the TAWS functions meets the integrity requirements of RTCA/DO-200A.

Timer Indication – Pilot-selected function for a count-up or count-down timer.

Traffic Display – When integrated with an appropriate traffic system, traffic is shown using standard TCAS symbology showing relative position, altitude, climb/decent, and color. The pilot may also show traffic information by selecting the dedicated traffic display page.

Vertical Speed Display – Display of altitude rate of change (vertical speed or climb rate).

V_{PROC} (Procedure Speed) – The aircraft's normal speed (in Airspeed Units and configured in EFIS Limits) for flying instrument approaches (DPs, IAPs, STARs). This value is used for calculating the turn radius used for instrument procedure legs. This speed is not seen on the airspeed tape and only found in the aircraft speed settings inside the limits.

Warning, Caution, and Advisory Flags – Display of, warning, caution, and advisory indications accompanied by aural indications. The flags are stacked in the lower left corner of the PFD. Warnings are always shown at the top of the flag stack, followed by cautions and then advisories. These flags remain in view for as long as the situation exists.

Waterline – Indication of the aircraft's longitudinal axis or waterline (attitude).

Wide Area Augmentation System (WAAS) – Developed by Federal Aviation Administration to provide accurate positioning part of the Satellite Based Augmentation System (SBAS). Other

countries have similar systems: Europe: European Geostationary Overlay System (EGNOS); Japan: MTSAT Satellite-based Augmentation System (MSAS); India: GPS Aided GEO Augmented Navigation system (GAGAN).

Wind Information – Display of wind direction, wind speed, and cross wind component.

Zulu Clock, Timers – Display of Zulu time (based on GPS data) and pilot-selected timer.



IDU-450 Version 8.0D Pilot Guide (Rotorcraft)