



Pilot Operating Guide and Reference

(Fixed Wing)

EFIS Software Version 8.0K

Document 64-000099-080K

This pilot guide must be carried in the aircraft and made available to the pilot at all times. It can only be used in conjunction with the Federal Aviation Administration (FAA) approved Aircraft Flight Manual (AFM). Refer to the applicable AFM for aircraft specific information, such as unique ground tests, limitations, and emergency procedures.

© 2020 Genesys Aerosystems All Rights Reserved

No part of this document may be reproduced in any form, or by any means, without prior written consent of Genesys Aerosystems.

FlightLogic and Virtual VFR are trademarks of Genesys Aerosystems. All other brand names and trademarks are the property of their respective holders.

For service or repairs, contact an authorized Genesys Aerosystems dealer. For product support or inquiries regarding this pilot guide, contact Genesys Aerosystems.

One S-TEC Way, Municipal Airport, Mineral Wells TX 76067

Phone: (800) 872-7832 Fax: (940) 325-3904

www.genesys-aerosystems.com

Revision Record

Rev	Notes/Pages changed, added, or deleted by current revision	Date	Author

Retain this record in front of pilot guide. Upon receipt of a revision, insert changes and complete table below.

Revision or Edition	Revision Date	Insertion Date/Initials

Table of Contents

Section 1	Introduction	1-1
1.1.	Introduction	1-1
1.2.	EFIS/FMS Description	1-1
1.3.	About This Guide	1-2
Section 2	System Overview	2-1
2.1.	Abbreviations and Acronyms	2-1
2.2.	System Overview	2-11
2.2.1.	Functional Integration and Display Redundancy	2-16
2.2.2.	IDU Initialization	2-17
2.3.	General Arrangement	2-23
2.3.1.	Normal and Essential Modes	2-24
2.3.2.	Data Source Monitors	2-25
2.3.3.	IDU Intra-System Communications.....	2-26
2.4.	Color Conventions.....	2-26
2.5.	AHRS Fast Slave and Erect.....	2-28
2.6.	Warning/Caution/Advisory System	2-28
2.6.1.	Time-Critical Warning and Caution Alerts.....	2-29
2.6.2.	Warning Alerts.....	2-32
2.6.3.	Caution Alerts.....	2-33
2.6.4.	Side-Specific Caution Alerts	2-40
2.6.5.	Advisory Alerts	2-40
2.6.6.	Side-Specific Advisory Alerts	2-42
2.6.7.	Audio-Only Caution and Advisory Alerts.....	2-44
2.6.8.	Voice Alerts and Muting	2-46
2.6.9.	Visual Alert Prioritization and Declutter.....	2-46
2.7.	Database and Software Updates	2-47
2.7.1.	Navigation and Obstruction Database	2-47
2.7.2.	Update Requirements	2-48
2.7.3.	Software and Terrain Database Update	2-50
2.8.	Demonstrator	2-50

2.9.	EFIS Training Tool.....	2-51
2.10.	Application Software Air Mode and Ground Mode	2-51
Section 3	Display Symbology	3-1
3.1.	Introduction	3-1
3.1.1.	PFD Display (Basic Mode).....	3-2
3.1.2.	MFD Display	3-3
3.2.	Menu Functions	3-5
3.3.	PFD Symbology.....	3-6
3.3.1.	Altitude Display	3-7
3.3.1.1.	Altitude Display (Metric Units).....	3-7
3.3.2.	Altimeter Setting.....	3-8
3.3.3.	Selected Altitude Sub-Mode (Target Altitude)	3-8
3.3.4.	Altitude Display (VNAV Tile).....	3-9
3.3.5.	VNAV Sub-Mode.....	3-9
3.3.6.	Minimum Altitude	3-10
3.3.7.	Vertical Speed Indicator.....	3-11
3.3.8.	Normal AGL Indication.....	3-12
3.3.9.	Analog AGL Indication	3-13
3.3.10.	Decision Height.....	3-14
3.3.11.	Airspeed Display	3-14
3.3.12.	Airspeed Display (with EFIS-Coupled)	3-18
3.3.13.	Heading Display.....	3-19
3.3.14.	Pitch Scale	3-20
3.3.15.	Pitch Limit Indicator	3-21
3.3.16.	Turn Rate Indicator	3-22
3.3.17.	G-Force Indicator	3-22
3.3.18.	Landing Gear Indication.....	3-23
3.3.19.	Unusual Attitude Mode	3-23
3.3.20.	PFD Background.....	3-24
3.3.21.	Flight Path Marker (Velocity Vector).....	3-28
3.3.22.	Bank Angle Scale	3-30
3.3.23.	Timer Indication	3-31

3.3.24.	Marker Beacon Symbology	3-31
3.3.25.	Flight Director Symbology	3-31
3.3.26.	Course Deviation Indicator.....	3-33
3.3.27.	OBS Setting of CDI	3-35
3.3.28.	Heading/Roll-Steering Sub-Mode	3-36
3.3.29.	No Autopilot or Fully-Integrated Autopilot CDI.....	3-36
3.3.30.	Vertical Deviation Indicator (VDI).....	3-36
3.3.31.	Vertical Deviation Indicator (EFIS Coupled)	3-38
3.3.32.	Highway in the Sky/Skyway	3-39
3.3.33.	Active Waypoint and Waypoint Identifier	3-39
3.3.34.	Mini Map.....	3-40
3.3.35.	Runways	3-41
3.3.36.	Genesys/S-TEC DFCS Autopilot Annunciations	3-42
3.4.	MFD Symbology.....	3-43
3.4.1.	Ownship Symbology	3-43
3.4.2.	Moving Map.....	3-43
3.4.3.	Compass Rose/ND Boundary Circle Symbol	3-45
3.4.4.	Clock/Options.....	3-46
3.4.5.	Air Data and Groundspeed	3-46
3.4.6.	Fuel Totalizer/Waypoint Distance Functions	3-47
3.4.7.	Navigation Data.....	3-48
3.4.8.	Analog Navigation Symbology	3-50
3.4.9.	Borders.....	3-51
3.4.10.	Terrain/Obstructions.....	3-52
3.4.11.	Pan Mode	3-54
3.4.12.	Start Point	3-54
3.4.13.	Direct Point.....	3-55
3.4.14.	Altitude Capture Predictor/Top-of-Descent.....	3-55
3.4.15.	Projected Path.....	3-55
3.4.16.	Active Flight Plan Path/Manual Course/Runways	3-56
3.4.16.1.	Parallel Track	3-56
3.4.16.2.	Manual Course.....	3-56

3.4.16.3.	Active Flight Plan Path.....	3-56
3.4.17.	Field of View Indication.....	3-57
3.4.18.	Range	3-57
3.5.	HSI Page.....	3-58
3.5.1.	Compass Rose Symbols	3-58
3.5.2.	Clock	3-59
3.5.3.	Air Data and Groundspeed	3-59
3.5.4.	Fuel Totalizer/Waypoint Distance Functions	3-59
3.5.5.	Conventional HSI/PTR Format	3-59
3.5.6.	HSI CDI and VDI Scale.....	3-60
3.5.7.	Analog Navigation Symbology.....	3-61
3.6.	Navigation Log.....	3-63
3.6.1.	Clock and Groundspeed	3-63
3.6.2.	Fuel Remaining and Fuel Flow Data	3-63
3.6.3.	Waypoint Identifier Column.....	3-63
3.6.4.	VNAV and VNAV Offset Column	3-64
3.6.5.	Path Column	3-64
3.6.6.	Distance Column.....	3-65
3.6.7.	Estimated Time Enroute Column.....	3-65
3.6.8.	Estimated Time of Arrival Column	3-66
3.6.9.	Fuel Remaining Column	3-66
Section 4	Reversionary Modes.....	4-1
4.1.	Reversionary Modes.....	4-1
4.1.1.	Oat Sensor Failure Mode.....	4-5
4.1.2.	Heading Failure Mode	4-5
4.1.3.	PFD Screen Auto Reversion.....	4-5
4.1.4.	OASIS EICAS Single-Action Reversion	4-6
4.1.5.	GPS Failure	4-6
4.2.	PFD and MFD Failure Mode Examples.....	4-8
4.3.	PFD Failure Mode 0.....	4-9
4.3.1.	MFD Failure Mode 0 (Normal Mode).....	4-10
4.4.	PFD Failure Mode 1.....	4-11

4.4.1.	MFD Failure Mode 1 (Normal Mode)	4-12
4.5.	PFD Failure Mode 2	4-13
4.5.1.	MFD Failure Mode 2 (Normal Mode)	4-14
4.5.2.	MFD Failure Mode 2 (Essential Mode)	4-15
4.6.	PFD Failure Mode 3	4-16
4.6.1.	MFD Failure Mode 3 (Normal Mode)	4-17
4.7.	PFD Failure Mode 4	4-18
4.7.1.	MFD Failure Mode 4 (Normal Mode)	4-19
4.7.2.	MFD Failure Mode 4 (Essential Mode)	4-20
4.8.	PFD Failure Mode 5	4-21
4.8.1.	MFD Failure Mode 5 (Normal Mode)	4-22
4.8.2.	MFD Failure Mode 5 (Essential Mode)	4-23
4.9.	PFD Failure Mode 6	4-24
4.9.1.	MFD Failure Mode 6 (Normal Mode)	4-25
4.9.2.	MFD Failure Mode 6 (Essential Mode)	4-26
4.10.	PFD Failure Mode 7	4-27
4.10.1.	MFD Failure Mode 7 (Normal Mode)	4-28
4.10.2.	MFD Failure Mode 7 (Essential Mode)	4-29
Section 5	Menu Functions and Step-By-Step Procedures	5-1
5.1.	Menu Functions.....	5-1
5.1.1.	Menu Philosophy.....	5-1
5.1.2.	Avoidance of Autonomous Behavior.....	5-2
5.2.	Menu Synchronization	5-3
5.3.	Top-Level Menu	5-6
5.3.1.	IDU-680 PFD Normal Mode Top-Level Menu.....	5-6
5.3.2.	IDU-680 MFD Normal Mode Top-Level Menu	5-7
5.3.3.	IDU-680 MFD Essential Mode Top-Level Menu	5-8
5.3.4.	Audio Radio Management Optional Page	5-9
5.3.5.	Top-Level Menu Option Descriptions.....	5-9
5.3.6.	Top-Level Menu Automatic Pop-Up Function Descriptions	5-10
5.4.	PFD Page First-Level.....	5-13

5.4.1.	PFD Page First-Level Option Descriptions.....	5-14
5.5.	First-Level (MFD).....	5-15
5.5.1.	MFD Page First-Level Option Descriptions	5-19
5.6.	Lower-Level Menus (Below First-Level)	5-19
5.6.1.	OASIS Page First-Level in Essential Mode	5-21
5.7.	Flight Plan (FPL) Menu.....	5-21
5.7.1.	Flight Planner Page	5-22
5.7.2.	Create an Overfly User Waypoint (Step-By-Step)	5-22
5.7.3.	Flight Plan (FPL) Menu Selecting (Step-By-Step)	5-23
5.7.4.	Flight Plan (FPL) Menu Create-Edit (Step-By-Step).	5-23
5.7.5.	Flight Plan (FPL) Menu Selection (Step-By-Step)	5-24
5.7.6.	Create Flight Plan (Step-By-Step)	5-24
5.7.7.	Activate Flight Plan (Step-By-Step)	5-25
5.7.8.	Edit Flight Plan (Step-By-Step).....	5-25
5.7.9.	Reverse Flight Plan (Step-By-Step).....	5-26
5.7.10.	Delete Flight Plan (Step-By-Step).....	5-27
5.7.11.	Changing Procedure in Active Flight Plan (Step-By-Step)	5-28
5.7.12.	Create User Waypoint (LAT-LON) (Step-By-Step)...	5-29
5.7.13.	Create User Waypoint (RAD-DST) (Step-By-Step) .	5-30
5.7.14.	Edit User Waypoint (Step-By-Step)	5-31
5.7.15.	Delete User Waypoint (Step-By-Step).....	5-32
5.7.16.	RAIM Prediction (Step-By-Step)	5-33
5.8.	Active Flight Plan (ACTV) Menu.....	5-35
5.8.1.	Active Flight Plan (ACTV) Menu Options	5-36
5.8.2.	Active Flight Plan (ACTV) Menu Options (Step-By- Step)	5-40
5.8.3.	Active Flight Plan (ACTV) Menu (Step-By-Step)	5-40
5.8.4.	Active Flight Plan (ACTV) Leg Management (Step-By- Step)	5-41
5.8.5.	Active Flight Plan (ACTV) NRST Menu Option (Step-By- Step)	5-42
5.9.	Information (INFO) Menu.....	5-47

- 5.9.1. Information (INFO) Menu (Step-By-Step) 5-49
- 5.10. Omnibearing Selector (OBS) Menu 5-50
 - 5.10.1. Omnibearing Selector (OBS) Menu (Step-By-Step) . 5-52
 - 5.10.2. True North and Magnetic North Menu (Step-by-Step) 5-53
- 5.11. Heading Bug (HDG) Menu..... 5-54
 - 5.11.1. Heading Bug (HDG) Menu (Step-By-Step)..... 5-54
- 5.12. Altitude Bug (ASEL) Menu 5-55
 - 5.12.1. Altitude Bug (ASEL) Menu (Step-By-Step) 5-56
- 5.13. Nearest (NRST) Menu 5-56
 - 5.13.1. Nearest (NRST) Menu (Step-By-Step) 5-58
- 5.14. Direct Menu..... 5-59
 - 5.14.1. Direct Menu (Step-By-Step)..... 5-61
- 5.15. Time Menu 5-61
 - 5.15.1. Time Menu (Step-By-Step) 5-62
- 5.16. PFD Source Menu..... 5-63
 - 5.16.1. PFD Page First-Level Source Selection (Step-By-Step) 5-64
- 5.17. PFD Bugs (BUGS) Menu 5-65
 - 5.17.1. PFD Bug (BUGS) Menu (Step-By-Step)..... 5-67
- 5.18. PFD Declutter (DCLTR) Menu 5-69
 - 5.18.1. PFD Declutter (DCLTR) Menu (Step-By-Step) 5-70
- 5.19. Altimeter Menu 5-72
 - 5.19.1. PFD Altimeter Menu (Step-By-Step)..... 5-73
- 5.20. Fault Display (FAULTS) Menu 5-74
 - 5.20.1. Fault Display (FAULTS) Menu (Step-By-Step) 5-76
- 5.21. Fuel Totalizer Quantity Setting (SET FUEL) Menu..... 5-76
- 5.22. MFD Page Menu 5-78
 - 5.22.1. MFD Page Menu (Step-By-Step) 5-78
 - 5.22.2. MFD NAV LOG Page (Step-By-Step) 5-79
- 5.23. MFD HSI Page (Step-By-Step)..... 5-79
 - 5.23.1. MFD HSI Declutter (DCLTR) Menu 5-80

5.23.1.1.	MFD HSI Declutter (DCLTR) Menu (Step-By-Step)	5-80
5.24.	MFD Page Format Menu	5-80
5.24.1.	MFD Page Format (Step-By-Step)	5-83
5.24.1.1.	Changing MFD ND Orientation.....	5-83
5.24.1.2.	Adding LAT/LON to MFD Page	5-84
Section 6	Quick Start Tutorial	6-1
Section 7	IFR Procedures.....	7-1
7.1.	Active Flight Plan	7-1
7.2.	IFR Procedures.....	7-7
7.3.	Overview of Procedures and Instrument Approaches.....	7-7
7.3.1.	Highway in the Sky (Skyway)	7-9
7.3.2.	Waypoint Sequencing.....	7-13
7.3.3.	Fly-Over Waypoints	7-14
7.3.4.	Fly-By Waypoints	7-16
7.3.5.	Direct-To	7-19
7.3.5.1.	Direct-To Unnamed Waypoints Inside Procedures	7-19
7.4.	Discontinuities.....	7-20
7.4.1.	Manual Termination Legs	7-20
7.5.	Magnetic Course.....	7-21
7.5.1.	AHRS Modes for Heading Source.....	7-21
7.5.2.	EFIS True North Mode.....	7-22
7.6.	GPS Altitude	7-22
7.7.	Dead Reckoning	7-22
7.8.	Geodesic Path Computation Accuracy	7-22
7.9.	Parallel Offsets	7-22
7.10.	Default GPS/SBAS Navigation Modes	7-25
7.11.	GPS/SBAS CDI Scale	7-27
7.11.1.	Alerting Scheme for LNAV/VNAV Procedures	7-29
7.11.2.	Alerting Scheme for LPV/LP Procedures	7-29
7.12.	Approach Type Selection.....	7-32

7.12.1.	Approach Path Definition (GPS Procedures).....	7-33
7.12.2.	VTF IFR Approach	7-33
7.12.3.	VTF VFR Approach.....	7-34
7.13.	Loss of Navigation Monitoring.....	7-34
7.13.1.	Automatic RNP Mode.....	7-34
7.13.2.	Faults Menu	7-35
7.13.3.	Loss of Integrity Caution Monitoring	7-36
7.14.	Manual Holding Patterns.....	7-37
7.15.	Selection of an Instrument Procedure	7-38
7.15.1.	Missed Approach and Departure Path Definition.....	7-38
7.15.2.	Standard Instrument Departure (DP) (Step-By-Step)	7-40
7.15.3.	Standard Terminal Arrival Route (STAR) (Step-By-Step)	7-42
7.15.4.	ILS Instrument Approach (Step-By-Step)	7-44
7.15.5.	ILS Approach with Manual Termination Leg in MAP (Step-By-Step)	7-49
7.15.6.	LOC Back Course Instrument Approach (Step-By-Step)	7-54
7.15.7.	RNAV (GPS) Instrument Approach to LP Minima (Step-By-Step)	7-60
7.15.8.	RNAV (GPS) Instrument Approach to LPV Minima (Step-By-Step)	7-65
7.15.9.	RNAV (RNP) Instrument Approach to RNP 0.11 DA (Step-By-Step)	7-72
7.15.10.	NRST ILS Instrument Approach (Step-By-Step)	7-76
7.15.11.	VOR/DME Instrument Approach (Step-By-Step).....	7-81
7.15.12.	LDA Instrument Approach (Step-By-Step).....	7-86
7.15.13.	ILS or LOC RWY 1 Instrument Approach with Missed Approach Flown to Alternate Fix (Step-By-Step).....	7-89
Section 8	Terrain Awareness Warning System	8-1
8.1.	Terrain Awareness Warning System (TAWS) Functions.....	8-1
8.2.	Terrain Display	8-2
8.3.	Forward Looking Terrain Alert (FLTA) Function	8-3
8.3.1.	FLTA Modes.....	8-3

8.3.2.	GPS/SBAS Navigation Mode Slaving.....	8-3
8.3.3.	Default FLTA Mode.....	8-4
8.3.4.	FLTA Search Envelope.....	8-5
8.3.5.	FLTA Alerts and Automatic Popup	8-8
8.4.	Premature Descent Alert (PDA) Function.....	8-9
8.5.	Excessive Rate of Descent (GPWS Mode 1)	8-10
8.6.	Excessive Closure Rate to Terrain (GPWS Mode 2)	8-11
8.7.	Sink Rate after Takeoff or Missed Approach (GPWS Mode 3)	8-13
8.8.	Flight into Terrain when not in Landing Configuration (GPWS Mode 4)	8-13
8.9.	Excessive Downward Deviation from an ILS Glideslope (GPWS Mode 5)	8-15
8.10.	500-Foot Wake-Up Call	8-16
8.11.	External Sensors and Switches	8-16
8.12.	TAWS Basic Parameter Determination	8-17
8.13.	TAWS Automatic Inhibit Functions (Normal Operation)	8-20
8.13.1.	TAWS Automatic Inhibit Functions (Abnormal Operation)	8-20
8.13.2.	TAWS Manual Inhibit Functions	8-23
8.14.	TAWS Selections on PFD.....	8-23
Section 9	Appendix.....	9-1
9.1.	Appendix.....	9-1
9.2.	Operating Tips	9-1
9.3.	Domestic or International Flight Planning.....	9-1
9.4.	Descent Planning.....	9-1
9.5.	Terrain Clearance	9-1
9.6.	Departure Airport Information	9-2
9.7.	Unique Names for Flight Plans	9-2
9.8.	Altimeter Settings.....	9-2
9.9.	Warnings, Cautions, and Advisories.....	9-2
9.10.	Magnetic vs. True North Modes of Operation.....	9-2
9.11.	Altitude Miscompare Threshold	9-4

9.12.	Airspeed Miscompare Threshold	9-5
9.13.	Jeppesen Sanderson NavData® Chart Compatibility.....	9-6
9.14.	ARINC 424 Path-Terminator Leg Types	9-6
9.15.	Data Logging and Retrieval	9-6
9.15.1.	Delete Log Files	9-7
9.15.2.	Logged Flags and Custom CAS Messages.....	9-7
9.16.	Routes and Waypoints	9-8
9.16.1.	VFR Flight Planning	9-8
9.16.2.	Download Routes and User Waypoints	9-8
9.16.3.	Upload Routes and User Waypoints.....	9-8
9.16.4.	Delete Routes	9-9
9.17.	Summary of Asterisk Symbology in Pilot Guide	9-9
9.18.	Changing Instrument Approach Procedure at Same Airport	9-10
9.19.	Use of NRST ILS Feature as Shortcut to Full ILS Procedure	9-11
9.20.	EFIS NAV Source Management	9-12
9.21.	EFIS Training Tool (ETT).....	9-15
9.22.	USB Flash Drive Memory Limitations	9-16
9.23.	Certification Basis	9-17
9.24.	Environmental Requirements.....	9-17
T 1.	Traffic Page Access	T-1
T 2.	Menu Declutter.....	T-1
T 3.	Traffic Symbology	T-3
T 3.1.	Traffic Display Definitions	T-4
T 3.2.	Traffic Rendering Rules	T-5
T 3.3.	Traffic Thumbnail	T-5
T 4.	Dedicated Traffic Page	T-6
T 4.1.	MFD Page (PAGE) Menu	T-6
T 4.2.	Traffic Display Format.....	T-6
T 4.3.	Traffic Page Screen Range.....	T-6
T 4.4.	Compass Rose Symbols.....	T-7
T 4.5.	Clock and Options.....	T-7
T 4.6.	Fuel Totalizer/Waypoint Distance Functions	T-8

T 4.7.	Active Flight Plan Path/Manual Course/Runways	T-8
T 5.	MFD Traffic Format Menu.....	T-9
T 6.	Fault Display (FAULTS) Menu.....	T-10
T 7.	Menu Synchronization	T-10
RBP 1.	Remote Bugs Panel.....	RBP-1
S 1.	WX-500 Data	S-1
S 2.	Dedicated Strikes Page	S-2
S 2.1.	MFD Page (PAGE) Menu	S-2
S 2.1.1.	MFD STRIKES Page (Step-By-Step)	S-2
S 2.2.	Page Screen Range	S-2
S 2.3.	Air Data and Groundspeed	S-2
S 2.4.	Clock and Options	S-3
S 2.5.	Active Flight Plan Path/Manual Course/Runways	S-3
S 2.6.	Fuel Totalizer/Waypoint Distance Functions	S-4
S 3.	MFD Faults Display (FAULTS) Menu	S-4
S 4.	MFD Page First-Level Option Descriptions	S-4
S 5.	MFD Strikes Format (FORMAT) Menu	S-4
S 6.	Menu Synchronization	S-5
D 1.	Datalink Symbology	D-1
D 2.	Dedicated Datalink Page	D-4
D 2.1.	MFD Page Menu.....	D-4
D 2.2.	Ownship Symbol.....	D-4
D 2.3.	Datalink Page Legend	D-4
D 2.4.	Air Data and Groundspeed	D-4
D 2.5.	Clock and Options	D-4
D 2.6.	Datalink Page Screen Orientation	D-6
D 2.7.	Boundary Circle Symbols	D-7
D 2.8.	Active Flight Plan Path/Manual Course/Runways	D-7
D 2.9.	Borders	D-8
D 2.10.	Pan Mode.....	D-8
D 3.	MFD Datalink Format Menu.....	D-9
D 3.1.	MFD DATALINK Page (Step-By-Step)	D-9

D 4.	Top-Level Menu Automatic Pop-Up Function Descriptions ..	D-10
D 5.	MFD Page First-Level Option Descriptions	D-11
D 6.	Active Flight Plan (ACTV) Menu Options.....	D-11
D 7.	Information (INFO) Menu	D-11
D 8.	MFD Fault Display Menu	D-11
D 9.	Menu Synchronization	D-12
WX 1.	Weather Radar.....	WX-1
WX 2.	Top-Level Menu Option Descriptions.....	WX-3
WX 3.	PFD Weather Radar Page Format Menu	WX-3
WX 3.1.	Weather Page Screen Range	WX-8
WX 3.2.	Track Line	WX-8
WX 3.3.	Active Flight Plan Path/Manual Course/Runways ..	WX-9
WX 3.4.	Weather Radar Return Data	WX-10
WX 3.5.	Air Data and Groundspeed	WX-11
WX 3.6.	Waypoint Distance	WX-11
WX 3.7.	Clock/Options.....	WX-11
WX 3.8.	Fuel Totalizer/Waypoint Distance Functions	WX-13
WX 4.	MFD Fault Display (FAULTS) Menu	WX-13
WX 5.	Managing RDR-2100 Weather Radar Menus (PFD) (Step-By-Step)	WX-14
WX 6.	Managing RDR-2100 Weather Radar Menus (MFD) (Top Area) (Step-By-Step).....	WX-19
WX 7.	Managing RDR-2100 Weather Radar Menus (MFD) (BTM area) (Step-By-Step)	WX-24
WX 8.	Managing RDR-2000 Weather Radar Menus (PFD) (Step-By-Step)	WX-31
WX 9.	Managing RDR-2000 Weather Radar Menus (MFD) (Step-By-Step)	WX-33
WX 10.	Menu Synchronization	WX-33
V 1.	Video Input Page.....	V-1
V 1.1.	PFD Page First-Level Option Descriptions	V-1
V 1.2.	Top-Level Menu Option Descriptions.....	V-2
V 1.3.	MFD Page First-Level Option Descriptions	V-2
V 1.4.	Pan Mode	V-4

V 2.	Video Input Status Display.....	V-4
V 3.	Menu Synchronization	V-5
RD 1.	PFD Primary Flight Instrumentation	RD-1
RD 1.1.	Pitch Scale	RD-1
RD 1.2.	Flight Director Symbolology.....	RD-1
RD 1.3.	Marker Beacon Indicators	RD-2
RD 1.4.	Unusual Attitude Mode	RD-2
RD 1.5.	Bank Angle Scale	RD-3
RD 1.6.	Pitch Limit Indicator	RD-3
RD 1.7.	AGL Indication	RD-4
RD 1.8.	Landing Gear Indication.....	RD-5
RD 1.9.	Airspeed Display.....	RD-6
RD 1.9.1	Airspeed Readout	RD-7
RD 1.9.2	Takeoff and Landing Speed Bugs	RD-8
RD 1.10.	Altimeter.....	RD-9
RD 1.11.	Altitude Display	RD-10
RD 1.11.1	Loss of ADC Sensor Indication	RD-11
RD 1.11.2	Altitude Sub-Mode	RD-11
RD 1.11.3	Metric Altitude.....	RD-12
RD 1.12.	Vertical Speed Indicator.....	RD-12
RD 1.13.	Heading Display.....	RD-14
RD 1.14.	Heading Failure Mode	RD-15
RD 1.15.	G-Force Indicator	RD-15
RD 1.16.	Turn Rate Indicator	RD-16
RD 1.17.	Timer Indication	RD-16
RD 1.18.	Vertical Deviation Indicator (VDI).....	RD-17
RD 1.19.	Course Deviation Indicator	RD-19
RD 1.20.	Vertical Deviation Indicator (EFIS Coupled)	RD-22
RD 1.21.	Active Waypoint and Waypoint Identifier	RD-22
RD 2.	GPS Failure	RD-23
RD 3.	Red-X (Invalid Input).....	RD-24
RD 4.	PFD Failure Mode 0.....	RD-25

RD 4.1.	PFD Failure Mode 1	RD-26
SAR 1.	Search and Rescue (SAR) Patterns	SAR-1
SAR 1.1.	SAR Pattern Step-by-Step Procedures.....	SAR-1
SAR 2.	Expanding Square Pattern.....	SAR-4
SAR 3.	Rising Ladder Pattern	SAR-6
SAR 4.	Orbit Pattern.....	SAR-7
SAR 5.	Race Track Pattern	SAR-8
SAR 6.	Sector Search Pattern.....	SAR-9
INDEX		
GLOSSARY		

List of Figures and Tables

FIGURE 1-1: IDU-680 INPUT IDENTIFICATION.....	1-1
TABLE 2-1: PERTINENT EFIS LIMITS SETTINGS.....	2-12
FIGURE 2-1: IDU-680 PRIMARY FLIGHT DISPLAY (PFD) WITH PFI AND NAVIGATIONAL DISPLAY (ND) MAP PAGE	2-15
FIGURE 2-2: IDU-680 MULTIFUNCTION DISPLAY (MFD).....	2-16
FIGURE 2-3: SYSTEM DIAGRAM.....	2-17
FIGURE 2-4: IDU-680 INITIALIZATION SCREEN.....	2-17
TABLE 2-2: IDU SOFTWARE VERSION AND PART NUMBER.....	2-18
TABLE 2-3: IDU NUMBER DESIGNATION	2-18
FIGURE 2-5: LOGO SCREEN WITH “TESTING”	2-20
FIGURE 2-6: CRC SCREEN.....	2-21
FIGURE 2-7: TWO-MINUTE COUNTDOWN SCREEN.....	2-21
FIGURE 2-8: QUICK START SCREEN	2-22
FIGURE 2-9: PFD PFI ON TOP AND MAP ON BOTTOM.....	2-23
FIGURE 2-10: PFD NORMAL MODE	2-24
FIGURE 2-11: MFD NORMAL MODE	2-25
TABLE 2-4: COLOR CONVENTIONS	2-26
FIGURE 2-12: TIME-CRITICAL WARNING AND CAUTION ALERTS	2-29
TABLE 2-5: TIME-CRITICAL WARNING AND CAUTION ALERTS IN PRIMARY FIELD OF VIEW.....	2-29
TABLE 2-6: TIME-CRITICAL WARNING AND CAUTION ALERTS	2-30
FIGURE 2-13: WARNING ALERTS.....	2-32
TABLE 2-7: WARNING ALERT ELEMENTS.....	2-32
TABLE 2-8: WARNING ALERTS.....	2-32
FIGURE 2-14: CAUTION ALERTS.....	2-33
TABLE 2-9: CAUTION ALERT ELEMENTS.....	2-33
TABLE 2-10: CAUTION ALERTS.....	2-34
TABLE 2-11: SIDE-SPECIFIC CAUTION ALERTS.....	2-40
FIGURE 2-15: ADVISORY ALERTS	2-40
TABLE 2-12: ADVISORY ALERT ELEMENTS.....	2-40
TABLE 2-13: ADVISORY ALERTS.....	2-41
TABLE 2-14: SIDE-SPECIFIC ADVISORY ALERTS.....	2-42
TABLE 2-15: AUDIO-ONLY CAUTION AND ADVISORY ALERTS	2-45
FIGURE 2-16: GROUND MAINTENANCE PAGE.....	2-49
FIGURE 3-1: PFD NORMAL SVS MODE	3-1
FIGURE 3-2: PFD IN BASIC MODE	3-2
FIGURE 3-3: MFD IN NORMAL MODE WITH MAP PAGE DISPLAYED ON TOP AND HSI ON BOTTOM	3-3
FIGURE 3-4: MFD IN ESSENTIAL MODE	3-4
FIGURE 3-5: MFD IN NORMAL MODE.....	3-5
FIGURE 3-6: MENU FUNCTIONS.....	3-5
FIGURE 3-7: ENCODER FUNCTIONS	3-6
FIGURE 3-8: MENU MANAGEMENT.....	3-6
FIGURE 3-9: PFD SYMBOLOGY	3-6

FIGURE 3-10: ALTITUDE DISPLAY.....	3-7
FIGURE 3-11: ALTITUDE DISPLAY (METRIC UNITS).....	3-7
FIGURE 3-12: SELECTING ALTIMETER SETTING	3-8
FIGURE 3-13: ALTIMETER SETTING	3-8
FIGURE 3-14: TARGET ALTITUDE	3-8
FIGURE 3-15: TARGET ALTITUDE BUG (VERTICALLY INTEGRATED WITH AUTOPILOT).....	3-9
FIGURE 3-16: TARGET ALTITUDE BUG (WITH OR WITHOUT AUTOPILOT)	3-9
FIGURE 3-17: ALTITUDE DISPLAY (VNAV TILE)	3-9
FIGURE 3-18: VNAV SUB-MODE (NOT VERTICALLY INTEGRATED).....	3-10
FIGURE 3-19: VNAV SUB-MODE WITH GENESYS/S-TEC DFCS	3-10
FIGURE 3-20: MINIMUM ALTITUDE.....	3-11
FIGURE 3-21: VSI.....	3-11
FIGURE 3-22: VSI BUG	3-11
TABLE 3-1: SCALE GRADUATIONS AND DISPLAY	3-11
FIGURE 3-23: VSI BUG WITHOUT GENESYS/S-TEC DFCS	3-12
FIGURE 3-24: VSI BUG WITH GENESYS/S-TEC DFCS	3-12
FIGURE 3-25: NORMAL AGL INDICATION	3-12
TABLE 3-2: AGL INDICATION.....	3-12
FIGURE 3-26: ANALOG AGL INDICATION	3-13
TABLE 3-3: ANALOG AGL INDICATOR	3-13
TABLE 3-4: ANALOG AGL INDICATOR MARKINGS	3-13
FIGURE 3-27: DECISION HEIGHT	3-14
FIGURE 3-28: AIRSPEED DISPLAY	3-14
TABLE 3-5: AIRSPEED BUG LIMITS	3-15
TABLE 3-6: AIRSPEED BUG SETTING ANNUNCIATION AND BUG COLORS.....	3-15
FIGURE 3-29: AIRSPEED TREND	3-15
FIGURE 3-30: AIRSPEED BUG OFF SCALE	3-15
FIGURE 3-31: AIRSPEED SCALE FAR PART 23.....	3-16
FIGURE 3-32: AIRSPEED SCALE FAR PART 25.....	3-17
FIGURE 3-33: AIRSPEED DISPLAY (WITH EFIS-COUPLED).....	3-18
FIGURE 3-34: HEADING DISPLAY	3-19
FIGURE 3-35: DAMPENED INTEGRAL SLIP INDICATOR.....	3-19
TABLE 3-7: HEADING DISPLAY	3-19
FIGURE 3-36: DG INDICATED WHEN AHRS IN DG MODE	3-20
FIGURE 3-37: GPS LOSS OF NAVIGATION (LON)	3-20
FIGURE 3-38: PITCH SCALE	3-20
FIGURE 3-39: PITCH SCALE ZENITH AND NADIR SYMBOL	3-20
FIGURE 3-40: PITCH LIMIT INDICATOR (20 KNOTS ABOVE STALL).....	3-21
FIGURE 3-41: PITCH LIMIT INDICATOR (5 KNOTS ABOVE STALL).....	3-22
FIGURE 3-42: TURN INDICATION (SELECTED FROM DECLUTTER MENU)	3-22
FIGURE 3-43: G-FORCE INDICATOR	3-22
FIGURE 3-44: G-FORCE INDICATOR TELLTALE INDICATIONS	3-22
FIGURE 3-45: ANALOG G-FORCE INDICATOR.....	3-23
FIGURE 3-46: RESET G	3-23
FIGURE 3-47: LANDING GEAR INDICATION	3-23

FIGURE 3-48: UNUSUAL ATTITUDE MODE	3-23
FIGURE 3-49: PFD TERRAIN AND OBSTRUCTIONS	3-25
TABLE 3-8: LAT-LON RESOLUTION BOUNDARIES	3-26
TABLE 3-9: TERRAIN AND OBSTRUCTION RENDERING LEVELS	3-26
FIGURE 3-50: PFD WITH TERRAIN Deselected BUT RETAINED ON MAP ...	3-27
FIGURE 3-51: PFD WITH OBSTRUCTIONS	3-28
FIGURE 3-52: FLIGHT PATH MARKER	3-28
FIGURE 3-53: FLIGHT PATH MARKER VIEWS	3-29
TABLE 3-10: FLIGHT PATH MARKER BEHAVIOR	3-29
FIGURE 3-54: FLIGHT PATH MARKER GHOST	3-30
FIGURE 3-55: FLIGHT PATH MARKER ABSENCE	3-30
FIGURE 3-56: BANK ANGLE	3-30
FIGURE 3-57: TIMER.....	3-31
FIGURE 3-58: MARKER BEACONS.....	3-31
FIGURE 3-59: FLIGHT DIRECTOR FD1 SINGLE CUE.....	3-31
FIGURE 3-60: FLIGHT DIRECTOR FD1 (BASIC MODE WITH COMPASS ROSE DETECTED ON MFD PAGE).....	3-32
FIGURE 3-61: FLIGHT DIRECTOR FD2 (NORMAL MODE).....	3-32
FIGURE 3-62: FLIGHT DIRECTOR FD2 (BASIC MODE WITHOUT COMPASS ROSE DETECTED ON MFD PAGE).....	3-33
FIGURE 3-63: COURSE DEVIATION INDICATOR	3-33
TABLE 3-11: CDI BEHAVIOR AND COLOR.....	3-34
FIGURE 3-64: CDI NO AUTOPILOT OR FULLY-INTEGRATED AUTOPILOT	3-36
FIGURE 3-65: VERTICAL DEVIATION INDICATOR	3-36
FIGURE 3-66: VDI COLOR DURING GPS/SBAS LON OR VLON	3-37
TABLE 3-12: VERTICAL DEVIATION INDICATOR BEHAVIOR	3-37
FIGURE 3-67: EFIS COUPLED VERTICALLY WITH GLIDESLOPE MODE.....	3-38
FIGURE 3-68: HIGHWAY IN THE SKY	3-39
FIGURE 3-69: ACTIVE WAYPOINT	3-39
FIGURE 3-70: MINI MAP.....	3-40
TABLE 3-13: MINI MAP BEHAVIOR (WHEN NOT DECLUTTERED)	3-41
FIGURE 3-71: RUNWAYS.....	3-41
TABLE 3-14: RUNWAY DRAWING CRITERIA	3-42
FIGURE 3-72: OWNERSHIP SYMBOLS	3-43
FIGURE 3-73: BASIC MOVING MAP	3-43
FIGURE 3-74: MOVING MAP WITH INSTRUMENT APPROACH WITH HSI ENABLED	3-44
FIGURE 3-75: NORTH-UP ARC MODE WITH HSI ENABLED AND VOR1 SELECTED	3-44
FIGURE 3-76: NORTH-UP CENTERED MODE WITH HSI ENABLED AND VLOC1 SELECTED	3-45
FIGURE 3-77: HEADING-UP CENTERED MODE	3-45
FIGURE 3-78: COMPASS ROSE/ND BOUNDARY CIRCLE SYMBOL	3-45
TABLE 3-15: CLOCK OPTIONS.....	3-46
FIGURE 3-79: CLOCK OPTIONS	3-46
FIGURE 3-80: AIR DATA AND GROUNDSPED.....	3-46

FIGURE 3-81: FUEL TOTALIZER/WAYPOINT DISTANCE FUNCTIONS	3-47
TABLE 3-16: FUEL TOTALIZER/WAYPOINT DISTANCE FUNCTIONS	3-47
FIGURE 3-82: NAVIGATION DATA AND AIRSPACE DEPICTION	3-48
TABLE 3-17: NAVIGATION SYMBOLOGY	3-49
TABLE 3-18: AIRSPACE DEPICTION	3-49
FIGURE 3-83: ANALOG NAVIGATION SYMBOLOGY, HSI IN ARC MODE	3-50
FIGURE 3-84: ANALOG NAVIGATION SYMBOLOGY, HSI IN CENTERED MODE	3-51
FIGURE 3-85: WITH INTERNATIONAL AND STATE BORDERS	3-51
FIGURE 3-86: WITHOUT INTERNATIONAL AND STATE BORDERS	3-52
FIGURE 3-87: TERRAIN AND OBSTRUCTIONS	3-52
TABLE 3-19: TERRAIN COLOR.....	3-53
TABLE 3-20: OBSTRUCTIONS.....	3-53
FIGURE 3-88: PAN MODE	3-54
FIGURE 3-89: START POINT.....	3-54
FIGURE 3-90: DIRECT POINT	3-55
FIGURE 3-91: TOP-OF-DESCENT OR TOP-OF-CLIMB	3-55
FIGURE 3-92: PROJECTED PATH.....	3-56
FIGURE 3-93: PARALLEL TRACK.....	3-56
FIGURE 3-94: GPS/SBAS OBS MANUAL	3-57
FIGURE 3-95: FIELD OF VIEW.....	3-57
FIGURE 3-96: RANGE.....	3-58
FIGURE 3-97: HSI PAGE	3-58
FIGURE 3-98: COMPASS ROSE	3-58
FIGURE 3-99: HSI CLOCK	3-59
FIGURE 3-100: HSI DISPLAY AIR DATA AND GROUND SPEED	3-59
FIGURE 3-101: HSI FUEL TOTALIZER/WAYPOINT FUNCTIONS.....	3-59
FIGURE 3-102: HSI POINTER COLOR.....	3-60
FIGURE 3-103: CDI SCALE WITH VDI.....	3-60
FIGURE 3-104: ANALOG NAVIGATION DISPLAY VOR1 AND VOR2	3-61
FIGURE 3-105: ANALOG NAVIGATION DISPLAY FMS AND ADF2.....	3-61
FIGURE 3-106: HSI BEARING DISTANCE READOUT WITH DME IN HOLD ...	3-62
FIGURE 3-107: HSI WITH MARKER BEACON DISPLAYED.....	3-62
FIGURE 3-108: NAVIGATION LOG	3-63
TABLE 4-1: PFD FUNCTIONS	4-2
TABLE 4-2: MFD FUNCTIONS.....	4-3
TABLE 4-3: OUTPUT FUNCTIONS.....	4-3
FIGURE 4-1: OAT SENSOR FAIL	4-5
FIGURE 4-2: GPS TRK	4-5
FIGURE 4-3: LOSS OF INTEGRITY (LOI)	4-6
FIGURE 4-4: FAULTS PAGE ON MFD.....	4-7
FIGURE 4-5: DEAD RECKONING	4-7
FIGURE 4-6: LOSS OF VERTICAL NAVIGATION (VLON).....	4-8
FIGURE 4-7: PFD FAILURE MODE 0 GPS, ADC AND AHRS NORMAL.....	4-9
FIGURE 4-8: MFD FAILURE MODE 0 (NORMAL MODE) GPS, ADC AND AHRS NORMAL	4-10

FIGURE 4-9: PFD FAILURE MODE 1 GPS/SBAS FAILED, ADC AND AHRS NORMAL	4-11
FIGURE 4-10: MFD FAILURE MODE 1 (NORMAL MODE) GPS/SBAS FAILED, ADC AND AHRS NORMAL	4-12
FIGURE 4-11: PFD MODE 2 ADC FAILED, GPS/SBAS AND AHRS NORMAL... ..	4-13
FIGURE 4-12: MFD FAILURE MODE 2 (NORMAL MODE) ADC FAILED, GPS/SBAS AND AHRS NORMAL	4-14
FIGURE 4-13: MFD FAILURE MODE 2 (ESSENTIAL MODE) ADC FAILED, GPS/SBAS AND AHRS NORMAL	4-15
FIGURE 4-14: PFD FAILURE MODE 3 AHRS FAILED, GPS/SBAS AND ADC NORMAL	4-16
FIGURE 4-15: MFD FAILURE MODE 3 (NORMAL MODE) AHRS FAILED, GPS/SBAS AND ADC NORMAL	4-17
FIGURE 4-16: PFD FAILURE MODE 4 GPS/SBAS AND ADC FAILED, AHRS NORMAL	4-18
FIGURE 4-17: MFD FAILURE MODE 4 (NORMAL MODE) GPS/SBAS AND ADC FAILED, AHRS NORMAL	4-19
FIGURE 4-18: MFD FAILURE MODE 4 (ESSENTIAL MODE) GPS/SBAS AND ADC FAILED, AHRS NORMAL	4-20
FIGURE 4-19: PFD FAILURE MODE 5 GPS/SBAS AND AHRS FAILED, ADC NORMAL	4-21
FIGURE 4-20: MFD FAILURE MODE 5 (NORMAL MODE) GPS/SBAS AND AHRS FAILED, ADC NORMAL.....	4-22
FIGURE 4-21: MFD FAILURE MODE 5 (ESSENTIAL MODE) GPS/SBAS AND AHRS FAILED, ADC NORMAL.....	4-23
FIGURE 4-22: PFD FAILURE MODE 6 ADC AND AHRS FAILED, GPS/SBAS NORMAL	4-24
FIGURE 4-23: MFD FAILURE MODE 6 (NORMAL MODE) ADC AND AHRS FAILED, GPS/SBAS NORMAL.....	4-25
FIGURE 4-24: MFD FAILURE MODE 6 (ESSENTIAL MODE) ADC AND AHRS FAILED, GPS/SBAS NORMAL.....	4-26
FIGURE 4-25: PFD FAILURE MODE 7 GPS/SBAS, ADC AND AHRS FAILED.... ..	4-27
FIGURE 4-26: MFD FAILURE MODE 7 (NORMAL MODE) GPS/SBAS, ADC AND AHRS FAILED.....	4-28
FIGURE 4-27: MFD FAILURE MODE 7 (ESSENTIAL MODE) GPS/SBAS, ADC AND AHRS FAILED	4-29
FIGURE 5-1: IDU-680 INPUT CONTROLS	5-1
FIGURE 5-2: INDICATION OF FURTHER MENU LEVELS	5-2
TABLE 5-1: MENU SYNCHRONIZATION	5-3
FIGURE 5-3: PFD TOP-LEVEL MENU (NORMAL MODE).....	5-6
FIGURE 5-4: MFD TOP-LEVEL MENU (NORMAL MODE)	5-7
FIGURE 5-5: MFD TOP-LEVEL MENU (ESSENTIAL MODE).....	5-8
FIGURE 5-6: PFD OR MFD ESSENTIAL MODE TOP-LEVEL MENU WITH AUDIO RADIO MANAGEMENT OPTION	5-9

TABLE 5-2: TOP-LEVEL AUTO POP-UP FUNCTION DESCRIPTIONS.....	5-11
FIGURE 5-7: PFD PAGE FIRST-LEVEL.....	5-13
TABLE 5-3: CROSSFILL INHIBIT/ARM/SYNC FUNCTION.....	5-14
FIGURE 5-8: FIRST-LEVEL MFD.....	5-16
FIGURE 5-9: FIRST-LEVEL (PFD IDU #1) (PFI IN TOP AREA AND MFD IN BOTTOM AREA) (NORMAL MODE)	5-17
FIGURE 5-10: FIRST-LEVEL (MFD IDU #2) WITH AN MFD PAGE IN BOTH AREAS (NORMAL MODE).....	5-18
FIGURE 5-11: PFD PAGE IN TOP AREA AND ESSENTIAL MODE OASIS PAGE IN BOTTOM AREA.....	5-20
FIGURE 5-12: FLIGHT PLAN MENU (PFD OR MFD).....	5-21
FIGURE 5-13: SELECT FROM OPTION LIST.....	5-21
FIGURE 5-14: ACTIVE FLIGHT PLAN MAIN MENU.....	5-35
FIGURE 5-15: ACTIVE FLIGHT PLAN MENU OPTIONS.....	5-36
TABLE 5-4: ACTIVE FLIGHT PLAN MENU OPTIONS.....	5-37
FIGURE 5-16: INFORMATION MENU.....	5-47
TABLE 5-5: INFO MENU INFORMATION.....	5-48
FIGURE 5-17: REMOTE TUNING NAV RADIOS.....	5-48
FIGURE 5-18: REMOTE TUNING COM RADIOS.....	5-49
FIGURE 5-19: CRS SYNC.....	5-49
FIGURE 5-20: OMNIBEARING SELECTOR (OBS) MENU.....	5-50
TABLE 5-6: OMNIBEARING SELECTOR (OBS) MENU OPTIONS.....	5-51
FIGURE 5-21: HEADING BUG (HDG) MENU.....	5-54
FIGURE 5-22: ALTITUDE BUG (ASEL) MENU.....	5-56
FIGURE 5-23: NEAREST (NRST) MENU.....	5-57
FIGURE 5-24: DIRECT MENU.....	5-60
FIGURE 5-25: TIME MENU.....	5-62
FIGURE 5-26: PFD SOURCE MENU.....	5-63
FIGURE 5-27: AHRS SLAVE/AHRS SLEW.....	5-64
FIGURE 5-28: PFD BUGS (BUGS) MENU.....	5-65
FIGURE 5-29: PFD BUGS (BUGS) MENU (CONTINUED).....	5-66
FIGURE 5-30: PFD DECLUTTER (DCLTR) MENU.....	5-69
TABLE 5-7: PFD DECLUTTER OPTIONS.....	5-70
FIGURE 5-31: ALTIMETER MENU.....	5-72
FIGURE 5-32: MFD FAULT DISPLAY MENU.....	5-74
FIGURE 5-33: FUEL TOTALIZER QUANTITY MENU.....	5-76
FIGURE 5-34: PFD/MFD SET FUEL.....	5-76
FIGURE 5-35: FUEL TOTALIZER QUANTITY SETTING (SET FUEL) MENU.....	5-77
FIGURE 5-36: MFD PAGE (PAGE) MENU.....	5-78
FIGURE 5-37: MFD HSI DCLTR MENU.....	5-80
FIGURE 5-38: MFD SYMBOL DECLUTTER.....	5-81
FIGURE 5-39: MFD PAGE FORMAT MENU.....	5-82
TABLE 7-1: VNAV ALTITUDES AND OFFSETS.....	7-2
FIGURE 7-1: SUPPRESSED WAYPOINT.....	7-2
FIGURE 7-2: ACTIVE FLIGHT PLAN WITH TWO SUPPRESSED WAYPOINTS.....	7-3
TABLE 7-2: HIGHWAY IN THE SKY CONFIGURATION.....	7-9

FIGURE 7-3: HIGHWAY IN THE SKY (AIRCRAFT REFERENCED).....	7-11
FIGURE 7-4: HIGHWAY IN THE SKY (GEO-REFERENCED BACKWARD)	7-11
FIGURE 7-5: HIGHWAY IN THE SKY (GEO-REFERENCED FORWARD)	7-11
TABLE 7-3: FINAL SEGMENT OF IFR APPROACH, DESCENT ANGLE AND VNAV WAYPOINT	7-12
FIGURE 7-6: HIGHWAY IN THE SKY FINAL APPROACH SEGMENTS.....	7-13
FIGURE 7-7: FLY-OVER WAYPOINTS	7-14
TABLE 7-4: RNAV PATH TERMINATOR LEG TYPE	7-15
FIGURE 7-8: FLY-BY WAYPOINTS.....	7-16
TABLE 7-5: LEG SEGMENTS FOR PATHS CONSTRUCTED BY EFIS	7-17
FIGURE 7-9: UNNAMED WAYPOINTS	7-19
FIGURE 7-10: PARALLEL OFFSET PTK-/PTK ENTRY	7-23
FIGURE 7-11: PARALLEL OFFSET PTK-/PTK ENDING	7-24
TABLE 7-6: PARALLEL OFFSETS SYMBOLS AND DESCRIPTION.....	7-25
TABLE 7-7: DEFAULT GPS/SBAS NAVIGATION MODES.....	7-26
TABLE 7-8: DEFAULT NAVIGATION MODES BASED UPON REGION OF OPERATION	7-26
TABLE 7-9: SUMMARY OF CHANGES IN CROSS-TRACK FSD	7-27
TABLE 7-10: SUMMARY OF TYPICAL MODE SWITCHING TRANSITIONS.....	7-28
FIGURE 7-12: VERTICAL DEVIATION INDICATOR LINEAR DEVIATION.....	7-29
FIGURE 7-13: FSD LATERAL DEVIATION INDICATOR LINEAR DEVIATION (NOT VTF APPROACH).....	7-30
FIGURE 7-14: FSD LATERAL DEVIATION INDICATOR LINEAR DEVIATION VTF APPROACH.....	7-31
FIGURE 7-15: VTF VFR APPROACH.....	7-34
FIGURE 7-16: LON INDICATION.....	7-35
TABLE 7-11: SUMMARY OF FAULTS MENU	7-35
TABLE 7-12: LOSS OF INTEGRITY CAUTION MONITORING.....	7-36
FIGURE 7-17: MISSED APPROACH AND DEPARTURE PATH.....	7-39
FIGURE 7-18: STANDARD INSTRUMENT DEPARTURE (DP)	7-40
FIGURE 7-19: STANDARD TERMINAL ARRIVAL ROUTE (STAR).....	7-42
FIGURE 7-20: ILS INSTRUMENT APPROACH (KSNA).....	7-44
FIGURE 7-21: ILS APPROACH (EGYD).....	7-49
FIGURE 7-22: LOC BACK COURSE APPROACH	7-54
FIGURE 7-23: RNAV (GPS) INSTRUMENT APPROACH TO LP MINIMA.....	7-60
FIGURE 7-24: RNAV (GPS) INSTRUMENT APPROACH TO LPV MINIMA	7-65
FIGURE 7-25: RNAV (RNP) INSTRUMENT APPROACH TO RNP 0.11 DA...	7-72
FIGURE 7-26: NRST ILS INSTRUMENT APPROACH	7-76
FIGURE 7-27: VOR/DME INSTRUMENT APPROACH.....	7-81
FIGURE 7-28: LDA Y RWY 19 INSTRUMENT APPROACH	7-86
FIGURE 7-29: ILS OR LOC RWY 1 INSTRUMENT APPROACH WITH MISSED APPROACH FLOWN TO ALTERNATE FIX (STEP-BY-STEP)	7-89
TABLE 8-1: TAWS FUNCTIONS PROVIDED BY THE EFIS.....	8-1
FIGURE 8-1: TERRAIN DISPLAY	8-2
FIGURE 8-2: FLTA INHBT	8-3
FIGURE 8-3: DEFAULT FLTA INHBT	8-4

FIGURE 8-4: FLTA INHBT MODE AREAS	8-5
TABLE 8-2: FLTA SEARCH ENVELOPE	8-5
FIGURE 8-5: FLTA SEARCH VOLUME	8-7
FIGURE 8-6: MAP IN POPUP MODE.....	8-8
FIGURE 8-7: PDA ALERT THRESHOLD.....	8-10
TABLE 8-3: GPWS MODE 1 ENVELOPE.....	8-10
FIGURE 8-8: FIXED WING GPWS MODE 1.....	8-11
TABLE 8-4: GPWS MODE 2 ENVELOPES.....	8-11
TABLE 8-5: GPWS MODE 2A ENVELOPES (NOT IN LANDING CONFIGURATION)	8-12
TABLE 8-6: GPWS MODE 2B ENVELOPES (LANDING CONFIGURATION)	8-12
FIGURE 8-9: FIXED WING GPWS MODE 2.....	8-12
FIGURE 8-10: GPWS MODE 3 WARNING (SINK RATE AFTER TAKEOFF OR MISSED APPROACH).....	8-13
FIGURE 8-11: FIXED WING GPWS MODE 3.....	8-13
TABLE 8-7: MODE 4 ENVELOPES.....	8-14
TABLE 8-8: GPWS MODE 4 ALERTING CRITERIA	8-14
TABLE 8-9: GPWS MODE 4 PARAMETERS	8-14
FIGURE 8-12: FIXED WING GPWS MODE 4.....	8-15
TABLE 8-10: GPWS MODE 5 ENVELOPES.....	8-15
FIGURE 8-13: FIXED WING GPWS MODE 5.....	8-16
TABLE 8-11: TAWS EXTERNAL SENSORS AND SWITCHES	8-17
TABLE 8-12: AIRPLANE TAWS BASIC PARAMETERS DETERMINATION.....	8-17
TABLE 8-13: TAWS AUTOMATIC INHIBIT FUNCTIONS	8-21
FIGURE 8-14: PFD SVS TAWS OPTION AND OBSTRUCTIONS	8-24
FIGURE 8-15: PFD SVS BASIC OPTION	8-25
FIGURE 8-16: PFD SVS TAWS OPTION.....	8-26
FIGURE 8-17: PFD OBSTRUCTION CAUTION.....	8-27
FIGURE 8-18: PFD OBSTRUCTION WARNING.....	8-28
FIGURE 9-1: US/UK WORLD MAGNETIC MODEL	9-3
TABLE 9-1: ALLOWABLE INSTRUMENT ERROR.....	9-4
TABLE 9-2: REGULATORY REFERENCE	9-4
TABLE 9-3: AIRSPEED ERROR.....	9-5
TABLE 9-4: AIRSPEED REGULATORY REFERENCE	9-6
TABLE 9-5: LOG FILE VALUES	9-8
FIGURE 9-2: VFR WAYPOINT.....	9-8
TABLE 9-6: SUMMARY OF ASTERISK SYMBOLOGY USE.....	9-9
FIGURE 9-3: NAV SOURCE MANAGEMENT	9-13
TABLE 9-7: NAV SOURCE INDICATIONS.....	9-13
FIGURE T-1: TRAFFIC PAGE ACCESS	T-1
FIGURE T-2: PFD MENU DCLTR AND FORMAT TRAFFIC.....	T-1
FIGURE T-3: MFD MENU FORMAT DCLTR TRAFFIC	T-2
FIGURE T-4: TRAFFIC SYMBOLOGY	T-3
TABLE T-1: TRAFFIC SYMBOLOGY.....	T-3
TABLE T-2: ADS-B AND TIS-B TRAFFIC SYMBOLS	T-4
FIGURE T-5: TCAS-II RA INDICATION	T-4

TABLE T-3: TRAFFIC RENDERING RULES	T-5
TABLE T-4: PILOT-SELECTED OT AND PA TRAFFIC ALTITUDE FILTERING	T-5
FIGURE T-6: TRAFFIC THUMBNAIL	T-6
FIGURE T-7: TRAFFIC DISPLAY FORMAT	T-6
FIGURE T-8: TRAFFIC PAGE COMPASS ROSE SYMBOLS	T-7
FIGURE T-9: CLOCK AND OPTIONS	T-7
TABLE T-5: CLOCK AND OPTIONS.....	T-7
FIGURE T-10: FUEL TOTALIZER/WAYPOINT DISTANCE FUNCTIONS	T-8
FIGURE T-11: MFD TRAFFIC FORMAT MENU	T-9
FIGURE T-12: MFD TRAFFIC IDENT (FORMAT) MENU	T-10
TABLE T-6: MENU SYNCHRONIZATION	T-10
FIGURE RBP-1: REMOTE BUGS PANEL	RBP-1
TABLE RBP-1: REMOTE BUGS PANEL (RBP)	RBP-2
TABLE S-1: LIGHTNING STRIKES	S-1
FIGURE S-1: LIGHTNING SYMBOLS	S-1
FIGURE S-2: AIR DATA AND GROUND SPEED IN UPPER LEFT CORNER	S-2
FIGURE S-3: CLOCK AND OPTIONS.....	S-3
TABLE S-2: WX-500 STATUS.....	S-3
FIGURE S-4: ACTIVE FLIGHT PLAN PATH/MANUAL COURSE/RUNWAYS	S-4
FIGURE S-5: FUEL TOTALIZER/WAYPOINT DISTANCE FUNCTIONS	S-4
FIGURE S-6: MFD STRIKES FORMAT (FORMAT) MENU	S-5
TABLE S-3: MENU SYNCHRONIZATION	S-5
FIGURE D-1: DATALINK SYMBOLOGY WITH G METAR ON.....	D-1
FIGURE D-2: DATALINK SYMBOLOGY WITH NEXRAD ON	D-1
TABLE D-1: ADS-B DATA	D-2
TABLE D-2: DATALINK NEXRAD DATA.....	D-2
TABLE D-3: GRAPHICAL METAR SYMBOLS	D-2
TABLE D-4: GRAPHICAL METARS (GMETARS) SCREEN RANGE	D-3
FIGURE D-3: NRST AIRPORT INFO	D-3
TABLE D-5: DATALINK GRAPHICAL METAR PRECIPITATION	D-3
FIGURE D-4: METAR AND TAF REPORT FOR KPHX	D-3
FIGURE D-5: DATALINK SYMBOLOGY OWNERSHIP SYMBOL	D-4
FIGURE D-6: ADS-B DATALINK LEGEND.....	D-4
FIGURE D-7: CLOCK/OPTIONS	D-4
TABLE D-6: DATALINK NEXRAD STATUS.....	D-5
FIGURE D-8: DATALINK PAGE SCREEN RANGE	D-6
TABLE D-7: DATALINK PAGE SCREEN RANGES	D-7
FIGURE D-9: BOUNDARY CIRCLE SYMBOL	D-7
FIGURE D-10: MFD DATALINK FORMAT MENU.....	D-9
TABLE D-8: TOP-LEVEL AUTO POP-UP FUNCTION DESCRIPTIONS	D-10
FIGURE D-11: FAULTS MENU WITH ADS-B STATUS.....	D-12
TABLE D-9: MENU SYNCHRONIZATION.....	D-12
TABLE WX-1: WEATHER RADAR INHIBITED CONDITIONS	WX-2
FIGURE WX-1: WEATHER RADAR IMAGE ON MAP	WX-2
FIGURE WX-2: PFD WEATHER RADAR IMAGE ON BOTTOM	WX-2
FIGURE WX-3: PFD WX RDR FORMAT MENU	WX-4

FIGURE WX-4: WX RDR DECLUTTER (DCLTR) MENU	WX-5
FIGURE WX-5: RADAR IMAGE IN ARC FORMAT	WX-6
FIGURE WX-6: RADAR IMAGE IN ARC FORMAT (STAB LIMIT).....	WX-6
FIGURE WX-7: RADAR IMAGE IN PROFILE DEPICTION	WX-7
FIGURE WX-8: RADAR IMAGE IN PROFILE DEPICTION (STAB LIMIT).....	WX-7
FIGURE WX-9: RADAR TRACK LINE.....	WX-8
FIGURE WX-10: RADAR TRACK LINE WITH MENUS	WX-9
FIGURE WX-11: RADAR ACTIVE FLIGHT PLAN	WX-9
FIGURE WX-12: RADAR ACTIVE FLIGHT PLAN WITH MENUS	WX-9
FIGURE WX-13: RADAR RETURN DATA.....	WX-10
TABLE WX-2: WEATHER RADAR RETURN DATA.....	WX-10
FIGURE WX-14: RADAR CLOCK/OPTIONS	WX-11
TABLE WX-3: RDR 2100 APPLICABILITY.....	WX-11
TABLE WX-4: RDR 2100 MODE ANNUNCIATION.....	WX-12
TABLE WX-5: MENU SYNCHRONIZATION	WX-34
FIGURE V-1: FIRST PAGE PFD VIDEO CONTROL	V-1
TABLE V-1: VIDEO INPUT CONTROLS	V-2
FIGURE V-2: ENCODER FUNCTIONS FOR MFD VIDEO PAGE	V-2
FIGURE V-3: MFD VIDEO INPUT FORMAT MENU	V-3
FIGURE V-4: VIDEO PAN VIEW	V-4
TABLE V-2: TOP-LEVEL AUTO POP-UP FUNCTION DESCRIPTIONS WITH PAN MODE ENABLED.....	V-4
FIGURE V-5: VIDEO STATUS	V-5
TABLE V-3: MENU SYNCHRONIZATION.....	V-5
FIGURE RD-1: PITCH SCALE.....	RD-1
FIGURE RD-2: FLIGHT DIRECTOR	RD-2
FIGURE RD-3: MARKER BEACON INDICATORS	RD-2
FIGURE RD-4: UNUSUAL ATTITUDE MODE.....	RD-3
FIGURE RD-5: BANK ANGLE SCALE TYPES	RD-3
FIGURE RD-6: PITCH LIMIT INDICATOR.....	RD-4
FIGURE RD-7: AGL INDICATOR	RD-4
TABLE RD-1: AGL ALTITUDE VALUES	RD-5
FIGURE RD-8: LANDING GEAR INDICATION.....	RD-5
FIGURE RD-9: AIRSPEED DISPLAY.....	RD-6
FIGURE RD-10: AIRSPEED DISPLAY LIMITS AND BUGS.....	RD-6
TABLE RD-2: AIRSPEED BUGS.....	RD-6
FIGURE RD-11: AIRSPEED READOUT WITH MACH NUMBER	RD-7
FIGURE RD-12: TAKEOFF AND LANDING SPEED BUGS	RD-9
FIGURE RD-13: ALTIMETER SETTING	RD-9
FIGURE RD-14: ALTIMETER QNH.....	RD-9
FIGURE RD-15: ALTIMETER QFE	RD-10
FIGURE RD-16: ALTITUDE DISPLAY	RD-10
FIGURE RD-17: ALTITUDE DISPLAY (WHEN BELOW SEA LEVEL).....	RD-10
FIGURE RD-18: AIRSPEED AND ALTITUDE WITH LOSS OF ADC.....	RD-11
FIGURE RD-19: TARGET ALTITUDE BUG	RD-11
FIGURE RD-20: VNAV SUB-MODE.....	RD-12

FIGURE RD-21: METRIC ALTITUDE	RD-12
FIGURE RD-22: VERTICAL SPEED INDICATOR	RD-13
FIGURE RD-23: VERTICAL SPEED INDICATOR RA DISPLAY	RD-13
TABLE RD-3: SCALE GRADUATIONS AND DISPLAY	RD-13
FIGURE RD-24: VSI BUGS	RD-14
FIGURE RD-25: HEADING DISPLAY	RD-14
FIGURE RD-26: HEADING INDICATOR WHEN AHRS IN DG MODE.....	RD-14
FIGURE RD-27: GPS TRK	RD-15
FIGURE RD-28: HEADING INDICATOR WITH HEADING FAILURE AND GOOD GPS	RD-15
FIGURE RD-29: HEADING INDICATOR WITH HEADING FAILURE WITH GPS FAILURE.....	RD-15
FIGURE RD-30: G-FORCE INDICATOR	RD-15
FIGURE RD-31: G-FORCE TELLTALE INDICATION	RD-16
FIGURE RD-32: TURN RATE INDICATOR	RD-16
FIGURE RD-33: TIMER INDICATION.....	RD-17
FIGURE RD-34: VERTICAL DEVIATION INDICATOR (VDI)	RD-17
TABLE RD-4: VERTICAL DEVIATION INDICATOR BEHAVIOR.....	RD-18
FIGURE RD-35: VDI COLOR DURING GPS/SBAS LON OR VLON.....	RD-19
FIGURE RD-36: COURSE DEVIATION INDICATOR.....	RD-19
TABLE RD-5: CDI BEHAVIOR AND COLOR	RD-20
TABLE RD-6: CDI LATERAL MODE INDICATION	RD-21
FIGURE RD-37: EFIS COUPLED VERTICALLY WITH GLIDESLOPE MODE ..	RD-22
FIGURE RD-38: ACTIVE WAYPOINT	RD-22
FIGURE RD-39: LOSS OF INTEGRITY (LOI)	RD-23
FIGURE RD-40: LOSS OF VERTICAL NAVIGATION (VLON)	RD-24
FIGURE RD-41: PFD FAILURE MODE 0 GPS, ADC AND AHRS NORMAL.....	RD-25
FIGURE RD-42: PFD FAILURE MODE GPS/SBAS FAILED, ADC AND AHRS NORMAL	RD-26
FIGURE SAR-1: EXPANDING SQUARE PATTERN.....	SAR-4
FIGURE SAR-2: EXPANDING SQUARE PATTERN PARAMETERS	SAR-4
TABLE SAR-1: EXPANDING SQUARE PATTERN PARAMETERS	SAR-5
FIGURE SAR-3: EXPANDING SQUARE PATTERN-TURN AND LEG	SAR-5
FIGURE SAR-4: EXPANDING SQUARE PATTERN-INDIVIDUAL LEG SELECTED	SAR-5
FIGURE SAR-5: RISING LADDER PATTERN	SAR-6
FIGURE SAR-6: RISING LADDER PATTERN PARAMETERS	SAR-6
TABLE SAR-2: RISING LADDER PATTERN PARAMETERS.....	SAR-6
FIGURE SAR-7: RISING LADDER PATTERN-TURN, LEG, AND TRACK.....	SAR-6
FIGURE SAR-8: RISING LADDER PATTERN-INDIVIDUAL LEG SELECTED ..	SAR-7
FIGURE SAR-9: ORBIT PATTERN	SAR-7
FIGURE SAR-10: ORBIT PATTERN PARAMETERS	SAR-7
TABLE SAR-3: ORBIT PATTERN PARAMETERS.....	SAR-7
FIGURE SAR-11: ORBIT PATTERN-TURN AND RADIUS	SAR-8
FIGURE SAR-12: RACE TRACK PATTERN	SAR-8

FIGURE SAR-13: RACE TRACK PATTERN PARAMETERS.....	SAR-8
TABLE SAR-4: RACE TACK PATTERN PARAMETERS	SAR-9
FIGURE SAR-14: RACE TRACK PATTERN-TURN, LEG, AND TRACK	SAR-9
FIGURE SAR-15: SECTOR SEARCH PATTERN.....	SAR-9
FIGURE SAR-16: SECTOR SEARCH PATTERN PARAMETERS	SAR-10
TABLE SAR-5: SECTOR SEARCH PATTERN PARAMETERS	SAR-10
FIGURE SAR-17: SECTOR PATTERN-TURN AND TRACK	SAR-10
FIGURE SAR-18: SECTOR SEARCH PATTERN-INDIVIDUAL LEG SELECTED	SAR-10
.....	SAR-10

Section 1 Introduction

1.1. Introduction

The Genesys Aerosystems Electronic Flight Instrument System (EFIS) is a “pilot-centered” system. While still highly automated, it presents the pilot with information necessary to make decisions and take appropriate actions. For example, the Highway-in-the-Sky (HITS) allows for highly automated approaches, but its predictive nature provides the pilot awareness of upcoming maneuvers. Instead of overloading the pilot with information and options, the Genesys Aerosystems EFIS presents only necessary information to reduce workload, decrease task complexity, and minimize confusion, which results in safer flying with less stress and fatigue.

1.2. EFIS/FMS Description



Figure 1-1: IDU-680 Input Identification

The integrated display unit (IDU) has 16 buttons along the vertical sides referenced as L1 through L8 starting at the top left corner of the display moving down and R1 through R8 from the top right corner moving down the display from a pilot's perspective.

Four encoders at the bottom of the bezel are designated, from left to right, ④, ③, ②, and ①. References throughout this guide refer to which encoder to push and/or rotate for desired outcomes, but ④ only controls the backlighting intensity.

A sensor on the face of the IDU bezel measures ambient light levels. Use ④ to control the brightness of the panel or display lighting. To adjust panel lighting (illumination of legends, encoders, inclinometer, and buttons), push and rotate ④ clockwise to increase or counter clockwise to decrease. To adjust display lighting (illumination of the LCD display), without pushing rotate ④ as described with panel lighting. Lighting may be controlled locally or remotely with a default state being with the local control.

NOTE:

If entering ground maintenance mode with bright light shining or reflecting directly into the display, shield the light sensor to avoid the IDU from going directly into the flight mode.

On the bezel between the two center encoders, a slip indicator or blank housing acts as the USB memory door. Lift it prior to power-up to initiate the ground maintenance mode after power-up. If a limits change, software, or database update is planned, the USB drive must be inserted prior to power-up.

1.3. About This Guide

Operation of the Genesys Aerosystems EFIS is described in detail and divided into sections as follows:

TABLE OF CONTENTS: Locate areas by topic

INTRODUCTION (Section 1): Basic explanation of the pilot guide.

SYSTEM OVERVIEW (Section 2): Description of system and hardware; IDU behavior during initialization, warning alerts, time-critical warning alerts, master visual and aural alerts caution alerts, and advisory alerts with conditions; coloring conventions; abbreviations and acronyms; and database update procedures.

DISPLAY SYMBOLOGY (Section 3): Identification of each screen element of the primary flight display (PFD) and multi-function display (MFD), and explanation of symbology.

REVERSIONARY MODES (Section 4): Views of displays with various sensor failed conditions and resulting symbology, as well as, examples of various configurations and display formats used with specific tables showing affected functions. Explanation of what to expect when a particular sensor fails and what changes on the display immediately or after a specified amount of time.

MENU FUNCTIONS AND STEP-BY-STEP PROCEDURES (Section 5): Menu structure of each feature and step-by-step procedures for each task. Basic description of all encoder and button functions with menu tile definitions.

QUICK START TUTORIAL (Section 6): Basics necessary for flying a flight with this system. Includes simple steps to manage displays for existing flight conditions to quickly gain familiarity with where to locate controls to manipulate the system for each operation.

IFR PROCEDURES (Section 7): Detailed information and instruction about selecting and flying instrument procedures with examples of the most popular published procedures with views of referenced published procedures. Includes descriptions of selection of departure, published instrument approach, standard terminal arrival procedures, as well as, how the active flight plan quickly reflects changes to ATC clearances.

TERRAIN AWARENESS WARNING SYSTEM (Section 8): Description of the TAWS (all classes) functionality for this fixed wing aircraft with all configurations. Defines the various parameters, which automatically apply to each mode of flight.

APPENDIX (Section 9): Contains support material and other useful information about system operation, guidance from Jeppesen, and supplemental information such as flight planning; magnetic vs. true north modes; airspeed/altitude miscompare thresholds; EFIS Training Tool; and downloading routes and user waypoints.

APPENDICES: Traffic, Remote Bugs Panel, WX-500 Lightning Strikes, Datalink, Video, Weather Radar, Round Dials, and Search and Rescue Patterns. Sections on equipment and features not installed in every aircraft may be removed at the discretion of the end-user.

INDEX: Alphabetical listing of terms or keywords with corresponding page numbers.

GLOSSARY: Alphabetical listing of definitions for terms.

Section 2 System Overview

2.1. Abbreviations and Acronyms

OR	No Radius
3D	Three-Dimensional
AC	Advisory Circular
ACTV	Active
ADAHRS	Air Data Attitude Heading Reference System
ADC	Air Data Computer
ADF	Automatic Direction Finder
ADS-B	Automatic Dependent Surveillance-Broadcast
AFCS	Automatic Flight Control System
AFM	Aircraft Flight Manual
AFMS	Aircraft Flight Manual Supplement
AGL	Above Ground Level
AHRS	Attitude Heading Reference System
AIRAC	Aeronautical Information Regulation and Control
AIRMET	Airmen's Meteorological Information
ALT	Pressure Altitude
ALT SEL	Altitude Selection
AMLCD	Active Matrix Liquid Crystal Display
ANP	Actual Navigation Performance
ANT	Antenna
AOA	Angle of Attack
APP	Waypoint is part of an Instrument Approach Procedure
APPR	Approach
APT	Airport
APV	Approach with Vertical Guidance
ARINC	Aeronautical Radio, Inc.
ARL	Auto Range Limiting (RDR-2100)
ARTCC	Air Route Traffic Control Center
AS	SAE Aerospace Standard
ASEL	Aircraft Selected Altitude
ATC	Air Traffic Control

ATT	Attitude
Baro	Barometric setting
Baro-VNAV	Barometric Vertical Navigation
BC	Backcourse navigation
BIT	Built-in-test
BRT	Brightness
BTM	Bottom
C	Celsius
CA	Course to Altitude (ARINC-424 Leg)
CALC	as in RAIM (R2)
CAS	Crew Alerting System
CD	Course to DME Distance (ARINC-424 Leg)
CCW	Counter Clockwise
CDA	Continuous Descent Approach
CDI	Course Deviation Indicator
CF	Course to Fix (ARINC-424 Leg)
CI	Course to Intercept (ARINC-424 Leg)
CLR	Clear
CNX	Cancel
COM	Communication
CONT	Continue
CPLT	Co-Pilot
CPM	Computer Processor Module
CPU	Central Processing Unit
CR	Course to Radial Termination (ARINC-424 Leg)
CRC	Cyclic Redundancy Check
CRS	Course
CSA	Conflict Situation Awareness (ADS-B)
CTRST	Contrast
CW	Clockwise
dBZ	Decibel relative to radar reflectivity (Z)
DCLTR	Declutter
DCND	Descend
DEC HT	Decision Height Bug

DEL	Delete
DESIG	Designate
DF	Direct to Fix (ARINC-424 Leg)
DFCS	Digital Flight Control System
DFLT	Default
DG	Directional Gyro
DH	Decision Height
DLNK	Datalink
DME	Distance Measuring Equipment
DO	RTCA Document
DOD	Department of Defense
DP	Departure Procedure
DR	Dead Reckoning
ECBU	Electronic Circuit Breaker Unit
EFIS	Electronic Flight Instrument System
EGM	Earth Gravity Model
EGNOS	European Geostationary Navigation Overlay Service
EGPWS	Enhanced Ground Proximity Warning System
EQPMNT	Equipment
ESSNTL	Essential
ETA	Estimated Time of Arrival
ETE	Estimated Time Enroute
ETT	EFIS Training Tool
EXCD	Exceedance
EXPND	Expand (also EXP)
F	Fahrenheit
FA	Course from a Fix to Altitude (ARINC-424 Leg)
FAA	Federal Aviation Administration
FAF	Final Approach Fix
FAR	Federal Aviation Regulation
FAWP	Final Approach Waypoint (same as FAF)
FC	Course Fix to along Track Distance (ARINC-424 Leg)
FD	Course from a Fix to DME Distance (ARINC-424 Leg); Flight Director

FDE	Fault Detection and Exclusion
FG	Fixed Gear
FG + F	Fixed Gear with Defined Landing Flaps Position
FIS	Flight Information Service
FIS-B	Flight Information Service-Broadcast
FL	Flight Level
FLTA	Forward Looking Terrain Awareness
FM	Course from Fix to Manual termination (ARINC-424 Leg)
FMS	Flight Management System
FOV	Field of View
FPAP	Flight Path Alignment Point
FPL	Flight Plan
fpm	Feet per minute
FPM	Flight Path Marker
FPNM	Feet Per Nautical Mile
FRT	Fixed-Radius Transition
FSD	Full Scale Deflection
FT	Feet
FTE	Flight Technical Error
FTP	Fictitious Threshold Point
FNCT	Function
GAGAN	India's GPS and GEO-Augmented Navigation System
GARP	GNSS Azimuth Reference Point
GBAS	Australia's Ground Based Augmentation System
GLS	GNSS Landing System
GMETAR	Graphical METAR (also GMTR)
GMF	Ground Maintenance Function
GN	Gain
GND	Ground
GNSS	Global Navigation Satellite System
GPI	Glidepath Intercept
GPIP	Glide Path Intercept Point
GPS	Global Positioning System
GPSV	Global Positioning System Vertical Navigation

GPWS	Ground Proximity Warning System
GS	Glideslope
H	Hold
HA	Terminates at an altitude (ARINC-424 Leg)
HF	Holding, Pattern to Fix (ARINC-424 Leg)
HM	Altitude or Manual Termination (ARINC-424 Leg)
HAL	Horizontal Alert Limit
HAT	Height Above Threshold
HDG	Heading
HFOM	Horizontal Figure of Merit
hh:mm:ss	Hours: Minutes: Seconds
HITS	Highway in the Sky
HLTH	Health
HORIZ	Horizontal
HOTAS	Hands on Throttle and Stick
hPa	Hectopascal
HPL	Horizontal Protection Level
HSI	Horizontal Situation Indicator
HUD	Head Up Display
IAP	Instrument Approach Procedure; Initial Approach Point
IAS	Indicated Airspeed
IAWP	Initial Approach Waypoint (same as IAP)
ICAO	International Civil Aviation Organization
ID	Identity or Identification
IDU	Integrated Display Unit
IF	Initial Fix leg
IFR	Instrument Flight Rules
ILS	Instrument Landing System
IM	Inner Marker
INFO	Information
INHBT	Inhibit
inHg	Inches of Mercury
INIT	Initialize
IO	Input/Output

IP	Initial Point
IPV	Instrument Procedure with Vertical Guidance
ISA	International Standard Atmosphere
IVSI	Instantaneous Vertical Speed Indicator
IWP	Intermediate Approach Waypoint
K	Kilo=1000
KB	Kilobyte
kHz	Kilohertz
KIAS	Knots Indicated Airspeed
KT	Knot - Nautical Miles per Hour
KTAS	Knots True Airspeed
LAT	Latitude
lbs	Pounds
LCD	Liquid Crystal Display
LCL	Local
LDA	Localizer-type Directional Aid
LED	Light Emitting Diode
LGND	Legend
LIFR	Low IFR conditions (Ceiling < 100' or visibility < 1 mile)
LNAV	Lateral Navigation
LOC	Localizer
LOI	Loss of Integrity
LON	Loss of Navigation; Longitude
LP	Localizer Performance
LPV	Localizer Performance with Vertical Guidance
LTP	Landing Threshold Point
LVL	Level
MA	Waypoint is part of the missed approach segment of an Instrument Approach Procedure
MAGVAR	Magnetic Declination (Variation)
MAHP	Missed Approach Holding Point
MAHWP	Missed Approach Holding Waypoint (same as MAHP)
MAN	Manual
MAP	Missed Approach Point; Missed Approach Procedure

MASPS	Minimum Aviation System Performance Standard
MAWP	Missed Approach Waypoint (also MAWPT)
mbar	Millibars
MDA	Minimum Descent Altitude
MESO	Mesocyclonic
METAR	Routine hourly weather report
MFD	Multifunction Display
MIN	Minimum
MM	Middle Marker
M _{MO}	Maximum Operating Mach Number
M _{NO}	Maximum Structural Cruising Mach Number
MOA	Military Operations Area
MOT	Mark On Target
MSAS	Japan's MTSAT-based Satellite Augmentation System
MSG	Message
MSL	Mean Sea Level
MVFR	Marginal Visual Flight Rules
NAS	U.S. National Airspace System
NAV	Navigation
NAVAID	Device or system providing navigational assistance
ND	Navigation Display
NDB	Nondirectional Beacon
NEXRAD	(Next-Generation Radar) network of weather radars operated by the National Weather Service (NWS) (also NXRD)
NIMA	National Imagery and Mapping Agency
NM	Nautical Mile
NRST	Nearest
nT	Nanoteslas (ref. World magnetic Model)
NWS	National Weather Service
OAT	Outside Air Temperature
OBS	Omnibearing Selector
ODP	Obstacle Departure Procedure
OF	Over-fly
OM	Outer Marker

OT	Other Traffic (Traffic Function)
PA	Proximate Advisory (Traffic Function)
PDA	Premature Descent Alert
PFD	Primary Flight Display (also refers to the primary IDU with software that only shows primary flight instrumentation)
PFI	Primary Flight Information
PI	Procedure Turn (ARINC-424 Leg)
PLI	Pitch Limit Indicator
PLT	Pilot
PM	Personality Module
PN	Pan
PROC	Procedure
PRN	Pseudo-Random-Noise (Satellite communications)
PRS	Press
PRV	Previous
PSH	Push
PTK	Parallel offset (Parallel Track)
PTRS	Pointers
PWR	Power
QFE	Altimeter setting provides height above reference point
QNE	Altimeter setting provides pressure altitude readout
QNH	Altimeter setting provides MSL altitude at a reporting point
RA	Resolution Advisory (Traffic Function)
RADALT	Radar Altimeter (also RALT)
RAD-DST	Radial and Distance
RAIM	Receiver Autonomous Integrity Monitoring
RBP	Remote Bug Panel
RF	Precision Arc to Fix (ARINC-424 Leg)
RG	Retractable Gear
RG + F	Retractable Gear with Defined Landing Flaps Position
RHT	Radar Height
RMI	Radio Magnetic Indicator
RNAV	Area Navigation
RNP	Required Navigation Performance

RTC	Real Time Computing
RTCA	Radio Technical Commission for Aeronautics
RTD	Resistive Thermal Detector
RW	Runway
SAE	Society of Automotive Engineers
SAR	Search and Rescue
SAT	Saturation
SATLT	Satellite
SBAS	Satellite-Based Augmentation System
SCC	System Configuration Card (personality module)
SECAM	Analog color television system used in France
SIC	Side-in-Command
SID	Standard Instrument Departure
SIGMET	Significant Meteorological Advisory
SSM	Sign Status Matrix
STAB	Stability
STAR	Standard Terminal Arrival Routes
STBY	Stand-by
STD	Standard
STRKS	Strikes (Lightning detection)
SVS	Synthetic Vision System
SYMB	Symbol
SYNC	Synchronize
SYRD	System Requirements Document
TA	Traffic Advisory (Traffic Function)
TACAN	Ultra-High Frequency Tactical Air Navigational Aid
TAFs	Terminal Aerodrome Forecasts
TAS	Traffic Advisory System; True Airspeed
TAWS	Terrain Awareness and Warning System
TCA	Terminal Control Areas
TCAD	Traffic Collision Alert Device
TCAS	Traffic Collision Alert System
TD	Terrain Data
T/D	Top of Descent

TERPS	Terminal Instrument Procedures
TF	Track to a Fix; Track from Fix to New Fix (ARINC-424 Leg)
TFR	Temporary Flight Restriction
TGT	Target
TIS	Traffic Information Service
TIS-B	Traffic information Service-Broadcast
TLT	Tilt
TRANS	Transition
TRK	Track
TRNDO	Tornadic
TSO	Technical Standard Order
TTA	Time to Alert
TURB	Turbulence
USB	Universal Serial Bus flash drive
USR	User Waypoint
UTC	Universal Time Coordinated
VA	Heading to Altitude (ARINC-424 Leg)
V _A	Speed above which it is unwise to make full application of any single flight control
VAL	Vertical Alert Limit
V _{APP}	Target approach airspeed
VD	Heading to DME Distance (ARINC-424 Leg)
VDI	Vertical Deviation Indicator
VERT	Vertical
V _{FE}	Maximum flap extended speed
VFOM	Vertical Figure of Merit
VFR	Visual Flight Rules
VHF	Very High Frequency
VI	Heading to Intercept (ARINC-424 Leg)
VLOC	VOR/Localizer
VLON	Vertical Loss of Navigation
VM	Heading to Manual Termination (ARINC-424 Leg)
V _{MO}	Maximum operating limit speed
VNAV	Vertical Navigation (also VNV)

V _{NE}	Never exceed speed
V _{NO}	Maximum structural cruising speed or maximum speed for normal operations
VOR	VHF Omnidirectional Radio
VORTAC	Collocated VOR and TACAN
VP	VFR waypoints (five digits beginning with “VP”)
VPL	Vertical Protection Level
V _{PROC}	Procedure Speed
V _R	Rotation speed
VR	Heading to Radial Termination (ARINC-424 Leg)
V _{REF}	Landing reference speed or threshold crossing speed
VS	Vertical Speed
VSI	Vertical Speed Indicator
VTF	Vectors to Final
V _{YSE}	Best rate of climb speed with a single operating engine a light twin-engine aircraft
WAAS	Wide Area Augmentation System
WGS84	World Geodetic System 1984
WOG	Weight on Ground
WOW	Weight on Wheels
WPT	Waypoint
WX	Weather
WXA	Weather-alert (RDR-2100)
XFILL	Crossfill

2.2. System Overview

The IDU-680 EFIS is a complete flight and navigation instrumentation system providing information via computer-generated displays. The displays include 3D, enhanced situational awareness primary flight display (PFD) and multi-function display (MFD), which may be configured to show a moving map, Nav Log, HSI, terrain, traffic, Weather Radar, Video, or datalink page.

At any given time, each EFIS side, only has one IDU transmit enabled to send RS-232 and RS-422 system transmissions. By default, the PFD is transmit enabled and, if it subsequently fails, the respective MFD becomes transmit enabled.

Table 2-1 describes the EFIS limits set for all screen captured views for this pilot guide development except where different settings are noted.

Table 2-1: Pertinent EFIS Limits Settings	
Category	Setting
Screen Position Settings:	
Screen Number	#1 or #2 as specified
Aircraft Type	Generic
Speed Settings:	
Airspeed Scale Type	FAR 23.1545 with and without V_{MO}/M_{MO}
Airspeed Units	Knots
Pilot-side analog configuration	Tapes
Digital configuration	Pure Digital (or Rolling where depicted)
Optional Sensor Settings:	
Datalink Receiver	ADS-B
TAWS Type	Class A (RG + Flaps)
Traffic Sensor	TCAD/TAS (RS-232)
WX-500 (STRIKES)	Installed
SAR Patterns	Enabled
Airframe Settings:	
External Lights on Critical Alerts	Disabled
Always show CAS in ESSENTIAL Mode	Disabled
Landing Gear Configuration	Retractable
Temperature Units	°C
Mach Display enable	Enabled
Map Encoder Rotation	CW increase Range (MAPs/WX RDR)
Maximum AGL Display	2500'
Minimum Obstacle Height	0'
PLI Display	Enabled
Roll Indicator Type	Sky Pointer
Slip-Skid Display	Enabled
Minimum Runway length	3000'
Positive G-Limit	3.5
Negative G-Limit	-1.5
Show Full MFD Status	Enabled
Show MFD Density Alt	Enabled
Show MFD IS Tem Deviation	Enabled
Show MFD True Airspeed	Enabled
Autopilot Settings:	
Autopilot Type	Analog
Flight Director	Enabled
Flight Director on Side-in-Command	Disabled
Basic Sensor Settings:	

Table 2-1: Pertinent EFIS Limits Settings

Category	Setting
Remote Tuning	Cobham CD/Honeywell...
ADF System	Dual
ADC System	Dual
Baro Autosetting on Startup	Enabled
Synch pilot/Copilot Baro	Enabled
AHRS System	Dual
Analog interface unit	Installed
DME System	Dual RC DME4000
EFIS System	Dual (Pilot-Side defaults to #1 Sensors)
Cockpit Arrangement	Side-by-Side
Pilot Position	Left
GPS System	Dual
Radar Altimeter	Dual
Dual DH	Disabled
Baro Agl	Enabled
VOR System	Dual
VIDEO Input Settings:	
VIDEO-1 Force NTSC	Label= FLIR
VIDEO-2 Force NTSC	Label= TAC MAP
DVI Button Label	To DVI
Weather Radar Settings:	
WX RDR Enable Screen #1	Enabled
WX RDR Enable Screen#2	Enabled
WX RDR Enable Screen#3	Disabled
WX RDR Enable Screen #4	Disabled
WX RDR Type	Honeywell RDR-2100
External Radar Control Panel	Not Installed
Radar Scan Width	100° (± 50°)
Discrete Input Settings:	
GPI# 1	All Landing Gear Down
GPI# 2	TAWS Landing Flaps
GPI# 3	TAWS Glideslope Inhibit
GPI# 4	TAWS Inhibit
GPI# 5	No Function
AIU# 3	Weight On Ground/Wheels
Aircraft Fuel Settings:	
Fuel Totalizer	Enabled
Fuel Tank Count	2
Fuel Flow Count	2
Unmonitored Fuel	N/A
Volume Units	Lbs. (Jet Fuel)
Aircraft Total Fuel QTY	3750

Table 2-1: Pertinent EFIS Limits Settings

Category	Setting
Aircraft Main Fuel Quantity	3400
Totalizer Fuel Increments	25
Aircraft low Fuel Caution	750
Aircraft Low Fuel Alarm	400
Wing Tank Split Caution	Disabled
Totalizer Mismatch Caution	Disabled
Fuel Tank #1 Settings:	
Tank Type	Left Wing Tank
Fuel Tank QTY	1600 LBS
Fuel Tank Caution	375 LBS
Fuel Tank Alarm	200 LBS
Fuel Tank #2 Settings:	
Tank Type	Right Wing Tank
Fuel Tank QTY	1600 LBS
Fuel Tank Caution	375 LBS
Fuel Tank Alarm	200 LBS

The engine instruments and crew alerting system (EICAS) is an OASIS page that includes displays for engine parameters and other aircraft information for the crew to manage the aircraft systems.

NOTE:

See the Aircraft Flight Manual Supplement (AFMS) for OASIS information, if applicable.

Radio tuning, settings control, and audio control are managed within the IDU on the Audio/Radio Management (ARM) page (see AFMS as applicable).

In an IFR installation, the primary IDU-680 is configured so only the primary flight information (PFI) in top area and multi-function display (MFD) page in bottom area are displayed.

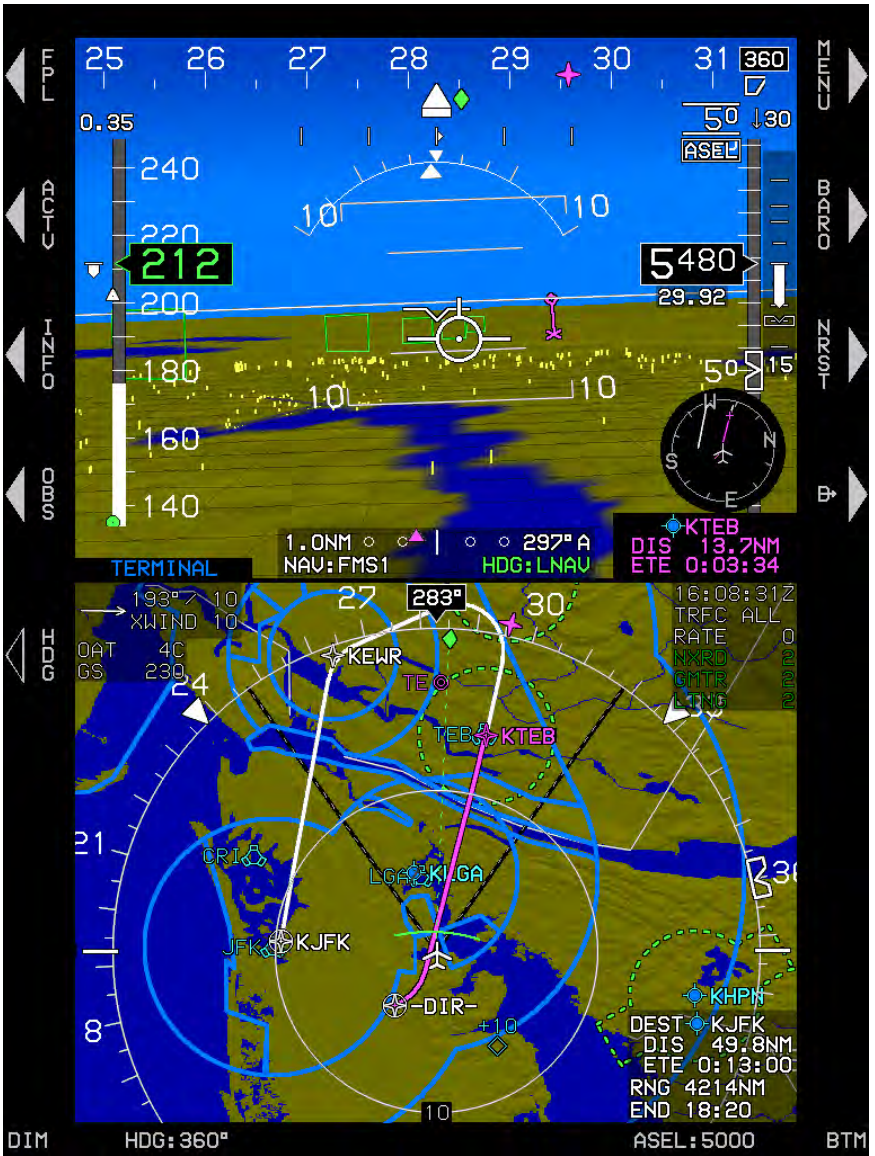

Figure 2-1: IDU-680 Primary Flight Display (PFD) with PFI and Navigational Display (ND) Map Page

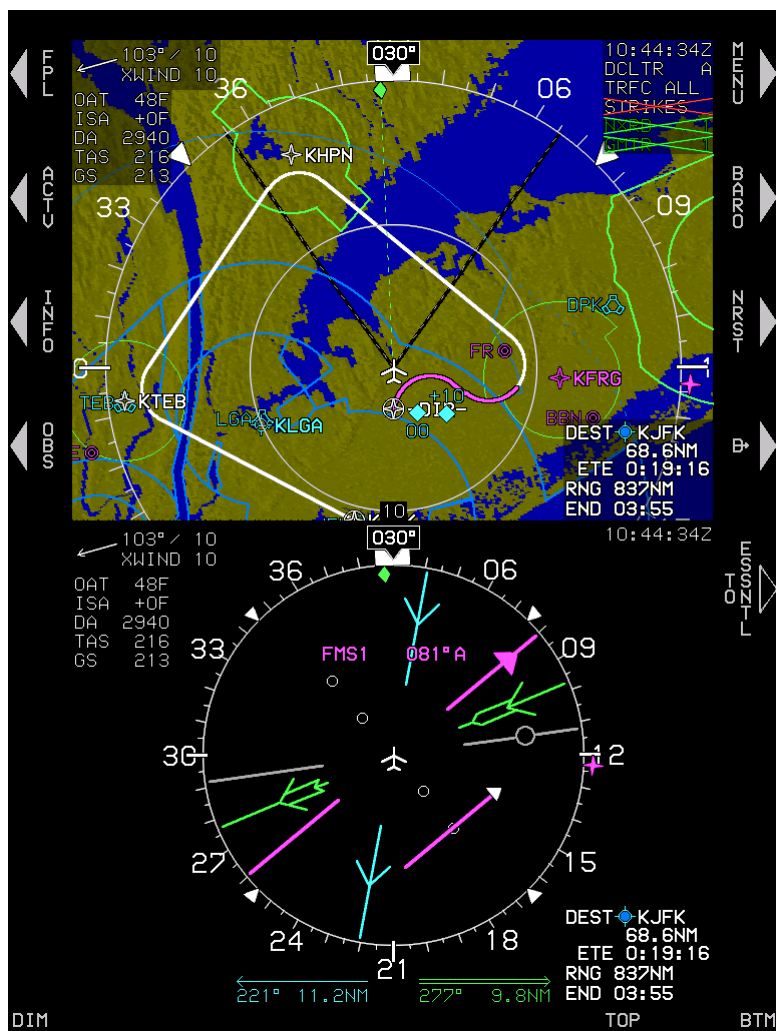

Figure 2-2: IDU-680 Multifunction Display (MFD)

2.2.1. Functional Integration and Display Redundancy

IDUs incorporate a high-brightness AMLCD screen; bezel buttons; encoders and enter switches; central processing unit; numerous RS-232, RS-422, and ARINC 429 receive and transmit ports; and discrete IO ports. Hardware and software are identical for all IDUs, and functionality is determined by configuration settings setup during installation. The IDUs are independently connected to all external sensors and independently perform all integrated functions (e.g., TAWS, FMS, ADS-B In, strikes, traffic, etc.).

The IDUs depend upon intra-system (between IDUs on a side – depicted as “Sync” in Figure 2-3) and inter-system (between IDUs on opposite sides – depicted as “Crosslink” in Figure 2-3) to achieve synchronization of integrated functions. They also depend upon intra-system communications to determine which IDU on a side (pilot or co-pilot) takes over “talker” responsibilities. The “talker” IDU is the IDU providing data to external sensors and generating audible alerts.

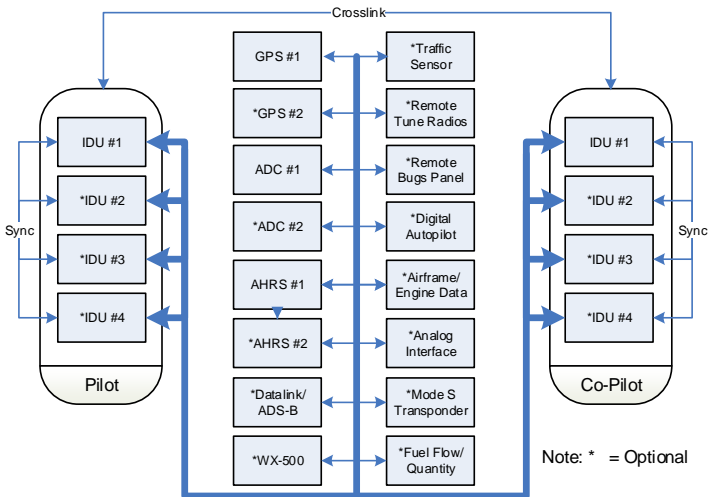

Figure 2-3: System Diagram

2.2.2. IDU Initialization



Figure 2-4: IDU-680 Initialization Screen

The hardware, including file system, IO, and graphics, is initialized. Immediately after graphics initialization, a screen with “INITIALIZING” is displayed with the Genesys Aerosystems logo, software version number,

and part number. The software version number delineates: (1) major revision number (i.e., “8.0”), and (2) minor revision letter (i.e., “K”).

Table 2-2: IDU Software Version and Part Number

Version Number	Part Number
Rev 8.0K	25-EFIS80K-SW-0003

Aircraft configurations are initially read from flash drive storage to provide IDUs with a default configuration setup in the event of personality module failure. The personality module contains the CPU (IDU) number (Table 2-3) and side designation (pilot or co-pilot). The IDU number is identified below the part number on the CRC screen (Figure 2-6).

Table 2-3: IDU Number Designation

CPU/IDU #	Definition
“0”	Single-screen installation
“1”	IDU only shows PFD
“2”	First MFD in multi-screen installation
“3”	Second MFD in a multi-screen installation
“4”	Third MFD in a multi-screen installation

Pilot IDU #1 reads aircraft configuration from its personality module. In a multi-screen installation, IDU #1 transmits this configuration to the other IDUs. The other IDUs save the transmitted configurations to flash drive storage.

Aircraft parameters (latitude, longitude, altitude), as they existed prior to the last system shutdown, are read for a good system initialization, even if system sensors are failed or not yet initialized. For future updates (i.e., updating software version 8.0K to 9.0A), all aircraft settings re-initialize to default values. Otherwise, aircraft settings, as they existed prior to the last system shutdown, are used to initialize the system except for the following default values:

- 1) Selected sensors are initialized to default values.
- 2) Active flight plan structure and associated values are cleared.
- 3) ADAHRS set to slaved mode, and slewing value is initialized to zero.
- 4) Timers are turned off.
- 5) Datalink and map panning modes are set to off.
- 6) Fuel caution and alarm thresholds are set to default values.

- 7) Heading bug is set to 360° (analog autopilot [AP] or Genesys/S-TEC DFCS enabled) or turned off.
- 8) Heading mode is turned off.
- 9) HSI navigation source is set to FMS.
- 10) Minimum altitude setting is turned off.
- 11) FMS OBS setting is set to automatic.
- 12) VOR/LOC 1 OBS setting is set to 360°.
- 13) VOR/LOC 2 OBS setting is set to 360°.
- 14) Parallel offset is set to 0 NM.
- 15) PFD zoom mode is set to off.
- 16) Manual RNP is set to off.
- 17) If in round dial mode, analog AGL is set to off.
- 18) If in round dial mode, analog G indicator is set to off.
- 19) Analog G-Indicator is set to off.
- 20) PFD skyway is set to on.
- 21) Airspeed bug is turned off.
- 22) Target and preselected altitude bugs are turned off
- 23) True north mode is turned off.
- 24) V-speeds are cleared.
- 25) Vertical speed bug is turned off.
- 26) Crosslink is initialized to on.
- 27) If Genesys/S-TEC DFCS is enabled, flight directors are initialized to single-cue.
- 28) Map modes are set to allowed values.
- 29) G telltales are automatically reset so long as the associated G limit has not been exceeded.
- 30) Essential mode is set to off.

The magnetic variation coefficients database is read from the flash drive storage and CRC-32 checked.

The EFIS determines whether it is booting on the ground or in flight based on the air/ground mode parameter value from the last system shutdown. If booting on the ground, the following actions happen:

- 1) A logo screen with “**TESTING**” is displayed.



Figure 2-5: Logo Screen with “TESTING”

- 2) CRC-32 values for application executable, limitations files, NavData files, obstruction files, sounds database, and terrain header files are checked.

During this action, “**PRESS ANY BUTTON TO QUICK START**” is displayed below “**TESTING.**” Press any button to stop the ground booting and execute the flight booting.

- 3) If the BIT (built-in-test) check fails, the program exits with an error message and creates a BIT result file indicating failure.
- 4) If the BIT check passes, the program continues to initialize and creates a BIT result file indicating passage.
- 5) If “Baro Auto-Setting on Startup Flag” is enabled in EFIS limits, the system auto-sets the altimeter based on the terrain elevation at the startup point (only applicable at surveyed airports.) In QFE mode operation, the system auto-sets the altimeter to read zero altitude.
- 6) A logo screen displaying:
 - a) Software CRC-32;
 - b) Aircraft type;
 - c) OASIS configuration name and CRC-32, if configured;
 - d) Audio/Radio configuration name and CRC-32, if configured;

- e) Audio/Radio channel presets configuration name and CRC-32, if configured;
- f) Sounds database name and CRC-32;
- g) Magnetic variation coefficients version and CRC-32; and
- h) Database versions and validity dates are displayed along with **“PRESS ANY BUTTON TO CONTINUE.”**

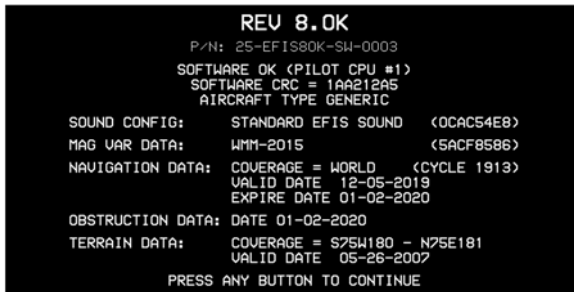

Figure 2-6: CRC Screen

- 7) If all critical sensors (GPS, ADC, and AHRS) are in normal condition, the display screens are shown immediately.
- 8) If any critical sensor is not in normal condition, a logo screen with a two-minute countdown timer is displayed along with **“PRESS ANY BUTTON TO SKIP.”**



Figure 2-7: Two-Minute Countdown Screen

- 9) The display screens initialize at the earliest of:
 - a) when 2 minutes has elapsed;
 - b) when the pilot presses any button to escape startup countdown; or
 - c) when all critical sensors are in normal condition.

- 10) The display screen is shown at the earliest of:
 - a) IDU #1: PFD Normal mode with PFD on top, an MFD page (last selected MFD page on this IDU) on bottom.
 - b) Other IDUs: Initialize to MFD on top and MFD on bottom.
- 11) On all IDUs with fuel totalizer functions enabled, the fuel set menu is activated to remind the pilot to set the fuel totalizer quantity.
- 12) All active alerts are automatically acknowledged for 5 seconds to reduce nuisance alerting.

If booting in the air, the following actions happen:

- 1) A logo screen with “**QUICK START**” is displayed.



Figure 2-8: QUICK START Screen

- 2) BIT result file created during the last ground boot is checked.
 - a) **Failure** = indicates a failure, program exits with an error message.
 - b) **Passage** = program continues.
- 3) The display screens initialize immediately as follows:
 - a) IDU #1: PFD normal mode (PFD on top, MFD on bottom).
 - b) Other IDUs: Initialize to MFD on top and MFD on bottom.

NOTE:

After IDU initialization, if any menu is active, press **EXIT (R1)** on each display and wait at least 20 seconds to allow PFDs to sync with MFDs and pilot and copilot sides to sync (as applicable). If any IDU menu is active, intra-system and inter-system synchronization messages are paused.

2.3. General Arrangement



Figure 2-9: PFD PFI on Top and Map on Bottom

The IDU-680 is 7.500"W x 10.250"H x 4.750"D and weighs less than 9.5 lbs. It has the capacity to accommodate integrated peripherals mechanically attached to the IDU but have electrical isolation and redundancy. These modules may include:

- 1) Integrated ADAHRS Sensor Module
- 2) Integrated GPS/SBAS Sensor Module
- 3) Serial Protocol Converters
- 4) Video Format Converters

Data storage is sufficiently sized to hold world terrain, navigation, and obstruction databases. Because the receive ports are connected to the digital sensor modules in parallel, each IDU is independent from all others.

2.3.1. Normal and Essential Modes

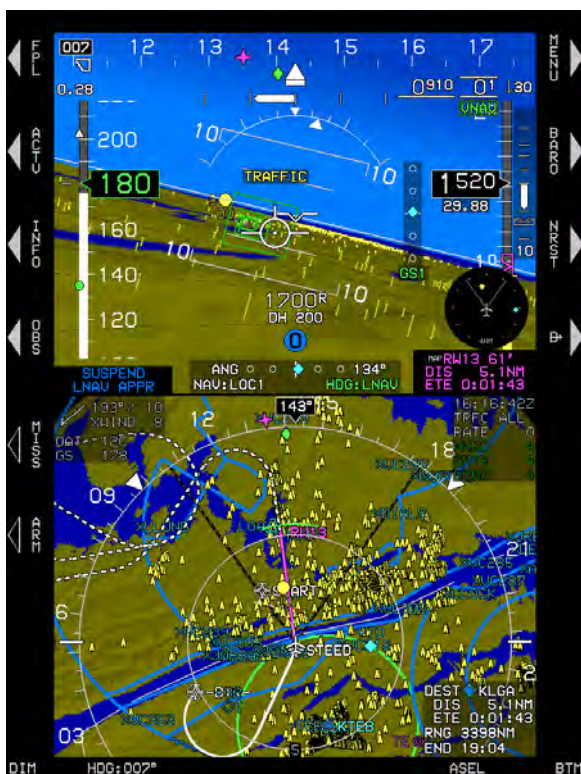

Figure 2-10: PFD Normal Mode

IDU software has normal mode and essential modes. The PFD has only a normal mode and the MFD has normal and essential modes. See Section 3 Display Symbology for additional information. IDUs configured as #1 have a PFI page in the top area and a pilot-selectable multi-function page in the bottom area. If OASIS is configured, PFD Essential mode has the PFI on top and OASIS EICAS on the bottom to provide everything needed for continued safe operation.

Press **(R5)** to toggle Normal and Essential modes. On PFD button is labeled **TO NORMAL** or **TO ESSNTL** (when configured with OASIS/EICAS). On MFD, button is labeled **TO ESSNTL** or **TO MFD**. Mode change is instantaneous.

If IDUs configured as #2, #3 or #4 are installed, their normal mode is pilot-selectable multi-function pages in both top and bottom areas.

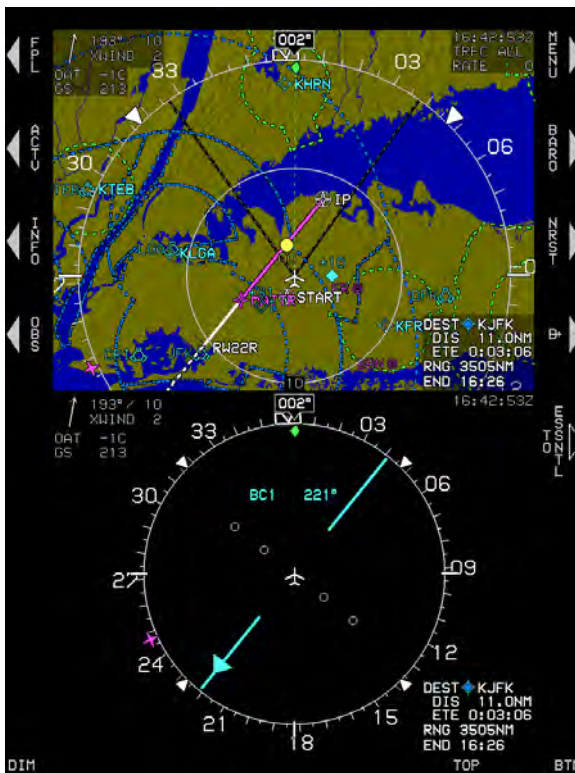

Figure 2-11: MFD Normal Mode

TAWS popups: When an FLTA alert is generated, a popup function enables PFI SVS and activates terrain at an appropriate scale and format on the moving map page (one of the multi-function pages). This is a required function of TSO-C151b for TAWS Class A, B, and C depending on aircraft configuration and external sensors or switches. (See Section 8 TAWS for more information.)

Traffic popups: When a traffic alert is generated, a popup function displays traffic on the PFI and moving map page and the traffic thumbnail on the PFI (see Traffic appendix for more information).

2.3.2. Data Source Monitors

In installations with redundant sensors, IDUs continuously monitor the following sensors to detect disagreements:

- 1) Airspeed
- 2) Altitude
- 3) Attitude

- | | |
|--|--|
| 4) Barometric setting (pilot vs. co-pilot sides) | 6) Heading |
| 5) GPS position, track, and groundspeed | 7) Localizer and glideslope deviations |
| | 8) Radar altitude |

2.3.3. IDU Intra-System Communications

Communication between IDUs installed on the same side is referred to as intra-system communications. In a two-sided system (pilot and co-pilot) configuration, the crosslink side-to-side communications is referred to as inter-system communications. IDUs on the same side (pilot side and co-pilot side individually) monitor each other using intra-system communications and perform the following checks:

- | | |
|--|---|
| 1) Intra-system communications freshness | 6) Barometric setting agreement |
| 2) Screen counter incrementing (i.e., screen not frozen) | 7) GPS position, track, and groundspeed agreement |
| 3) Airspeed agreement | 8) Heading agreement |
| 4) Altitude agreement | 9) Localizer and glideslope deviation agreement |
| 5) Attitude agreement | 10) Radar altitude agreement |

2.4. Color Conventions

The EFIS uses a consistent set of colors to display information. Any color representation may not be identical as it appears on the IDU.

Table 2-4: Color Conventions

Color	Use(s)	Examples
WHITE 	Items set by pilot and held by the EFIS or items where device feedback is not expected; marker beacon receiver high/low sensitivity modes; scales, associated labels and figures; pilot action; or data entry. When used for an analog bar indication, light gray (low-intensity white) is used instead, as a large white area on the screen may be overwhelming.	Scales markings (airspeed, altitude, heading, VSI, pitch, map ranges, etc.) Pilot-selected values (airspeed, heading, altitude) Secondary flight data (TAS, wind, OAT, timers, etc.)

Table 2-4: Color Conventions











Color	Use(s)	Examples
CYAN 	VOR #1 and IFR navigation dataset items. Information received from the device that is not related to a pilot setting.	Airports with instrument approach procedures, VORs, and intersections.
MAGENTA 	Indicates calculated or derived data and certain navigation database items. Light magenta for visibility	Active waypoint related symbols. Course data (desired track, CDI). VFR airports, NDBs, VNAV altitudes, ACTV freq/codes, operating modes, and transmit enable indications.
GRAY 	Background for airspeed and altitude readout and for conformal runway depiction Light gray for usable portion of active runway, dark gray for other runway surfaces	
GREEN 	VOR #2 and to indicate normal or valid operation (airspeed, altitude tape coloring, status indication, etc.) Light green for visibility.	Aircraft ground track, skyway symbology, and airspeeds in green arc.
DARK GREEN 	Terrain indication on moving map (slope between adjacent terrain determines the shade used).	
AMBER (YELLOW) 	Identifies conditions requiring immediate pilot awareness and possible subsequent action. Currently used for DME hold indications.	
OLIVE 	In various shades shows terrain within 2000' and below aircraft altitude.	
BROWN 	In a variety of shades indicates earth/terrain portion of PFD or when above 100 feet less than aircraft altitude on MFD.	

Table 2-4: Color Conventions

Color	Use(s)	Examples
BLUE 	In a variety of shades indicates sky portion of PFD, bodies of water on moving map.	
RED 	Indicates aircraft limitations or conditions, which require immediate pilot action, or a device failure (red "X").	
BLACK 	Field of view angle lines on moving map, figures on a gray background, and outlining borders and certain figures/elements on backgrounds with minimal contrast, e.g., airspeed, altitude, and menu tiles on the PFD/MFD.	

2.5. AHRS Fast Slave and Erect

If it becomes necessary to restore the heading and attitude references, the AHRS includes heading fast slave and attitude fast erect features, which can be performed when in approximately straight and level flight to ensure the best chance of providing valid observation for heading and attitude. See AFMS for nomenclature and location of switch or button.

2.6. Warning/Caution/Advisory System

The IDU has an integrated audio/visual warning system, which monitors a wide variety of parameters and provides alerts for conditions that demand pilot action or awareness.

The following alerts are provided and described below:

- 1) Warning Alerts
- 2) Time-Critical Warning Alerts
- 3) Master Visual and Audible/Voice Alerts
- 4) Caution Alerts
- 5) Advisory Alerts

All warnings, including time-critical warnings, activate the warning (red) light and master caution light. All cautions, including time-critical cautions, activate the caution (yellow) light and master caution light. Once acknowledged, the flashing behavior stops, the audible alert is interrupted, and the discrete outputs are deactivated.

2.6.1. Time-Critical Warning and Caution Alerts

Time-critical warning and caution alerts trigger the following elements (Table 2-5) and display in the pilot’s primary field of view with a shaded background (Figure 2-12). EFIS limits may have enabled the option for time-critical alerts to illuminate a master warning/master caution push button annunciator when equipped.

NOTE:

When an IDU is in essential mode, the system exits an open menu whenever time-critical caution or warning alerts are triggered.

In the following tables, examples show shaded backgrounds on sky and terrain backgrounds for readability.



Figure 2-12: Time-Critical Warning and Caution Alerts

Table 2-5: Time-Critical Warning and Caution Alerts in Primary Field of View

Alert Type	Text Color	Flash Rate	Audio Alert at Full Volume
WARNING	Red	2 Hz	Repeated until acknowledged
WARNING			
CAUTION	Amber (Yellow)	1 Hz	Plays only once
CAUTION			

Table 2-6: Time-Critical Warning and Caution Alerts





















Visual Alert	Voice Alert	Condition ** No time delay
 	“Overspeed, Overspeed”	IAS exceeds redline ($V_{NE}/V_{MO}/M_{MO}$) plus instrument error. **
 	“Stall, Stall”	Activated above 100’ AGL if indicated airspeed is below the higher of V_{S1} or V_{S1} corrected for G-load + 5 KIAS. Deactivated if stall-warning flag is set to 0.
 	“Terrain, Terrain, Pull Up, Pull Up”	Terrain cell within TAWS FLTA warning envelope. Half-second time delay. Within GPWS 2 warning envelope. Half-second time delay.
	“Pull Up, Pull Up”	Within GPWS Mode 1 warning envelope. Half-second time delay.
 	“Glideslope, Glideslope”	Within GPWS Mode 5 warning envelope. Half-second time delay.
 	“Warning Obstruction, Warning Obstruction”	Obstruction within TAWS FLTA warning envelope. Half-second time delay.
 	“Traffic, Traffic”	Resolution advisory. Not given if own aircraft at or below 400’ AGL. Not given if target is at or below 200’ AGL (ground target). Audio not generated with TCAS-II system. **
 	“Check Gear, Check Gear”	Activates if aircraft is below 500’ AGL, is descending, and is below V_{FE} ; and any landing gear is not down. 2-second time delay.
 	“Caution Terrain, Caution Terrain”	Within GPWS Mode 2 caution envelope. Half-second time delay.
		Terrain cell within TAWS FLTA caution envelope. Half-second time delay.
 	“Sink Rate, Sink Rate”	Within GPWS Mode 1 caution envelope. Half-second time delay.
 	“Too Low Terrain, Too Low Terrain”	Within GPWS Mode 3 envelope. Half-second time delay.
		Within GPWS Mode 4-1 “Too Low Terrain” envelope. Half-second time delay.
		Within TAWS PDA envelope. Half-second time delay.

Table 2-6: Time-Critical Warning and Caution Alerts

Visual Alert	Voice Alert	Condition ** No time delay
	“Too Low Gear, Too Low Gear”	Within GPWS Mode 4-2 “Too Low Gear” envelope. Half-second time delay.
	“Too Low Flaps, Too Low Flaps”	Within GPWS Mode 4-3 “Too Low Flaps” envelope. Half-second time delay.
GLIDESLOPE GLIDESLOPE	“Glideslope, Glideslope”	Within GPWS Mode 5 caution envelope. Half-second time delay.
OBSTRUCTION OBSTRUCTION	“Caution Obstruction, Caution Obstruction”	Obstruction within TAWS FLTA caution envelope. Half-second time delay.
TRAFFIC TRAFFIC	“Traffic, Traffic”	Not given if own aircraft below 400’ AGL nor if target is below 200’AGL (ground target). **

Time-critical warning and caution alerts are prioritized so only one alert at a time is active.

- | | |
|------------------------|---|
| 1) Stall | 12) GPWS Mode 4-2 |
| 2) Overspeed | 13) GPWS Mode 4-3 |
| 3) GPWS Mode 1 Warning | 14) GPWS Mode 1 Caution |
| 4) GPWS Mode 1 Warning | 15) GPWS Mode 2 Caution |
| 5) GPWS Mode 2 Warning | 16) GPWS Mode 3 |
| 6) TAWS FLTA Warning | 17) GPWS Mode 5 Warning |
| 7) Obstruction Warning | 18) GPWS Mode 5 Caution |
| 8) TAWS FLTA Caution | 19) Check Gear |
| 9) Obstruction Caution | 20) Traffic Warning (Resolution Advisory) |
| 10) GPWS Mode 4-1 | 21) Traffic Caution (Traffic Advisory) |
| 11) TAWS PDA. | |

2.6.2. Warning Alerts

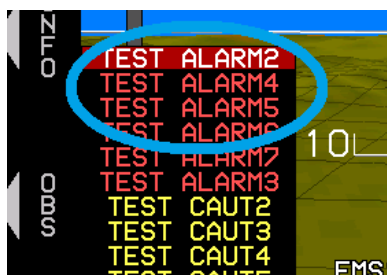

Figure 2-13: Warning Alerts

Table 2-7: Warning Alert Elements

Type Alert	Location	Flash Rate	Audio Alert
 	PFD lower left corner of transmit enabled IDU	2 Hz	Repeated until acknowledged

Table 2-8: Warning Alerts

Visual Alert	Voice Alert	Condition ** No time delay
	“Fuel Low, Fuel Low”	One of the following conditions is true: <ol style="list-style-type: none"> 1) A low fuel warning discrete input is active 2) A sensed fuel tank quantity is below its low fuel warning threshold 3) Total aircraft fuel is below the pilot-set emergency fuel threshold. 1-minute time delay.
	“Overspeed, Overspeed”	Indicated airspeed exceeds redline ($V_{NE}/V_{MO}/M_{MO}$ as appropriate) plus instrument error. **
	“Stall, Stall”	Activated above 100' AGL if IAS is below the higher of V_{S1} or V_{S1} corrected for G-load + 5 kts. Deactivated if stall-warning flag is set to 0. **

Used on IDU #0 only. Duplicate time-critical warning alerts covers the case where IDU #0 is not displaying the PFI.

Table 2-8: Warning Alerts

Visual Alert	Voice Alert	Condition ** No time delay
PULL UP	"Pull Up, Pull Up"	Within GPWS Mode 1 warning envelope. Half-second time delay.
	"Terrain, Terrain, Pull Up, Pull Up"	Terrain cell within TAWS FLTA warning envelope. Half-second time delay.
GLIDESLOPE	"Glideslope, Glideslope"	Within GPWS Mode 2 warning envelope. Half-second time delay.
OBSTRUCTION	"Warning Obstruction, Warning Obstruction"	Within GPWS Mode 5 warning envelope. Half-second time delay.
TRAFFIC	"Traffic, Traffic"	Obstruction within TAWS FLTA warning envelope. Half-second time delay.
		Resolution advisory. Not given if own aircraft at or below 400' AGL. Not given if target is at or below 200' AGL (ground target). Audio not generated with TCAS-II system. **

2.6.3. Caution Alerts

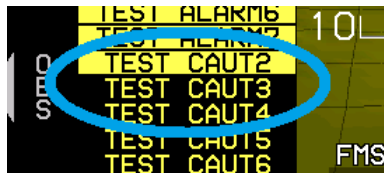

Figure 2-14: Caution Alerts

NOTE:

With an OASIS EICAS page configured, it is possible for the EICAS page to generate these caution alerts.

Table 2-9: Caution Alert Elements

Type Alert	Location	Flash Rate	Audio Alert
CAUTION	PFD lower left corner of transmit enabled IDU	1 Hz	Plays only once
CAUTION			

Table 2-10: Caution Alerts

Visual Alert	Voice Alert/ Alert Tone	Condition
** No time delay ^[1] Only active in dual-sensor installation with neither sensor in failure condition ^[2] Only active in dual-side (pilot and co-pilot) ^[3] Only active when single-pilot mode discrete not asserted		
ADC1 FAIL ADC2 FAIL ADC1/2 FAIL	Alert Tone	Indicates no valid IAS, pressure altitude, nor VSI received from numbered ADC(s) for more than 1 second. ** ^[1]
ADS-B FAIL	Alert Tone	Enabled by ADS-B out fail warning limits setting. Mode-S transponder indicates bad ADS-B out status. Also, set by audio/radio interface with NGT-9000R transponder. 2-second time delay.
AHRS1 FAIL AHRS2 FAIL AHRS1/2 FAIL	Alert Tone	Indicates no valid bank, pitch, nor heading received from enumerated AHRS(s) for more than 1 second. Inhibited during and for 10 seconds after unusual attitude mode. ** ^[1]
AUX SENSOR	“Auxiliary Sensor Failure, Auxiliary Sensor Failure”	No valid message or bad status received from installed optional sensors. Sensor status displayed in faults menu. 5-second time delay. Inhibited during and for 10 seconds after unusual attitude mode. Applies to the following optional sensors: 1) RS-232 TAS 2) ADS-B system 3) WX-500 Lightning system 4) Analog interface system
PLT1 OVRTMP PLT2 OVRTMP PLT3 OVRTMP PLT4 OVRTMP CPLT1 OVRTMP CPLT2 OVRTMP CPLT3 OVRTMP CPLT4 OVRTMP	Alert Tone	IDU core temperature greater than 95°C. 2-second time delay.
PLT MISCOMP CPLT MISCOMP	Alert Tone	Only when fresh intra-system monitor messages are received. Indicates critical parameters used by displays on

Table 2-10: Caution Alerts

Visual Alert	Voice Alert/ Alert Tone	Condition
		<p>the indicated side exceed miscompare thresholds. Compares the following critical parameters:</p> <ol style="list-style-type: none"> 1) Attitude (pitch and roll) 2) Heading 3) Pressure altitude 4) Indicated airspeed 5) Localizer (both inputs) 6) Glideslope (both inputs) 7) Radar altitude 8) Latitude 9) Longitude 10) Track 11) Groundspeed <p>1-second time delay. Inhibited during and for 10 seconds after unusual attitude mode. ^[2]</p>
ALT MISCOMP	Alert Tone	<p>Indicates pressure altitude difference between ADCs is beyond limits. 10-second time delay. Inhibit for 5 minutes after startup. ^[1]</p>
ATT MISCOMP	Alert Tone	<p>Indicates pitch or roll difference between AHRS is beyond limits (6°). 10-second time delay. Inhibit for 5 minutes after startup. ^[1]</p>
CHECK TRIM↓	"Check Pitch Trim"	<p>Pitch mis-trimmed for more than 3 continuous seconds (trim not responding). Trim is needed in indicated direction.</p>
CHECK TRIM↑		
PLT RANGE CPLT RANGE	"Check Range, Check Range"	<p>Based upon flight plan in use on the indicated side, less than 30 minutes buffer (at current groundspeed) between calculated range and distance to:</p> <ol style="list-style-type: none"> 1) last waypoint if it is active; or 2) airport if on a missed approach; or

Table 2-10: Caution Alerts

Visual Alert	Voice Alert/ Alert Tone	Condition
		3) along-route distance to destination. Not activated in climbing flight nor if below 60 kts groundspeed. 5-minute time delay.
GPS1 FAIL GPS2 FAIL GPS1/2 FAIL	Alert Tone	Indicates no valid message received from numbered GPS/SBAS for more than 5 seconds. Inhibited during and for 10 seconds after unusual attitude mode. ** [1]
PLT1 SCC PLT2 SCC PLT3 SCC PLT4 SCC CPLT1 SCC CPLT2 SCC CPLT3 SCC CPLT4 SCC	Alert Tone	Indicates personality module for designated IDU (side and IDU #) could not be read upon power-up. Internal limits are in use by the system. Only active on the ground.
PLT1 TAWS PLT2 TAWS PLT3 TAWS PLT4 TAWS CPLT1 TAWS CPLT2 TAWS CPLT3 TAWS CPLT4 TAWS	Alert Tone	Indicates on the designated IDU (side and IDU #), aircraft is currently beyond extent of terrain database or a failure condition is preventing TAWS FLTA function from operating. Half-second time delay. Inhibited during and for 10 seconds after unusual attitude mode.
COOLING FAN	Alert Tone	Triggered when external cooling fan is commanded on by discrete output, but the cooling fan status discrete input indicates the cooling fan is not rotating. 1-minute time delay.
FUEL SPLIT	Alert Tone	Compares the volume of fuel designated left wing tank fuel vs. volume of fuel designated right wing tank fuel to the fuel split caution threshold. Issued if the difference exceeds the fuel split caution threshold. Only performed if the fuel split caution threshold is non-zero and both left and right wing tank fuel is monitored and valid. 1-minute time delay.
LOW FUEL	"Fuel Low, Fuel Low"	A low fuel warning is not active and one of the following conditions is true:

Table 2-10: Caution Alerts

Visual Alert	Voice Alert/ Alert Tone	Condition
		<ol style="list-style-type: none"> 1) One of the low fuel caution discrete inputs is active 2) One of the sensed fuel tank quantities is below its low fuel caution threshold 3) Total aircraft fuel is below the pilot-set minimum fuel threshold 1-minute time delay.
GPS MISCOMP	Alert Tone	Indicates position, track, or groundspeed difference between GPS/SBAS units is beyond the following limits: Position: Enroute Mode 4NM Terminal Mode 2NM Departure Mode .6NM IFR Approach Mode .6NM VFR Approach Mode .6NM Track: If groundspeed is greater than 30 kts, miscompare if difference is more than 4°. Groundspeed: If difference between GPS#1 and GPS#2 miscompare is more than 10 kts. 10-second time delay. Inhibited during and for 10 seconds after unusual attitude mode. ^[1]
GS MISCOMP	Alert Tone	Indicates at least one glideslope is receiving a signal within 1 dot of center and difference between glideslope signals is beyond limits (0.25 dots). 10-second time delay. ^[1]
HDG MISCOMP	Alert Tone	With neither AHRS failed nor in DG mode. Indicates heading difference between AHRS is beyond heading miscompare threshold limit. 60-second delay. Inhibited during and for 10 seconds after unusual attitude

Table 2-10: Caution Alerts

Visual Alert	Voice Alert/ Alert Tone	Condition
		mode. Inhibit for 5 minutes after startup. ^[1]
IAS MISCOMP	Alert Tone	Indicates IAS difference between ADCs is beyond limits. 10-second time delay. Inhibit for 5 minutes after startup. ^[1]
LOC MISCOMP	Alert Tone	Indicates at least one localizer is receiving a signal within 1 dot of center and difference between localizer signals is beyond limits (0.25 dots). 10-second time delay. ^[1]
RALT MISCOMP	Alert Tone	Indicates radar altitude difference between radar altimeters is beyond limits. 10 second time delay. Limits are as follows: >= 500'AGL Δ 14% 100 – 500'AGL Δ 10% < 100'AGL Δ 10' ^[1]
OAT FAIL OAT1 FAIL OAT2 FAIL OAT1/2 FAIL	Alert Tone	OAT FAIL applicable to single ADC installation. OAT# FAIL applicable indicates OAT indication is invalid but other air data parameters are normal (i.e., air data not red-X'd) ^[1] . Half-second time delay.
RALT FAIL RALT1 FAIL RALT2 FAIL RALT1/2 FAIL	Alert Tone	RALT FAIL applicable to single radar altimeter installation. RALT# FAIL applicable to dual radar altimeter installation. For analog radar altimeter, indicates the aircraft is below 2000' AGL in air mode without a valid radar altimeter reading. For ARINC 429 radar altimeter, indicates an SSM of failure warning is transmitting. 2-second time delay.
TAWS INHBT	Alert Tone	TAWS inhibited through use of discrete input. **
TCAS FAIL	Alert Tone	TAS indicates lack of communications with system or failure indication from system. **
TOTALZR QTY	Alert Tone	Compares the volume of sensed fuel to the fuel totalizer calculation. Issued if

Table 2-10: Caution Alerts

Visual Alert	Voice Alert/ Alert Tone	Condition
		the difference exceeds the totalizer mismatch caution threshold. Only performed if: <ol style="list-style-type: none"> 1) Totalizer mismatch caution threshold is non-zero; 2) Fuel totalizer is enabled; 3) Unmonitored fuel flag is false; 4) Fuel totalizer has a valid value; and 5) Fuel levels are valid. 1-minute time delay.
TRIM MOTION↓	"Trim in Motion, Trim in Motion"	Pitch trim running for more than a preset amount of time in indicated direction.
TRIM MOTION↑		
XFILL FAIL	Alert Tone	Indicates lack of inter-system communications. 32-second delay. ^{[2][3]}
<i>Used on IDU #0 only. Duplicate time-critical caution alerts covers the case when IDU #0 is not displaying the PFI.</i>		
CHECK GEAR	"Check Gear, Check Gear"	Activates if aircraft is below 500' AGL, is descending, and is below V_{FE} ; and any landing gear is not down. 2-second time delay.
TERRAIN	"Caution Terrain, Caution Terrain"	Terrain cell within TAWS FLTA caution envelope. Half-second time delay.
		Within GPWS Mode 2 caution envelope. Half-second time delay.
SINK RATE	"Sink Rate, Sink Rate"	Within GPWS Mode 1 caution envelope. Half-second time delay.
TOO LOW	"Too Low Terrain, Too Low Terrain"	Within GPWS Mode 3 envelope. Half-second time delay.
		Within GPWS Mode 4-1 "Too Low Terrain" envelope. Half-second time delay.
		Within TAWS PDA envelope. Half-second time delay.
	"Too Low Gear, Too Low Gear"	Within GPWS Mode 4-2 "Too Low Gear" envelope. Half-second time delay.

Table 2-10: Caution Alerts

Visual Alert	Voice Alert/ Alert Tone	Condition
	“Too Low Flaps, Too Low Flaps”	Within GPWS Mode 4-3 “Too Low Flaps” envelope. Half-second time delay.
GLIDESLOPE	“Glideslope, Glideslope”	Within GPWS Mode 5 caution envelope. Half-second time delay.
OBSTRUCTION	“Caution Obstruction, Caution Obstruction”	Obstruction within TAWS FLTA caution envelope. Half-second time delay.
TRAFFIC	“Traffic, Traffic”	Not given if own aircraft below 400’ AGL nor if target is below 200’ AGL (ground target). **

2.6.4. Side-Specific Caution Alerts

Side-specific caution alerts are displayed on all IDUs on a side that detect a failure on an IDU on that side.

Table 2-11: Side-Specific Caution Alerts

Visual Alert	Alert Tone	Condition ** No time delay
CHECK IDU 1	Alert Tone	IDU status has not been received from another same-side IDU in the last second \pm 0.1 seconds. # indicates which IDU is failing the check. **
CHECK IDU 2		
CHECK IDU 3		
CHECK IDU 4		

2.6.5. Advisory Alerts

Figure 2-15: Advisory Alerts
Table 2-12: Advisory Alert Elements

Type Alert	Location	Appearance	Audio Alert
ADVISORY	PFD lower left corner of transmit enabled IDU	While condition persists	Single advisory chime played at 80% volume

Table 2-13: Advisory Alerts

Visual Alert	Alert Tone	Condition
** No time delay		
[1] Only active in dual-sensor installation with neither sensor in failure condition		
[2] Only active in dual-side (pilot and co-pilot)		
[3] Only active when single-pilot mode discrete not asserted		
ADC INIT ADC1 INIT ADC2 INIT ADC1/2 INIT	Chime	Indicates ADC# not at full accuracy during warm-up. ** ADC1 INIT, ADC2 INIT, and ADC1/2 INIT [1]
AHRS1 DG AHRS2 DG AHRS1/2 DG	Chime	Indicates numbered AHRS in DG mode. ** [1]
CREW CALL	Chime	Only active with EFIS control of an audio controller and call notice is received from the controller.
PLT1 PWR PLT2 PWR PLT3 PWR PLT4 PWR CPLT1 PWR CPLT2 PWR CPLT3 PWR CPLT4 PWR	Chime	Indicates a dual redundant power supply within the designated IDU (side and IDU #) is not functioning correctly. Only active on the ground. 1-minute time delay.
FPM INHBT	Chime	Flight path marker inhibit function activated through use of momentary discrete input. **
BARO MISCOMP	Chime	Indicates mismatch of altimeter settings or altimeter modes between sides. 10-second time delay. [2] [3]
SAME ADC	Chime	Indicates both sides are operating from same ADC source. ** [1]
SAME RALT	Chime	Indicates both sides are operating from same radar altimeter source. ** [1][2][3]
SAME NAV	Chime	Indicates both sides are operating from same navigation source. ** [1][2][3]
SAME GPS	Chime	Indicates both sides are operating from same GPS/SBAS source. ** [1][2][3]
SAME DME	Chime	Indicates both sides are operating from same DME source ** [1] [3]
SAME AHRS	Chime	Indicates both sides are operating from same AHRS source. [1]
TAS INHBT	Chime	TAS aural inhibited through activation of TCAS/TAS audio inhibit discrete input. **

Table 2-13: Advisory Alerts

Visual Alert	Alert Tone	Condition
** No time delay [1] Only active in dual-sensor installation with neither sensor in failure condition [2] Only active in dual-side (pilot and co-pilot) [3] Only active when single-pilot mode discrete not asserted		
TAWS GS CNX	Chime	(Class A TAWS) TAWS glideslope cancel (GPWS Mode 5) activated through use of discrete input. **
TCAS STBY	Chime	Only active with TCAS-II. Indicates system is either in standby or executing functional test in flight. **
TA ONLY	Chime	Only active with TCAS-II. Indicates system is unable to display resolution advisories. **
TCAS TEST	Chime	Only active with TCAS-II. Indicates system is in functional test on ground. **
XFILL ARM	Chime	With good inter-system communications and crossfill not inhibited, indicates sides are not synchronized and synchronized function is available. ** [2] [3]
XFILL INHBT	Chime	With good inter-system communications, indicates crossfill is inhibited through discrete input. ** [2] [3]

2.6.6. Side-Specific Advisory Alerts

Side-specific advisory alerts have the same characteristics as advisory alerts, except they always appear in the lower-left corner of the transmit enabled IDU PFI (if showing) or lower-left corner of the transmit enabled IDU bottom area (PFI not showing).

These type of alerts are used where the pilot and co-pilot sides can generate different alerts, such as when the pilot and co-pilot sides are not crossfilled and are operating on different FMS flight plans.

Table 2-14: Side-Specific Advisory Alerts

Visual Alert	Alert Tone	Condition ** No time delay
CHK BARO	Chime	Ascending through transition level: Altimeter not set to 29.92 inHg or 1013 mbar.

Table 2-14: Side-Specific Advisory Alerts

Visual Alert	Alert Tone	Condition ** No time delay
		Descending through transition level: Altimeter set to 29.92 inHg or 1013 mbar. Descent warning times out in 10 seconds. Disabled during QFE operation. 2-second time delay.
ANP: 0.01 ANP: 15.0	Chime	GPS/SBAS actual navigation performance in nautical miles based upon current GPS/SBAS HPL. Value ranges from 0.01 to 15.0 NM.
RNP: 0.10A RNP: 15.0A	Chime	GPS/SBAS automatic required navigation performance in nautical miles as acquired from navigation database. Value ranges from 0.01 to 15.0 NM.
RNP: 0.10M RNP: 15.0M	Chime	GPS/SBAS manual required navigation performance in nautical miles as set by pilot. Value ranges from 0.10 to 15.0 NM.
DR 00:00 DR 01:23	Chime	GPS/SBAS in dead reckoning mode with valid ADC and AHRS data. Timer shows time since loss of position (mm:ss) to indicate quality of DR solution. ** Inhibited during and for 10 seconds after unusual attitude mode. Valid range is from 00:00 to 59:59.
LNAV APPR	Chime	GPS/SBAS in LNAV approach mode.**
LNU/UNU APPR	Chime	GPS/SBAS in LNAV/VNAV approach mode. **
LP APPR	Chime	GPS/SBAS in LP approach mode. **
LPU APPR	Chime	GPS/SBAS in LPV approach mode.**
SUSPEND	Chime	Automatic waypoint sequencing is suspended under any of the following conditions: ** <ol style="list-style-type: none"> 1) Pilot has selected a manual GPS/SBAS OBS. 2) Active waypoint is the missed approach waypoint, and missed approach procedure has not been armed (ARM) nor initiated (MISS). 3) Aircraft is in a published or manually created holding pattern, and pilot has

Table 2-14: Side-Specific Advisory Alerts

Visual Alert	Alert Tone	Condition ^{**} No time delay
		not chosen to continue (CONT) out of the holding pattern. 4) Leg following active waypoint is a manual termination leg, and the pilot has not chosen to resume (RESUME) to the waypoint following the manual termination. 5) The aircraft is in a repeating SAR pattern (see SAR appendix), and the pilot has not chosen to continue out of the SAR pattern.**
TERMINAL	Chime	GPS/SBAS in terminal mode.**
VFR APPR	Chime	GPS/SBAS in VFR approach mode.**
VECTORS	Chime	GPS/SBAS in vectors to final approach mode prior to sequencing FAWP.**
PTK = L 1NM PTK = L 20NM PTK = R 1NM PTK = R 20NM PTK ENDING	Chime	GPS/SBAS parallel offset path advisory. ## is nautical miles left (L) or right (R) of main path. PTK ENDING if within the parallel offset distance from a parallel offset exit waypoint.**
FLTA INHBT	Chime	Shown when FLTA function is automatically inhibited during normal operation. TAWS INHBT advisory has priority.**
TRUE NORTH	Chime	System operating in true north mode.**
VNAV AVAIL	Chime	Only active with Genesys/S-TEC DFCS. Indicates VNAV guidance is available but not currently in use by the AP. Press "VNV" button on mode control panel to engage VNAV mode.

2.6.7. Audio-Only Caution and Advisory Alerts

Audio-only caution alerts trigger a single audio message played at full volume, whereas audio-only advisory alerts are played at 80% of full volume.

Table 2-15: Audio-Only Caution and Advisory Alerts



Caution or Advisory Alert	Voice Alert/ Alert Tone	Condition ** No time delay
Minimum Altitude Caution Alert	“Minimums, Minimums”	Deviation from above to below minimum altitude bug. Minimum altitude readout turns amber (yellow) and flashes. **
Selected Altitude Deviation Caution Alert	“Altitude, Altitude”	Deviation greater than 150’ from selected altitude after capture (within 100’ of altitude). 2-second time delay.
VNAV Altitude Deviation Caution Alert		If not on a descending VNAV profile, deviation greater than 150’ from altitude of the current or prior VNAV waypoint after capture (within 100’ of altitude). 2-second time delay.
Decision Height Caution Alert	“Decision Height”	Deviation from above to below decision height bug. Decision height readout turns amber (yellow) and flashes. **
GBS/SBAS Failure Caution Alert	Alert Tone	No valid position data available from selected GPS/SBAS for more than 5 seconds and dead reckoning not available. Inhibited during and for 10 seconds after unusual attitude mode. Loss of position data is obvious from symbology changes associated with reversionary modes. **
GPS/SBAS Loss of Integrity Caution Alert	Alert Tone	GPS/SBAS loss of integrity caution. Inhibited during and for 10 seconds after unusual attitude mode. LOI indication is integrated with lateral deviation indicator. ** 
GPS/SBAS Loss of Navigation Caution Alert	Alert Tone	GPS/SBAS loss of navigation caution. Inhibited during and for 10 seconds after unusual attitude mode. LON indication is integrated with lateral deviation indicator. ** 
Loss of Vertical Navigation Caution Alert	Alert Tone	Loss of vertical navigation caution. Inhibited during and for 10 seconds after unusual attitude mode. VLON indication is integrated with vertical deviation indicator. ** 

Table 2-15: Audio-Only Caution and Advisory Alerts

Caution or Advisory Alert	Voice Alert/Alert Tone	Condition ** No time delay
Autopilot Disconnect Advisory Alert	“Autopilot Disconnect”	Sounds when autopilot servos disengage for any reason. (Genesys/S-TEC DFCS is installed)
Autopilot Failure Advisory Alert	“Autopilot Failure”	Sounds when autopilot failure is detected. (Genesys/S-TEC DFCS is installed)
Countdown Timer Chime	Chime	Sounds when countdown timer reaches 00:00:00. **
Level-off Advisory Alert	Altitude Alert Tone	Within the greater of 1000’ or 50% of VSI from uncaptured selected or VNAV waypoint altitude. Inhibited in approach procedures. **
GPWS Mode 6 Advisory Alert	“Five Hundred”	Descending through 500’ AGL advisory. Armed upon climbing through deadband value above 500’ AGL. Half-second time delay.

2.6.8. Voice Alerts and Muting

Only the highest priority (in criticality and recency), unacknowledged voice alert is played at any given time. Any playing audio message is immediately muted by activating the warning/caution acknowledge switch.

2.6.9. Visual Alert Prioritization and Declutter

Visual alerts are visually prioritized, so warnings are displayed above cautions, which are displayed above advisories. Within categories, visual alerts are stacked in chronological order, so the most recent alert appears on top.

The maximum number of visual alerts that can be simultaneously displayed in the standard location is 11. In the event there are more than 11 visual alerts, **MORE-PRS MENU** appears for guidance in accessing the EXPAND CAS menu.

Only the highest priority (in criticality and recency), unacknowledged audible annunciation is played at a time. In addition, to further minimize cockpit confusion, annunciations are grouped and prioritized so only one annunciation is active.

In addition, flags are decluttered from all IDUs, which are not “transmit enabled.” Only IDU-specific flags (i.e., CHECK IDU #) appear on these IDUs.

2.7. Database and Software Updates

2.7.1. Navigation and Obstruction Database

The EFIS uses Jeppesen Sanderson NavData® for the navigation database and Jeppesen Sanderson obstacle data for the obstruction database.

Visit www.jeppesen.com to place the order for the correct database.

NOTE:

When ordering, review the EFIS Equipment-Database Compatibility Matrix (Document 01-000062) on the Genesys Aerosystems website. This document specifies the compatibility of Genesys Aerosystems EFIS equipment and software versions to navigation database versions.

Three available coverage areas of navigation databases may be used on this EFIS:

Americas - Major airports and navigation for Alaska, Canada, Continental U.S., Hawaii, Puerto Rico, Bahamas, Bermuda, Mexico, Central, and South America.

International - All available coverage except North and South America.

World - Major airports and navigation with the Americas.

The updateable navigation database contains at least the following location and path information, referenced to WGS-84, with a resolution of 0.01 minute (latitude/longitude) and 0.1° (for course information) or better at all of the following for the area(s) in which IFR operations are intended:

- 1) Airports.
- 2) VORs, DMEs (including DMEs collocated with localizers), collocated VOR/DMEs, VORTACs, and NDBs (including NDBs used as locator outer marker).
- 3) All named waypoints and intersections shown on enroute and terminal area charts.
- 4) All airways shown on enroute charts, including all waypoints, intersections, and associated RNP values (if applicable). Airways are

retrievable as a group of waypoints (select the airway by name to load the appropriate waypoints and legs between desired entry and exit points into the flight plan).

- 5) RNAV DPs and STARs, including all waypoints, intersections, and associated RNP values (if applicable). DPs and STARs are retrievable as a procedure (select the procedure by name to load the appropriate waypoints and legs into the flight plan).
- 6) LNAV approach procedures in the area(s) in which IFR operation is intended consist of:
 - a) Runway number and label (required for approach identification);
 - b) Initial approach waypoint (IAWP);
 - c) Intermediate approach waypoint(s) (IWP), when applicable;
 - d) Final approach waypoint (FAWP);
 - e) Missed approach waypoint (MAWP);
 - f) Additional missed approach waypoints, when applicable; and
 - g) Missed approach holding waypoint (MAHWP).

The complete sequence of waypoints and associated RNP values (if applicable), in the correct order for each approach, is retrievable as a procedure (select the procedure by name to load the appropriate waypoints and legs into the flight plan). Waypoints utilized as a final approach waypoint (FAWP) or missed approach waypoint (MAWP) in an LNAV approach procedure are uniquely identified as such (when appropriate) to provide proper approach mode operation.

- 7) LNAV/VNAV procedures in the area(s) where IFR operation is intended. LPV, LP, and/or LNAV/VNAV published procedures are available. Select a procedure by name to load the appropriate waypoints and legs into the active flight plan. Waypoints used as a final approach waypoint (FAWP) and LTP/FTP/MAWP in an LNAV/VNAV procedure are uniquely identified as such to provide proper approach mode operation.

The obstruction database is distributed by a government agency in each country. Not all countries have obstruction databases available.

2.7.2. Update Requirements

Scheduled updates for databases are as follows:

- 1) Navigation Database - Every 28 days

- 2) Obstruction Database - Every 28 days
- 3) MAGVAR Database - Every 5 years (updated as described in a Genesys Aerosystems service bulletin)

CAUTION:

Failure to update the EFIS with the correct NavData® causes the IDU to remain in continual reboot mode and does not allow any display page to appear.

The EFIS is updated through the ground maintenance function (GMF). To gain access to the GMF, prior to applying power, slide the slip indicator or non-slip blank door cover at the bottom-center of the IDU bezel upward to the first detent position to expose the USB port.

When an update is performed, the following procedures must be performed separately on every IDU installed in the aircraft.

To update the databases:

- 1) Load the navigation database (navdata.exe) and obstruction database (obst.exe) on USB flash drive.
- 2) With the power off, insert the USB flash drive into USB port.

CAUTION:

Always install a valid USB flash drive in the IDU prior to activating any ground maintenance function. Operation of the GMF without a valid USB flash drive installed may cause erroneous failure indications or corruption of the IDU.

- 3) Turn on power to gain access to the GMF page.
- 4) Rotate **1** to **Update Databases** and push to enter.

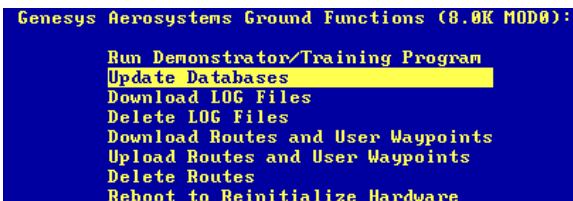

Figure 2-16: Ground Maintenance Page

- 5) Once each database is loaded, press any button to continue to complete the process.
- 6) Once both databases have been uploaded, power down the IDU, remove the USB flash drive, and lower the USB door.
- 7) Once each IDU has been updated, power up the entire EFIS in normal flight mode and verify each IDU successfully updated with the latest database by noting the new navigation database and obstruction database cycle expiration dates before acknowledging the initialization screen (Figure 2-4). Because the obstruction database is advisory in nature, there technically is no expiration date. The listed date is the effective date of the next available obstruction database.
- 8) A cyclic redundancy check (CRC) self-test verifies the data at every step of the process, thereby ensuring the data installed into the system has not been corrupted at any point during the process.

2.7.3. Software and Terrain Database Update

Updates and terrain database updates are provided on an as-needed basis and performed as per a service bulletin.

2.8. Demonstrator

The EFIS has a built-in demonstration application to fly anywhere in the world while performing any procedure (except takeoff and landing) based on the current Jeppesen navigation database. Use this feature on the ground in ground mode as follows:

- 1) With power off, lift USB flash drive door and insert a USB flash drive.
- 2) Power on the system. Rotate **1** to **RUN DEMONSTRATOR/TRAINING PROGRAM** and push to enter.

Use the demonstrator to gain familiarity of the EFIS menu structure and location of button tiles for each operation. Load an instrument procedure prior to take off to view the expected sequence of events.

The demonstrator begins flying over Reno, Nevada, USA at an altitude of approximately 8000' MSL. Altitude may be changed with altitude bug, VNAV profiles or navigation database procedures. Airspeed remains relatively constant but may be controlled with the airspeed IAS bug in the BUGS menu. The simulated aircraft may be positioned anywhere in the world, by activating a flight plan stored in the memory.

All appropriate navigation signals are simulated, allowing for precision and non-precision instrument approaches found within the current navigation database. All obstructions in the latest obstruction database and all

warning, caution, and advisory audible alerts and flag annunciations are presented as appropriate during simulated flights.

NOTE:

When the IDU is operating in demonstrator mode, the IDU is isolated from all sensors and other IDUs. The creation of a flight plan results in that flight plan being stored on that IDU alone. To have that new flight plan available on all other IDUs, the following action must be taken.

- 1) While in flight mode, activate the flight plan created in demonstrator mode.
- 2) With crossfill enabled (in two-sided systems), view active flight plan on any other IDU and press **SAVE (L1)** to save this flight plan on all displays.

2.9. EFIS Training Tool

In addition to the demonstrator program, the EFIS Training Tool (ETT) is available to load on a personal computer. The ETT is compatible with 32- or 64-bit versions of Microsoft Windows®. It serves as a multi-purpose tool for training pilots and provides features to record and capture images and playing back log files. See user guide distributed with the ETT installer for further details.

2.10. Application Software Air Mode and Ground Mode

Numerous symbology elements change behavior depending upon whether the aircraft is on the ground (ground mode) or in flight (air mode). The mode is determined separately from the system initialization modes. This parameter is continuously calculated as follows:

- 1) If a Weight on Wheels/Weight on Ground discrete input is configured, the air or ground modes are determined solely from the discrete input position.
- 2) Otherwise, mode is determined as follows:
 - a) If airspeed is valid and AGL altitude is valid, ground mode is set when indicated airspeed is less than 30 knots, and AGL altitude is less than 75 feet.
 - b) If airspeed is invalid but AGL altitude is valid, ground mode is set when AGL altitude is less than 75 feet.
 - c) Under any other circumstance, air mode is set by default.

Section 3 Display Symbolology

3.1. Introduction

This section details the symbology used on the PFD and MFD in normal and essential modes (where applicable). Not all combinations of possible views are represented.



Figure 3-1: PFD Normal SVS Mode

3.1.1. PFD Display (Basic Mode)

When selected, basic mode is a traditional attitude display with airspeed, altitude, and heading scales appearing in blacked-out areas in a “Basic-T” arrangement but is disabled in unusual attitude mode. The following are no longer present in basic mode:

- | | |
|----------------------------|-------------------------|
| 1) Atmospheric perspective | 5) Flight Path Marker |
| 2) Airspeed Trend | 6) Airport runways |
| 3) Terrain rendering | 7) Highway in the Sky |
| 4) Obstruction rendering | 8) Bank Scale Declutter |



Figure 3-2: PFD in Basic Mode

3.1.2. MFD Display

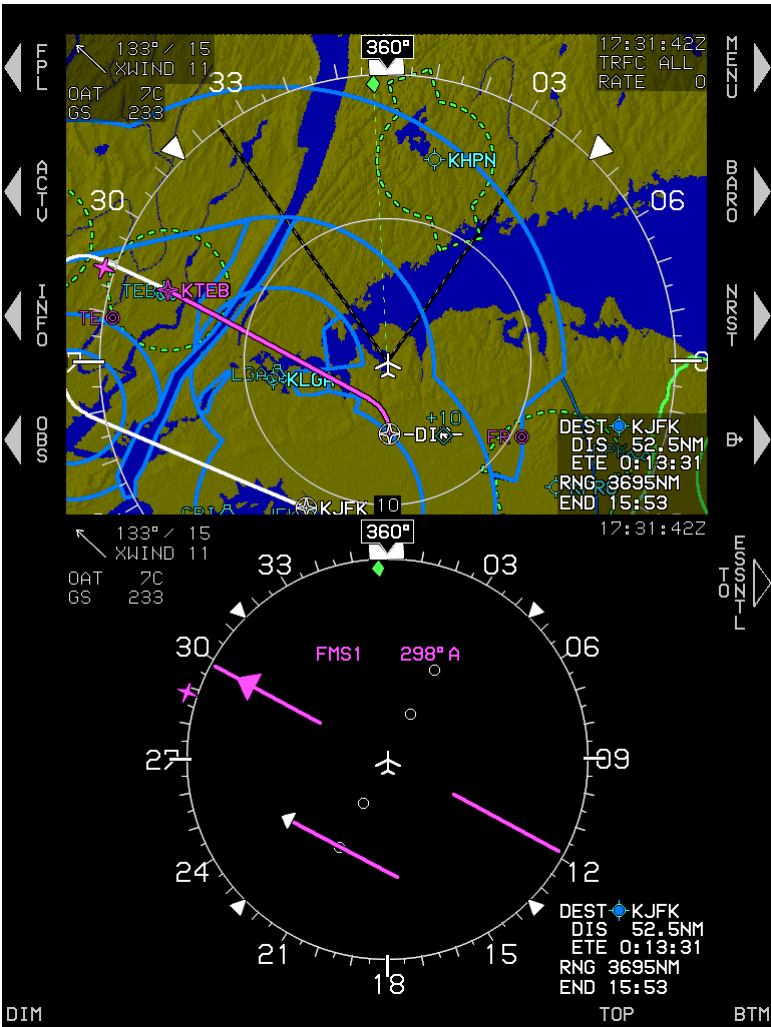

Figure 3-3: MFD in Normal Mode with MAP Page Displayed on Top and HSI on Bottom



Figure 3-4: MFD in Essential Mode

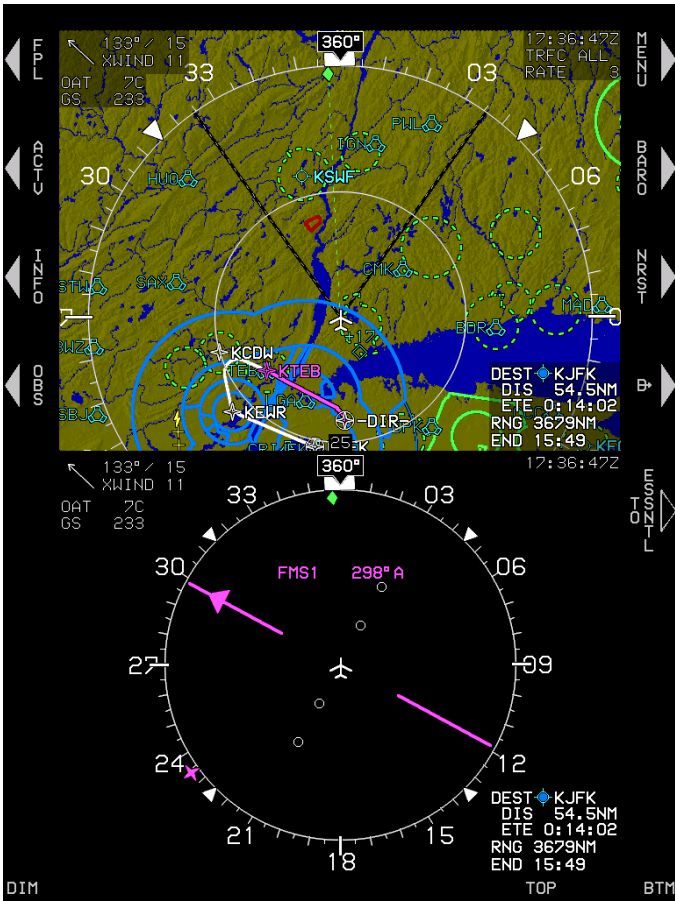

Figure 3-5: MFD in Normal Mode

3.2. Menu Functions



Further menu levels

Without further menu levels

Soft menu function tiles appear in the margins next to IDU buttons and indicate further menu levels with a filled triangle or no further menu levels with a hollow triangle. The triangles point to the associated button.

Figure 3-6: Menu Functions

Menu messages are displayed adjacent to the encoders when appropriate for five seconds. Menu messages are cleared if any IDU button is pressed or encoders 1, 2, or 3 are pushed or rotated.



Figure 3-7: Encoder Functions

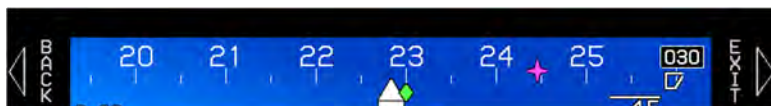

Figure 3-8: Menu Management

When the menu system is beyond the top-level, **EXIT (R1)** escapes to the top-level. When a menu level is deeper than the first level, **BACK (L1)** returns back one level through the menu system.

3.3. PFD Symbology



Figure 3-9: PFD Symbology

The PFD combines pitot-static information, heading, attitude, 3D navigation data, and more overlaid on a virtual background of the outside world. Other objects in the background, including terrain, obstructions, traffic, and runways, are presented conformally as if seen directly in front of the aircraft while looking outside.

3.3.1. Altitude Display

The PFD altitude box with altitude scale on the right side of the display. The altitude box digitally displays barometric altitude as adjusted by an altimeter setting. The digital display of altitude is either purely digital (nearest 10 feet) or rolling digits (nearest 20 feet) as defined in EFIS limits. The altitude box has a pointer that interacts with the altitude scale, which has graduations every 100 feet and labels every 500 feet. The altitude scale background has a gray region and a brown region where the junction between the gray and brown regions indicates ground level. When the ADC sensor fails, a red “X” is displayed in place of the altitude scale.



Figure 3-10: Altitude Display

3.3.1.1. Altitude Display (Metric Units)



Altitude values (altitude display and pilot-selectable target and VNAV altitudes) may be displayed in metric units with a resolution of 1 meter.

Figure 3-11: Altitude Display (Metric Units)

3.3.2. Altimeter Setting



The altimeter setting is immediately below the altitude readout box and digitally displays the altimeter setting in either inches of mercury (inHg) or millibars (mbar) according to the pilot-selected units. Press **BARO (R2)** to enter altimeter setting mode and view the altimeter setting in inHg or mbar value in the lower right corner (Figure 3-13). Rotate **1** CW to increase or CCW to decrease the altimeter setting. Push **1** to enter the new value.

Figure 3-12: Selecting Altimeter Setting



Figure 3-13: Altimeter Setting

QFE: Barometric setting resulting in the altimeter displaying height above a reference elevation (i.e., airport or runway threshold). When in QFE mode on the ground, system automatically sets to read zero altitude. When QFE altimeter setting is selected, “QFE” is annunciated as in Figure 3-12.

QNE: Standard barometric setting (29.92 inHg or 1013 mbar) used to display pressure altitude for flight above the transition altitude.

QNH: Barometric setting resulting in the altimeter displaying altitude above mean sea level at the reporting station. When QNH altimeter setting is selected, no mode is annunciated below the altimeter setting.

3.3.3. Selected Altitude Sub-Mode (Target Altitude)



A target altitude may be set on the autopilot controller. When in selected altitude sub-mode, the altitude scale has a pilot-settable target altitude bug geometrically interacting with the altitude box pointer. The target altitude bug value has a resolution of 100 feet and a range from -1000 feet to 50,000 feet. The target altitude bug setting annunciation includes “ASEL” indicating selected altitude sub-mode.

Figure 3-14: Target Altitude



In altitude hold mode:
Green target altitude bug setting
Filled-white target altitude bug



In climb or descent mode:
White target altitude bug setting
Hollow-white target altitude bug

Figure 3-15: Target Altitude Bug (Vertically Integrated with Autopilot)

When a Genesys/S-TEC DFCS is not installed, the selected altitude is a reference only. The target altitude bug setting is white, and the target altitude bug is filled-white at all times.



With Genesys/S-TEC DFCS



Without Autopilot

Figure 3-16: Target Altitude Bug (With or Without Autopilot)

3.3.4. Altitude Display (VNAV Tile)

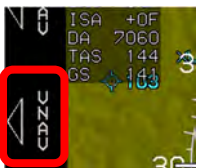

When enabled for performing VNAV with a manually selected altitude entered, **VNAV (L6)** appears.

Figure 3-17: Altitude Display (VNAV Tile)

3.3.5. VNAV Sub-Mode

When in VNAV sub-mode, the altitude scale shows the active waypoint VNAV altitude (if it exists) with a bug symbol geometrically interacting with the altitude box pointer. The VNAV altitude bug setting is annunciated above the altitude scale with a resolution of 100 feet.



When not vertically integrated with a fully integrated digital autopilot, the VNAV altitude bug setting includes “VNAV” indicating VNAV altitude sub-mode.

Figure 3-18: VNAV Sub-Mode (Not Vertically Integrated)

The VNAV altitude bug is a visual reference or, when vertically integrated with an autopilot either fully or partially integrated through the vertical mode discrete input, as a control parameter for climbs or descents.



When a Genesys/S-TEC DFCS is installed, the VNAV altitude provides control inputs to the DFCS and has the following behavior:

When in altitude hold mode, the VNAV altitude bug value is green, and the VNAV altitude bug is a filled-magenta. During altitude hold capture, the VNAV altitude bug-setting flashes.



When in climb or descent mode, the VNAV altitude bug value is white, and the VNAV altitude bug is hollow-magenta.

Figure 3-19: VNAV Sub-Mode with Genesys/S-TEC DFCS

When the VNAV altitude or target altitude differs from aircraft altitude to the extent the associated bug is off-scale, the associated bug appears to be “parked” in the direction of the difference with half of the associated bug visible as seen in Figure 3-19.

3.3.6. Minimum Altitude

A pilot-settable minimum altitude bug consists of a bold yellow line on the altitude scale and a yellow region on the altitude scale from the minimum altitude down to ground level. The minimum altitude bug value is displayed above the altitude scale with a resolution of 10 feet. The minimum altitude bug can be used in conjunction with a selected altitude or VNAV bug. When a minimum altitude is set, descending from above to below causes a voice alert of “Minimums, Minimums” and the minimum altitude to turn amber (yellow) and flash.



Minimum Altitude: 760'

Figure 3-20: Minimum Altitude

3.3.7. Vertical Speed Indicator

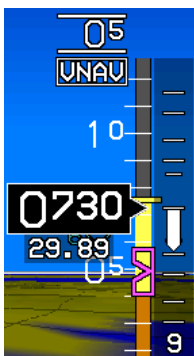

The vertical speed indicator (VSI) is depicted in a "worm" format providing analog and digital representation of VSI in feet per minute (fpm).

Figure 3-21: VSI



The pilot-selectable VSI bug setting (100 fpm resolution) in this example is set to 1000 fpm. The vertical speed bug is used either as a visual reference or, when vertically integrated with an autopilot (either fully integrated or partially integrated through use of the vertical mode discrete input), as a control parameter for climbs or descents. It is mutually exclusive with the airspeed bug.

Figure 3-22: VSI Bug

Table 3-1: Scale Graduations and Display

Traffic Installed	Scale Limit	Scale Graduations and Display
With TCAS-II	±6,000 fpm	±500, ±1,000, ±2,000, ±4,000, and ±6,000 fpm Background of the VSI functions as an RA display with green and red regions to provide RA maneuver guidance.
Without TCAS-II	±3,000 fpm	±500, ±1,000, ±2,000, and ±3,000 fpm



The VSI indication can have a pilot-settable vertical speed bug with a 100 fpm resolution and a range from -3000 to +3000 fpm. It is mutually exclusive with the airspeed bug.

When a Genesys/S-TEC DFCS is not installed, the VSI bug is for reference only. The VSI bug value is white and appears above the VSI indicator. The VSI bug is filled white at all times.

Figure 3-23: VSI Bug without Genesys/S-TEC DFCS



When vertically integrated with a Genesys/S-TEC DFCS, the VSI bug value is green with the speed bug filled-white when in VSI climb or descent mode. Otherwise, the VSI bug value is white and VSI bug is hollow-white.

Figure 3-24: VSI Bug with Genesys/S-TEC DFCS

3.3.8. Normal AGL Indication

AGL altitude is displayed above the course deviation indicator. The source for the indication is the source used by TAWS and displayed next to the AGL altitude as follows:



R = Radar altitude

G = GPS/SBAS geodetic height less database ground elevation

B = Barometric altitude less database ground elevation

Figure 3-25: Normal AGL Indication

AGL altitude is not displayed when it is greater than the radar altimeter maximum valid altitude (2500' AGL or as set in EFIS limits) nor, when it is invalid or when an analog indication is selected by the pilot. Additionally, AGL indication includes the set decision height (see § 3.3.10).

Table 3-2: AGL Indication

Altitude	≥300 Feet	≥100 Feet < 300 Feet	<100 Feet
AGL Indication resolution	10 Feet	5 Feet	1 Foot

3.3.9. Analog AGL Indication



Pilot-selected analog AGL indication is displayed in the lower right corner of the PFD above the active waypoint identifier with a green circular tape and digital readout in the center. The circular tape has a green radial line at its end that disappears above 1000' AGL.

Figure 3-26: Analog AGL Indication

Table 3-3: Analog AGL Indicator

Markings 0-1000 Feet		AGL	Scaling (clock position)
0-100 Feet	100 Feet-1000 Feet	0'	6:00
Linear	Logarithmic	50'	9:00
		100'	12:00
		200'	1:30
		500'	3:00

Table 3-4: Analog AGL Indicator Markings

	Major Tick Marks	Minor Tick Marks
0'	✓	
10'		✓
20'		✓
30'		✓
40'		✓
50'	✓	
60'		✓
70'		✓
80'		✓
90'		✓
100'	✓	
200'		✓
300'		✓
400'		✓
500'	✓	
1000'	✓	

The analog AGL indicator disappears in unusual attitude mode and is mutually exclusive with the mini map, analog G meter, and traffic thumbnail. Analog AGL altitude is not displayed when it is greater than the radar altitude maximum valid value (2,500 feet or as set in EFIS limits), when it is invalid, or when the pilot deselects analog AGL.

3.3.10. Decision Height

Pilot-settable decision height is displayed above the CDI with the abbreviation DH and by a yellow radial on the analog indicator. When the aircraft descends below decision height, **DH ###** turns amber (yellow) and flashes, and the circular tape and readout turn amber (yellow). This is accompanied by “Decision Height” voice alert.

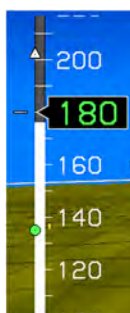

Figure 3-27: Decision Height

3.3.11. Airspeed Display



Rolling Digits



Pure Digital



ADC Failure

Figure 3-28: Airspeed Display

Airspeed is digitally displayed in same color as airspeed scale in knots per hour with interactive pointer. The digital display is either pure digital or incorporates rolling digits as set in EFIS limits. Mach number is displayed above full time with resolution of .01.

The airspeed box pointer interacts with the airspeed scale and has graduations every 10 measurement units with labels every 20 measurement units with high numbers at the top.

The airspeed trend vector calculated along the aircraft longitudinal axis is in a “worm” format to provide analog representation of IAS achieved in ten seconds, assuming the instantaneous longitudinal acceleration rate is maintained along the velocity vector.

The airspeed indication can have a pilot-settable airspeed bug with a 1-knot resolution and a range from $1.2 \times V_s$ (or configured minimum IAS bug speed, if higher) to red-line airspeed (lower of V_{MO} or M_{MO}). It is mutually exclusive with the VSI bug.

Table 3-5: Airspeed Bug Limits

Low end	High end
Higher of $1.2 \times V_s$ or 60KIAS	Red-line (V_{NE} , V_{MO} , or M_{MO})

When a Genesys/S-TEC DFCS is not installed, the airspeed bug is for reference only. The airspeed bug value is white and appears above the airspeed indicator. The airspeed bug is filled white at all times.

When a Genesys/S-TEC DFCS is installed, the airspeed bug value is green and appears above the airspeed indicator. The airspeed bug is filled-white when in airspeed climb or descent mode and provides control inputs to the DFCS. Otherwise, the airspeed bug value is white, and the airspeed bug is hollow white.

The pilot-settable airspeed bug geometrically interacts with the airspeed box pointer and is colored as per Table 3-6.

Table 3-6: Airspeed Bug Setting Annunciation and Bug Colors

	Vertically Integrated Autopilot	
	Without	With
Airspeed Bug Setting	White at all times	Green when in airspeed climb or descent mode otherwise white
Airspeed Bug	Filled-white at all times	Filled-white when in airspeed climb or descent mode otherwise hollow-white



Airspeed trend noodle indicating speed of 211 KIAS within 10 seconds

Figure 3-29: Airspeed Trend



When the airspeed bug value differs from aircraft speed to the extent the bug is off scale, the bug appears to be "parked."

Figure 3-30: Airspeed Bug Off Scale

The airspeed scale background and readout for Part 23 airplanes has coloration as follows:

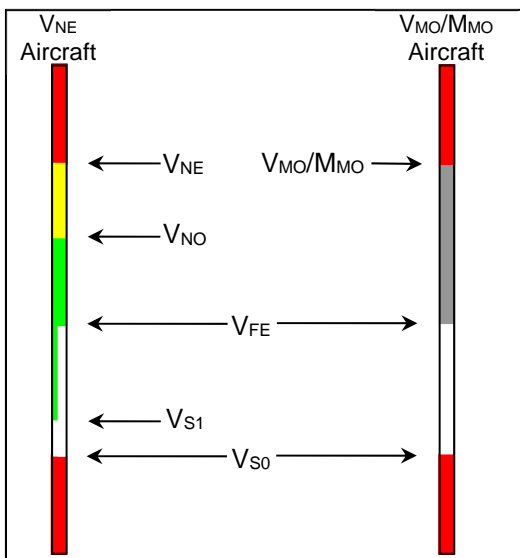

Figure 3-31: Airspeed Scale FAR Part 23

- 1) If in air mode, a red low-speed awareness area from the bottom of the scale to V_{S0} . The airspeed readout is red in this area.
- 2) If in ground mode, a gray area from the bottom of the scale to V_{S0} . The airspeed readout is gray at 0 (indicating “dead” airspeed) but otherwise white in this area.
- 3) If a valid V_{FE} exists, a white flap-operating area from V_{S0} to V_{FE} . The airspeed readout is white in this area.
- 4) For aircraft without a V_{MO}/M_{MO} :
 - a) A green safe-operating area from V_{S1} to V_{NO} . The airspeed readout is green in this area.
 - b) An amber (yellow) caution area from V_{NO} to V_{NE} . The airspeed readout is amber (yellow) in this area.
 - c) A red high-speed awareness area from V_{NE} to the top of the scale. The airspeed readout is red in this area.
- 5) For aircraft with a V_{MO}/M_{MO} :
 - a) A gray safe-operating area from V_{FE} (if it exists) or V_{S0} to V_{MO}/M_{MO} . The airspeed readout is green in this area.

- b) A red high-speed awareness area from the lower of V_{MO} or M_{MO} to the top of the scale. The airspeed readout is red in this area.

The airspeed scale background for Part 25 airplanes (Part 25 “Airspeed Scale Type”) has colored regions and readout coloration as follows:

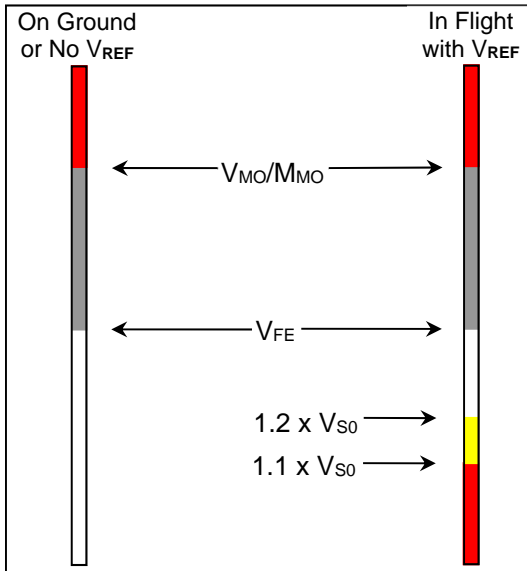

Figure 3-32: Airspeed Scale FAR Part 25

- 1) If in air mode with a pilot-input V_{REF} value:
 - a) A red low-speed awareness area from the bottom of the scale to G-compensated $1.1 \times V_{S0}$. V_{S0} is calculated by dividing the pilot-input V_{REF} by 1.23. The airspeed readout is red in this area.
 - b) An amber (yellow) low-speed awareness area from G-compensated $1.1 \times V_{S0}$ to G-compensated $1.2 \times V_{S0}$. The airspeed readout is amber (yellow) in this area.
 - c) If a valid V_{FE} exists, a white flap-operating area from G-compensated $1.2 \times V_{S0}$ to V_{FE} and a gray normal-operating area from V_{FE} to the lower of V_{MO} or M_{MO} . The airspeed readout is white in the flap-operating area and green in the normal-operating area.
 - d) If a valid V_{FE} does not exist, a gray normal-operating area from G-compensated $1.2 \times V_{S0}$ to the lower of V_{MO} or M_{MO} . The airspeed readout is green in this area.
- 2) If in ground mode or without a pilot-input V_{REF} value:

- a) If a valid V_{FE} exists, a white flap-operating area from the bottom of the scale to V_{FE} and a gray normal-operating area from V_{FE} to the lower of V_{MO} or M_{MO} . The airspeed readout is gray at 0 (indicating “dead” airspeed) otherwise white in the flap-operating area and green in the normal-operating area.
 - b) If a valid V_{FE} does not exist, a gray normal-operating area from the bottom of the scale to the lower of V_{MO} or M_{MO} . The airspeed readout is gray at 0 (indicating “dead” airspeed) otherwise white below 60 and green at or above 60 in this area.
- 3) A red high-speed awareness area from the lower of V_{MO} or M_{MO} to the top of the scale. The airspeed readout is red in this area.

The airspeed scale for Part 25 airplanes has additional specific airspeed markings as follows:

- 1) If pilot-input V_{REF} is valid, white V_S marking at the aircraft's 1-G V_{S0} or an amber (yellow) V_S marking at V_{S0} corrected for G-loading, whichever is higher. V_{S0} is calculated by dividing pilot-input V_{REF} by 1.23
- 2) If enabled (V_{GL} not 0), a “green dot” best glide speed marker at V_{GL} .
- 3) If enabled (V_X not 0), a V_X marking at V_X .
- 4) If enabled (V_Y not 0), a V_Y marking at V_Y .
- 5) If enabled (V_A not 0), a V_A marking at V_A .
- 6) If enabled (V_{MFE} not 0), a “white triangle” maximum flap extension speed marker at V_{MFE} .

3.3.12. Airspeed Display (with EFIS-Coupled)



Airspeed descent to 7,500' with green color and filled airspeed.

Figure 3-33: Airspeed Display (with EFIS-Coupled)

3.3.13. Heading Display

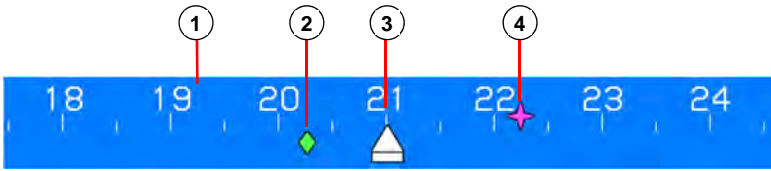

- 1) Heading Scale
- 2) Track Pointer
- 3) Heading Pointer
- 4) Active Waypoint Pointer

Figure 3-34: Heading Display



Figure 3-35: Dampened Integral Slip Indicator

NOTE:

The track pointer is not displayed when indicated airspeed is in the noise range (indicated airspeed or groundspeed is less than 30 knots).

Table 3-7: Heading Display

	<p>Track pointer off scale when aircraft track is displaced from boundaries. (Extreme crosswind conditions)</p>
	<p>When changed, heading bug value displayed for 5 seconds</p>
	<p>When heading bug is displaced beyond boundaries of heading scale, partial heading bug is shown at the limit of the heading scale with the heading bug value above.</p>



When AHRS is in the DG mode, DG appears.

Figure 3-36: DG Indicated when AHRS in DG Mode



Figure 3-37: GPS Loss of Navigation (LON)

3.3.14. Pitch Scale

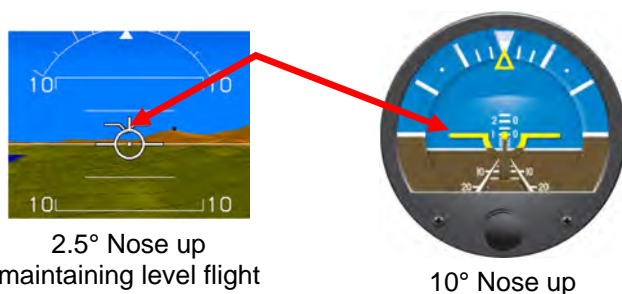

Figure 3-38: Pitch Scale

The PFD has large aircraft symbol reference marks fixed in the center of the display. Rotation of the background, pitch scale, and background oriented display elements occur relative to the location of the large aircraft symbol reference marks.

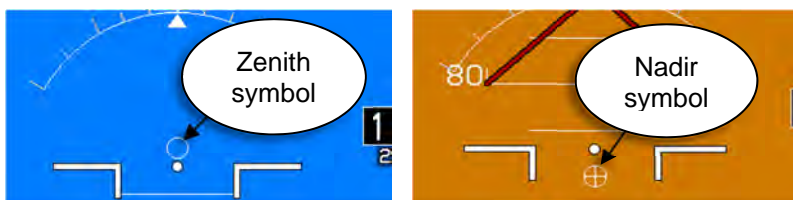

Figure 3-39: Pitch Scale Zenith and Nadir Symbol

Pitch scale has increments every 5° with major increments and pitch scale labels every 10°. Increments are equally spaced to conform approximately

to the 3D PFD background. Pointer bars at the ends of each major increment indicate direction to the horizon and automatically declutter to present the fewest possible increments needed to unambiguously display pitch attitude. The pitch scale terminates with a zenith symbol (small white circle) at +90° and a nadir symbol (small white circle with “+”) at -90°.

3.3.15. Pitch Limit Indicator

The pitch limit indicator first appears above the applicable reference symbol (either the FPM or the large aircraft symbol reference marks) and converges upon the applicable reference symbol as indicated airspeed decreases.

Pitch Limit Indicator Appearance Limits: 1-G V_{S1} or V_{S1} corrected for G-loading.

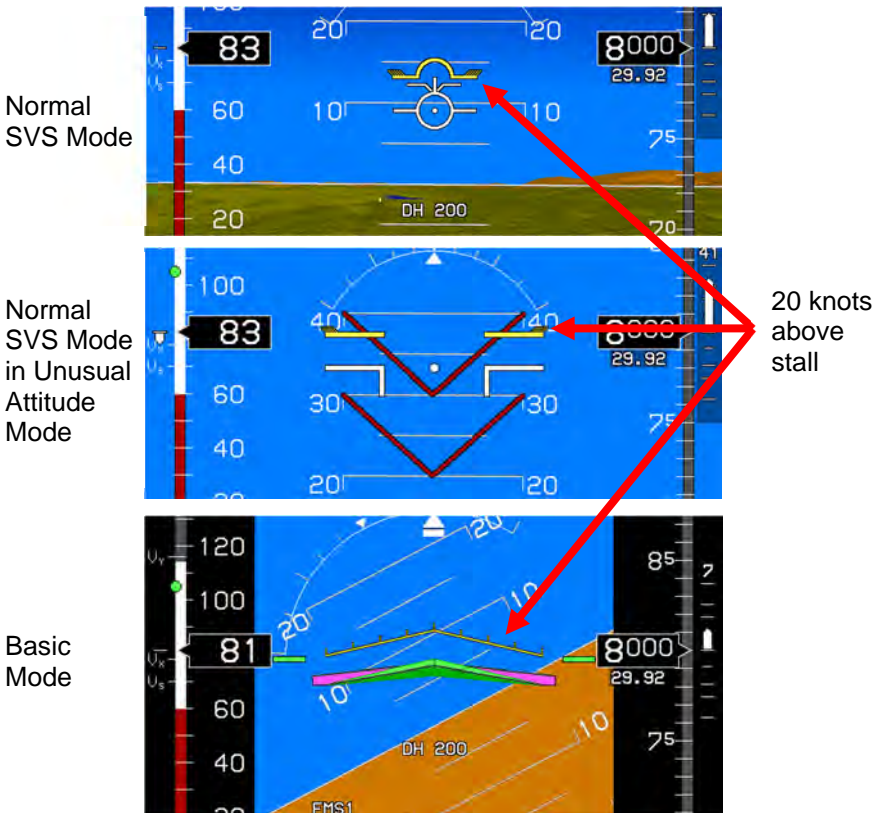

Figure 3-40: Pitch Limit Indicator (20 Knots above Stall)



Figure 3-41: Pitch Limit Indicator (5 Knots above Stall)

3.3.16. Turn Rate Indicator



Figure 3-42: Turn Indication (Selected from Declutter Menu)

3.3.17. G-Force Indicator



G-Force indicator appears in normal mode as depicted or next to the large aircraft symbol reference marks (basic or unusual attitude mode) when difference between G-force and 1-G is greater than 0.3 Gs.

Figure 3-43: G-Force Indicator



Positive telltales appear whenever G-force exceeds 2.5G. Negative telltales appear whenever negative G-force is less than -0.5G. Telltales appear full-time within G-indication area.

Figure 3-44: G-Force Indicator Telltale Indications

When selected from declutter menu, analog G-force indication is displayed to nearest tenth G. The pointer and readout are normally colored white but turn yellow when G-force equals or exceeds a G-limit.

Positive telltale
of 4.2G



Red radial
G-force limits

Figure 3-45: Analog G-Force Indicator



Press **RESET G (L2)** to reset telltales to zero, unless the aircraft G-limits have been exceeded. If G-limits have been exceeded, reset exceedance in GMF.

Figure 3-46: RESET G

3.3.18. Landing Gear Indication

If configured, PFD displays landing gear position as small “tires” below FPM or large aircraft symbol reference marks.

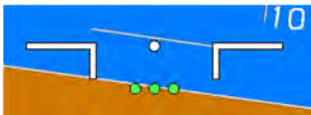

Basic Mode



Normal SVS Mode

Figure 3-47: Landing Gear Indication

3.3.19. Unusual Attitude Mode



Figure 3-48: Unusual Attitude Mode

Unusual attitude mode is enabled when pitch attitude exceeds $+30^\circ$ or -30° or bank angle exceeds 65° . Once enabled, the waterline symbol is replaced by large aircraft symbol and the unusual attitude mode remains engaged until pitch attitude returns to within 5° of the horizon and bank attitude returns to within 10° of the horizon. Recovery chevrons tied to the 30° and higher pitch scale indications (both positive and negative) aid in unusual attitude recovery and are a normal part of the pitch scale and are not necessarily tied to unusual attitude mode.

The following features are disabled in unusual attitude mode:

- | | |
|--------------------------------------|--|
| 1) Terrain and obstruction rendering | 8) Active waypoint symbology |
| 2) CDI | 9) Mini map |
| 3) VDI | 10) Traffic thumbnail |
| 4) Flight path marker | 11) If in basic mode, PFD reverts to normal mode |
| 5) Highway in the Sky boxes | 12) If in zoom mode FOV, PFD reverts to normal FOV |
| 6) Atmospheric perspective | 13) Runways |
| 7) Analog and digital AGL indication | 14) Menus |

3.3.20. PFD Background

The PFD has a 3D background generated from terrain elevation and obstruction elevation data stored in electronic memory. The “actual horizon” displayed on the PFD is based upon the higher of terrain within 90NM or a horizon calculated using a visible horizon equation. Thus, the relative elevation of terrain and obstructions with respect to aircraft altitude and performance is observed by reference to the primary flight information pitch ladder and FPM.

The background has two pilot-selectable field-of-view (FOV) modes, wide FOV mode (approximately 70°) and narrow FOV mode (approximately 35°). In unusual attitude mode, wide FOV mode is automatically selected in the PFI area only.

A blended-tone sky is displayed in conjunction with terrain. The sky fades from light blue at the horizon to dark blue at the top of the display to simulate atmospheric perspective and enhance the 3D presentation. Additionally, the blended sky increases contrast of the directional scale, emphasizes the horizon, and provides a compelling visual cue to a nose-high attitude.



Figure 3-49: PFD Terrain and Obstructions

Terrain and obstruction rendering uses hidden surface removal techniques while terrain/sky rendering uses atmospheric perspective techniques. Terrain with obstruction rendering is collectively pilot-selectable to declutter the display (***independent declutter of obstructions is not possible***). Terrain and obstruction rendering is disabled in the basic mode, unusual attitude mode, and during any reversionary mode. In unusual attitude mode, the blue-brown boundary line of the background decouples from the pitch scale at high pitch angles so a sliver of the blue-brown boundary line always remains visible to give guidance to the horizon.

Terrain ahead of the aircraft is shown conformally with the artificial horizon in the correct scale and perspective for the aircraft's current position and altitude. Worldwide terrain coverage is provided in each IDU and is shown with a resolution as in Table 3-8. Terrain is displayed ahead of the aircraft using a grid and simulates atmospheric perspective (terrain lines fade into the background ground color as they recede into the distance).

NOTE:

There is a one-degree dead band to prevent grid flicker while flying along one of the boundary latitudes. The grid space switching changes at one degree less latitude when flying towards the Equator than it does when flying toward the Poles.

At latitudes greater than 75°, no grid lines are shown. To keep the grid spacing relatively consistent, at latitudes between 45° and 75°, the longitude spacing is increased according as in Table 3-8.

Table 3-8: LAT-LON Resolution Boundaries

Latitude Range	Longitude Grid Spacing	Heading Boundary	
		Pole	Equator
0° to 46°	24 arc-seconds		
46° to 62°	48 arc-seconds	46°	45°
62° to 70°	72 arc-seconds	62°	61°
70° to 74°	96 arc-seconds	70°	69°
74° to 75°	120 arc-seconds	74°	73°

Table 3-9: Terrain and Obstruction Rendering Levels

Feature	Terrain Coloring	Obstructions	Notes
SVS BASIC	Shades of brown for non-water terrain	Within the following ranges, depicted on PFI in SVS Basic or SVS TAWS mode: Narrow FOV: 17NM	Amber and red colors not used for normal display of terrain. Deep blue for areas of water has precedence over shades of brown.
SVS TAWS	Shades of olive when at or below 100 ft. aircraft altitude Shades of brown when above 100 ft. aircraft altitude TAWS coloring of FLTA alert or warning cells	Wide FOV: 12NM	Amber and red colors used for normal display of terrain and terrain areas causing FLTA alerts. Deep blue for areas of water has precedence over other colors.
None	No terrain nor obstructions are shown. Neither, SVS BASIC or SVS TAWS is selected.		

WARNING:

DO NOT USE THIS EFIS FOR TERRAIN-FOLLOWING FLIGHT. DO NOT ATTEMPT TO NAVIGATE USING TERRAIN DEPICTION. ALWAYS ADHERE TO PUBLISHED NAVIGATIONAL INSTRUMENT PROCEDURES AND NAVIGATIONAL CHARTS IN ALL FLIGHT CONDITIONS.

When terrain and obstruction rendering is deselected or disabled, the PFI background is a conventional blue over brown attitude display presentation without atmospheric perspective. Additionally, terrain may be deselected on the PFD and retained on the map display.



Figure 3-50: PFD with Terrain Deselected but Retained on Map

NOTE:

The obstruction data is provided by Jeppesen and must be updated every 28 days to maintain current database information.

Obstructions such as towers, antennas, buildings, and other manmade structures are shown on the PFD display as vertical amber (yellow) lines. Obstructions are conformal in both location and size and are only shown in conjunction with terrain regardless of altitude. Obstructions representing a collision hazard are annunciated audibly and visually with a time-critical warning or caution alert. All vertical amber (yellow) lines in Figure 3-51 are

obstructions near the airport. See Section 2 System Overview for description of alerts when obstructions represent a collision hazard.

WARNING:

MANY TOWERS, ANTENNAS, STRUCTURES, AND OBSTRUCTIONS ARE NOT IN THE DATABASE.



Obstructions without hazardous condition



Obstructions creating an OBSTRUCTION warning

Figure 3-51: PFD with Obstructions

3.3.21. Flight Path Marker (Velocity Vector)

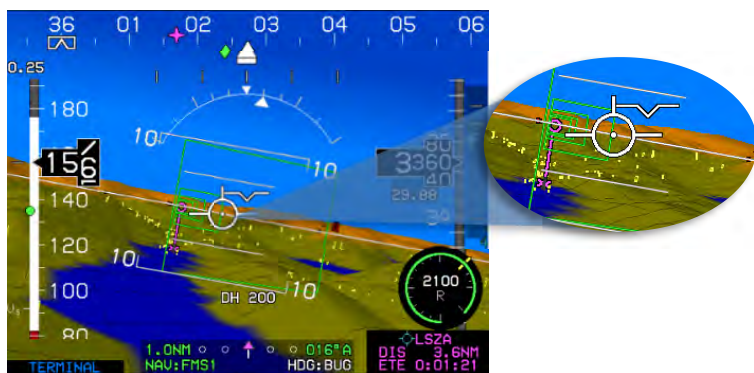

Figure 3-52: Flight Path Marker

The FPM appears on the background to coincide with the aircraft's actual flight path as projected on the outside world. The FPM is laterally displaced parallel to the horizon with respect to the center of the display to account

for the difference between aircraft track and heading, and is vertically displaced perpendicular to the horizon to account for aircraft climb or descent angle.

The FPM is not shown in basic mode. In unusual attitude mode, it disappears to allow the pilot to concentrate on the large aircraft symbol reference marks for unusual attitude recovery. FPM at low speed (airspeed ≤ 45 KIAS) behavior further depends upon whether or not the aircraft is in flight or on the ground and whether or not a WOW/WOG discrete input is enabled.

Because the FPM is used in conjunction with a 3D background, the FPM utility normally associated with a HUD is achieved. When the FPM is displaced to the extent it interferes with heading, altitude, or airspeed indications, it is removed from the display.

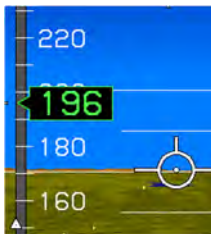

FPM nearing airspeed tape due to strong crosswind.



FPM caged in center due to excessive crosswinds from the right. Ghost FPM appears in proper lateral location.

Figure 3-53: Flight Path Marker Views

When the location of the ghost is displaced to the extent it interferes with heading, altitude, or airspeed indications, the ghost is removed from the display.

Table 3-10: Flight Path Marker Behavior

Table 3-10: Flight Path Marker Behavior	
	Crab Angle
Cage (Become laterally centered on display)	When exceeding 15° (wide FOV) or 7.5° (narrow FOV mode)
Uncage (Resume lateral floating)	When returning below 13° (wide FOV mode) or 6.5° (narrow FOV mode)
FPM movement is dampened by reference to aircraft pitch and heading so as not to deviate from pitch or heading at a rate greater than $1^\circ/\text{sec}$.	

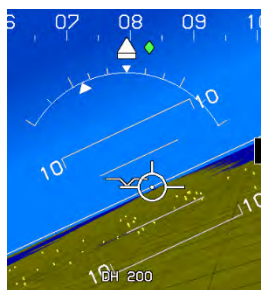

Figure 3-54: Flight Path Marker Ghost



Figure 3-55: Flight Path Marker Absence

3.3.22. Bank Angle Scale



The bank scale and roll pointer are centered upon the large aircraft symbol reference marks in basic or unusual attitude mode. When decluttering is not selected, the bank angle scale and sky pointer appear full time with level, 10°, 20°, 30°, 45°, and 60° marks on left and right sides.

Figure 3-56: Bank Angle

When bank angle scale decluttering is selected, appearance of the bank angle scale and roll pointer are dampened based upon magnitude and time to prevent nuisance appearances, but a bank angle scale and sky pointer are displayed when magnitude of bank angle exceeds 2.8° .

3.3.23. Timer Indication



When selected, a countdown or count-up timer is displayed above the flight path marker or large aircraft symbol reference marks.

Figure 3-57: Timer

3.3.24. Marker Beacon Symbology

Normal
SVS Mode

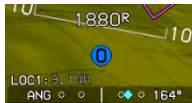

Basic
Mode

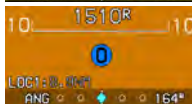

Figure 3-58: Marker Beacons

Marker beacon data acquired from the navigation receiver are displayed on the PFD but are disabled when the selected NAV source is FMS. Valid marker beacon signals cause circular indicators with appropriate coloring and markings.

3.3.25. Flight Director Symbology

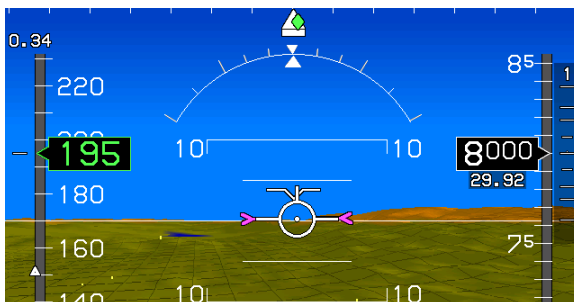

Figure 3-59: Flight Director FD1 Single Cue

Flight director (FD) symbology is controlled on the IDU or integrated autopilot/FD. When selected, FD symbology and valid steering commands are received from the FD with one of the following symbols shown in normal

mode. The PFD has a waterline symbol fixed in the center of the display. Rotation of the background, pitch scale, and background oriented display elements occurs relative to the location of the waterline symbol or large aircraft reference marks.



Figure 3-60: Flight Director FD1 (Basic Mode with Compass Rose Detected on MFD Page)

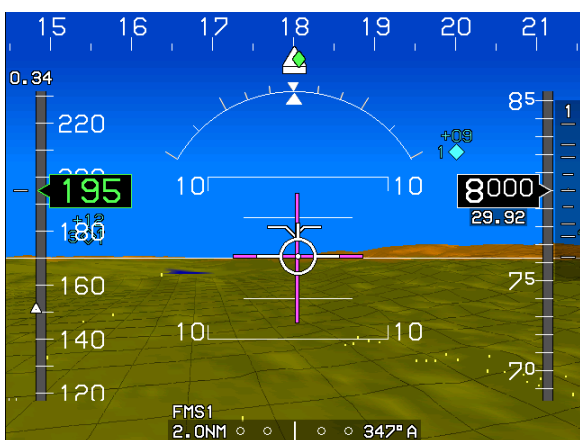

Figure 3-61: Flight Director FD2 (Normal Mode)



Figure 3-62: Flight Director FD2 (Basic Mode without Compass Rose Detected on MFD Page)

3.3.26. Course Deviation Indicator



Figure 3-63: Course Deviation Indicator

The order of precedence of type accuracy used by the system from highest to lowest is as follows:

- 1) Manual RNP: The pilot may override the automatic accuracy types by setting a manual RNP value.
- 2) Automatic RNP: These are based upon RNP values, which are coded in the navigation database. The EFIS looks at the leg coding on all legs other than those on the final approach segment. On the final approach segment, the EFIS looks at the “Level of Service” record for those approaches, which have RNP transition legs, and then goes to LP or LPV minima for the final approach.
- 3) Default TSO-C146C operation: As specified as per Table 3-11 for enroute, terminal, and various approach modes according to the “Level of Service” record.

Table 3-11: CDI Behavior and Color













CDI Pointer and Condition	Color or Behavior
Full Scale Deflection	Flash
Slaved to GPS/SBAS	<p>Scale is appropriate FSD value for mode of flight:</p> <p>Enroute: ± 2 NM</p> <p>From Enroute to Terminal: Change from ± 2 NM FSD to ± 1 NM FSD over distance of 1 NM; start transition when entering terminal mode.</p> <p>From Terminal to Enroute: Change from ± 1 NM FSD to ± 2 NM FSD over distance of 1 NM; start transition when entering enroute mode.</p> <p>From Terminal to Approach: If VTF, switch immediately.</p> <p>Otherwise, change from ± 1 NM FSD to approach FSD over distance of 2 NM; start transition at 2 NM from FAWP.</p> <p>From Approach to Terminal: Change to ± 1 NM.</p> <p>From Departure to Terminal: If initial leg is aligned with runway, change from ± 0.3 NM FSD to ± 1 NM FSD at the turn initiation point of the first fix in the departure procedure.</p>
Slaved to GPS/SBAS (with GPS LON)	Amber (Yellow)
Normal conditions	Magenta
In sources other than FMS	Angular scale annunciation
With Analog Autopilot Configured	
	Reverse sensing (Course error exceeds 105°)
	LNAV in ARM mode**
	Red "X" displayed over CDI
	Holding the wings level*

Table 3-11: CDI Behavior and Color

CDI Pointer and Condition	Color or Behavior
	Selected nav source FMS1**
	Selected nav source VLOC1
	Selected nav source VOR1 with "TO" indication and LNAV captured**
	Selected nav source VOR2 With "FROM" indication
With Genesys/S-TEC DFCS Integrated Autopilot or Without Autopilot Configured (When VOR, LOC, or BC is the NAV source, DME, when available, is displayed next to the NAV source)	
	Reverse sensing (Course error exceeds 105°)
	Red "X" displayed over CDI
	Selected nav source FMS1 (during GPS approach)
	Selected nav source VLOC1
	Selected nav source VOR1 with "TO" indication
	Selected nav source VOR2 with "FROM" indication
*No positive autopilot feedback/**Positive autopilot feedback	

3.3.27. OBS Setting of CDI

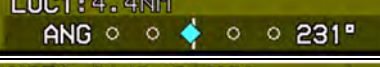
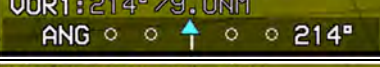
In automatic mode, the system controls the scale and OBS setting according to the requirements of GPS/SBAS (TSO-C-146C). The selected navigation source is annunciated below the CDI as follows:

- 1) NAV: **FMS1/FMS2**
- 2) NAV: **VOR1/LOC1**
- 3) NAV: **BC1/BC2** (annunciated instead of LOC1/2 when course error exceeds 105°)
- 4) NAV: **VOR2/LOC2**

3.3.28. Heading/Roll-Steering Sub-Mode

Heading/roll-steering sub-mode annunciation appears immediately right of the selected navigation source annunciation and displays:

- 1) HDG: **LVL** (wing-leveling sub-mode guidance)
- 2) HDG: **LNAV** (LNAV sub-mode guidance)
- 3) HDG: **BUG** (Heading bug sub-mode guidance)
- 4) HDG: **---** (Failure sub-mode)

3.3.29. No Autopilot or Fully-Integrated Autopilot CDI



Without Autopilot



With Autopilot

Figure 3-64: CDI No Autopilot or Fully-Integrated Autopilot

In an installation without an autopilot or with a fully-integrated autopilot, the heading/roll-steering sub-mode indication is decluttered from the CDI. Therefore, the shaded background of the CDI only falls behind the CDI scale. An abbreviated navigation source indication (without "NAV:") appears above the top left corner of the CDI scale. The heading/roll-steering sub-mode indication does not appear, as it is not required with autopilot mode indications nor when no autopilot is installed.

3.3.30. Vertical Deviation Indicator (VDI)

The vertical deviation indicator (VDI) on the right side displays vertical deviation for the selected vertical navigation source for displaying descent profile but disappears in unusual attitude mode.



Figure 3-65: Vertical Deviation Indicator

- 1) **LPV Mode and LPV1 or LPV2:** When descending on final approach segment in LPV mode. GPS altitude used to generate VDI; pilot may follow guidance to LPV minima regardless of temperature.

- 2) **LNAV Mode and VNV1-G or VNV2-G:** When descending on final approach segment in LP, LNAV/VNAV, and LNAV or RNP modes when using GPS VNAV. GPS altitude used to generate VDI; pilot may follow guidance to LNAV minima regardless of temperature.
- 3) **LNAV Mode and VNV1-B or VNV2-B:** Default FMS barometric VNAV mode. Using barometric altitude to generate the VDI, pilot may follow guidance to LNAV minima as long as the specified temperature is within limits.
- 4) **GS1 or GS2:** Glideslope receiver #1 or #2 as indicated. Pilot follows guidance to published barometric DH.



Figure 3-66: VDI Color during GPS/SBAS LON or VLON

Table 3-12: Vertical Deviation Indicator Behavior

Source (Below VDI)	Behavior/Condition	Pointer Color
FMS	Conforms to the VDI display	Magenta
Glideslope	Source must be valid when a valid glideslope is received.	Magenta
LPV or VNAV mode	Source is valid if: On VNAV descent segments when approaching Top of Descent point to provide descent anticipation as long as the following are true: 1) On VNAV descent segments; or 2) If the vertical deviations on VNAV level segments option is enabled, on VNAV level segments; or	Magenta

Table 3-12: Vertical Deviation Indicator Behavior

Source (Below VDI)	Behavior/Condition	Pointer Color
	<p>3) If the vertical deviations on VNAV level segments option is disabled, when approaching the top of descent point to provide descent anticipation;</p> <p>Providing:</p> <ol style="list-style-type: none"> 1) Aircraft is within 2NM or twice the full scale deflection for the mode of flight (whichever is greater) of the lateral navigation route; and 2) Aircraft is in TO operation relative to the active VNAV waypoint (i.e., taking into account VNAV offsets); and 3) If on the final approach segment, aircraft is within a 35° lateral wedge of the azimuth reference point (either GARP or MAWPT + 10,000 ft.). 	
LPV,VNV-G	During GPS LON or GPS VLON	Pointer and Text Color Amber (Yellow)

3.3.31. Vertical Deviation Indicator (EFIS Coupled)



Figure 3-67: EFIS Coupled Vertically with Glideslope Mode

When vertically integrated with Genesys S/TEC DFCS enabled through glideslope mode discrete input with glideslope mode engaged, the selected vertical navigation source is green indicating the autopilot is vertically coupled. Otherwise, the source is white.

3.3.32. Highway in the Sky/Skyway

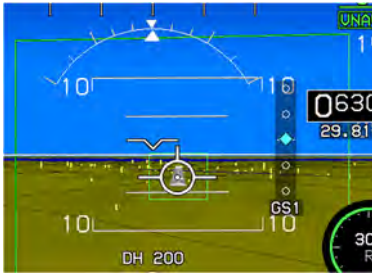

Coupled to Skyway

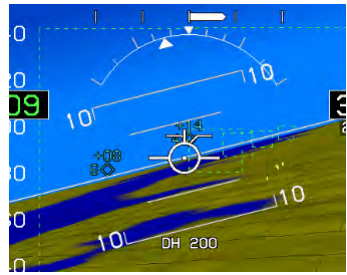

Uncoupled to Skyway

Figure 3-68: Highway in the Sky

When not decluttered, the PFD displays the active navigation route or manual OBS course in 3D with a series of skyway boxes, which overly the flight plan route at a desired altitude and provide lateral and vertical guidance. See Section 7 IFR Procedures for details.

3.3.33. Active Waypoint and Waypoint Identifier

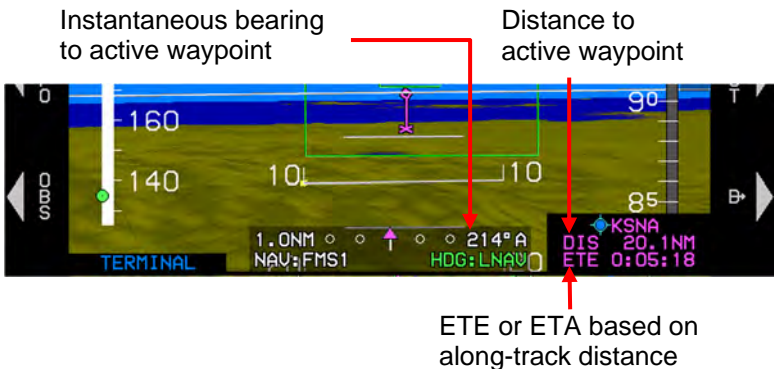

Figure 3-69: Active Waypoint

The PFD displays the active waypoint symbol as a magenta “tethered balloon” consisting of:

- 1) an “X” depicted at the ground location of the active waypoint;

- 2) a hoop or “tethered balloon” (for fly-over waypoints) or “tethered diamond” (for fly-by waypoints) depicted at the VNAV altitude or at aircraft altitude (if there is no VNAV altitude), and
- 3) a line connecting the “X” and the hoop.

The “X” and connecting line are not shown if no ground elevation information is encoded with the NavData® waypoint information (e.g., terminal and enroute fixes). The active waypoint symbol is drawn using the hidden surface removal techniques of terrain and obstruction rendering, so an active waypoint behind terrain appears to be so. The active waypoint symbol disappears in unusual attitude mode but turns amber (yellow) in the event of GPS LON caution.

The identifier of the waypoint along with the distance to the waypoint are displayed in the lower right corner of the PFD in magenta. If a target altitude is not set and the active waypoint has a VNAV altitude associated as in Figure 3-70, the identifier includes a display of the VNAV altitude.

NOTE:

Only the active waypoint is shown on the PFD. Subsequent waypoints in a route are displayed sequentially as the current active waypoint is passed. With terrain turned off, the active waypoint is always visible regardless of distance.

If the active waypoint is beyond the lateral limits of the display, the magenta waypoint direction pointer (i.e., magenta triangle) on the directional scale indicates shortest direction of turn to the waypoint.

If the waypoint is only a hoop hanging in space, it is a fix and not directly associated with a NAVAID on the ground (e.g. VOR, NDB, user waypoint, or airport).



If the waypoint X disappears behind terrain on the PFD, there is terrain between the aircraft present position and the waypoint.

3.3.34. Mini Map



Figure 3-70: Mini Map

Table 3-13: Mini Map Behavior (When Not Decluttered)

Symbology	Color	Condition
VOR 1	 Cyan	When Valid
VOR 2	 Green	When Valid
Active Leg	Magenta	GPS/SBAS normal
	Amber (Yellow)	GPS/SBAS LON
Ownship Symbol (Figure 3-72)	White	
Mutually exclusive with analog AGL, traffic thumbnail, and analog G-Force indicator. Mini Map disappears in unusual attitude mode		



3.3.35. Runways



Figure 3-71: Runways

The EFIS displays airport runways in a 3D manner. Upon activation of a DP, VFR approach, IFR approach, or STAR procedure, runways for the airport associated with the procedure, as well as, runways associated with the three nearest airports (computed by TAWS algorithms) are displayed. Runways are displayed with hidden surface removal techniques of the terrain and obstruction rendering, so runways behind terrain appear to be so. Runways are based on characteristics in the navigation database, including elevation, position, orientation, length, and width, and are displayed as defined in Table 3-14.

Table 3-14: Runway Drawing Criteria

Feature	Color	Notes
Runway markings, aiming point markings, centerline, designation, and displaced threshold arrows	Dark gray 	According to characteristics from navigation database, e.g., including position, orientation, length, and width
Runway markings	Medium gray 	
Landing portion of the selected runway	Light gray 	Taking into account displaced threshold data
Runway markings for the selected runway	Lighter gray than light gray	

3.3.36. Genesys/S-TEC DFCS Autopilot Annunciations

NOTE:

See Genesys/S-TEC DFCS pilot guide and/or AFM for autopilot annunciations and symbology.

3.4. MFD Symbology

The Navigational Display (ND) is presented in a variety of MFD pages:

- | | |
|--|--|
| 1) Moving Map | 5) Traffic (see Traffic appendix) |
| 2) Conventional HSI | 6) Datalink (see Datalink appendix) |
| 3) Navigation Log | 7) Search and Rescue Patterns (see SAR appendix) |
| 4) Strikes (see WX-500 Lightning Strikes appendix) | |

3.4.1. Ownship Symbology

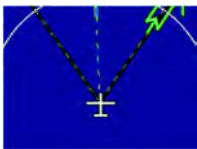

**Airplane
FAR 23 with V_{NE}**

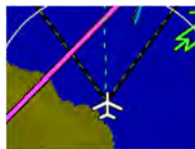

**Airplane
with V_{MO}/M_{MO}**

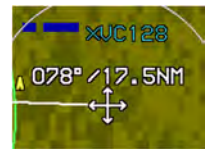

Pan Mode

Figure 3-72: Ownship Symbols

3.4.2. Moving Map



Figure 3-73: Basic Moving Map

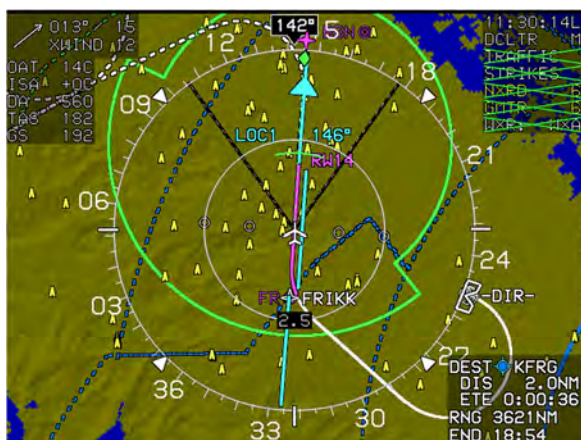

Figure 3-74: Moving Map with Instrument Approach with HSI Enabled



Figure 3-75: North-Up Arc Mode with HSI Enabled and VOR1 Selected



Figure 3-76: North-Up Centered Mode with HSI Enabled and VLOC1 Selected

In heading up mode, the magnetic digital heading readout and pointer are aligned with the longitudinal axis of the ownship symbol.

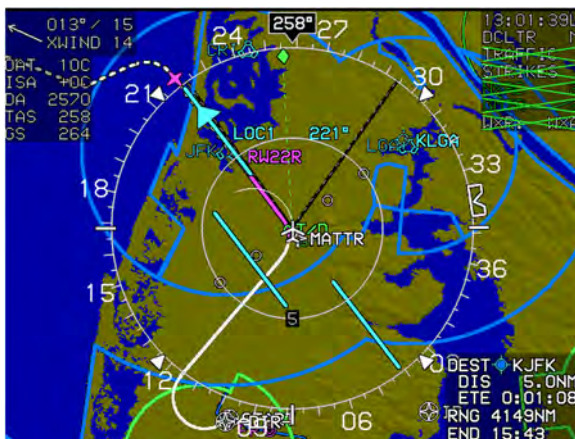

Figure 3-77: Heading-Up Centered Mode

3.4.3. Compass Rose/ND Boundary Circle Symbol



Figure 3-78: Compass Rose/ND Boundary Circle Symbol

3.4.4. Clock/Options

The following are displayed in the upper right corner.

Table 3-15: Clock Options		
Feature	Options	Notes
Zulu Time or Local Offset	hh:mm:ssZ hh:mm:ssL	Synchronized with the GPS/SBAS constellation
Declutter Mode	DCLTR A DCLTR M	= Automatic declutter mode = Manual declutter mode
Terrain Status	Enabled or Disabled	Indicated by the absence or presence of terrain



Zulu Time

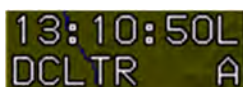

Local Offset Time

Figure 3-79: Clock Options

3.4.5. Air Data and Groundspeed



True North Mode



Normal Mode

Figure 3-80: Air Data and Groundspeed

The following are displayed in the upper left corner:

- 1) **Wind:** Information consists of the following readouts:
 - a) Direction in degrees;
 - b) Speed in knots;
 - c) Crosswind in knots; and
 - d) Graphical wind vector arrow corresponding to MFD page orientation.

NOTE:

Wind information is not shown when the aircraft is in ground mode nor when the AHRS is in DG mode. If referenced to magnetic north, direction readout uses the degree (°) symbol. Otherwise, a stylized true north (T) symbol is used.

- 2) **Density Altitude:** Digitally in feet. Decluttered if the “Show Density altitude if disabled in EFIS limits.
- 3) **Outside Air Temperature:** Digitally in Degrees C or F (as configured).
- 4) **International Standard Atmosphere (ISA):** Difference between ISA temperature and current outside air temperature is displayed digitally in °C or °F (negative value = less than standard OAT). Decluttered if the “Show ISA Temperature” is disabled in EFIS limits.
- 5) **True Airspeed:** Digitally in knots. Decluttered if the “True Airspeed” is disabled in EFIS limits.
- 6) **Groundspeed:** Digitally in knots.

3.4.6. Fuel Totalizer/Waypoint Distance Functions



DEST KRNO
3.8NM
ETE 0:01:19
RNG 1089NM
END 06:15

GPS in normal state and not the current active waypoint



DEST KHWD
DIS 308NM
ETE 1:17:18
RNG 3597NM
END 15:02

GPS in LON condition



DEST KHWD
DIS 309NM
ETE 1:17:22
RNG 3599NM
END 15:02

GPS in normal state and current active waypoint

Figure 3-81: Fuel Totalizer/Waypoint Distance Functions

Table 3-16: Fuel Totalizer/Waypoint Distance Functions

Function	Conditions	Text
DEST Waypoint	If there is an active flight plan, waypoint type, identifier, range, and ETE/ETA for the last waypoint (“DEST” waypoint) are shown. If the active waypoint is not the last waypoint, range and time to destination waypoint are based on the flight plan route. Otherwise, range and time are based on a direct geodetic path.	DEST DIS ETA or ETE

Table 3-16: Fuel Totalizer/Waypoint Distance Functions

Function	Conditions	Text
	Waypoint information is white but turns amber (yellow) with GPS LON caution.	
Range	If fuel flow is available, based on instantaneous fuel flow, fuel remaining and groundspeed are shown immediately below "DEST" waypoint information for easy comparison.	
Endurance	If fuel flow is available, based on instantaneous fuel flow. Fuel remaining is shown.	

3.4.7. Navigation Data

Figure 3-82: Navigation Data and Airspace Depiction

Navigation symbology shown in correct relationship to the ownship symbol and includes the symbols in Table 3-17. The EFIS has manual and automatic decluttering of navigation data. There are six levels of automatic declutter based on the number of potential navigation data symbols drawn in the current format and range as follows:

- 1) **Airports:** Manually or automatically decluttered. In automatic declutter mode, large airports (IFR procedure and longest runway and automatically adjusted threshold needed to achieve desired symbol count) are always shown; IFR airports that are not large airports are shown in levels 1, 2, 3, and 4; and VFR airports are shown in levels 1, 2, and 3.
- 2) **VORs:** Manually or automatically decluttered. In automatic declutter mode, VORs are shown in levels 1, 2, 3, 4, and 5.

- 3) **NDBs:** Manually or automatically decluttered. In automatic declutter mode, NDBs are shown in levels 1 and 2. Both enroute and terminal NDBs are shown.
- 4) **Fixes** (including User Waypoints): Manually or automatically decluttered. In automatic declutter mode, enroute fixes are shown in level 1. Terminal fixes are manually selected and not shown in automatic declutter mode. Enroute fixes, terminal fixes, and user waypoints may be manually decluttered separately from each other.
- 5) **High Altitude Airways:** Manually selected.
- 6) **Low Altitude Airways:** Manually selected.

Table 3-17: Navigation Symbology















	High Altitude Airway		Low Altitude Airway
			
	IFR Airport		NDB
	VFR Airport		Fix
	VORTAC		DME only or TACAN
	VOR		User Waypoint
	User Waypoint in Pan Mode		HSI CDI scale

Table 3-18: Airspace Depiction





Type of ARINC 424 Airspace	Vertical Limits
 Dashed lines	More than $\pm 500'$
 Solid lines	Within 500'
 Thick solid lines	Within airspace vertical limits

Table 3-18: Airspace Depiction

Type of ARINC 424 Airspace	Vertical Limits	Airspace Color
 Class C, control area, TRSAs, Class D		Green
 Class B, TCAs (where applicable)		Blue
 Caution, danger, MOAs, training, warning, or unknown areas		Amber (Yellow)
 Prohibited, restricted, or TFR areas (when equipped with Datalink)		Red

3.4.8. Analog Navigation Symbology

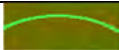
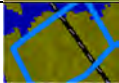

Figure 3-83: Analog Navigation Symbology, HSI in ARC Mode

When selected, the EFIS displays analog (VOR1 [cyan] and VOR2 [green]) navigation symbology when valid. When VOR1 and/or VOR2 RMI pointers are selected for display, bearing and distance for the selected VOR pointers appear at the bottom of the MFD page. Distance readouts match the color of the respective pointer. If the DME channel is in hold mode, “H” is shown above the distance readout. If a bearing or distance are not valid, the respective field is filled with dashes.

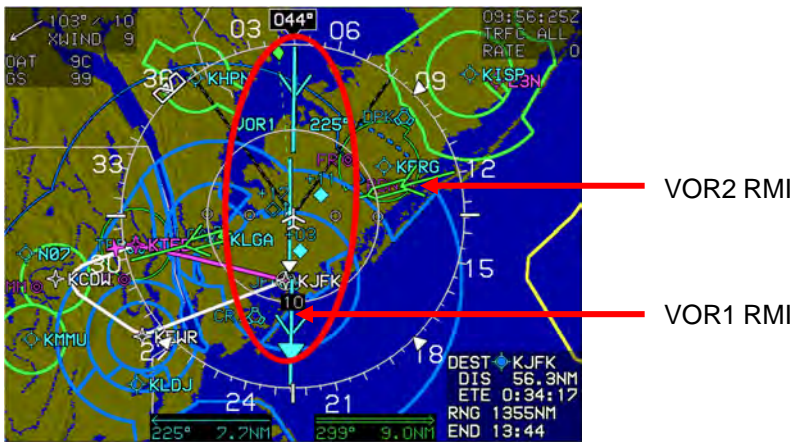

Figure 3-84: Analog Navigation Symbology, HSI in Centered Mode

3.4.9. Borders

National and United States state borders are drawn if selected at all map scales. They are white if the background includes terrain.



Figure 3-85: With International and State Borders



Figure 3-86: Without International and State Borders

3.4.10. Terrain/Obstructions



Figure 3-87: Terrain and Obstructions

Terrain and obstruction rendering is pilot-selectable to declutter the display by deselecting terrain (*independent declutter of obstructions is not possible*). Furthermore, terrain and obstruction rendering is disabled when:

- 1) The GPS/SBAS sensor is failed; OR
- 2) When the ADC is failed; OR
- 3) When the horizontal figure of merit exceeds the greater of 0.3NM or the horizontal alarm limit for the mode of flight.

Terrain is displayed in correct relationship to the ownship symbol using color to show relationship to aircraft altitude.

Table 3-19: Terrain Color

Based on Aircraft Altitude	Color	Notes
Terrain at or below 100 ft. below aircraft altitude	Olive shades	Terrain slope determines shade
Terrain above 100 ft. below aircraft altitude	Brown shades	
FLTA alerts	Amber and Red	See Section 8 TAWS
Water at all altitudes	Deep Blue	Takes precedence over other colors

Table 3-20: Obstructions

Lateral Distance Away	17 NM or less	PFD in Narrow FOV
	12 NM or less	PFD in Wide FOV
	8.5 NM or greater	Not depicted
	8.5 NM or less	As described below
Vertical Criteria	More than 2000' below aircraft	Not depicted
	Within 2000' but more than 500' below aircraft	Depicted in amber
	Within 500' but below aircraft	Depicted in light red
	At or above aircraft altitude	Depicted in deep red

NOTE:

See Section 8 Terrain Awareness Warning System for obstructions causing TAWS alarms and depiction of separate symbology.

3.4.11. Pan Mode



Figure 3-88: Pan Mode

Pan mode is used to view map details along the route of flight and at the intended or alternate destination while in flight or on the ground. When pan mode is active, use labeled buttons to move the pan mode location north, south, east, and west in a north-up, centered orientation. Upon entering the pan mode, the heading pointer, track pointer, lubber line, waypoint pointer, analog navigation symbology, and field of view lines are removed.

Figure 3-88 shows the line with bearing and distance from the map center to the aircraft's current position in white when the aircraft is more than 0.5 NM away. When panning, the nearest displayed airport, VOR, NDB, or fix within the inner range ring is highlighted with a flashing circle. Buttons are labeled for viewing or hiding waypoint information. When exiting pan mode, all settings are restored as before pan mode was enabled.

3.4.12. Start Point



Figure 3-89: Start Point

Activation of **NRST** or **Direct-To** functions creates and activates a flight plan from the present position to the selected waypoint. A waypoint named "START" is placed at the current aircraft location when the flight plan is created.

3.4.13. Direct Point

Unnamed waypoints appear depending upon the procedure loaded when a direct-to command is entered. See Section 7 IFR Procedures for more information.



- 1) **-ALT-** for altitude terminations
- 2) **-DIR-** for waypoints that begin a direct-to leg
- 3) **-DME-** for distance or DME terminations
- 4) **-INT-** for intercept terminations
- 5) **-RAD-** for radial terminations

Figure 3-90: Direct Point

3.4.14. Altitude Capture Predictor/Top-of-Descent

When a selected altitude or VNAV altitude is specified on the PFD, T/D marks correct point on the flight plan path where descent must commence and contains location on the flight plan path with indication of the glidepath angle used to calculate position. After passing top of descent along the lubber line, altitude is captured and shown as a green arc located ahead of the aircraft. The arc marks the bottom-of-descent or top-of-climb point.



Top of Descent



**Top of Climb or
Bottom-of-Descent**

Figure 3-91: Top-of-Descent or Top-of-Climb

3.4.15. Projected Path

When the aircraft is in a bank angle, a projected path emanates from the ownship symbol. This curving path is based on aircraft bank angle and groundspeed as projected one minute into the future up to a maximum of 180° of turn. The projected path or “noodle” assists in course interception and making small adjustments to bank angle for proper roll out.



Figure 3-92: Projected Path

3.4.16. Active Flight Plan Path/Manual Course/Runways

3.4.16.1. Parallel Track

When there is an active flight plan and GPS/SBAS OBS setting is automatic, the flight plan path is shown in correct relationship to the ownship symbol. See Section 5 Menu Functions and Procedures for details on creating a parallel track.



Original flight plan path

Figure 3-93: Parallel Track

3.4.16.2. Manual Course

Manual course through the waypoint shown centered on the waypoint, which matches lateral guidance on PFD (GPS/SBAS CDI in manual mode, skyway boxes, and mini map).

3.4.16.3. Active Flight Plan Path

The active flight plan path's active leg/manual course and active waypoint are magenta but turn amber (yellow) in the event of a GPS LON caution.



Figure 3-94: GPS/SBAS OBS Manual

3.4.17. Field of View Indication

FOV is indicated on the background with a set of segmented gray lines leading out from the ownship symbol in either 35° or 70° angles depending on the zoom mode setting on the PFD.



Normal FOV (Zoom Off)

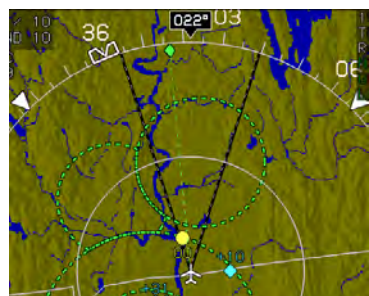

Narrow FOV (Zoom On)

Figure 3-95: Field of View

3.4.18. Range

The white range ring is centered on the aircraft's position to quickly estimate distances. Distance (in NM) from the aircraft to the ring is a white number overlaying the 6 o'clock position of the ring. The range ring is half the distance to the directional scale. Consequently, when the range ring shows a distance of 5NM, the directional scale is 10NM. Rotate **1** or **2** to set the overall map scale ranges to .5, 1, 2.5, 5, 10, 25, 50, 100, and 200NM as appropriate.

When selected, a digital heading readout and pointer aligned with the longitudinal axis of the ownship symbol appears on the compass rose boundary circle. If referenced to magnetic north, the heading readout uses the degree (°) symbol. Otherwise, a stylized true north. See Section 7 IFR Procedures for description of the following heading modes with the AHRS and EFIS:

- 1) ADAHRS Slaved—EFIS Magnetic North
- 2) ADAHRS Slaved—EFIS True North
- 3) ADAHRS Free/"DG"—EFIS Magnetic North
- 4) ADAHRS Free/"DG"—EFIS True North

3.5.2. Clock



Figure 3-99: HSI Clock

Zulu Time or Local Time: As specified in § 3.4.4.

3.5.3. Air Data and Groundspeed



Air data and groundspeed are displayed as shown as specified in § 3.4.5.

Figure 3-100: HSI Display Air Data and Groundspeed

3.5.4. Fuel Totalizer/Waypoint Distance Functions



Fuel totalizer, waypoint and waypoint distance are displayed of the HSI as specified in § 3.4.6.

Figure 3-101: HSI Fuel Totalizer/Waypoint Functions

3.5.5. Conventional HSI/PTR Format

When selected, the EFIS displays conventional HSI symbology, including a selected course needle, lateral deviation indicator, and "TO-FROM" indicator. Navigation source and OBS setting are displayed in the top center of the HSI in the same color as the course needle as follows:

- 1) Magenta (if FMS is the selected navigation source);
- 2) Cyan (if VLOC1 is the selected navigation source);

- 3) Green (if VLOC2 is the selected navigation source); or
- 4) Amber (Yellow) when HSI is slaved to GPS/SBAS and there is a GPS LON condition.



Normal Magenta Pointer

GPS LON Amber (Yellow) Pointer

Figure 3-102: HSI Pointer Color

The ownship symbol (Figure 3-72) is centered and pointing straight up on the HSI. The HSI has a compass rose aligned with either magnetic north or true north depending on the status of the true north discrete input. When the HSI NAV source (FMS, VOR1, or VOR2) fails, a red "X" is displayed in place of the HSI deviations. When the AHRS is in DG mode, "DG" appears to the right of the ownship symbol.

3.5.6. HSI CDI and VDI Scale



Figure 3-103: CDI Scale with VDI

A VDI appears when the VDI source is valid to display vertical deviation information for the currently selected navigation source. When the selected source is FMS, the VDI displayed on the HSI has the same behavior as the

VDI displayed on the PFD, with the exception of the VDI source displayed on the top of the VDI to avoid clutter with waypoint information below.

- 1) VNV1-B: Default FMS barometric VNAV mode
- 2) VNV2-B: Default FMS barometric VNAV mode
- 3) GS1: Glideslope #1
- 4) GS2: Glideslope #2

3.5.7. Analog Navigation Symbolology



Figure 3-104: Analog Navigation Display VOR1 and VOR2

When selected, the HSI displays analog (VOR1 [cyan] and VOR2 [green]) navigation symbolology with an RMI pointer format overlaid upon the HSI. When the signal is invalid, the associated pointer is not shown. When the signal is valid for VOR1 and VOR2, a bearing and distance display for the selected VOR pointers appears at the bottom of the display in the same color of the respective pointer. When an ADF2 is enabled, the ADF2 double needle is as shown in Figure 3-105.



Figure 3-105: Analog Navigation Display FMS and ADF2

If a DME channel is in hold mode, the associated distance readout is displayed in amber (yellow) rather than blue or green, and “H” is above the distance readout.



Figure 3-106: HSI Bearing Distance Readout with DME in HOLD

Valid marker beacon discrettes are displayed on the PFI and HSI page with appropriate coloring markings. Only during a built-in-test may more than one marker beacon be active. Marker beacons are disabled when NAV source is FMS.



- 1) Magenta bearing pointer to active waypoint
- 2) Green ground track pointer
- 3) Final approach course
- 4) Valid marker beacon

Figure 3-107: HSI with Marker Beacon Displayed

3.6. Navigation Log

16:46:23L GS 197		FUEL 133.20AL FLOW 36.30PH				
WAYPOINT	UNAU/OFFSET	PATH	DIST	ETE	ETA	FUEL
◆ KDUT		-DISCONT-	8.4m	0:02	16:42	136
-DIR-		B- 174°	15.3m	0:04	16:47	133
◆ KMSDL		B- 125°	12.3m	0:04	16:51	133
◆ KFFZ		B- 146°	9.3m	0:03	16:54	129
◆ KIWA		B- 182°	50.5m	0:06	17:00	124
◆ KCGZ		B- 301°	40.1m	0:12	17:13	117
◆ KGYR		B- 259°	15.1m	0:04	17:17	114
◆ KBVK		B- 166°	26.3m	0:08	17:25	109
◆ E63		B- 061°	26.0m	0:07	17:33	105
◆ KIWA		B- 051°	27.1m	0:08	17:41	100
◆ KGEU		B- 279°	33.3m	0:10	17:51	93
◆ P48		B- 356°	16.1m	0:04	17:56	91

With Fuel Enabled

05:44:43L GS 103		FLOW 21.80PH				
WAYPOINT	UNAU/OFFSET	PATH	DIST	ETE	ETA	FUEL
◆ KLAX		B- 093°	8.8m	0:05	05:50	
◆ KLOB		B- 117°	5.9m	0:03	05:53	
◆ KTOR		B- 251°	9.0m	0:05	05:58	
◆ KAUX		B- 175°	24.0m	0:14	06:12	
◆ KCRO		B- 091°	59.2m	0:24	06:47	
◆ KRNT		B- 092°	19.1m	0:11	06:58	
◆ L08		B- 054°	32.5m	0:19	07:17	
◆ KPSP		B- 332°	35.3m	0:20	07:37	
◆ KBNG		B- 275°	18.0m	0:10	07:48	
◆ KDNT		B- 268°	38.2m	0:22	08:10	
◆ KLAX		B- 247°	40.7m	0:23	08:34	

Without Fuel Enabled

Figure 3-108: Navigation Log

3.6.1. Clock and Groundspeed

The following are displayed in the upper left corner of the nav log:

- 1) **Zulu Time or LCL Time:** As specified in § 3.4.4.
- 2) **Groundspeed:** Displayed digitally in knots.

3.6.2. Fuel Remaining and Fuel Flow Data

The following are displayed in the upper right corner of the nav log:

- 1) **Fuel Remaining:** If fuel level or fuel flow is available, current fuel remaining is displayed digitally in fuel units.
- 2) **Fuel Flow:** If fuel flow is available, current total fuel flow is displayed digitally in fuel units.

3.6.3. Waypoint Identifier Column

The identifier for each waypoint of the active flight plan is displayed in the left-most column of the nav log. The active waypoint, indicated with an asterisk, is magenta but turns amber (yellow) in the event of a GPS LON caution. Brackets indicate suppressed waypoints. Navigation data symbols are shown with the waypoint identifier to easily distinguish between waypoint types.

When a waypoint is part of a procedure or parallel offset, the following legends are drawn on top of the navigation data symbol:

- 1) **FAF** = Waypoint is a final approach fix.
- 2) **MAP** = Waypoint is a missed approach point.

- 3) **Airway Designation** = Waypoint is part of the designated Airway.
- 4) **MA** = Waypoint is part of the missed approach segment of an instrument approach procedure.
- 5) **APP** = Waypoint is part of an instrument approach procedure but not a final approach fix, missed approach point, nor part of the missed approach segment.
- 6) **VFR** = Waypoint is part of a VFR approach.
- 7) **STAR** = Waypoint is part of a standard terminal arrival procedure.
- 8) **DP** = Waypoint is part of a departure procedure.
- 9) **PTK** = Parallel Offset. In the case of a STAR or DP waypoint subject to a parallel offset, both STAR/DP and PTK are shown.
- 10) **HOLD** = Waypoint is part of an enroute holding pattern
- 11) **SAR** = Waypoint is part of a SAR pattern

3.6.4. VNAV and VNAV Offset Column

VNAV altitude and associated VNAV offset (in NM) are displayed immediately to the right of the waypoint identifier column. In the case of an approach with a final approach segment data block, VNAV offset readout associated with the missed approach point is “GPI” to designate distance to the glidepath intercept point. VNAV altitudes and offsets from the navigation database or manually entered are white; those computed automatically are gray. VNAV and VNAV offset column elements align with waypoint identifier column elements to indicate the VNAV information applies to the associated waypoint.

3.6.5. Path Column

LNAV path between waypoints is displayed immediately to the right of the VNAV and VNAV offset column. The following are displayed:

- 1) Geodetic path between waypoints is displayed with  (R4), followed by the initial geodetic course for the leg.
- 2) Suppressed waypoints (not part of the active flight plan) are shown as dashes.
- 3) Discontinuities (i.e., a leg where FMS is unable to compute a valid path) are shown with the legend “-DISCONT-.”
- 4) Skipped waypoints are shown with the legend “-SKIPPED-.”

- 5) Altitude terminations are shown with leg course followed by the altitude at which the leg terminates.
- 6) Manual legs are shown with leg course followed by “-MAN-.”
- 7) Procedure turns are shown with a pictorial representation of a procedure turn (either left or right turns) as well as the entry and exit course for the procedure turn.
- 8) Holding patterns are shown with a pictorial representation of a holding pattern (either left or right turns) as well as the inbound course for the holding pattern.
- 9) Arc legs are shown with a pictorial representation of an arc (either left or right turns) as well as the entry and exit radials for the arc.
- 10) Radius to a fix legs are shown with a pictorial representation of an arc (either left or right turns) followed by “RF.”
- 11) SAR pattern legs are shown with a pictorial representation of the SAR pattern (Expanding Square, Rising Ladder, Orbit, Race Track, or Sector, each with either left or right turns) followed by “SAR.” (See SAR appendix.)
- 12) Other leg types (Direct, DME termination, radial termination, intercept or course to a fix) are shown using the Direct-To Symbol followed by the leg course.

Path column elements are offset from waypoint identifier column elements to indicate the path information applies to the leg between waypoints.

3.6.6. Distance Column

Distance between waypoints is displayed immediately to the right of the path column and is calculated taking into account the associated path as well as parallel offsets. In the case of a discontinuity, distance between waypoints is the direct geodetic distance between the two waypoints. In the case of suppressed waypoints, skipped waypoints, discontinuities or manual transitions, the distance between waypoints are shown in dashes. Distance column elements are offset from waypoint identifier column elements to indicate distance information applies to the leg between waypoints.

3.6.7. Estimated Time Enroute Column

ETE between waypoints is displayed immediately to the right of the distance column and is calculated taking into account the associated distance between waypoints and current groundspeed. In the case of suppressed waypoints, skipped waypoints, discontinuities or manual

transitions, the distance between waypoints are shown in dashes. ETE column elements are offset from waypoint identifier column elements to indicate ETE information applies to the leg between waypoints.

3.6.8. Estimated Time of Arrival Column

ETA at the active waypoint and all subsequent waypoints are displayed immediately to the right of the ETE column. ETA at the active waypoint is calculated taking into account the associated time remaining on the active leg and current time. ETA at subsequent waypoints is calculated taking into account the cumulative ETEs and current time. In the case of suppressed waypoints, skipped waypoints or manual terminations, the ETA is shown as dashes. ETA column elements align with waypoint identifier column elements to indicate ETA information applies to the associated waypoint.

3.6.9. Fuel Remaining Column

Fuel remaining at the active waypoint and all subsequent waypoints is displayed immediately to the right of the ETA column. Fuel remaining at the active waypoint is calculated taking into account the associated time remaining on the active leg, current fuel flow, and current fuel quantity. Fuel remaining at subsequent waypoints is calculated taking into account the cumulative ETEs, current fuel flow, and current fuel quantity. Fuel remaining column elements are aligned with waypoint identifier column elements to indicate the fuel remaining information applies to the associated waypoint. In the case of suppressed waypoints, skipped waypoints or manual terminations, the fuel remaining is shown in dashes.

NOTE:

Since a suppressed waypoint is not part of the active flight plan, dashes appear in the absence of the following VNAV data associated with a suppressed waypoint:

- 1) Path data
- 2) Distance data
- 3) ETE data
- 4) ETA data
- 5) Fuel remaining data

Section 4 Reversionary Modes

4.1. Reversionary Modes

The equipment has eight reversionary modes as follows:

Mode 0: GPS/SBAS, ADC, and AHRS normal.

Mode 1: GPS/SBAS failed; ADC and AHRS normal.

Mode 2: ADC failed; GPS/SBAS and AHRS normal.

Mode 3: AHRS failed; GPS/SBAS and ADC normal.

Mode 4: GPS/SBAS and ADC failed; and AHRS normal.

Mode 5: GPS/SBAS and AHRS failed; and ADC normal.

Mode 6: ADC and AHRS failed; and GPS/SBAS normal.

Mode 7: GPS, ADC, and AHRS failed.

To use this section, review the following table and notes to determine what feature or function is affected by one or more of the three sensors failed conditions. Examples follow with the IDU-680 displays in various configurations with a table breaking down the affected functions.

Not all possible IDU-680 display configurations and format combinations are represented here. All eight modes of system operation are represented for description purposes.

Table 4-1: PFD Functions

Function	Mode							
	0	1	2	3	4	5	6	7
Airspeed	OK	OK	19	OK	19	OK	19	19
Altimeter	OK	OK	19	OK	19	OK	19	19
Altimeter Set Display	OK	OK	-	OK	-	OK	-	-
Bank Scale	OK	OK	OK	-	OK	-	-	-
CDI	OK	1 + 20	OK	OK	20	20	OK	20
Runway	OK	1	25	-	-	-	-	-
Waypoint Pointer	7	1	7	7	-	-	7	-
Heading Scale	7	7	7	7	7	-	7	-
AGL Ind.	OK	2	4	OK	11	11	4	-
Flight Path Marker	OK	1 + 14	-	-	-	-	-	-
G-meter	OK	OK	OK	-	OK	-	-	-
Ground Track	7	1	7	7	-	-	7	-
Heading Indicator	7	7	7	-	7	-	-	-
Horizon	OK	OK	OK	-	OK	-	-	-
Mini Map	7	1	7	7	-	-	7	-
Pitch Limit Indicator	OK	OK	-	8	-	8	-	-
Pitch Scale	OK	OK	OK	-	OK	-	-	-
Highway in the Sky	OK	1 + 15	-	-	-	-	-	-
Terrain/Obstructions	OK	-	25	-	-	-	-	-
Clock Functions	OK	OK	OK	OK	OK	OK	OK	OK
VSI	OK	OK	-	OK	-	OK	-	-
Waterline Symbol	22	22	5	13	5	13	13	13
Waypoint Symbol	OK	1	-	-	-	-	-	-
Waypoint Brg/Dist	OK	1	OK	OK	-	-	OK	-
Traffic	OK	OK	OK	-	-	-	-	-
Traffic Thumbnail	OK	OK	OK	OK	OK	OK	OK	OK
Speed Trend	OK	OK	-	-	-	-	-	-
Dynamic Stall Speed	OK	OK	-	8	-	8	-	-

Table 4-2: MFD Functions

Function	Mode							
	0	1	2	3	4	5	6	7
Aircraft Position	OK	1	OK	OK	-	-	OK	-
Special Use Airspace	9	1	6	9	-	-	6+ 9	-
Waypoint Pointer	9	1	9	9	-	-	9	-
Active Flight Plan Path	9	1	9	9	-	-	9	-
Glide Range	9	1	-	10	-	-	-	-
Groundspeed	OK	1	OK	OK	-	-	OK	-
Ground Track	9	1	9	9	-	-	9	-
Heading Indicator	9	9	9	-	9	-	-	-
Navigation Symbols	9	1	9	9	-	-	9	-
Outside Air Temp.	OK	OK	-	OK	-	OK	-	-
Projected Path	OK	1	OK	-	-	-	-	-
Traffic	OK	OK	OK	OK	OK	OK	OK	OK
Terrain/Obstructions	OK	-	25	OK	-	-	25+ 9	-
Clock Functions	OK	OK	OK	OK	OK	OK	OK	OK
Waypoint Brg./Dist.	OK	1	OK	OK	-	-	OK	-
Wind	21	3	-	-	-	-	-	-
WX-500 Data	OK	OK	OK	OK	OK	OK	OK	OK
Compass Rose	9	9	9	9	9	-	9	-
Fuel Totalizer Functions	23	24	23	23	12	12	12	12
True Airspeed	OK	OK	-	OK	-	OK	-	-
Density Altitude	OK	OK	-	OK	-	OK	-	-
OAT/ISA Display	OK	OK	-	OK	-	OK	-	-

Table 4-3: Output Functions

Output Functions	Mode							
	0	1	2	3	4	5	6	7
Air/Ground Output	16	16	17	16	17	16	17	17
Autopilot EFIS Valid	16	16	16	-	-	-	-	-
TAWS Alarm Output	16	16	16	16	16	16	16	16
Transmit Enabled	16	16	16	16	16	16	16	16
Warning Light Output	16	16	16	16	16	16	16	16
Caution Light Output	16	16	16	16	16	16	16	16
Mstr. Caut. Light Output	16	16	16	16	16	16	16	16
MDA/DH Output	16	16	18	16	18	16	18	18
Altitude Capture Output	16	16	-	16	-	16	-	-
IAS Switch Output	16	16	-	16	-	16	-	-

- Note 1: Presented using inertial dead-reckoning based on last known wind information. If unable to dead-reckon (e.g., heading is failed or true airspeed cannot be calculated), function is disabled.
- Note 2: Only radar altitude presented when available.
- Note 3: Last known wind is saved during GPS/SBAS failure.
- Note 4: Either radar altitude or geodetic altitude less database elevation.
- Note 5: Waterline symbol expanded to large attitude bars.
- Note 6: Special use airspace boundaries are drawn with bold lines due to lack of aircraft altitude data.
- Note 7: In heading-only failure mode or AHRS failure mode, heading scale aligned with aircraft track and heading indication is removed. In heading-only failure mode or AHRS failure mode combined with GPS failure, heading scale is replaced with a red-X.
- Note 8: Based upon 1G stall speed.
- Note 9: In heading-only failure mode or AHRS failure mode, compass rose aligned with aircraft track and heading indication is removed when in heading up mode. In heading-only failure mode or AHRS failure mode combined with GPS failure, compass rose is removed.
- Note 10: Presenting using last-known wind information and aligned with aircraft track in heading up mode.
- Note 11: Only radar altitude presented when available.
- Note 12: Assuming valid fuel flow information, endurance is presented.
- Note 13: Large attitude bars presented and X'd out.
- Note 14: Flight path marker grayed after one minute to indicate degraded operation.
- Note 15: Highway in the Sky removed after one minute.
- Note 16: See IDU SCC card and limits requirements for activation requirements.
- Note 17: Defaults to AIR unless Weight on Wheel/Weight on Ground discrete input is active.

- Note 18: Only DH function (with valid AGL altitude) in this mode.
- Note 19: Red X in place of scale.
- Note 20: VLOC CDI always available if optional VOR symbology enabled.
- Note 21: Function removed during heading-only failure mode.
- Note 23: Assuming valid fuel flow information, both range and endurance are presented.
- Note 24: Assuming valid fuel flow information, both range and endurance are presented using inertial dead-reckoning based on last known wind information. If the pilot is unable to dead-reckon due to loss of heading or true airspeed cannot be calculated, endurance only information is presented.
- Note 25: Inhibited in accordance with the conditions specified in TAWS automatic inhibit function (abnormal operation).

4.1.1. Oat Sensor Failure Mode

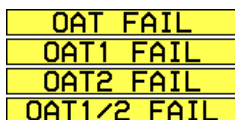

The EFIS has an OAT sensor failure mode. With the OAT sensor failed, wind, OAT, density altitude, and true airspeed are not displayed on MFD pages.

Figure 4-1: OAT Sensor Fail

4.1.2. Heading Failure Mode

The EFIS has a heading failure mode. With heading failed, the PFD heading scale and MFD compass rose align with track (if available) or are removed and replaced with a red-X.



The PFD heading scale includes “GPS TRK” around the track marker to clearly indicate a heading failure mode.

Figure 4-2: GPS TRK

4.1.3. PFD Screen Auto Reversion

For IFR approval in aircraft, flight instrument information essential to safety of flight remains available to the pilot without additional action after a failure. To accommodate this, MFDs have the ability to sense when the PFD has failed and take over the PFD function automatically. Therefore, when an MFD (IDU #2) becomes the transmit-enabled IDU, the MFD automatically switches to essential mode showing PFI in the top area. To change the

MFD back to normal mode after the automatic switch, press **TO MFD/TO ESSNTL (R5)**.

4.1.4. OASIS EICAS Single-Action Reversion

To mitigate the hazards associated with losing the primary display of OASIS EICAS, the pilot may display an OASIS EICAS page on an alternate IDU with a single action. Press **TO NORMAL/TO ESSNTL (R5)** on the PFD or **TO MFD/TO ESSNTL (R5)** on the MFD to alternate between Normal and Essential modes.

NOTE:

This pilot guide does not represent examples with OASIS EICAS, therefore all PFD images are in Normal Mode.

4.1.5. GPS Failure



GPS degrades or fails as a result of loss of satellite information or GPS equipment failure. When SBAS provides the

integrity, the EFIS issues a loss of integrity (LOI) caution within two seconds if the current horizontal protection level (HPL) exceeds the horizontal alert level (HAL). LOI caution appears when there is no integrity monitoring and disappears when it is restored.

Figure 4-3: Loss of Integrity (LOI)

Further GPS degradation causes the EFIS to lose GPS updating of aircraft position, groundspeed, and ground track, and the ability to calculate the wind information.

- 1) **LOI** (Loss of Integrity) displayed with no time delay.
- 2) HPL > HAL for the phase of flight currently in. Position is still presented based upon a GPS navigation solution.

- 3)  (Loss of Navigation) displayed with no time delay of the onset of the following:

- a) The absence of power;
- b) Equipment malfunction or failure;

- c) The presence of a condition lasting five seconds or more where there are an inadequate number of satellites to compute position solution;
- d) Fault detects a position failure that cannot be excluded within time-to-alert when integrity is provided by FDE;
- e) $HPL > HAL$ on the final approach segment. Genesys Aerosystems EFIS does not transition to DR navigation at this stage. A GPS navigation solution is still presented; and
- f) Where $HPL > HAL$ on the final approach segment, this position may still be satisfactory for GPS navigation. For example, an HPL of 0.31NM exists, which means as soon as a transition to terminal mode occurs, all alerts disappear. This is significantly important during a wind change if the system had been in a DR mode.

NOTE:

At any time, view HFOM on the faults page to see the system-reported accuracy.



Figure 4-4: FAULTS Page on MFD

4) DR (Dead Reckoning)

DR 00:00
DR 01:23 If a GPS position cannot be calculated, a dead reckoning solution is provided with a timer. This solution is calculated from heading and TAS derived from the AHRS and ADC.

Figure 4-5: Dead Reckoning

5) Loss of Vertical Navigation (VLON)



Figure 4-6: Loss of Vertical Navigation (VLON)

If the navigation equipment is no longer adequate to conduct or continue the LNAV/VNAV approach, “VLON” appears within one second of the onset of any of the following conditions:

- a) The absence of power;
- b) Equipment malfunction or failure;
- c) The presence of a condition where fault detection detects a position failure that cannot be excluded;
- d) There are an insufficient number of SBAS HEALTHY satellites;
- e) The horizontal protection level exceeds the alert limit as follows for LNAV/VNAV approaches:
 - i) Prior to sequencing, the FAWP- HAL should be 0.3 NM with no limit on VAL.
 - ii) After sequencing the FAWP- HAL 556m (0.3NM) and VAL 50m.

When in LNAV mode, the fault detection function detects positioning failures within 10 seconds after the onset of the positioning failure.

4.2. PFD and MFD Failure Mode Examples

GPS failure results in the EFIS operating in dead reckoning mode. The EFIS continues to provide navigational position, groundspeed, and ground track information, based upon the last known wind, current air data, and heading. The PFD and MFD are affected as follows.

4.3. PFD Failure Mode 0



Figure 4-7: PFD Failure Mode 0
GPS, ADC and AHRS Normal

4.3.1. MFD Failure Mode 0 (Normal Mode)

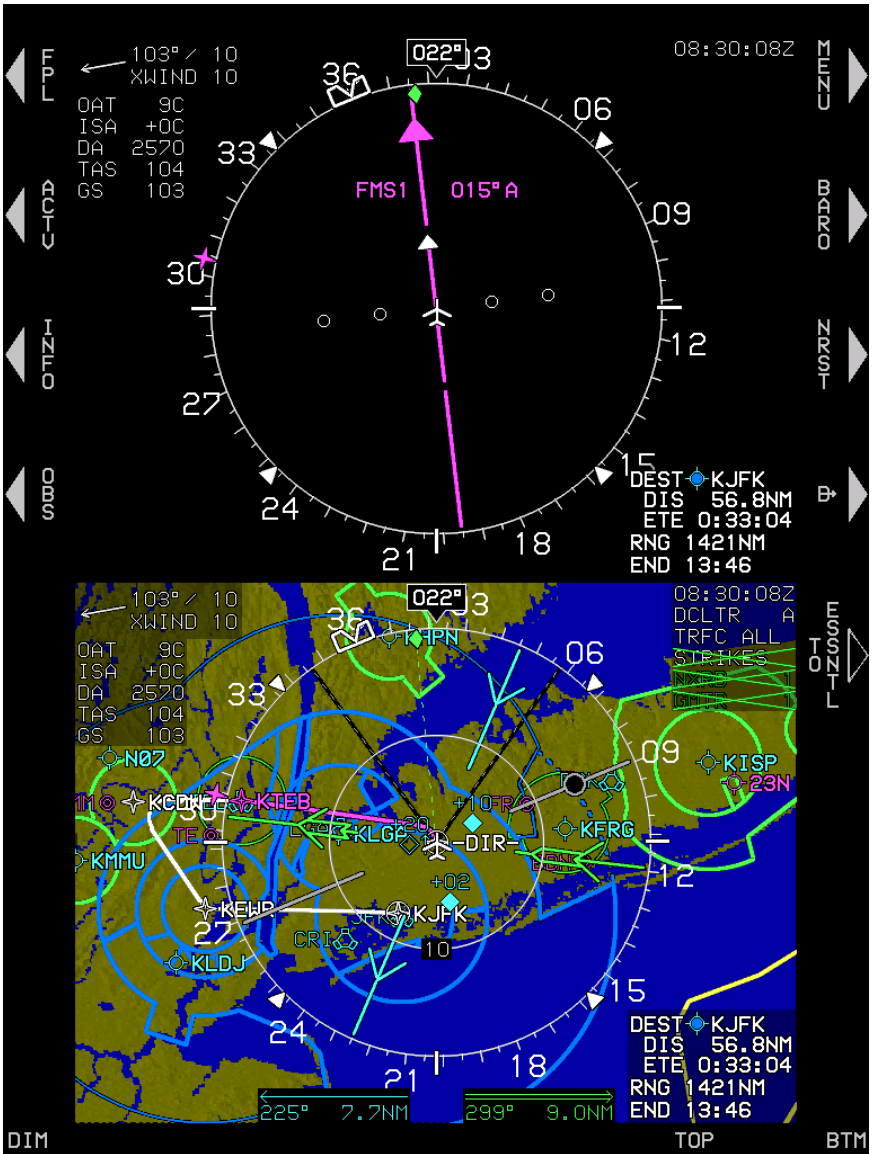

**Figure 4-8: MFD Failure Mode 0 (Normal Mode)
GPS, ADC and AHRS Normal**

4.4. PFD Failure Mode 1

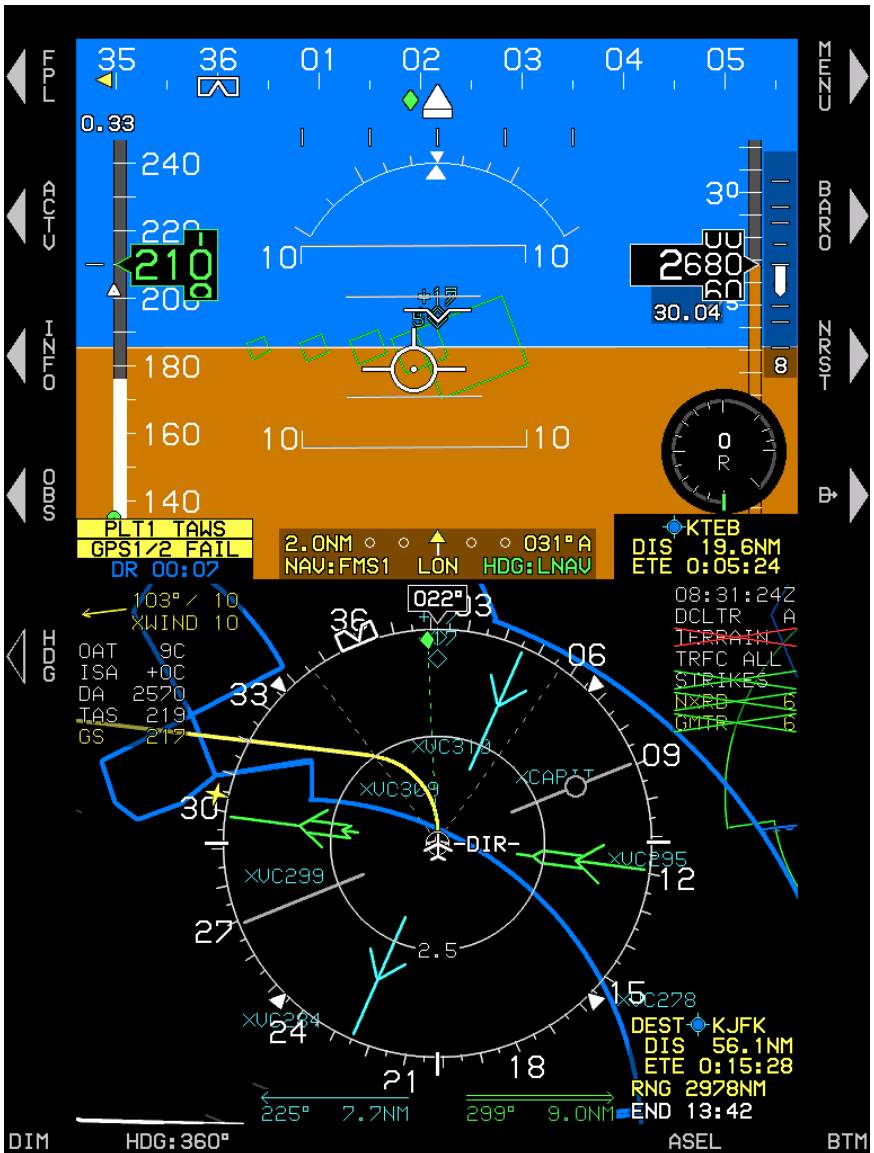
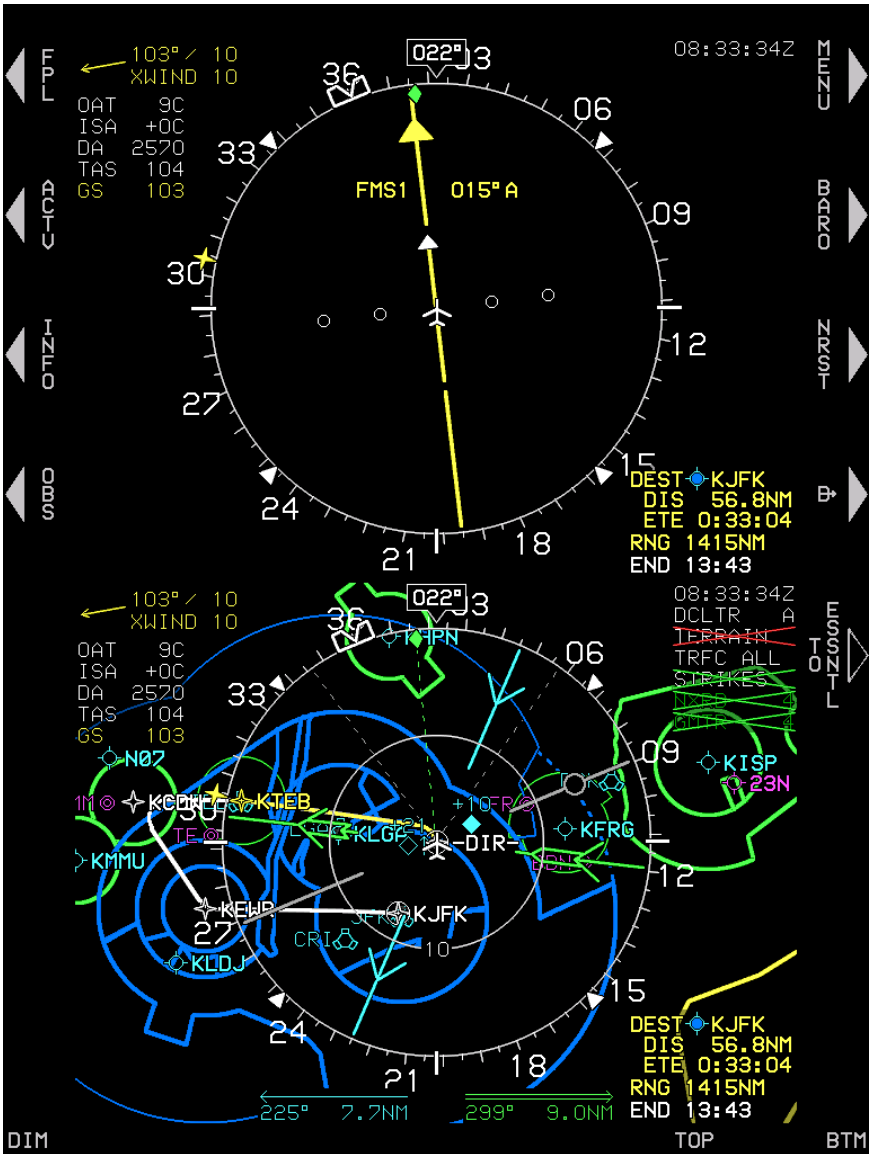

Figure 4-9: PFD Failure Mode 1
GPS/SBAS Failed, ADC and AHRS Normal

4.4.1. MFD Failure Mode 1 (Normal Mode)



**Figure 4-10: MFD Failure Mode 1 (Normal Mode)
GPS/SBAS Failed, ADC and AHRS Normal**

4.5. PFD Failure Mode 2



Figure 4-11: PFD Mode 2
ADC Failed, GPS/SBAS and AHRS Normal

4.5.1. MFD Failure Mode 2 (Normal Mode)

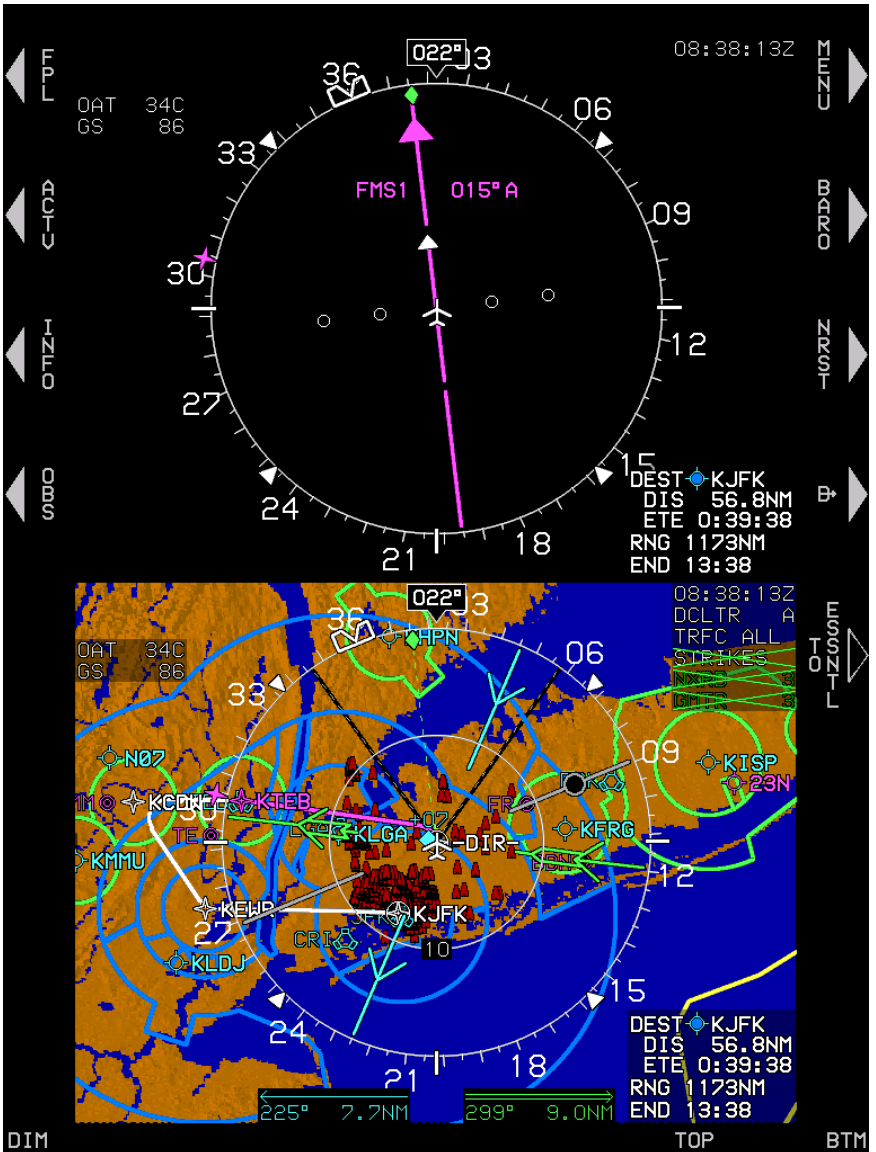

**Figure 4-12: MFD Failure Mode 2 (Normal Mode)
ADC Failed, GPS/SBAS and AHRS Normal**

4.5.2. MFD Failure Mode 2 (Essential Mode)

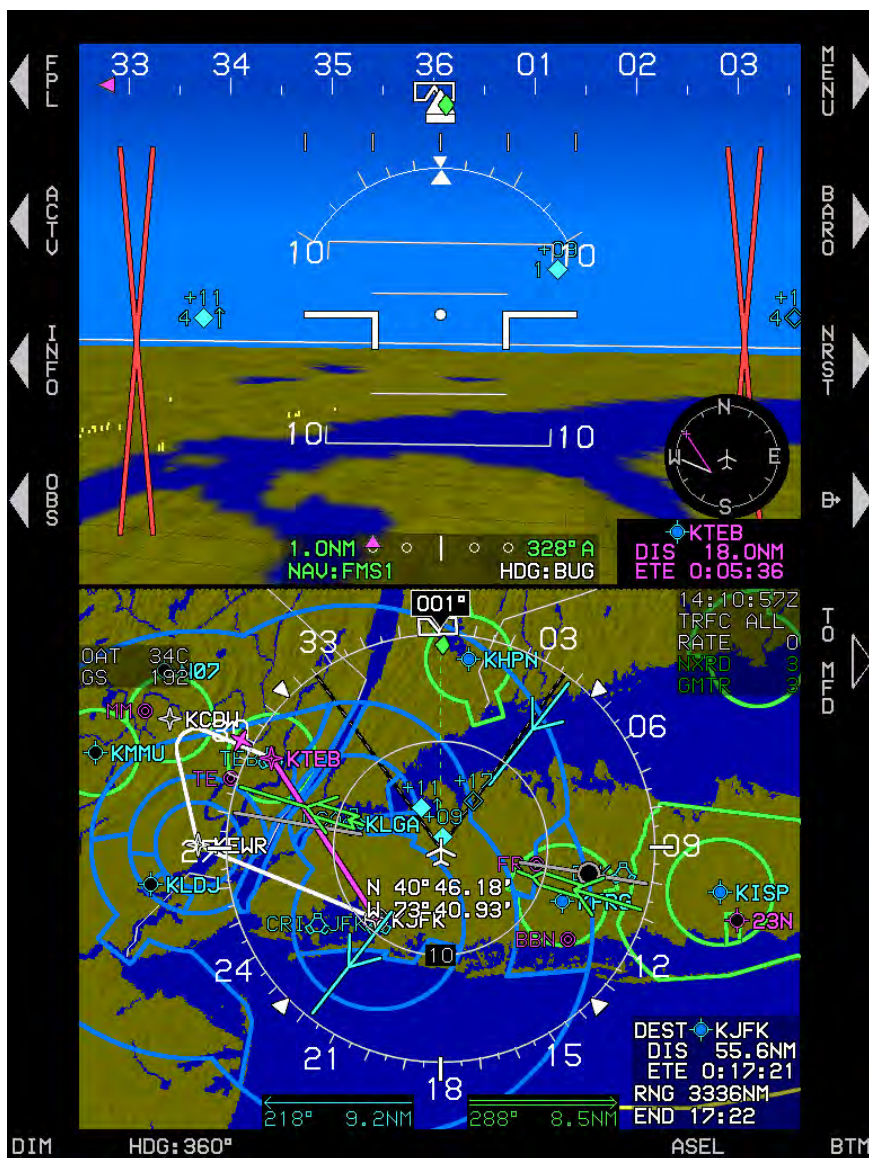

**Figure 4-13: MFD Failure Mode 2 (Essential Mode)
ADC Failed, GPS/SBAS and AHRS Normal**

4.6. PFD Failure Mode 3



**Figure 4-14: PFD Failure Mode 3
AHRS Failed, GPS/SBAS and ADC Normal**

4.6.1. MFD Failure Mode 3 (Normal Mode)

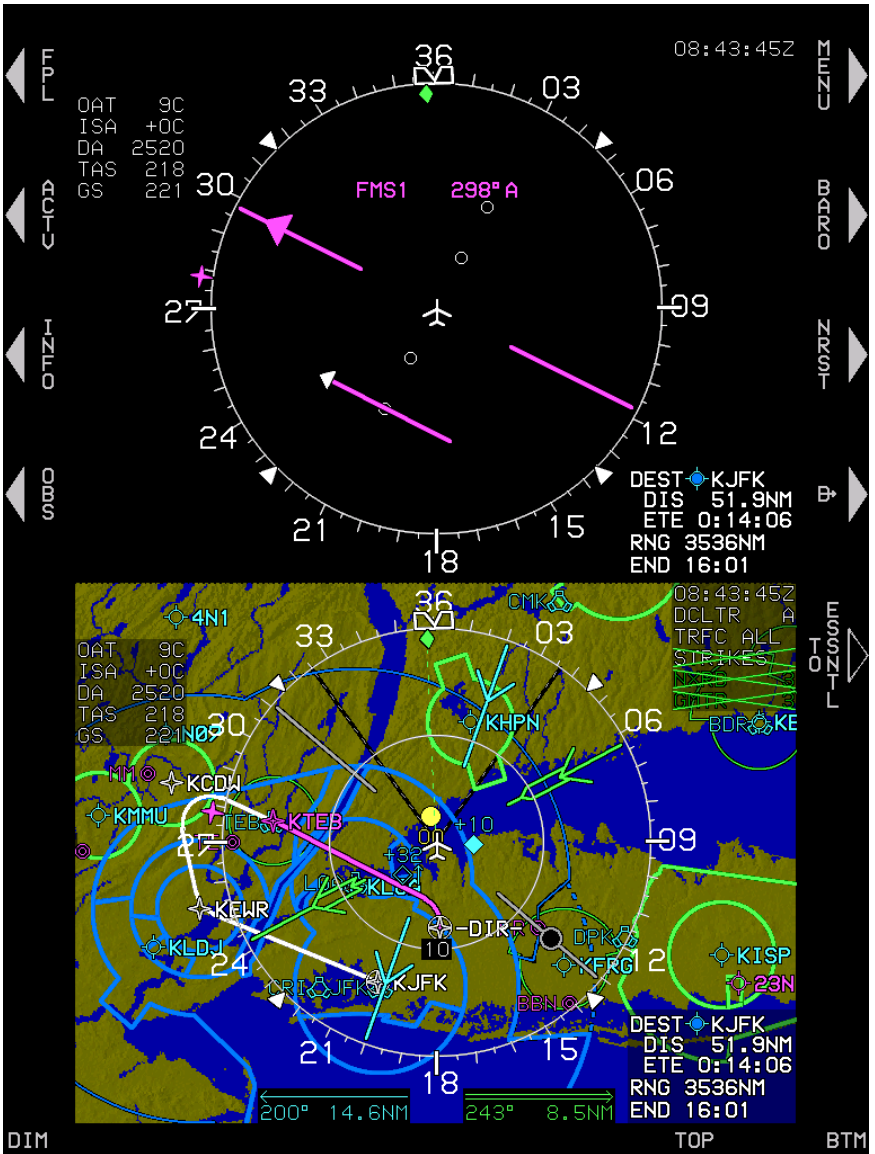

**Figure 4-15: MFD Failure Mode 3 (Normal Mode)
AHRS Failed, GPS/SBAS and ADC Normal**

4.7. PFD Failure Mode 4

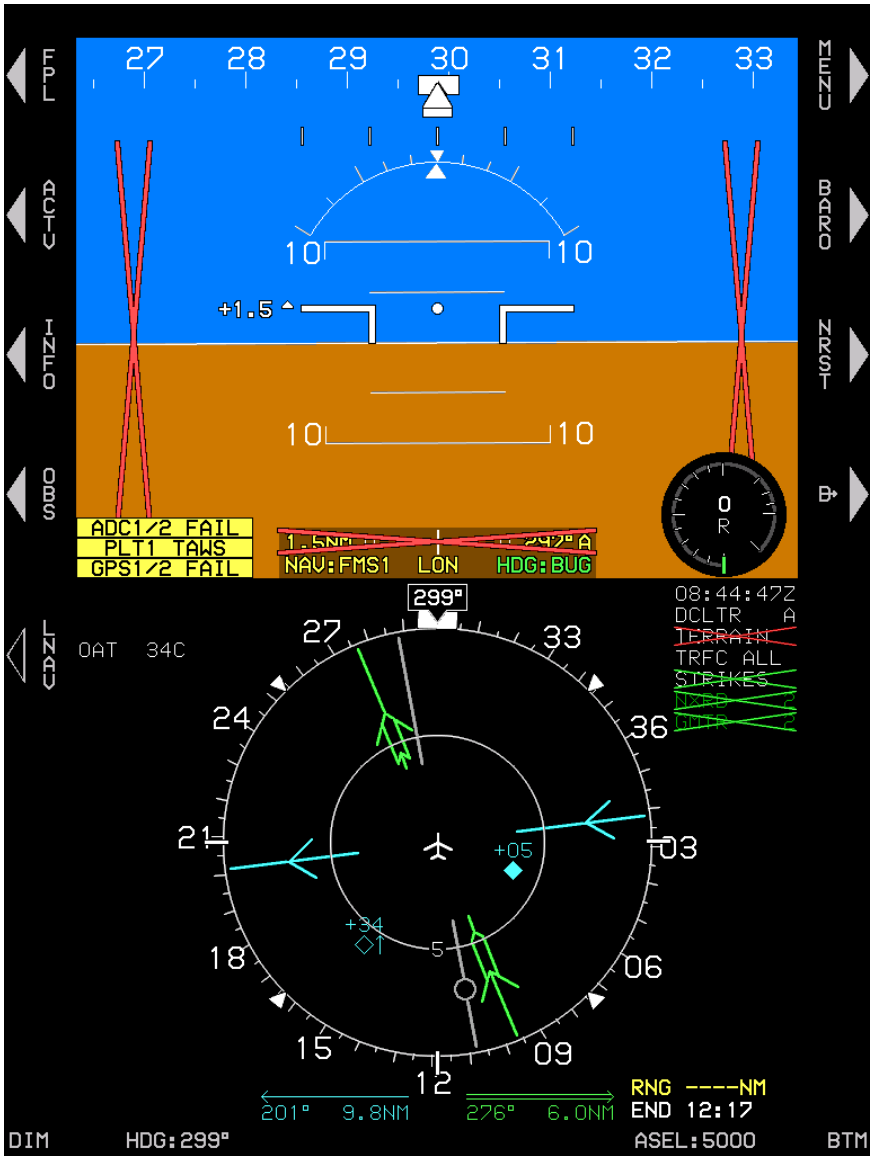

**Figure 4-16: PFD Failure Mode 4
GPS/SBAS and ADC Failed, AHRS Normal**

4.7.1. MFD Failure Mode 4 (Normal Mode)

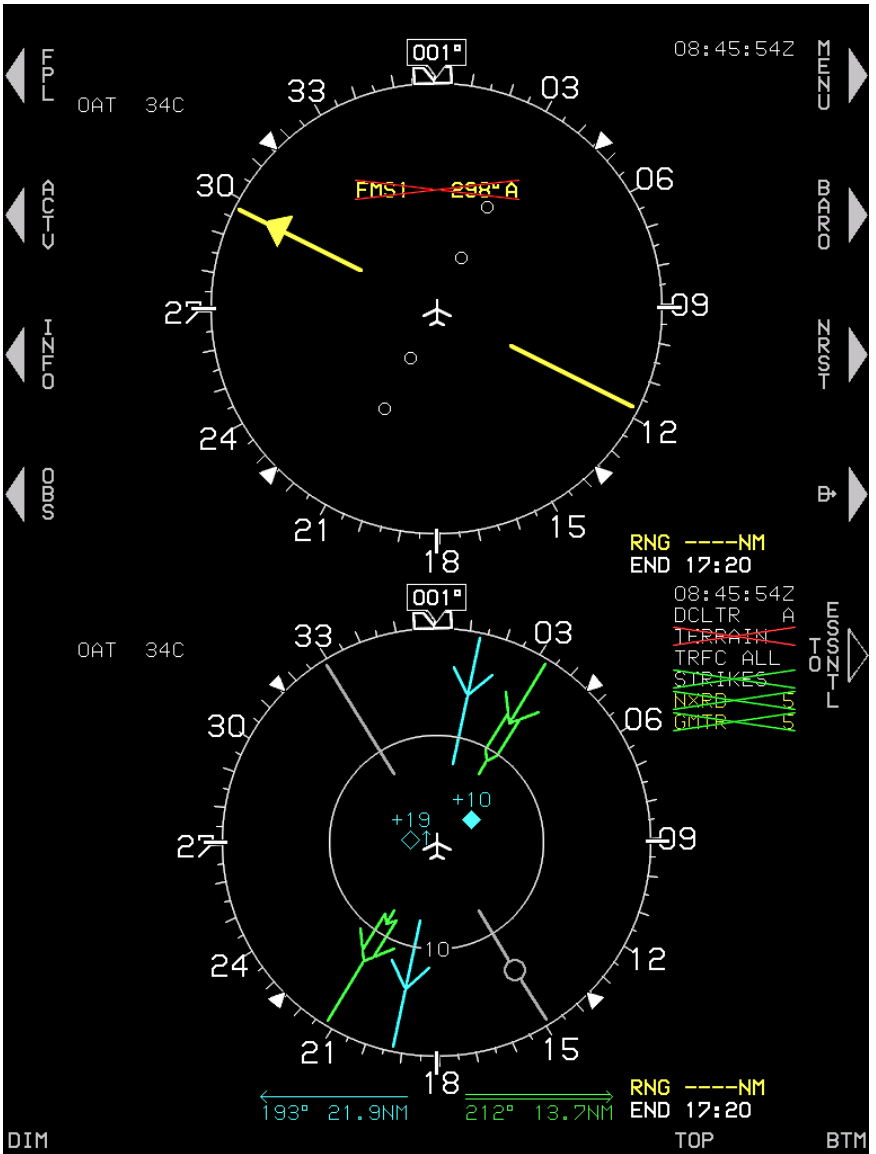

**Figure 4-17: MFD Failure Mode 4 (Normal Mode)
GPS/SBAS and ADC Failed, AHRS Normal**

4.7.2. MFD Failure Mode 4 (Essential Mode)

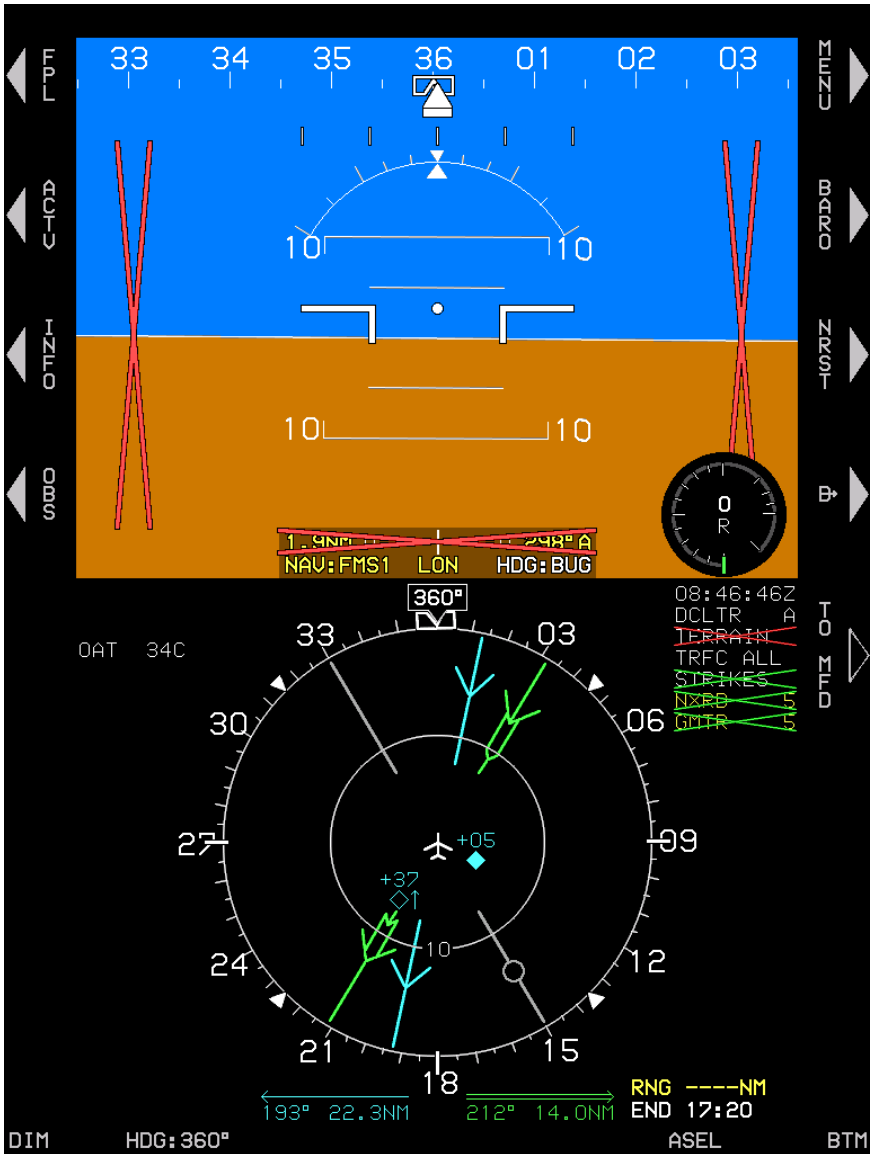

**Figure 4-18: MFD Failure Mode 4 (Essential Mode)
GPS/SBAS and ADC Failed, AHRS Normal**

4.8. PFD Failure Mode 5

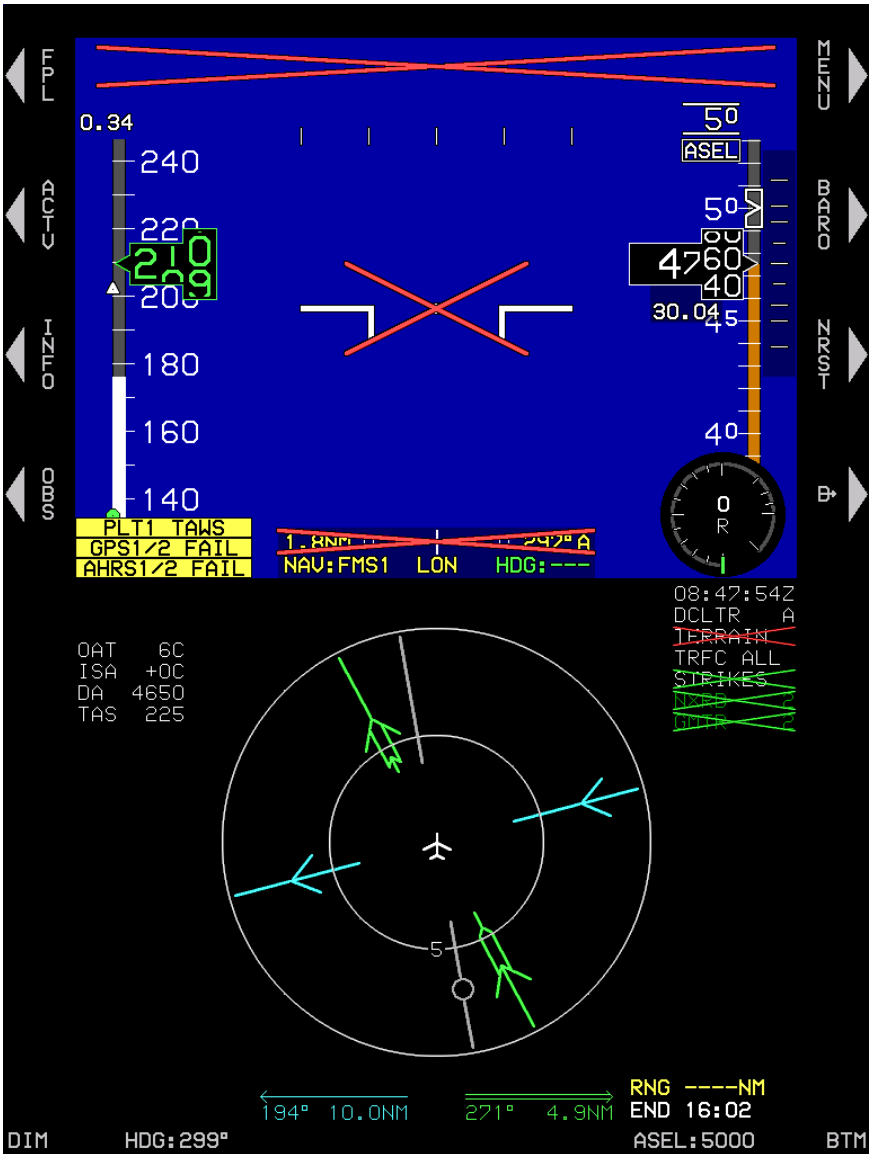

**Figure 4-19: PFD Failure Mode 5
GPS/SBAS and AHRS Failed, ADC Normal**

4.8.1. MFD Failure Mode 5 (Normal Mode)

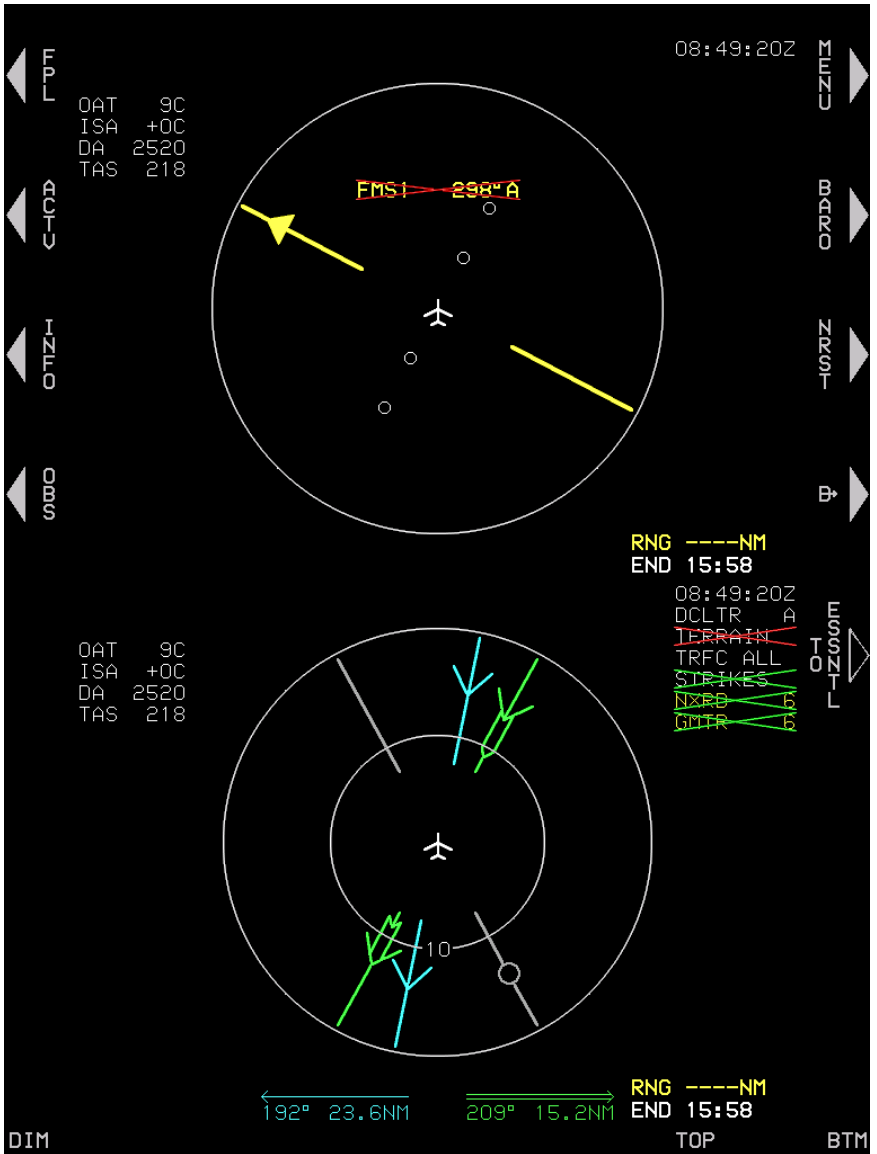

**Figure 4-20: MFD Failure Mode 5 (Normal Mode)
GPS/SBAS and AHRs Failed, ADC Normal**

4.8.2. MFD Failure Mode 5 (Essential Mode)

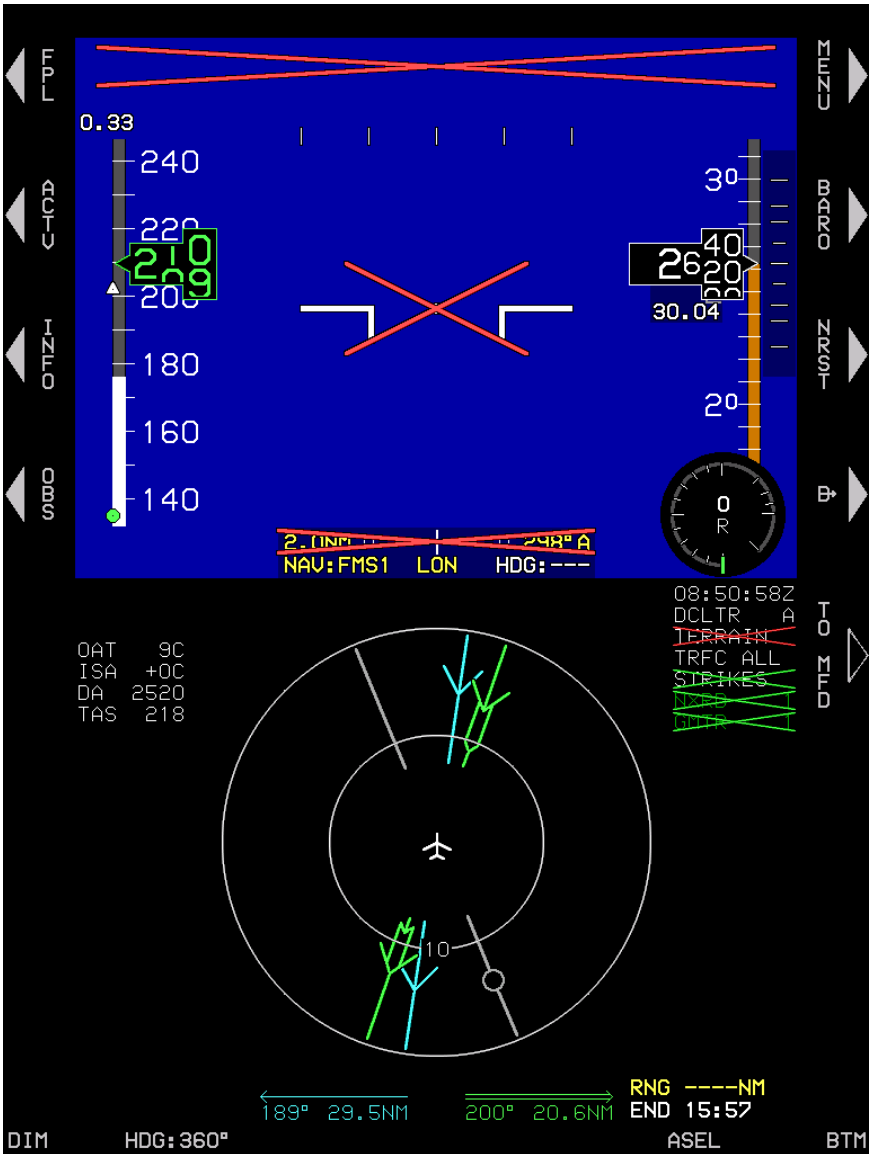

**Figure 4-21: MFD Failure Mode 5 (Essential Mode)
GPS/SBAS and AHRs Failed, ADC Normal**

4.9. PFD Failure Mode 6

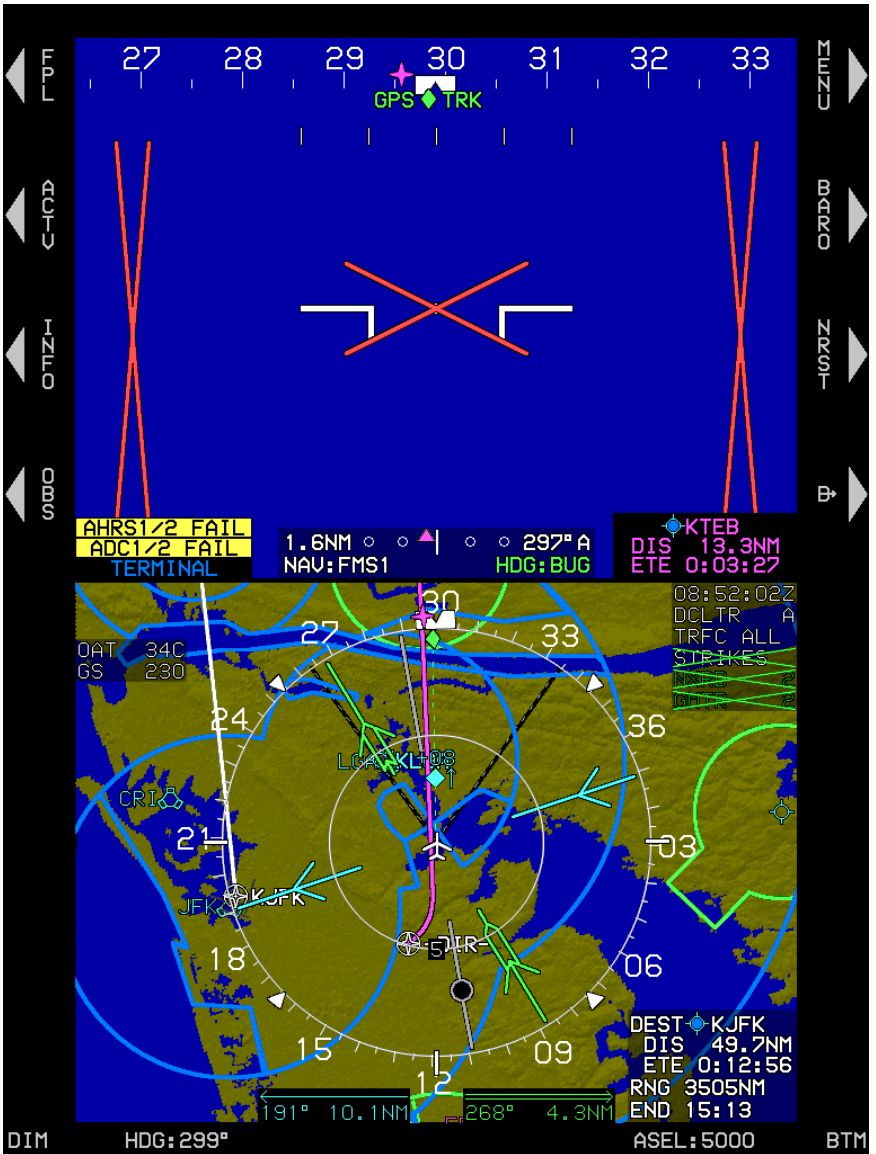

**Figure 4-22: PFD Failure Mode 6
ADC and AHRS Failed, GPS/SBAS Normal**

4.9.1. MFD Failure Mode 6 (Normal Mode)

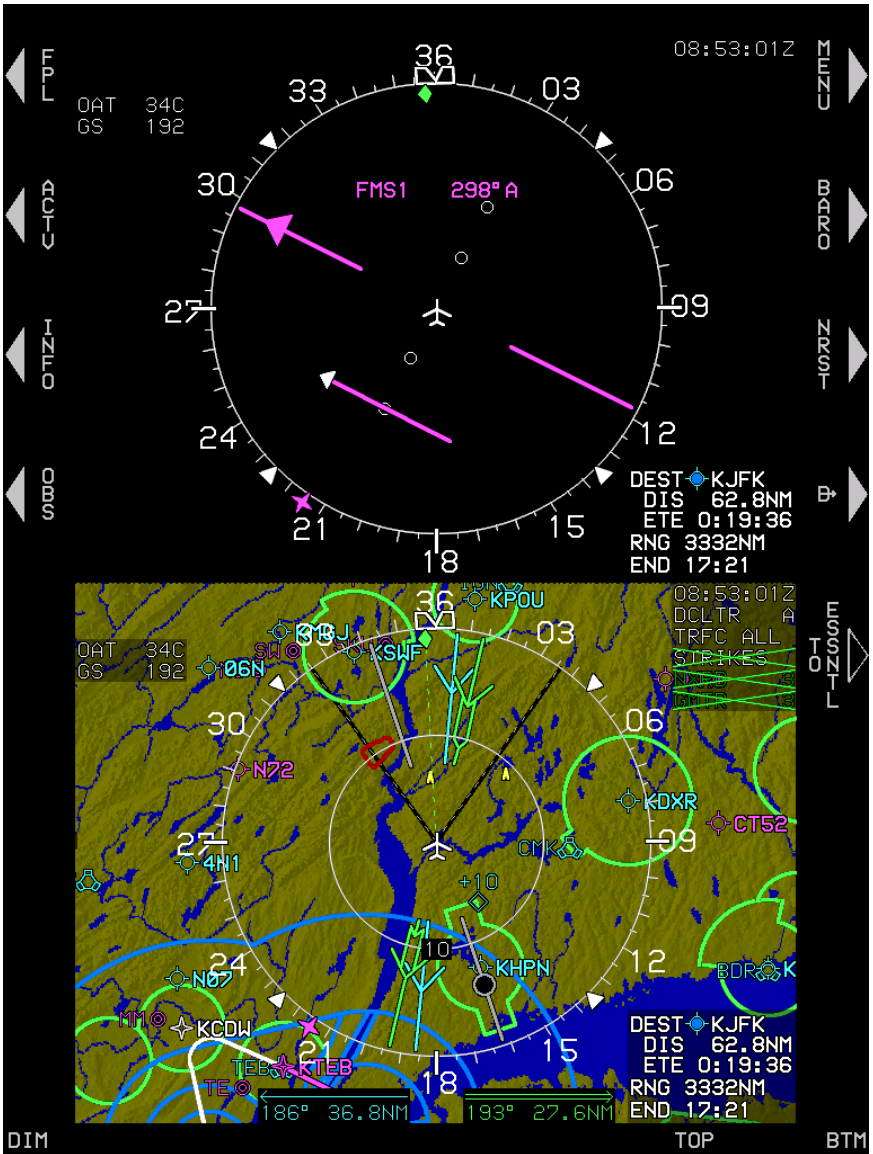

**Figure 4-23: MFD Failure Mode 6 (Normal Mode)
ADC and AHRS Failed, GPS/SBAS Normal**

4.9.2. MFD Failure Mode 6 (Essential Mode)



**Figure 4-24: MFD Failure Mode 6 (Essential Mode)
ADC and AHRS Failed, GPS/SBAS Normal**

4.10. PFD Failure Mode 7

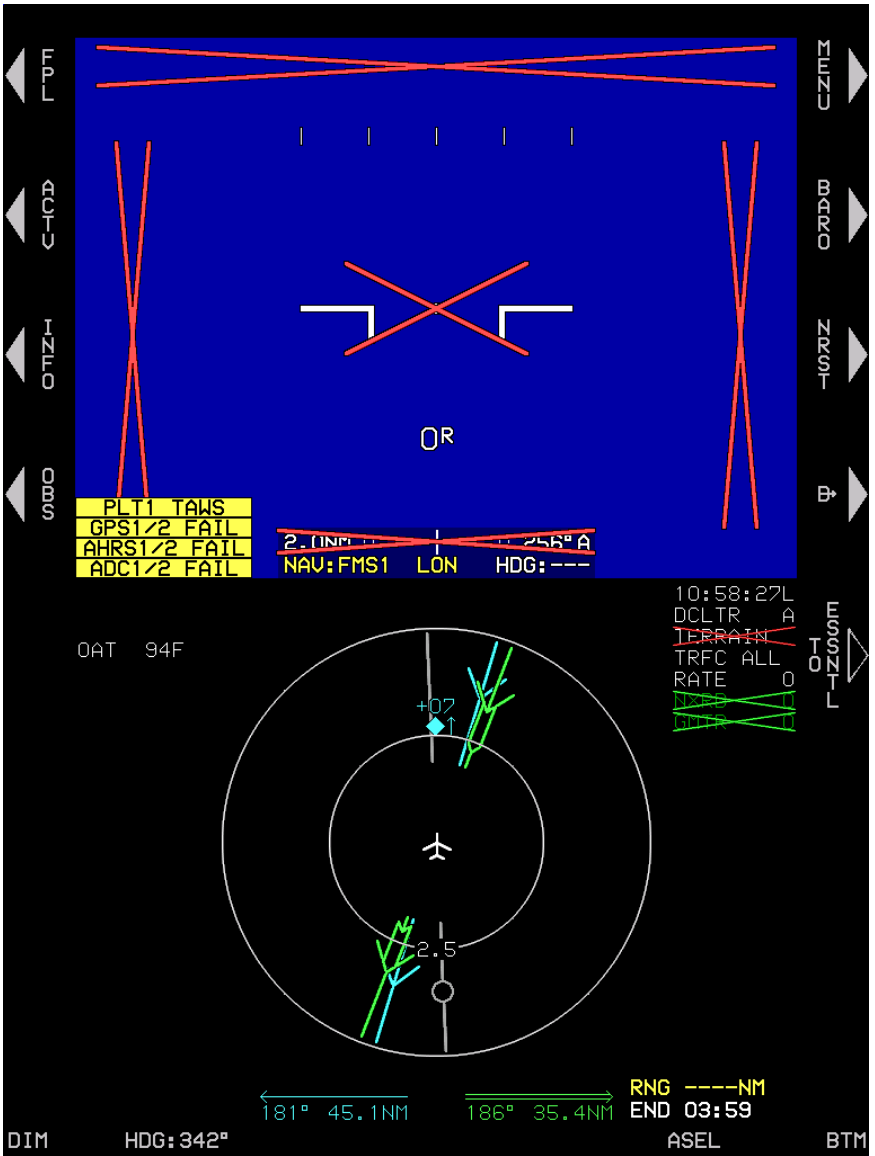

**Figure 4-25: PFD Failure Mode 7
GPS/SBAS, ADC and AHRS Failed**

4.10.1. MFD Failure Mode 7 (Normal Mode)

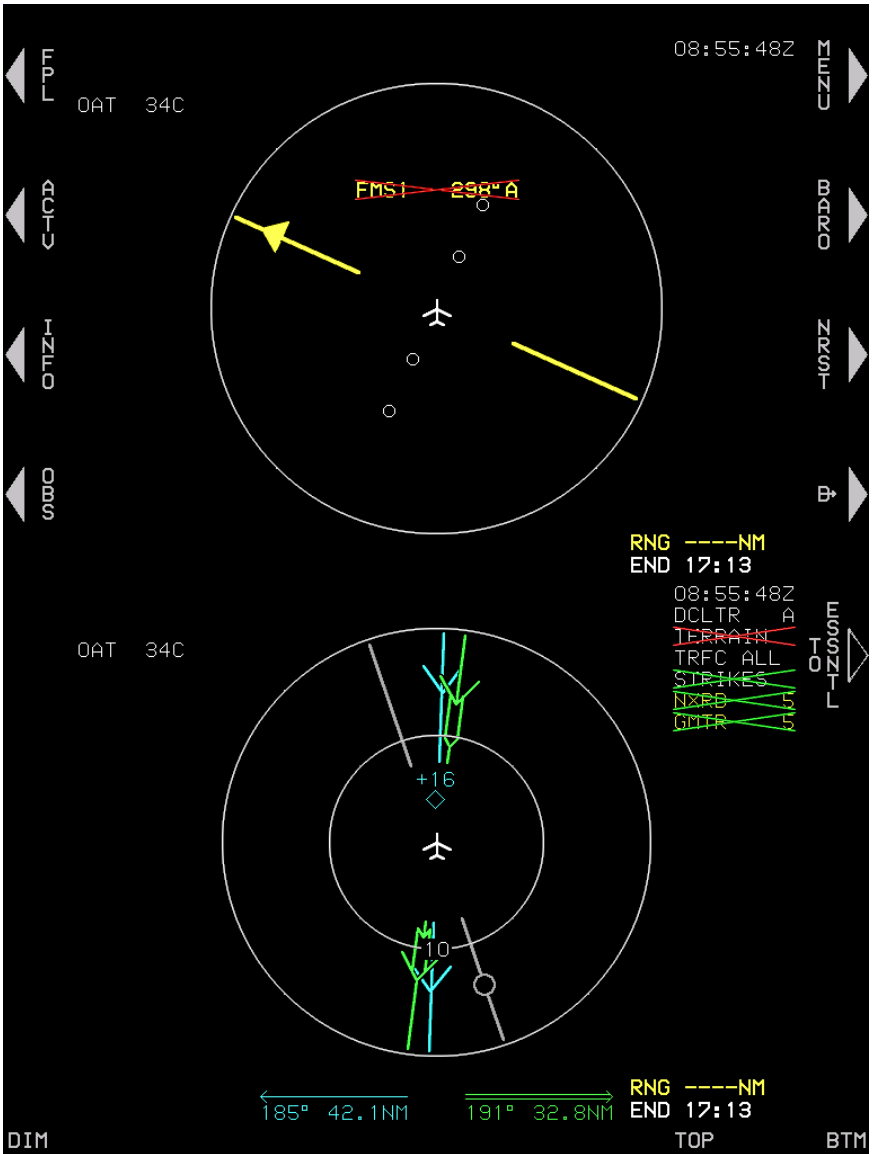

**Figure 4-26: MFD Failure Mode 7 (Normal Mode)
GPS/SBAS, ADC and AHRS Failed**

4.10.2. MFD Failure Mode 7 (Essential Mode)

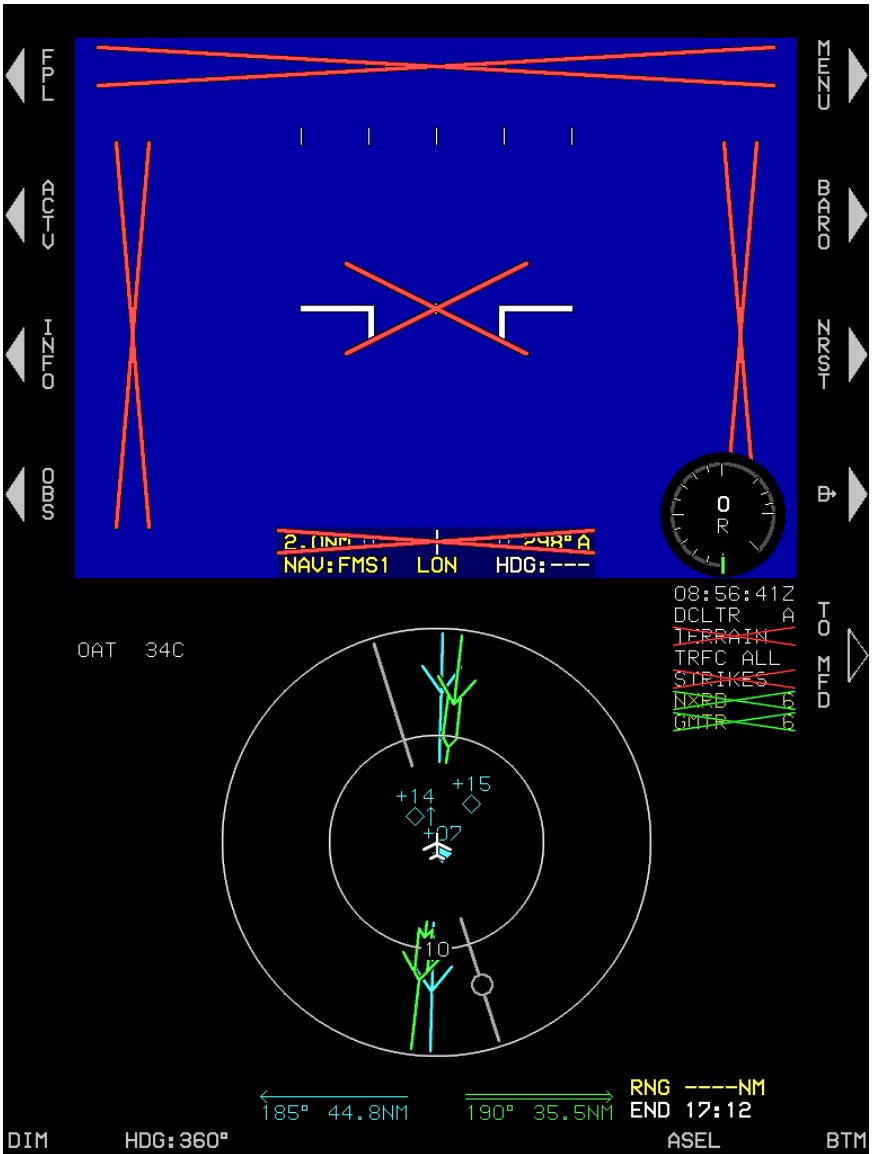

**Figure 4-27: MFD Failure Mode 7 (Essential Mode)
GPS/SBAS, ADC and AHRS Failed**

Section 5 Menu Functions and Step-By-Step Procedures

5.1. Menu Functions

Navigate menu functions with the 16 peripheral buttons and 4 encoders (4, 3, 2, and 1), except 4 is only used for adjusting screen and button brightness and cannot be used for menu functions. It is always labeled **DIM**.



Figure 5-1: IDU-680 Input Controls

5.1.1. Menu Philosophy

The menu system and buttons with an action are clearly labeled. The following rules are in the design of the menu system:

EXIT (R1): Whenever menu system is beyond the top level, provides a one-touch escape to the top-level.

BACK (L1): Whenever soft menu level is deeper than the first level, regresses through the menu system by one level.

Soft menu tiles: Used (even at the top-level) and are annunciated in a dedicated, blacked-out area in the screen margins adjacent to the appropriate IDU button or encoder when appropriate.

Selection list: Menus adjacent to encoders are frequently a selection list. Within lists, a two-dot trailer indicates further menu levels. Lists too long to be presented in the space available provide an indication of location within the list. Menu messages are displayed for five seconds but are cleared if any IDU button is pressed or encoders **1**, **2**, or **3** are pushed or rotated.



Indication of further menu levels: A filled triangle next to a menu legend means the button press leads to a further menu level. An empty triangle next to a menu legend means the button press is a final action.

Figure 5-2: Indication of Further Menu Levels

5.1.2. Avoidance of Autonomous Behavior

The displays are designed to be under the control of the pilot to ensure critical functions are placed at the top level (i.e., **TO ESSNTL**). Autonomous changes in function are avoided to the most extent possible. The following autonomous behaviors incorporated into the IDUs, all of which are required by regulation or guidance.

Automatic popup of flight instruments: For IFR approval in aircraft, flight instrument information essential to flight safety must remain available to the pilot without additional crewmember action after a failure. This guidance is specific to flight instruments, but it does not address powerplant or navigation instruments. This requirement is met by assigning an order of precedence of the IDUs based upon the IDU number. IDU #1 always shows the essential flight instruments, because the PFI page is always shown in the top area. Lower priority IDUs monitor the higher priority IDU via intra-system communications and automatically switch to essential mode upon determining the higher priority IDU has failed.

TAWS popups: When an FLTA alert is generated, a popup function enables PFI SVS (returns PFI to screen showing synthetic vision display) and activates terrain at an appropriate scale and format on the moving map page (one of the multi-function pages). This is a required function of TSO-C151 (Class A, B and C TAWS are described in Section 8 Terrain Awareness Warning System.)

Traffic popups: See Traffic appendix

5.2. Menu Synchronization

System settings changed by the menu system are synchronized between multiple IDUs and between top and bottom areas of an IDU-680 in MFD-MFD mode according to Table 5-1. All parameters for fixed wing aircraft are included. Each appendix for Traffic, Strikes, Datalink, WX-RDR, and Video contains specific limitations for menu synchronization for that feature.



Table 5-1: Menu Synchronization

Menu Parameter	Notes
<i>The following menu parameters are synchronized across all displays at all times. These are bugs and fundamental aircraft values that should never have independence.</i>	
AHRS 1 and 2 mode and slewing values	
Fuel Totalizer Quantity	
VNAV Climb Angle	
Countdown Timer Start Time	
Countdown Timer Default Value	
Remote Tune Frequencies	
VNAV Descent Angle	
G-Force Limit Parameters	
Decision Height Setting	Dependent upon EFIS Limits "Dual DH enabled"
Emergency and Minimum Fuel Settings	
G-Force Limit Parameters	
Heading Bug and Heading Sub-Mode	
High Weight V_{NE} selection	
Minimum Altitude Bug Value	
VLOC OBS Settings	
Roll Trim parameter	
Airspeed Bug Setting	
Target Altitude Bug Setting	
Timer Starting Signal	
True North Mode	
UTC Offset	
Settable V-Speeds	

Table 5-1: Menu Synchronization

Menu Parameter	Notes
VSI Bug Setting	
Crosslink Synchronization Status	
<p><i>The following menu parameters are synchronized across all displays when crosslink is enabled. Otherwise, they are only synchronized onside. These parameters are FMS parameters and allow the pilot and co-pilot FMSs to be operated independently when crosslink is inhibited.</i></p>	
Active Flight Plan Parameters	
Runway Display Parameters	
<p><i>The following menu parameters are only synchronized onside. These parameters are usually sensor selections or PFD options used to keep the appearance of any pilot's PFD consistent in the case of PFD reversion. The onside characteristic means that individual pilots can still adjust their PFD settings to their preference.</i></p>	
Sensor Selections	
Barometric Setting Parameters (Baro, Transition alt, Set QFE Baro)	
Decision Height Setting	Dependent upon EFIS Limits "Dual DH not enabled"
Navigation Source	
PFD Basic Mode	
PFD Zoom Mode	
PFD Analog AGL	
PFD Analog G-Force Indicator	
PFD Full-time Bank Scale Flag	
PFD Flight Director Show Flag	
PFD Mini map Show Flag	
PFD Altitude (meters) Show Flag	

Table 5-1: Menu Synchronization

Menu Parameter	Notes
PFD Skyway Show Flag	
PFD Terrain Show Flag	
Rate of turn indication flag	
<p><i>The following menu parameters are independent between displays. These are used to support non-PFD display options to give the pilot maximum MFD operating flexibility. Note that some of these parameters are also independent between top and bottom 680 MFD areas as specified in the notes.</i></p>	
<div style="display: flex; justify-content: space-around; align-items: center;"> <div style="border: 2px solid red; padding: 5px;">  </div> <div style="border: 2px solid red; padding: 5px;">  </div> </div>	
CPU Type	To support mixed CPU type installations
MFD Show ETA Flag	
680 Essential Mode Status	Support for 680 reversion
MFD Map and HSI Page (DCLTR) Pointer Settings	Independent between top and bottom 680 MFD areas
MFD Map Function Declutter Settings	
MFD Map NavData® Symbol Declutter Settings	

5.3. Top-Level Menu

On the IDU-680, the top-level menu consists of soft menu options along with option labels for the encoders.

5.3.1. IDU-680 PFD Normal Mode Top-Level Menu

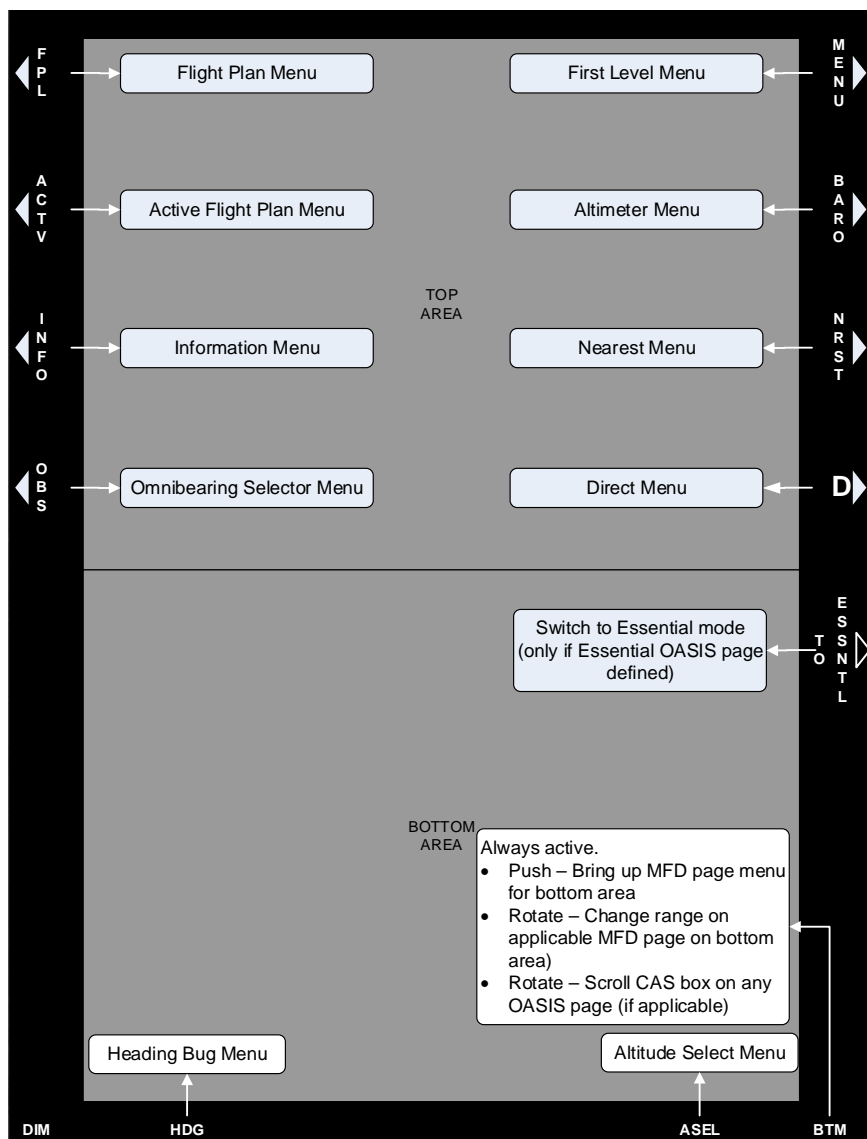

Figure 5-3: PFD Top-Level Menu (Normal Mode)

5.3.2. IDU-680 MFD Normal Mode Top-Level Menu

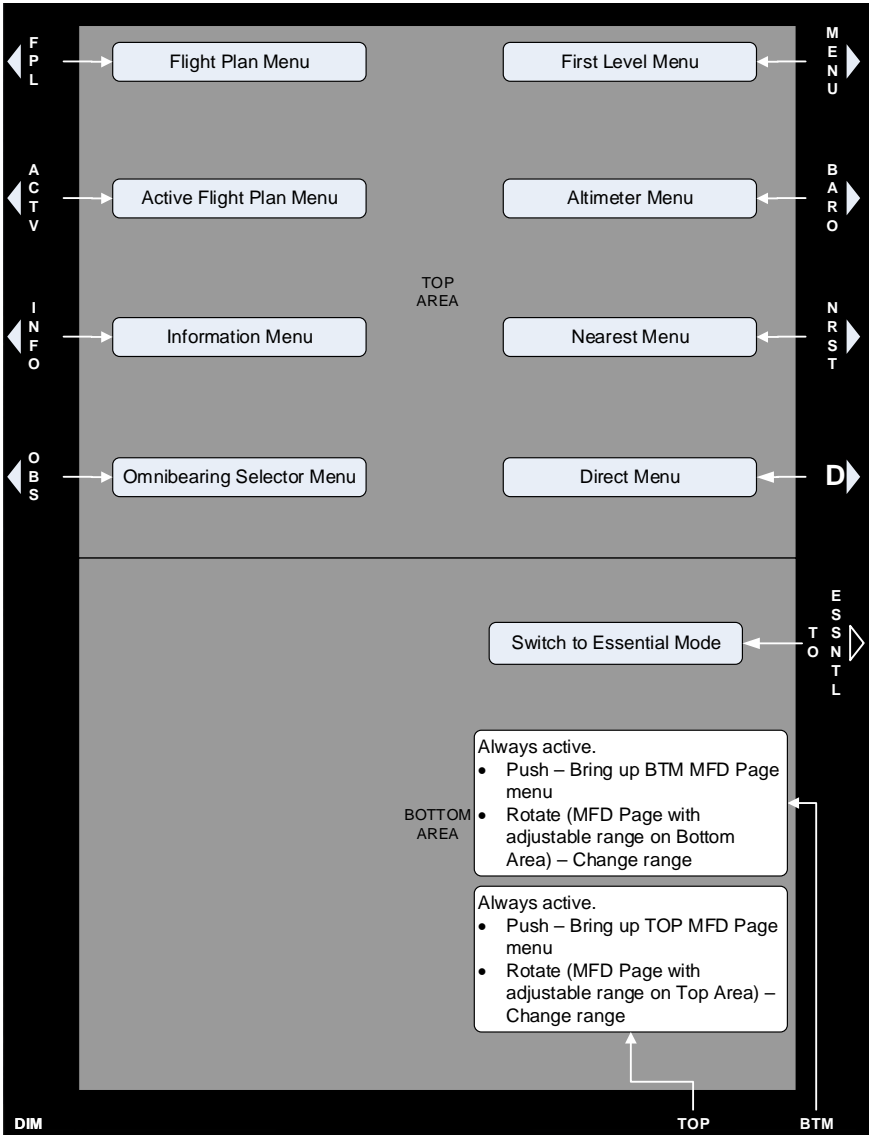

Figure 5-4: MFD Top-Level Menu (Normal Mode)

5.3.3. IDU-680 MFD Essential Mode Top-Level Menu

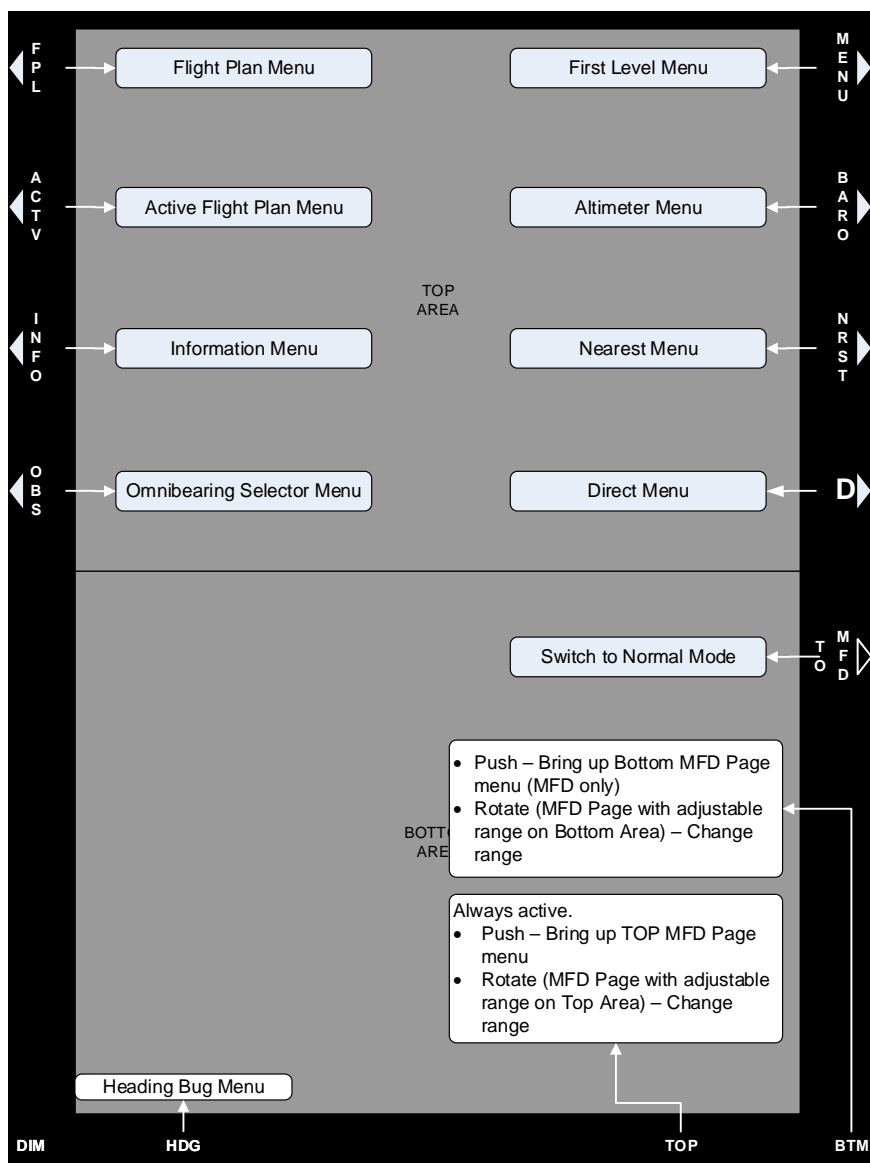

Figure 5-5: MFD Top-Level Menu (Essential Mode)

5.3.4. Audio Radio Management Optional Page

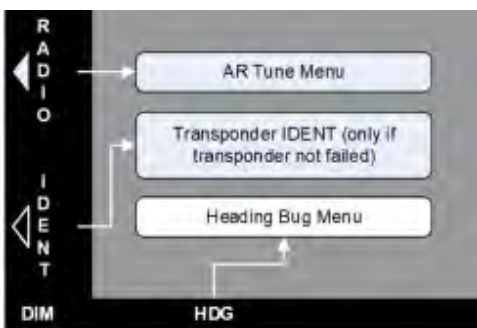



Figure 5-6: PFD or MFD Essential Mode Top-Level Menu with Audio Radio Management Option

The optional Audio/Radio page serves as a common interface for viewing the status of multiple AR devices. The AR menu always appears in the bottom area of the PFD and MFD, when configured, the talker IDU may have a specifically configured radio frequency panel (RFP). There are a maximum of fourteen devices configured and displayed at one time.

5.3.5. Top-Level Menu Option Descriptions

- 1) **FPL (L1)**: Flight plan menu
- 2) **ACTV (L2)**: Active flight plan menu § 5.8.1
- 3) **INFO (L3)**: Information menu
- 4) **OBS (L4)**: Omnibearing selector menu
- 5) **MENU (R1)**: First-level associated with the current display page and automatically times out after ten seconds if there are no subsequent pilot actions.
- 6) **BARO (R2)**: Altimeter menu
- 7) **NRST (R3)**: Nearest menu § 5.8.1
- 8) ** (R4)**: Direct menu § 5.8.1
- 9) **TO ESSNTL/TO MFD (MFD only)**: Switches between normal and essential modes.
- 10) **DVI (R7)**: Switches control of IDU screen to an external DVI source.

- 11) **3 Encoder:** Function depends upon IDU number and mode (Normal vs. Essential) as follows:
- On a PFD (IDU #1), any action activates the HDG bug menu. When labeled **HDG**, push **3** to synchronize current heading and rotate to activate heading bug menu. Either push **3** to accept changes or press **EXIT (R1)**.
 - On an MFD (IDUs other than #1) operating in essential mode, any action activates the HDG bug menu. When labeled **HDG**, push **3** to synchronize current heading and rotate to heading menu. Either push **3** to accept changes or press **EXIT (R1)**.
- 12) **2 Encoder:**
- On a PFD (IDU #1), any encoder action activates the altitude bug menu. **2** is labeled **ASEL**.
 - On an MFD (IDUs other than #1) operating in normal mode, if the top area is showing a page with an adjustable display scale (e.g., Map, Strikes, Traffic, or Datalink), rotate **2** to change the display scale (direction of rotation dependent upon EFIS limits settings).
 - On an MFD (IDUs other than #1) operating in normal mode, push **2** to activate the top MFD page menu as described in § 5.22. The top MFD page menu appears above **2**, unlike other menu lists.
 - On an MFD (IDUs other than #1) operating in essential mode, any encoder action activates altitude bug menu. **2** is labeled **ASEL**.
- 13) **1 Encoder:**
- On a PFD or MFD operating in normal mode, if bottom area is showing a page with an adjustable display scale (e.g., Map, Strikes, Traffic, Video, or Datalink) rotate **1** direction of rotation dependent upon EFIS limits settings **1** is labeled **BTM**.

5.3.6. Top-Level Menu Automatic Pop-Up Function Descriptions

Soft menu tiles appear adjacent to buttons under the specified conditions.

Table 5-2: Top-Level Auto Pop-Up Function Descriptions

Note		Tile Legend and Action in Order of Precedence
1	2	
L1	L5	<ol style="list-style-type: none"> 1) As specified in Section 8 TAWS, RESET appears when a terrain popup occurs during a TAWS FLTA alert (NA MFD). 2) When MFD page with pan mode enabled, PN OFF appears. Press to disable pan mode. 3) When display is transmit enabled, MISS appears upon transitioning the final approach fix. Press to activate missed approach procedure. 4) When display is transmit enabled, LNAV appears when there is an active flight plan, heading bug sub-mode is active, and system is integrated with an analog AP. Press to deactivate heading bug sub-mode and resume guidance to active flight plan path. 5) When display is transmit enabled, HDG appears when LNAV sub-mode is active and system is integrated with an analog AP with HDG mode engaged. Press to deactivate LNAV sub-mode and resume guidance to heading bug.
L2	L6	<ol style="list-style-type: none"> 1) When MFD page with: (a) pan mode enabled or (b) information for the nearest highlighted waypoint shown and airport weather information is present in the information block, WX appears. Press to display textual METAR and TAF data for the airport. 2) When display is transmit enabled, CONT appears when in a holding pattern with further active flight plan legs after the holding pattern. Press to re-enable automatic waypoint sequencing to allow normal sequencing to the leg after the holding pattern. 3) When display is transmit enabled, RESUME appears when a MANUAL leg is active with further non-MANUAL active flight plan legs after the MANUAL leg. When RESUME is pressed, a Direct-To the waypoint following the MANUAL leg is activated. 4) When display is transmit enabled, VNAV appears when VNAV guidance is valid, selected altitude sub-mode is active, and system is integrated with an analog autopilot. Press to deactivate selected altitude sub-mode and resume guidance to VNAV path.

Table 5-2: Top-Level Auto Pop-Up Function Descriptions

Note		Tile Legend and Action in Order of Precedence
1	2	
		5) When display is transmit enabled, ARM appears when on final approach segment (between final approach fix and missed approach point). Press to arm missed approach procedure to activate automatically upon sequencing missed approach point.
L3	L7	When MFD page with pan mode enabled, NORTH appears. Press to shift center of page in the specified direction.
L4	L8	When MFD page with pan mode enabled. SOUTH appears. Press to shift the center of the page in the specified direction.
R2	R6	When MFD page with pan mode enabled, INFO or HIDE appears. Press to toggle information for nearest highlighted waypoint. See § 5.9 for the amount and type of information presented.
R3	R7	When MFD page with pan mode enabled, EAST appears. Press to shift the center of the page in the specified direction.
R4	R8	When MFD page with pan mode enabled, WEST appears. Press to shift the center of the page in the specified direction.
Note 1: Function tied to page in top area.		
Note 2: Function tied to page in bottom area or transmit enabled.		

5.4. PFD Page First-Level

Top area of IDU #1 is fixed to the PFD page. Select essential mode on other IDUs to show PFD page in the top area. PFD page first-level options are shown adjacent to the top eight buttons. Options may also appear on the bottom eight buttons as appropriate to the page shown in the bottom area. When an identical option is shown adjacent to both the top area and bottom area, the option is only shown adjacent to the top area.

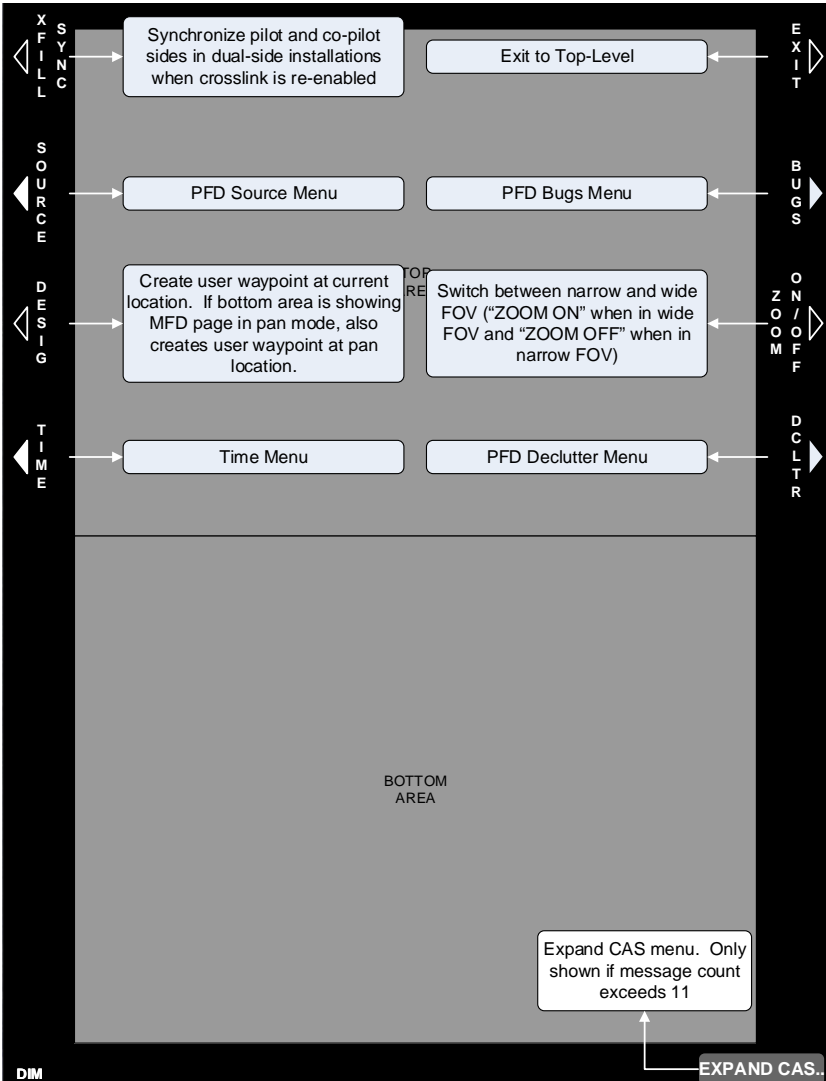

Figure 5-7: PFD Page First-Level

5.4.1. PFD Page First-Level Option Descriptions

- 1) **XFILL SYNC (L1)**: Appears in two-sided system installations where pilot and co-pilot sides are not synchronized but crosslink is enabled. Press to synchronize the pilot and co-pilot active flight plan parameters to the side where the button press occurred.

Table 5-3: Crossfill Inhibit/Arm/Sync Function

Crossfill ⁽¹⁾	Flight Plan	Indication (Pilot and Co-pilot)	Action to Synchronize Flight Plans		Result
			Pilot	Co-pilot	
Enabled (Cond.1)	Synchro-nized	None	None	None	No action required. Pilot and co-pilot sides already synchronized
Enabled (Cond.2)	Not Synchro-nized ⁽²⁾	XFILL ARM	MENU (R1) XFILL SYNC (L1)	None	Pilot's flight plan is sent to co-pilot side and both sides are synchronized going forward. XFILL ARM is removed from both sides.
			None	MENU (R1) XFILL SYNC(L1)	Co-pilot's flight plan is sent to pilot side and both sides are synchronized going forward. XFILL ARM is removed from both sides.
Inhibited (Cond.3)	Not Synchro-nized	XFILL INHBT	Enable crossfill ⁽¹⁾ (proceed to Cond. 2)		XFILL INHBT removed. XFILL ARM displayed on both sides.

(1) Crossfill is inhibited with the use of a latching (ON) crossfill inhibit switch. Crossfill is enabled by releasing (OFF) this switch.

(2) Pilot and co-pilot flight plans can become unsynchronized under the following conditions:

- 2) Crossfill is inhibited, and pilot and co-pilot flight plans are separately changed before crossfill is re-enabled.
- 3) Either the pilot or co-pilot side is restarted with an active flight plan on the other side and crossfill enabled.

- 4) **SOURCE (L2)**: Activates PFD source selection menu.

- 5) **DESIG (L3)**: Creates a user waypoint at current aircraft location. In addition, if pressed with an MFD page in pan mode, creates a user

waypoint at the panning location. User waypoint at current location is automatically named "OF###" where "###" is the next available over-fly user waypoint number. User waypoint at panning location is automatically named "PN###" where "###" is the next available panning user waypoint number. When **DESIG (L3)** is pressed and there are more than 998 user waypoints, the EFIS displays **USER WPTS FULL** message.

- 6) **TIME (L4)**: Activates time menu
- 7) **BUGS (R2)**: Activates the PFD bug set menu
- 8) **ZOOM ON/ZOOM OFF (R3)**: Toggles between wide FOV mode and narrow FOV mode.
- 9) **DCLTR (R4)**: Activates the PFD declutter menu.

5.5. First-Level (MFD)

The bottom area of all IDUs always shows the MFD page in all modes (essential OASIS page is a type of MFD page). IDUs other than IDU #1 may also show the MFD page in the top area in Normal mode. MFD page first-level options are shown adjacent to the area in which the MFD page resides. When an identical option is shown adjacent to both the top area and bottom areas, the option is only shown adjacent to the top area. (Options spelled the same but affect different areas of the display are not identical.) The MFD page first-level options are as follows.

NOTE:

For illustrative purposes, all possible options are shown in top area.

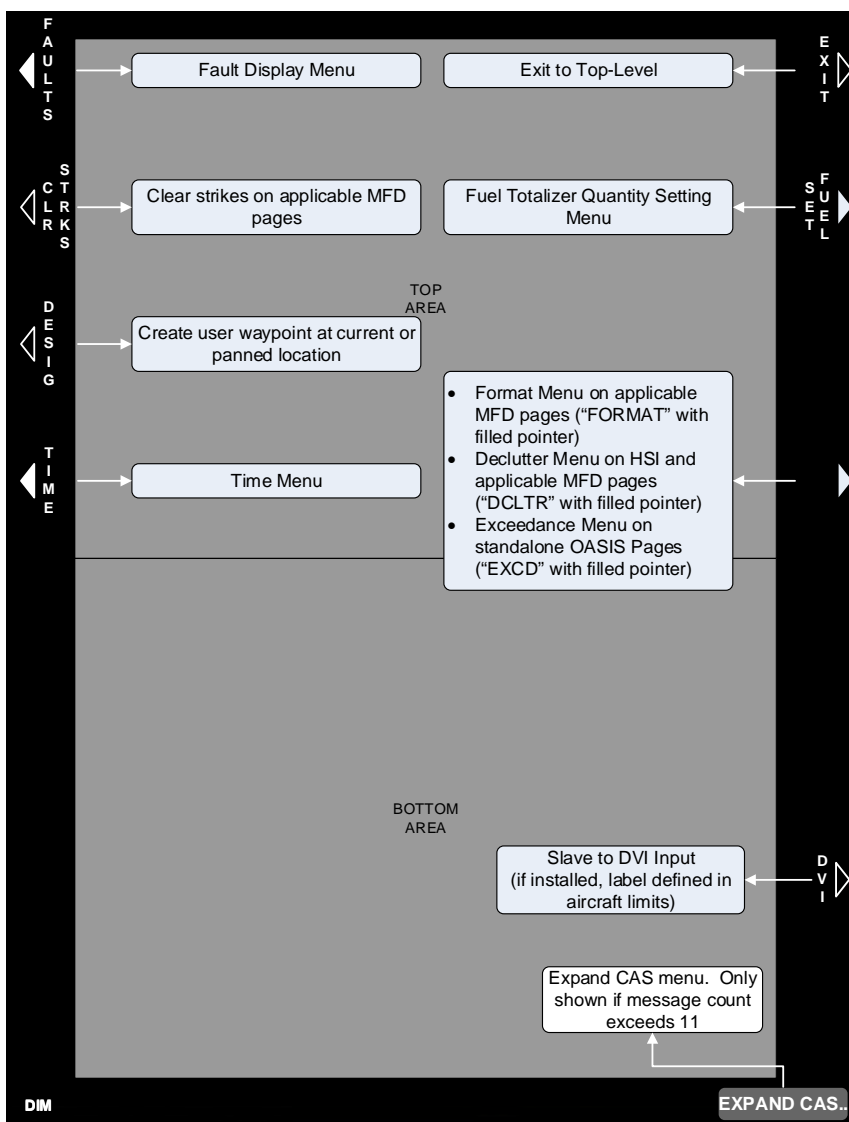

Figure 5-8: First-Level MFD

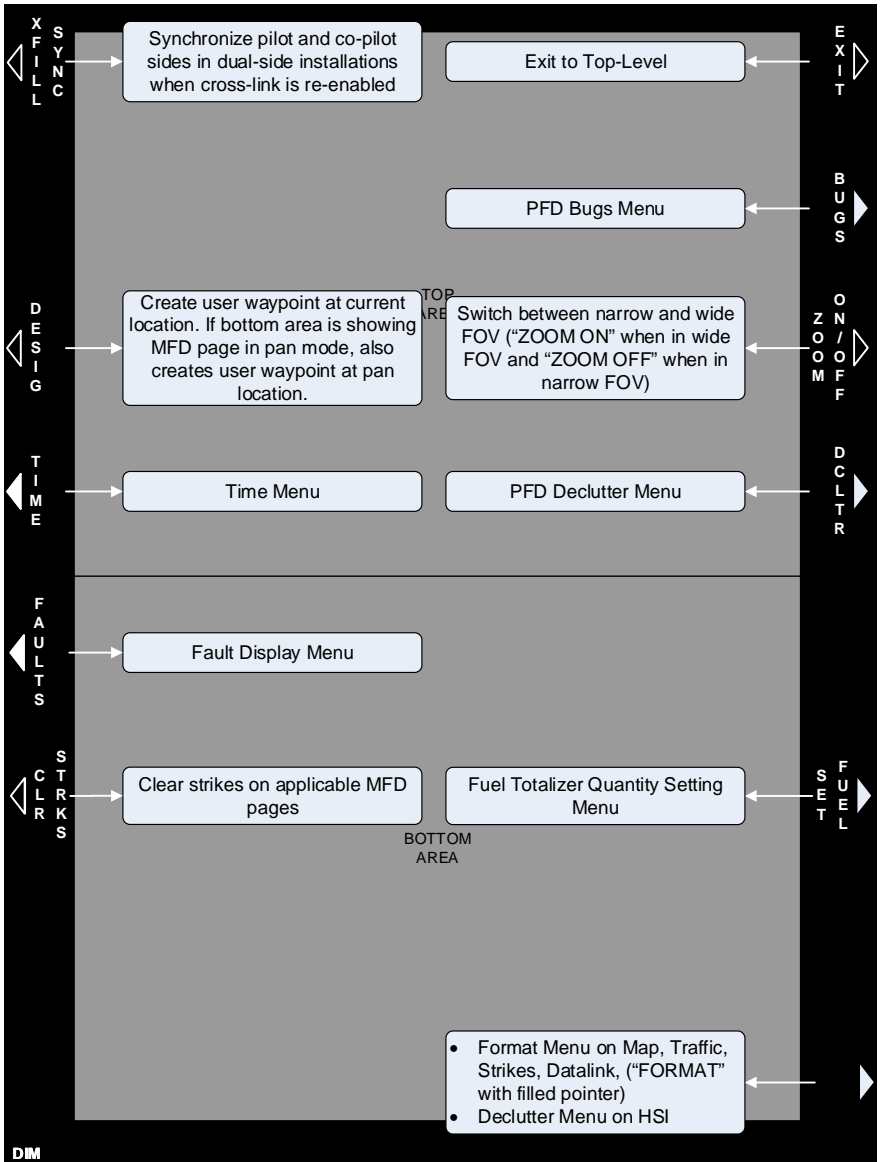

Figure 5-9: First-Level (PFD IDU #1) (PFI in Top Area and MFD in Bottom Area) (Normal Mode)

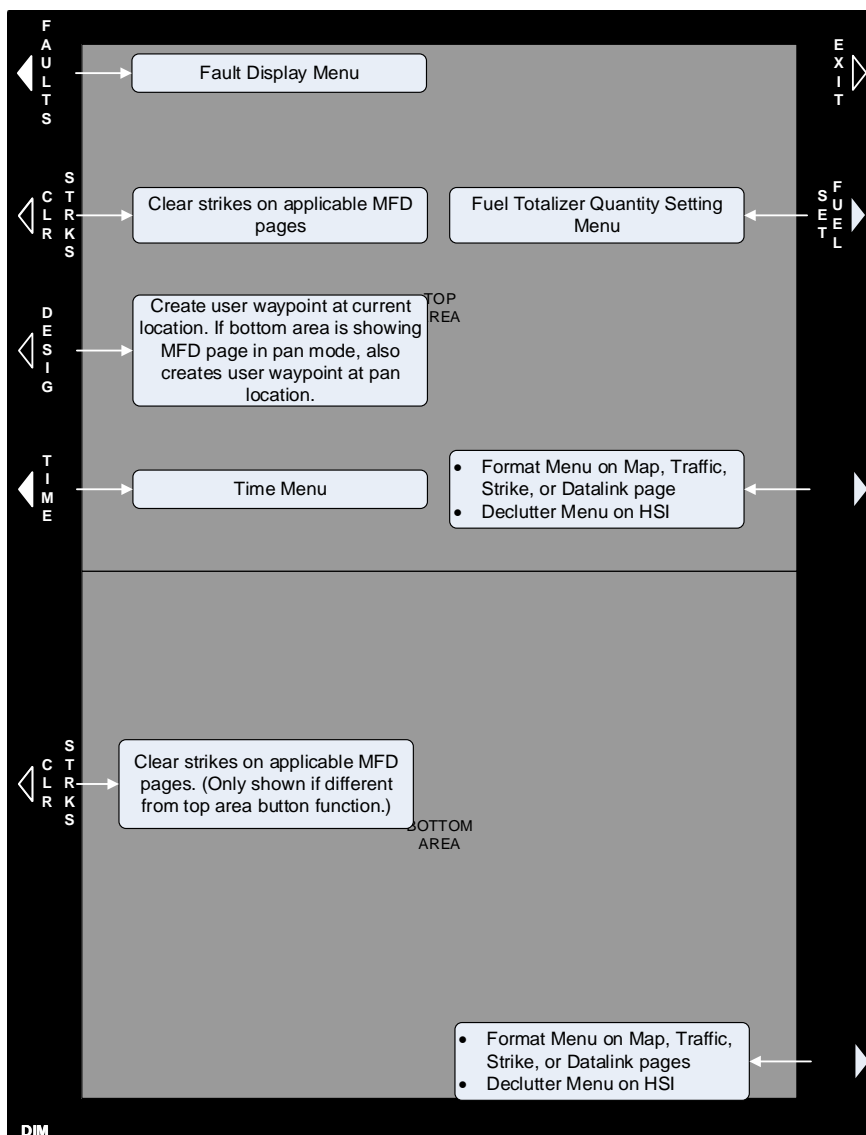

Figure 5-10: First-Level (MFD IDU #2) with an MFD Page in Both Areas (Normal Mode)

5.5.1. MFD Page First-Level Option Descriptions

- 1) **FAULTS (L1)**: Activates fault display menu
- 2) **CLEAR STRKS (L2)**: Activates the strike clear.
- 3) **DESIG (L3)**: Same function as first-level PFD page
- 4) **TIME (L4)**: Same function as first-level PFD page
- 5) **SET FUEL (R6)**: Activates fuel totalizer set menu
- 6) **FORMAT or DCLTR (R8)**: Activates appropriate page format menu.
 - a) **FORMAT**: On Map, Traffic, Strikes, and Datalink pages, activates the appropriate page format menu option.
 - b) **DCLTR**: On HSI page with VOR or ADF symbology enabled, activates HSI declutter menu option.
- 7) **DVI (R7)**: Switches control of the screen to an external DVI source. Label is defined by aircraft EFIS limits. (If discrete input is configured to perform this function, the label does not appear.) If a "Mission System" is incorporated, it is defined in the AFMS. When the IDU-680 MFD is placed into DVI, it can easily be returned to the EFIS by pressing **TO ESSENTIAL (R5)**.
- 8) **EXPAND CAS (R1)**: Activates the Expand CAS menu only when there are more than 11 active CAS messages.

5.6. Lower-Level Menus (Below First-Level)

The buttons and encoders, which control the top-level and first-level menus, called lower-level menus, are described in the following diagrams with button and encoder numbers as defined in Figure 5-1.

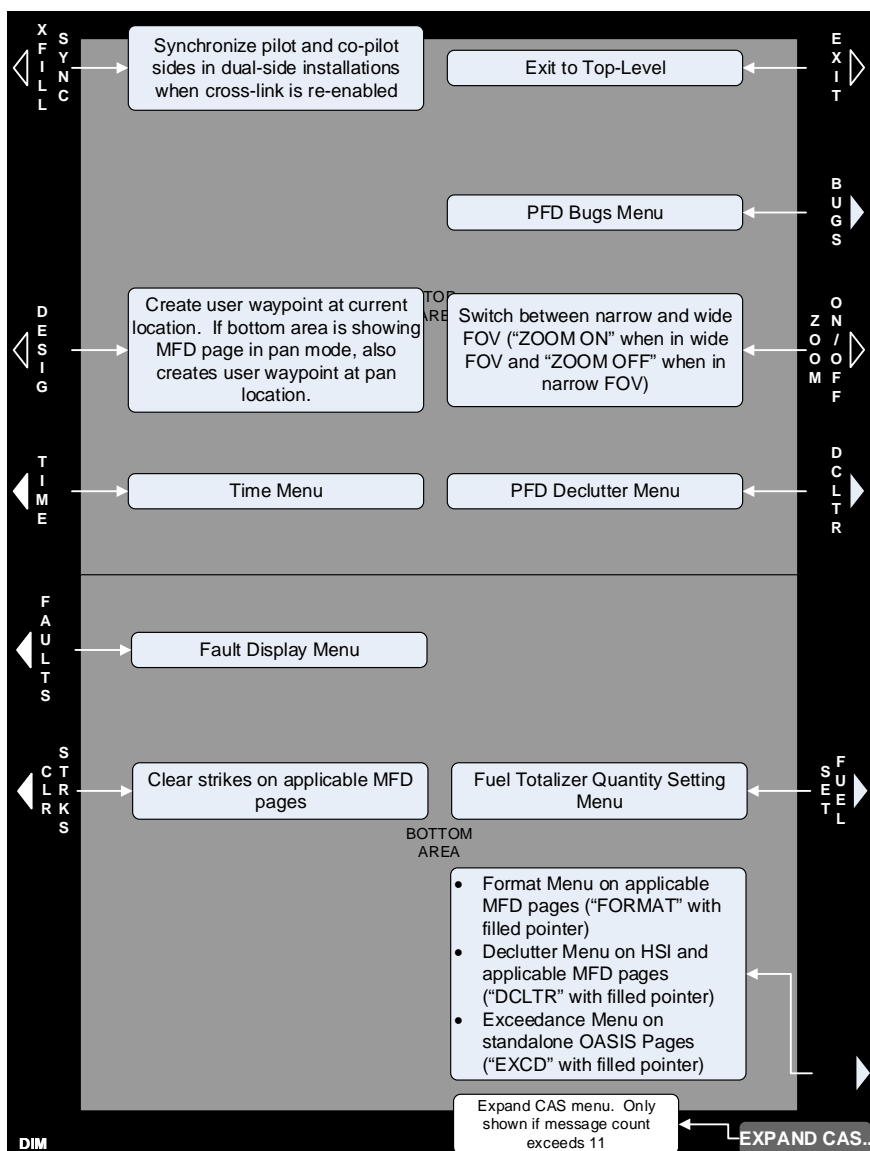

Figure 5-11: PFD Page in Top Area and Essential Mode OASIS Page in Bottom Area

5.6.1. OASIS Page First-Level in Essential Mode

The bottom area shows the OASIS page. In Normal mode on IDU #2, the OASIS page may be shown in the top area (full-screen OASIS page using both the top and bottom areas is considered a top area page). OASIS page first-level options are shown adjacent to the area in which the OASIS page resides. When an identical option is shown adjacent to both the top area and bottom area, the option is only shown adjacent to the top area.

5.7. Flight Plan (FPL) Menu

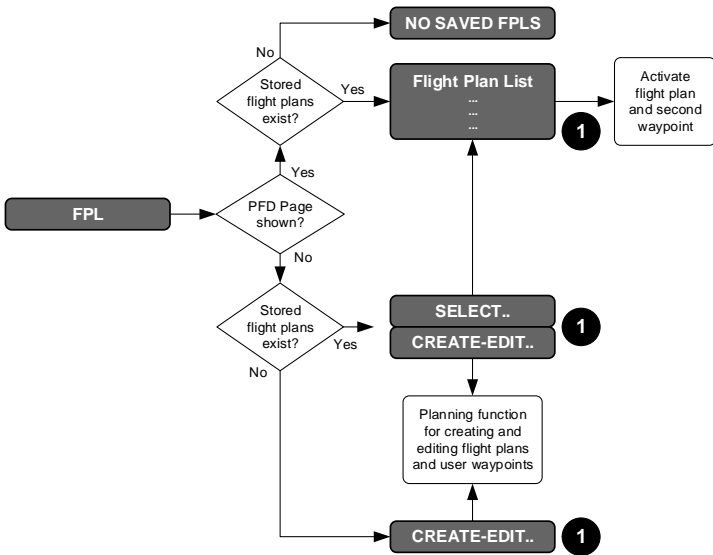

Figure 5-12: Flight Plan Menu (PFD or MFD)



Upon activation of the flight plan menu, the system checks for saved flight plans. If there are no saved flight plans, only **CREATE-EDIT..** encoder message appears. Otherwise, a list of saved flight plans is presented. Upon selection of a saved flight plan, the second waypoint in the flight plan is activated.

Figure 5-13: Select from Option List

Flight Plan Limits: Flight plans are stored routes (100 maximum) for repeated use without having to re-enter the waypoints each time. A flight plan consists of at least two waypoints (a start and an end) and may have up to 40 waypoints. Flights requiring more than 40 waypoints are divided into two or more flight plans.

5.7.1. Flight Planner Page

Perform following types of functions through the flight planner page.

- 1) Manage stored flight plans (activating, creating, editing, deleting, and reversing);
- 2) Manage user waypoints (creating, editing, and deleting); and
- 3) Perform RAIM predictions.

These operations demand pilot attention and are not a normal operating condition for the IDU. When the flight planner page is in use, it takes over the IDUs controls and disables the menu operations described. Normal menu operation and IDU control function are restored upon:

- 1) Exiting the flight planner page; or
- 2) Automatic reversion of the IDU to PFD or essential mode exits the flight planner page and wipes out any changes being performed.

NOTE:

Unless otherwise noted, the following step-by-step procedures are for the PFD or MFD.

Because the flight planner page takes over the IDUs controls, limitations are placed upon access and display of the flight planner page. When the flight planner page is accessed, it only appears in the bottom area.

5.7.2. Create an Overfly User Waypoint (Step-By-Step)



- 1) When flying over intended waypoint, press **MENU (R1)** and then **DESIG (L3)** on PFD or MFD.



- 2) A user waypoint is created at the present position and automatically named "OF###," where ### is the next available sequence overfly user waypoint number.



- Use **EDIT USER WPT** function to change the waypoint name or characteristics (see § 5.7.14).



NOTE:

A maximum of 998 user waypoints may be created and stored.

If a discrete input has been enabled as “Remote User Waypoint Designate,” it may be used to easily create a user waypoint.

5.7.3. Flight Plan (FPL) Menu Selecting (Step-By-Step)



- Press **FPL (L1)**.

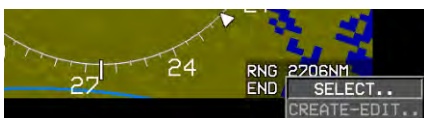

- Rotate **1** to **SELECT..** and push to enter.



- Rotate **1** to desired flight plan and push to enter.

5.7.4. Flight Plan (FPL) Menu Create-Edit (Step-By-Step)

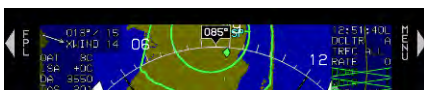

- Press **FPL (L1)**.



- Rotate **1** to **CREATE-EDIT..** and push to enter.

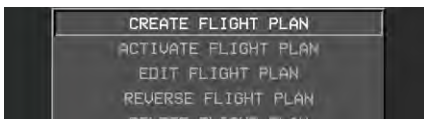

- Push **1** to enter.



- Press **ADD (R6)** to begin creating first waypoint.

5.7.5. Flight Plan (FPL) Menu Selection (Step-By-Step)



- 1) Press **FPL (L1)** and then rotate **1** to **CREATE-EDIT** and push to enter.



- 2) Press **NRST APT (L6)**, **NRST VOR (L7)**, **NRST NDB (L8)**, **NRST FIX (R6)**, **NRST USR (R7)**, or **AIRWAY (R8)** to view applicable list, rotate **1** to desired selection. Push to insert into flight plan.



- 3) As the flight plan creation continues, a blank space is created and ready for adding another waypoint by pressing **ADD (R6)**.



- 4) If necessary, rotate **1** to scroll up the list to LIML.



- 5) Press **INFO (L7)** and view information about selected waypoint.

5.7.6. Create Flight Plan (Step-By-Step)



- 1) Press **FPL (L1)** rotate **1** to **CREATE-EDIT** and push to enter.

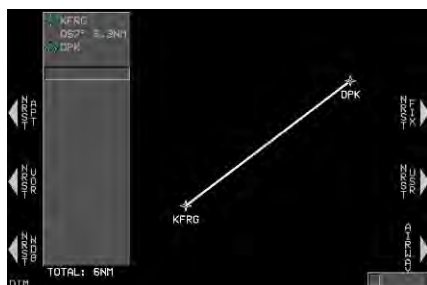

- 2) Press **ADD (R6)** and press **NRST APT (L6)**, **NRST VOR (L7)**, **NRST NDB (L8)**, **NRST FIX (R6)**, **NRST USR (R7)**, or **AIRWAY (R8)** to view applicable list, rotate **1** to desired selection. Push to insert into flight plan.

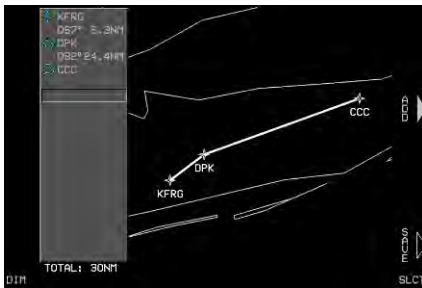

- 3) View current flight plan and press **ADD (R6)** to create additional waypoints or press **SAVE (R8)** if accepted to save flight plan on all displays.

5.7.7. Activate Flight Plan (Step-By-Step)



- 1) Press **FPL (L1)**.



- 2) Rotate **1** to **CREATE-EDIT..** and push to enter.



- 3) Rotate **1** to **ACTIVATE FLIGHT PLAN** and push to enter.

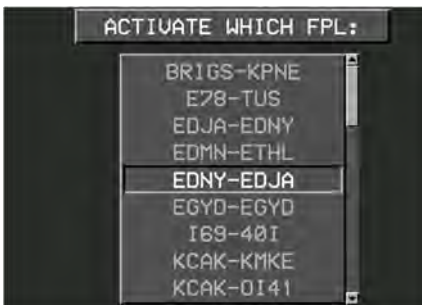

- 4) Rotate **1** to desired saved flight plan and push to enter.

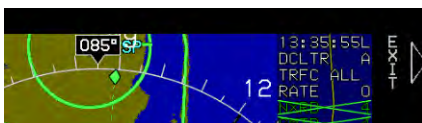

- 5) Press **EXIT (R1)** if no other action is necessary.

5.7.8. Edit Flight Plan (Step-By-Step)



- 1) Press **FPL (L1)**.



- 2) Rotate **1** to **CREATE-EDIT..** and push to enter.

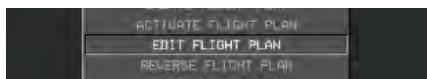

- 3) Rotate **1** to **EDIT FLIGHT PLAN** and push to enter.



- 4) Rotate **1** to desired flight plan and push to enter.

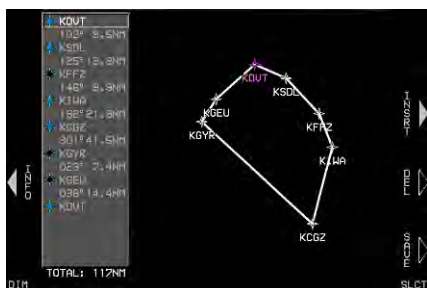

- 5) Edit flight plan by adding or deleting waypoints as appropriate.

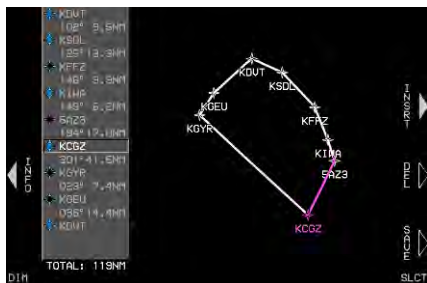

- 6) Press **SAVE (R8)** to save and exit to **EDIT WHICH FPL:** list.



- 7) Press **EXIT (R1)**, if no other action is necessary.

5.7.9. Reverse Flight Plan (Step-By-Step)



- 1) Press **FPL (L1)**.



- 2) Rotate **1** to **CREATE-EDIT..** and push to enter.

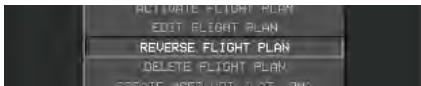

- 3) Rotate **1** to **REVERSE FLIGHT PLAN** and push to enter.

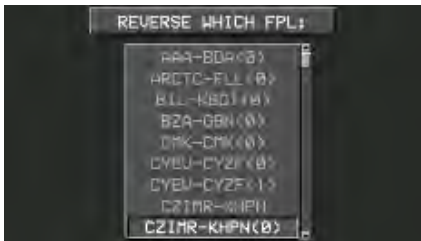

- 4) Rotate **1** to desired flight plan and push to enter.



- 5) If no other flight plan to reverse, press **EXIT (R1)**.

5.7.10. Delete Flight Plan (Step-By-Step)



- 1) Press **FPL (L1)**.



- 2) Rotate **1** to **CREATE-EDIT..** and push to enter.

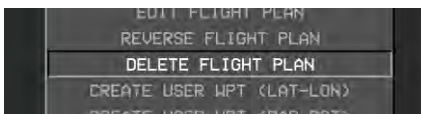

- 3) Rotate **1** to **DELETE FLIGHT PLAN** and push to enter.



- 4) Rotate **1** to flight plan to delete. Push to enter.



- 5) Push **1** to **CONFIRM DELETE FPL**.



- The next flight plan is highlighted for similar action if necessary.



- If no further deletions, press **EXIT (R1)**.

5.7.11. Changing Procedure in Active Flight Plan (Step-By-Step)

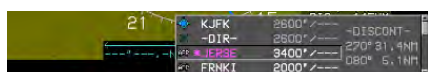

- Press **ACTV (L2)**.



- Rotate **1** to desired airport where new approach is to be entered and push to enter.



- Rotate **1** to **IFR APPR..** and push to enter.

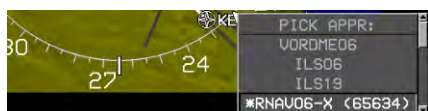

- Rotate **1** to desired instrument approach and push to enter.

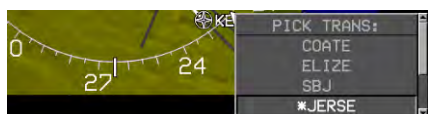

- Rotate **1** to desired transition (when applicable) and push to enter.

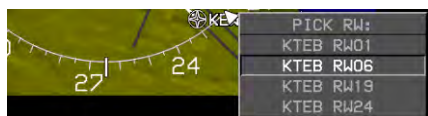

- Rotate **1** to desired runway and push to enter.



- If this new approach is to replace the initial procedure, push **1** to confirm. Use same procedure for changing a STAR **CONFIRM REPLACE STAR**, DP **CONFIRM REPLACE DP**, or instrument approach procedure **CONFIRM REPLACE APPROACH**.

5.7.12. Create User Waypoint (LAT-LON) (Step-By-Step)

User waypoints may be created with three methods:

- 1) Latitude and Longitude
- 2) Radial and Distance
- 3) Overfly (Designate)

To create a user waypoint using latitude and longitude, use the following step-by-step procedure.



- 1) Press **FPL (L1)**.



- 2) Rotate **1** to **CREATE-EDIT..** and push to enter.

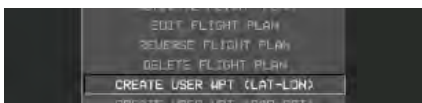

- 3) Rotate **1** to **CREATE USER WPT (LAT-LON)** and push to enter. (Maximum of 998 user waypoints saved)



- 4) To name a new user waypoint, rotate **1** and push to enter all five character spaces. (Spaces between characters and duplicate names are acceptable.)



- 5) With new user waypoint name created, push **1** to proceed through all fields as necessary.

Approach bearing preloading depends on mode of flight as follows:

On Ground: Preloaded with current heading

In Flight: Preloaded with "OFF" value.

If desired, specify the approach bearing to user waypoint in degrees 1°- 360°. "OFF" disables VFR approaches to the user waypoint.



- 6) Press **SAVE (R7)** to save user



waypoint or press **(R8)** to create RUFUS as the active waypoint and begin navigation guidance.

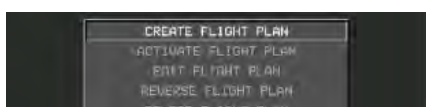

- 7) Once all fields are entered, press **SAVE (R7)** to save changes and store user waypoint as one of the 998 user waypoints. EFIS returns to **CREATE FLIGHT PLAN** at the top of the list. Press **EXIT (R1)** to exit menu.



5.7.13. Create User Waypoint (RAD-DST) (Step-By-Step)



- 1) Press **FPL (L1)**.



- 2) Rotate **1** to **CREATE-EDIT..** and push to enter.



- 3) Rotate **1** to **CREATE USER WPT (RAD-DST)**. Push to enter. (Maximum of 998 user waypoints saved)

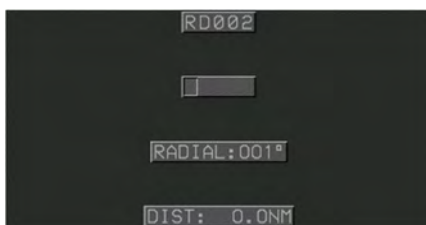

- 4) Identifier is automatically named RD### where ### is the next available radial distance waypoint number.

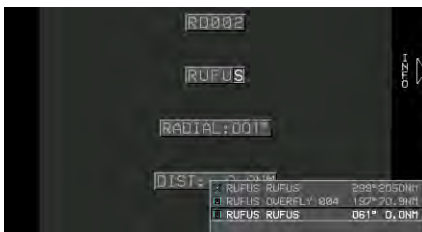

- 5) User waypoint RUFUS is selected from list of other waypoints with the same name spelling. Rotate/push **1** to enter with the desired user waypoint highlighted.

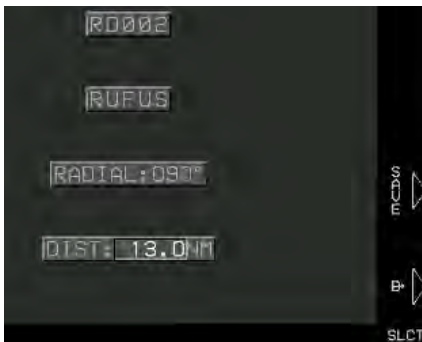

- 6) Rotate/push **1** to enter identifier for reference waypoint and RADIAL/DIST values, and then either press **SAVE (R7)** user waypoint or press **DN (R8)** to create RD002 as the active waypoint and begin navigation guidance.

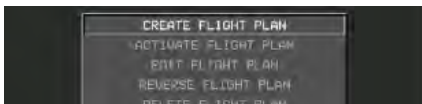

- 7) EFIS returns to **CREATE FLIGHT PLAN** option at the top of the list.



- 8) Press **EXIT (R1)** to exit menu.

5.7.14. Edit User Waypoint (Step-By-Step)



- 1) Press **FPL (L1)**.



- 2) Rotate **1** to **CREATE-EDIT..** and push to enter.



- 3) Rotate **1** to **EDIT USER WPT** and push to enter.

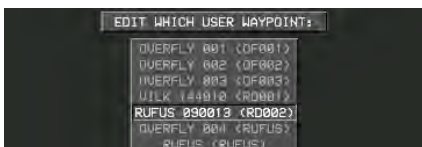

- 4) Rotate **1** to waypoint to be edited. Push to enter.

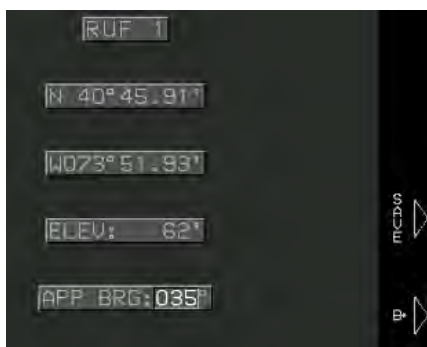

5) Use **1** to enter alphanumeric characters and follow prompts to edit information. Push **1** to step through all character spaces. To back up, press **BACK (L1)** and continue to the end of all character spaces. (Spaces and duplicates are acceptable)



6) Either press **SAVE (R7)** to save user waypoint or press **ENTER (R8)** to create RUF 1 as the active waypoint and begin navigation guidance.



7) Select another waypoint to edit or press **EXIT (R1)** to save changes.

5.7.15. Delete User Waypoint (Step-By-Step)



1) Press **FPL (L1)**.



2) Rotate **1** to **CREATE-EDIT..** and push to enter.



3) Rotate **1** to **DELETE USER WPT** and push to enter.

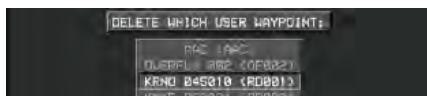

4) Rotate **1** to desired waypoint to be deleted.



5) Push **1** to **CONFIRM DEL USER WPT**.



6) If no more waypoints to delete, press **EXIT (R1)**.

NOTE:

Alterations of user waypoint parameters while in flight do not automatically update to an active flight plan.

If changes are made to a user waypoint in existing flight plans that use the waypoint, it must be deleted and replaced in the flight plans with the following steps:

- 1) Edit the user waypoint as described above
- 2) Open a flight plan that uses the user waypoint
- 3) Delete the existing waypoint from the flight plan
- 4) Save and exit
- 5) Reload the flight plan if it was in use.

5.7.16. RAIM Prediction (Step-By-Step)

When selected, the RAIM prediction screen is only shown if the GPS/SBAS receiver is capable of performing a RAIM prediction (not suitable for enroute predictions). This requires there be no faults along with a current almanac in memory. Check FAULTS menu (on PFD or MFD) to determine if the GPS/SBAS receiver is capable of performing a RAIM prediction.



- 1) Press **FPL (L1)**.



- 2) Rotate **1** to **CREATE-EDIT..** and push to enter.



- 3) Rotate **1** to **RAIM PREDICTION** and push to enter.

SEE NOTE BELOW.

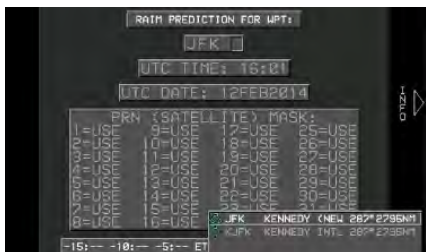



- 4) If another RAIM prediction is necessary, press **START OVER (R6)** or press **EXIT (R1)**.

NOTE:

The pilot may perform RAIM prediction at a designated waypoint. The screen has various data entry boxes as follows.

- 1) **Designated Waypoint:** Enter an identifier for the designated waypoint. If there is a single result from the search, the pilot is advanced to the UTC time entry box. If there is no result from the search, the pilot is re-prompted to enter an identifier. If there are multiple results from the search, a selection list with matching identifiers is presented and, upon selection, the pilot is advanced to the UTC time entry box. **INFO (L3)** gives information for the highlighted results.
- 2) **UTC Time Entry:** Enter the 24-Hour UTC estimated time of arrival at the designated waypoint.
- 3) **UTC Date Entry:** Enter the UTC estimated date of arrival at the designated waypoint.
- 4) **PRN Mask Entry:** (“Pseudo-random noise” sequences, or gold codes, that each satellite transmits to differentiate itself from other satellites in the active constellation). Specify the PRN number of satellites expected to be unavailable at the destination.
- 5) **EXIT:** Exit the RAIM prediction screen at any time.
- 6) Once a designated waypoint and UTC estimated time of arrival are entered, **CALC (R6)** appears. Press **CALC (R6)** to check the UTC estimated time of arrival and ensure it is within the current almanac (i.e., <3.5 days from current date and time). If it is, a predictive FDE request message requesting “detection availability” with a required HAL of 0.3NM is sent to the GPS/SBAS receiver. In response, the GPS/SBAS receiver replies with a sequence of predictive FDE response messages. These messages are parsed and used to fill in the RAIM prediction result area at the bottom of the screen. The RAIM prediction result area shows the RAIM prediction results as “OK” or “XX” for ETA \pm in 5-minute increments. Once a prediction is complete, press **START OVER (R6)** to perform another prediction (if necessary) without exiting the RAIM prediction menu.

5.8. Active Flight Plan (ACTV) Menu

See Section 7 IFR Procedures for active flight plan description.

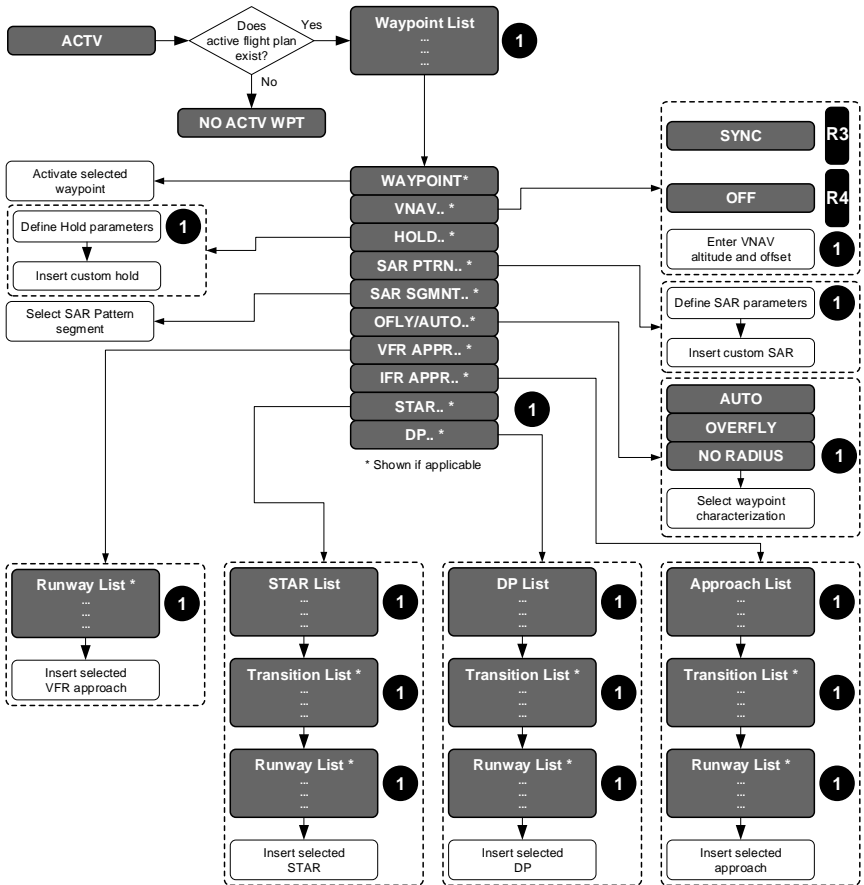

Figure 5-14: Active Flight Plan Main Menu

Various options appear at the same menu level as the Nav Log selection list. The following options allow various modifications to be made to the active flight plan.

5.8.1. Active Flight Plan (ACTV) Menu Options

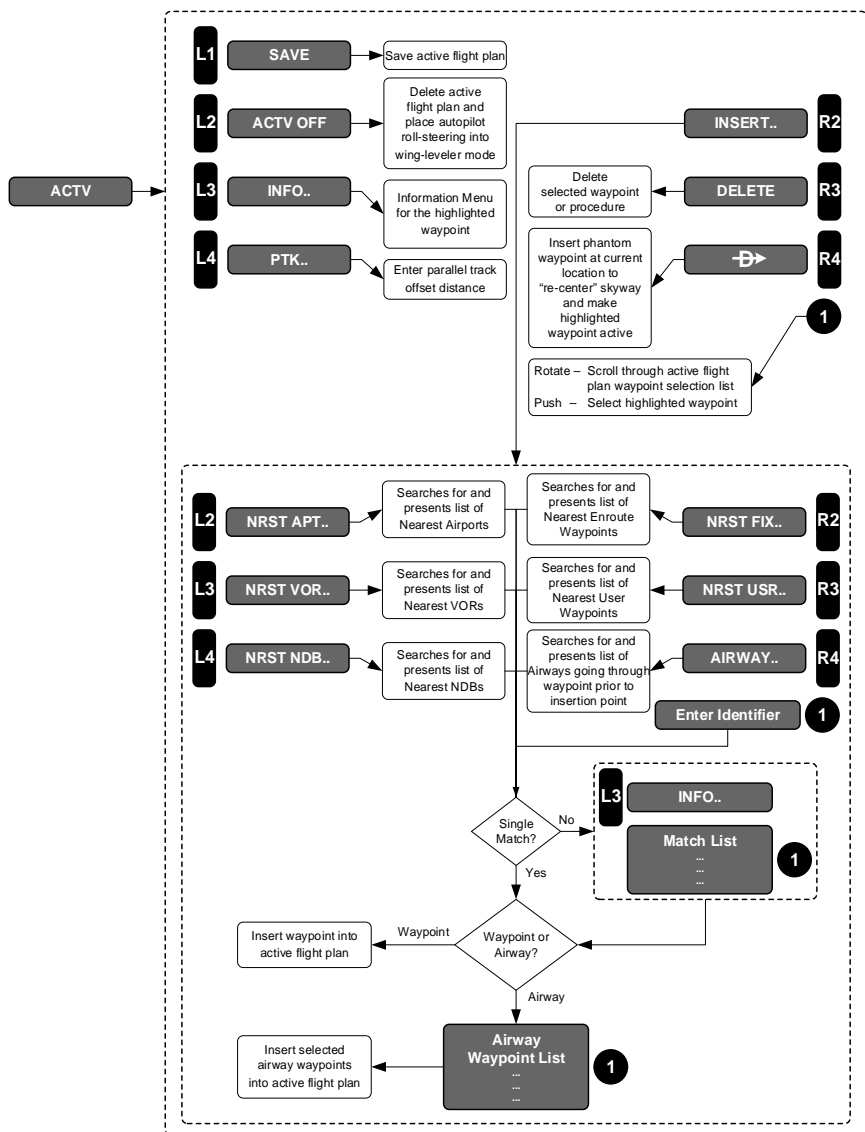

Figure 5-15: Active Flight Plan Menu Options

Table 5-4: Active Flight Plan Menu Options

Menu Options	Action for Active Flight Plan	Search Limits	Limitations
SAVE (L1)	Saves and is part of 100 stored flight plans	N/A	Saves without procedures or phantom waypoints. Named by first and last waypoints.
ACTV OFF (L2)	Deletes		Prompted to confirm deletion.
INFO (L3)	Activates information menu for the highlighted waypoint.		With no active flight plan, activates information for nearest airport.
PTK (L4)	If active leg is eligible for offset, allows pilot to specify parallel offset distance for non-procedure segments.		20NM left or right in 1NM increments.
INSERT/ ADD (R2)	Insert or add a waypoint or airway.		<p>ADD: At end of active flight plan.</p> <p>INSERT: Above highlighted waypoint.</p> <p>SEARCH: Requires minimum of two characters.</p> <p>INFO: After adding waypoint, appears to aid in selection.</p> <p>AIRWAY: Search for all airways going through highlighted waypoint. Offers option to select exit waypoint.</p>
NRST APT (L2)	Search for airports of runway length criteria set in EFIS limits.	Search for 20 items within 240 NM nearest to the waypoint prior	<p>NO RESULTS: No eligible airports within search area or selection list includes bearing, distance to each result.</p> <p>INFO: After adding waypoint, aids in selection.</p>

Table 5-4: Active Flight Plan Menu Options

Menu Options	Action for Active Flight Plan	Search Limits	Limitations
NRST FIX (R2)	Search for fixes	to the insertion point.	<p>NO RESULTS: No fixes within search area or selection list includes identifier, bearing and distance to each result.</p> <p>INFO: Provides information and aids in selection.</p>
NRST NDB (L4)	Search for NDBs		<p>NO RESULTS: No NDBs within search area or selection list including identifier, bearing, and distance to each result.</p> <p>INFO: Provides information and aids in selection.</p>
NRST USR (R3)	Search for nearest user waypoints		<p>NO RESULTS: No user waypoints within search area or selection list including identifier, bearing, and distance to each result.</p> <p>INFO: Provides information and aids in selection.</p>
NRST VOR (L3)	Search for nearest VORs		<p>NO RESULTS: No VORs within search area or selection list including identifier, bearing, and distance to each result. (Geodetic results only)</p> <p>INFO: Provides information and aids in selection.</p>
Identifier Entry Box	Area to enter identifier where encoder message would normally appear.	N/A	Entry of at least two characters and then SEARCH (R8) appears to begin immediate search. Selection list may appear

Table 5-4: Active Flight Plan Menu Options

Menu Options	Action for Active Flight Plan	Search Limits	Limitations
			<p>for addition to add to flight plan.</p> <p>INFO: Provides information and aids in selection.</p>
DELETE (R3)	<p>If highlighted waypoint is a non-procedure waypoint, deletes the waypoint after confirmation.</p>		<p>If highlighted waypoint is part of a procedure, deletes entire procedure after confirmation. Does not appear if highlighted waypoint is a non-procedure and there are fewer than three non-procedure waypoints in active flight plan.</p> <p>Does not appear if highlighted waypoint is suppressed or one position beyond the end.</p>
DIRECT (R4)	<p>Inserts phantom waypoint at the current aircraft position and makes the highlighted waypoint active.</p>		<p>Phantom waypoint is a fly-over defined entry waypoint, and leg prior to phantom waypoint is designated a discontinuity. Assures skyway is re-centered for guidance. Does not appear when highlighted waypoint is suppressed or one position beyond the end.</p>

5.8.2. Active Flight Plan (ACTV) Menu Options (Step-By-Step)

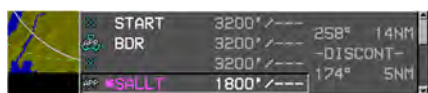

- 1) Press **ACTV (L2)** to view active flight plan.
- 2) Rotate **1** to desired waypoint. Push to enter.
- 3) Rotate **1** to desired option (for example **OFLY/AUTO..**) and push to enter.
- 4) Rotate **1** to **OVERFLY** and push to enter.
- 5) SALLT is now overflowed without published hold.

5.8.3. Active Flight Plan (ACTV) Menu (Step-By-Step)



- 1) With desired flight plan selected and activated, press **ACTV (L2)** to view active flight plan.
- 2) Rotate **1** to desired waypoint. Push to enter.
- 3) As one option, rotate **1** to **VNAV..** and push to enter a VNAV setting.
- 4) Rotate **1** to **ALTITUDE:** and push to enter. Rotate **1** to select 3000' and push to enter. Rotate **1** to **OFFSET:**, and push to enter. Rotate **1** to -1NM and push to enter.
- 5) View active flight plan with waypoint crossing altitude offset of 1 NM before at 3000'.

5.8.4. Active Flight Plan (ACTV) Leg Management (Step-By-Step)



- 1) With desired flight plan selected and activated, press **ACTV (L2)** to view active flight plan.
- 2) ATC issues clearance to proceed direct to KWR1 and maintain flight plan route.



- 3) Rotate **1** to highlight KWR1 and press **DR (R4)** and then push **1** to enter direct route to KWR1.
- 4) This action results in Highway in the Sky (HITS) guidance directly to KWR1 following the new magenta line to the new active waypoint.



- 5) In another scenario, ATC issues a radar vector to fly heading 110° to intercept flight plan route to KWR1.
- 6) Press **ACTV (L2)** and rotate **1** to KWR1 and push to enter.

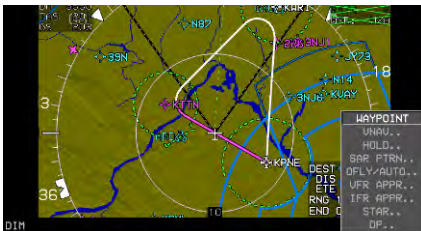

- 7) If no other action is necessary to comply with ATC clearance, with **WAYPOINT** highlighted, push **1** to make the leg between KTTN and KWR1 the active leg.



- 8) On this radar vector leg, no HITS boxes (guidance) are visible until intercepting the active leg.

5.8.5. Active Flight Plan (ACTV) NRST Menu Option (Step-By-Step)



- 1) With active flight plan displayed, press **NRST (R3)** to see NRST options.



- 2) **APT..** is at the top of the list and automatically highlighted. Push **1** to view list of 20 nearest airports (with name, bearing, and distance) within 240NM with a runway length greater than or equal to the minimum runway length setting in EFIS limits.

If no airports are found within this search criteria “NO RESULTS” message appears.

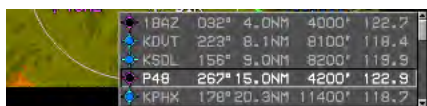

- 3) Rotate **1** to highlight desired airport information, push to send frequency to **COM1 (R2)** or **COM2 (R3)**, or push **1** to change active flight plan for direct to the highlighted airport via geodesic routing.

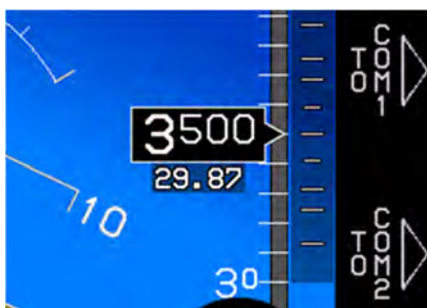



- 4) Press **NRST (R3)**. Rotate **1** to **VOR..** and push to view list of 20 nearest VORs (with bearing and distance) within 240NM.

If no VORs are found within this search criteria “NO RESULTS” message appears.

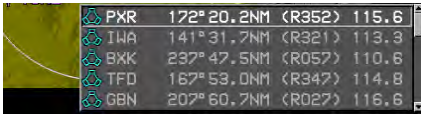

- 5) Rotate **1** to desired VOR and send frequencies to **TO NAV1 (R2)** or **TO NAV2 (R3)** or push **1** to change active flight plan for direct to the highlighted VOR via geodesic routing.



- 6) Press **NRST (R3)**. Rotate **1** to **ILS..** and push to view list of 20 nearest ILS procedures with identifier, bearing and distance within 240NM.

If no ILSs are found within this search criteria “NO RESULTS” message will appear.



- 7) Rotate **1** to desired ILS procedure and push to enter. If selection begins with “LOC” such as the last two on this list,



no action is taken when **1** is pushed. (See Section 7 IFR Procedures for details and limitations.)



- 8) Press **NRST (R3)**. Rotate **1** to **NDB..** and push to view list of 20 nearest NDBs (with identifier, bearing, and distance) within 240NM.

If no NDBs are found within this search criteria “NO RESULTS” message appears.

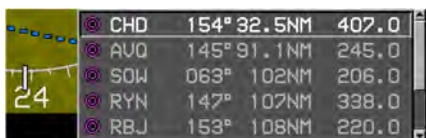

- 9) Rotate **1** to desired NDB or push **1** to change active flight plan for direct to the highlighted NDB via geodesic routing.



- 10) Press **NRST (R3)**. Rotate **1** to **FIX..** and push to view list of 20 nearest ATC fix names with identifier, bearing, and distance within 240NM.

If no fixes are found within this search criteria “NO RESULTS” message appears.

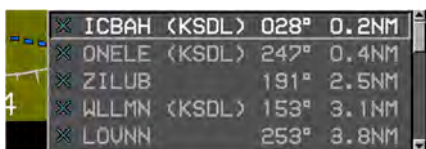

- 11) Rotate **1** to desired fix or push **1** to change active flight plan for Direct-To the highlighted fix via geodesic routing.



- 12) Press **NRST (R3)**. Rotate **1** to **USER..** and push to view list of 20 nearest user waypoint names (with identifier, bearing and distance) within 240NM.

If no user waypoints are found within this search criteria “NO RESULTS” message appears.

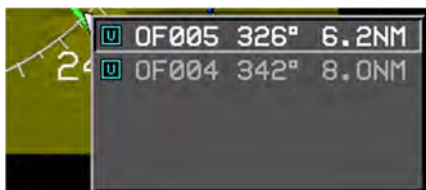

- 13) In this case, only two user waypoints were found within the search criteria. Rotate **1** to desired user waypoint or push **1** to change active flight plan for direct to the highlighted user waypoint via geodesic routing.



- 14) Press **NRST (R3)**. Rotate **1** to **ARTCC..** and push to view list of 20 nearest ARTCC frequencies waypoint names (with RX/TX capability, name, bearing, and distance,) within 240NM to the antenna site location.



If no **ARTCC** frequencies are found within this search criteria “NO RESULTS” message appears.

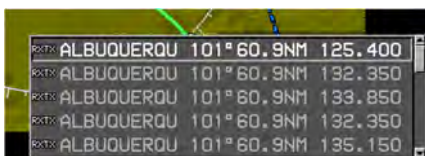

- 15) Rotate **1** to desired ARTCC frequency to desired **TO COM1 (R2)** or **TO COM2 (R3)** and push (if configured.)



- 16) Press **NRST (R3)**. Rotate **1** to **FSS..** and push to view list of 20 nearest FSS names (with RX/TX capability, name, bearing, and frequencies) within 240NM to the antenna site location.

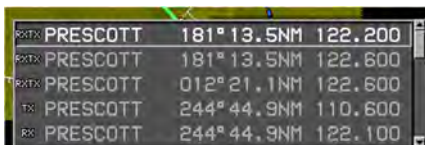

- 17) Rotate **1** to desired FSS frequency to desired **TO COM1 (R2)** or **TO COM2 (R3)** and push when configured (as in step 23).



- 18) Press **NRST (R3)**. Rotate **1** to **WX..** and push to view list of 20 nearest FSS facilities with Identifier name, bearing and distance to the airports supported by METAR and TAF weather reports with Datalink option enabled in EFIS limits.



- 19) Rotate **1** to desired airport to view airport information with weather symbology present.

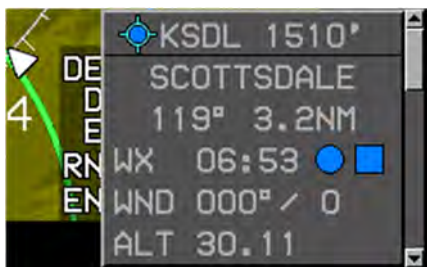

- 20) During this step, **INFO (L3)** appears, when pressed, **WX LGND (L2)** and **EXPND WX (L3)** appear for follow up information on airport weather information.

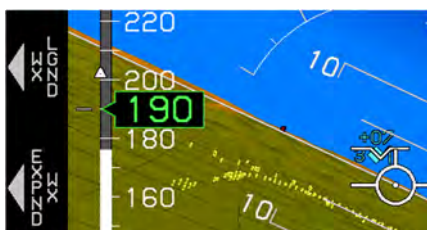

- 21) Press **WX LGND (L2)** for display of legend examples or **EXPND WX (L3)** to view expanded METAR and or TAF reports for that selected airport.



- 22) METAR and or TAF reports are found at the bottom.

5.9. Information (INFO) Menu

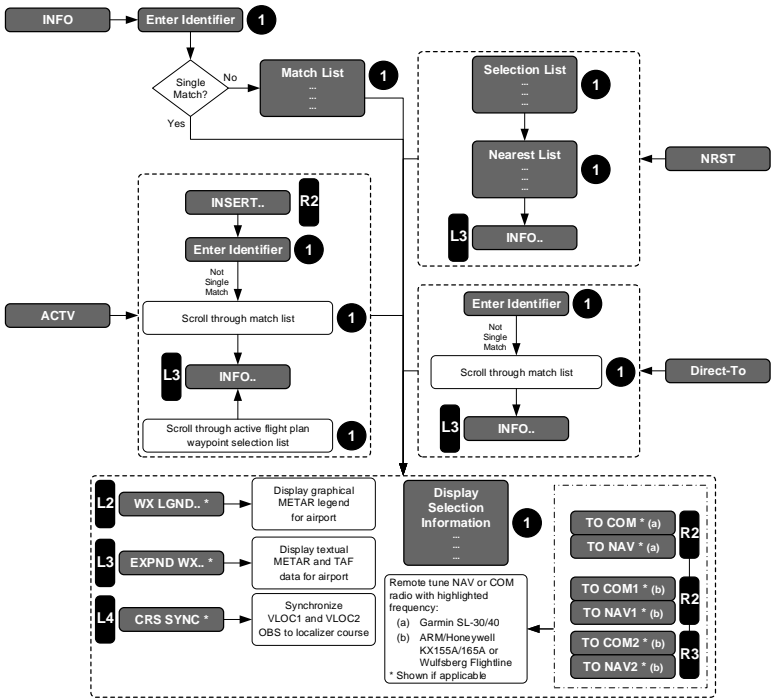

Figure 5-16: Information Menu

If **INFO** is activated from within the **ACTV**, **NRST**, or **Direct** menus, information on the highlighted waypoint is shown. Otherwise, the function checks for an active waypoint. If there is an active waypoint, it becomes the default entry. If there is no active waypoint, then the nearest airport becomes the default entry. If the default entry is accepted, then information for the default entry is shown. If the user rejects the default entry by entering identifier characters, then a search for matching characters is performed. Only two identifier characters are needed prior to searching, therefore after entering two identifier characters, **SEARCH (R4)** appears which allows an immediate search to begin if desired. If there is a single result from the search, information for that result is shown. If there is no result from the search, the user is re-prompted to enter an identifier. If there are multiple results from the search, a selection list with matching identifiers is presented to allow the user to select the desired identifier.

The amount and type of information presented depends upon the type of waypoint as in Table 5-5.

Table 5-5: INFO Menu Information

Type	NAVAID	Airports
Waypoint Identifier	NAVAID	Communication frequencies
Waypoint Type	Type	Airport runway data
Waypoint elevation	Frequency	
Long Name		
Bearing and distance		
Latitude and longitude		

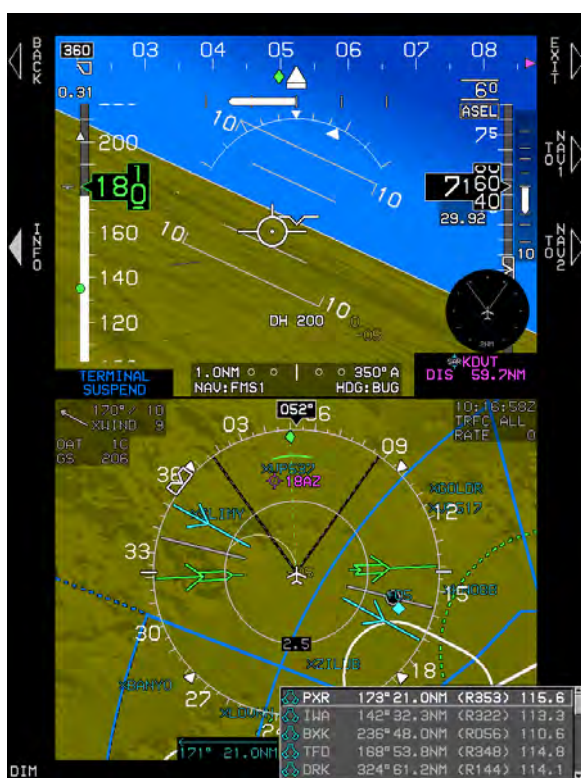

Figure 5-17: Remote Tuning NAV Radios

TO NAV1 (R2) or **TO NAV2 (R3)** is shown to allow transmission of the frequency to remote radios when frequencies less than 118 MHz are highlighted in the INFO block.



For remote tuning, **TO COM1 (R2)** and/or **TO COM2 (R3)** is shown to allow transmission of the frequency to remote radios when frequencies greater than or equal to 118 MHz are highlighted in the INFO block.

Figure 5-18: Remote Tuning COM Radios

When information presented is for an ILS or localizer waypoint and the VLOC1 or VLOC2 omnibearing selectors are not synchronized with the localizer course, **CRS SYNC (L4)** synchronizes VLOC1 and VLOC2 omnibearing selectors to the localizer course.

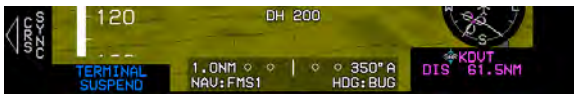

Figure 5-19: CRS SYNC

5.9.1. Information (INFO) Menu (Step-By-Step)



- 1) Press **INFO (L3)** to view active waypoint.



- 2) Push **1** to view information.



- 3) Press **WX LGND (L2)** to view examples of weather symbology or **EXPND WX (L3)** to view METARS and or TAF reports.



- 4) In this case, KEWR includes METAR and TAF reports from the optional Datalink configured in EFIS limits.

5.10. Omnibearing Selector (OBS) Menu

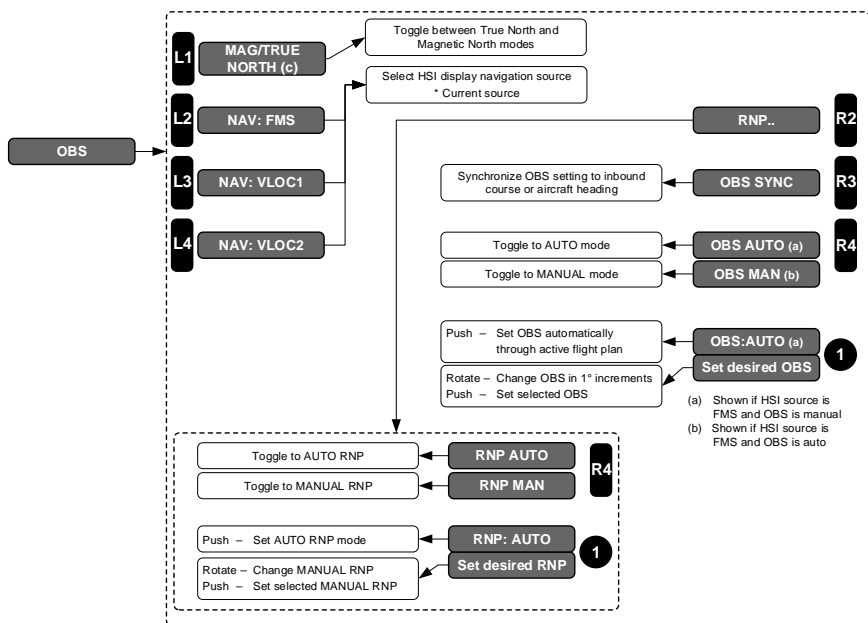









Figure 5-20: Omnibearing Selector (OBS) Menu

OBS menu allows for control of the omnibearing selector for showing course deviations. When navigation/HSI source is FMS, **OBS AUTO/OBS MAN (R4)** toggles between automatic and manual OBS settings (see Table 5-6).

NOTE:

If true north mode discrete input is not configured, the OBS menu allows the pilot to toggle between **TRUE NORTH** and **MAG NORTH** modes.

Table 5-6: Omnibearing Selector (OBS) Menu Options

OBS (L4)	OBS SYNC (R3)	OBS MANUAL (R4)	Nav Source and CDI Indication
FMS (L2) 	Only available with active waypoint. Synchronizes FMS to inbound course	Only available with active waypoint. Settable in increments of 1° with 1	GPS navigation source FMS1 or FMS2
VLOC1 (L3) 	Synchronizes VLOC1 or VOR1 to the inbound course or if the inbound course cannot be determined, to aircraft heading.	Settable in increments of 1° with 1	LOC1 VOR1 BC1
VLOC2 (L4) 	Synchronizes VLOC2 or VOR2 to the inbound course or if the inbound course cannot be determined, to aircraft heading.		LOC2 VOR2 BC2
RNP (R2) 	When selected, allows for RNP(R4)  or 	Rotate 1 to set desired manual RNP value.	Manual RNP is selectable between 0.15NM and 15NM. 0.01 increments RNP 0.10-0.3 0.1NM increments RNP 0.3-2.0 1NM increments RNP 2.0-15
TRUE NORTH (L1) 	OBS Menu allows the pilot to toggle between TRUE NORTH (L1) and MAG NORTH (L1)		

5.10.1. Omnibearing Selector (OBS) Menu (Step-By-Step)



- 1) Before pressing **OBS (L4)** to make any OBS changes, view the current setting to see **FMS1** is selected.



- 2) Press **OBS (L4)** and then make HSI source selection or change to **OBS MANUAL (R4)**. (There must be an active waypoint selected to use manual OBS.)



- 3) Indications of FMS being the source of navigation in manual OBS mode are circled in red.



- 4) To select manual RNP press **OBS (L4)**.



- 5) Press **RNP (R2)**.



- 6) Press **RNP MANUAL (R4)**.



- 7) Rotate **1** to desired FSD and push to enter to view estimate of position uncertainty required in RNP airspace.

RNP: 1.7M
ANP: 0.1

5.10.2. True North and Magnetic North Menu (Step-by-Step)



- 1) Press **OBS (L4)** to open menu for true north option selection.



- 2) Press **TRUE NORTH (L1)** to change heading reference to true instead of magnetic, or activate switch if True North discrete is enabled in EFIS limits.



- 3) Reference is now true north as seen in heading indications and **TRUE NORTH** advisory flag.

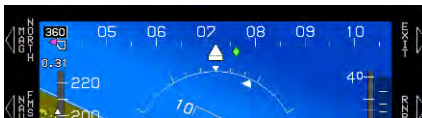

- 4) Press **MAG NORTH (L1)** to restore heading reference to magnetic north.



- 5) Heading reference is now magnetic.

5.11. Heading Bug (HDG) Menu

Use the heading bug menu to set the heading bug in increments of 1°, synchronize to current heading, or turn off heading bug.

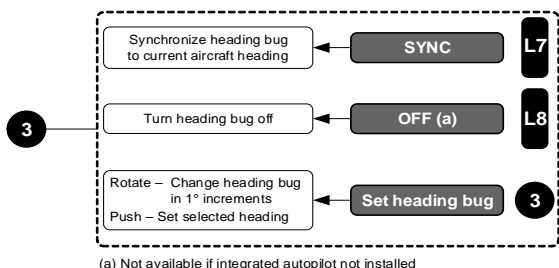

Figure 5-21: Heading Bug (HDG) Menu

5.11.1. Heading Bug (HDG) Menu (Step-By-Step)



- 1) Rotate **3** to enter heading mode.



- 2) Rotate **3** to change heading bug in 1° increments. In this example, the EFIS is in LNAV arm mode, and the HDG bug is hollow to indicate it is in preset sub-mode and not providing left-right steering commands to the autopilot.



- 3) Push **3** to select new heading or press **SYNC (L7)** to synchronize current heading.





- 4) To change the HDG sub-mode to HDG, press **HDG (L5)** and the autopilot begins receiving left-right steering commands from the filled HDG bug.



- 5) HDG bug sub-mode is now HDG BUG and **LNAV (L5)** appears for one touch changing back to LNAV sub-mode. HDG bug is filled in on the heading tape and Map page.

5.12. Altitude Bug (ASEL) Menu

Use the altitude bug menu to synchronize the target altitude to current altitude, turn off the target altitude, or set the target altitude in increments of 100 feet.

NOTE:

“Target Altitude” refers to pre-selected altitude in Genesys/S-TEC DFCS installations.

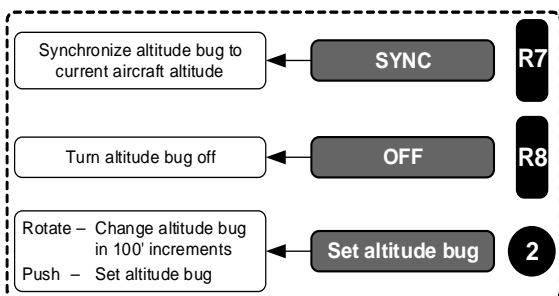

Figure 5-22: Altitude Bug (ASEL) Menu

5.12.1. Altitude Bug (ASEL) Menu (Step-By-Step)



- 1) Rotate **3** to enter heading mode or push to synchronize current altitude to ASEL.



- 2) Press **SYNC (R7)** to synchronize current altitude or press **OFF (R8)** to turn off ASEL selection.



- 3) When ASEL has been selected, it appears in the PFI area as shown in red circles.

5.13. Nearest (NRST) Menu

Upon selecting a category from the option list, a list of up to 20 items within 240NM matching the category appears. If the list is empty (i.e., no items within 240NM), **NO RESULTS** is displayed. The selection list includes identifier, bearing, and distance to the item. The list of airports contains only airports with runway length greater than or equal to the minimum runway length setting as configured during installation.

The list for airports, VORs, ILSs, NDBs, ARTCCs, and FSSs includes an associated frequency (CTAF for airports). Tiles allow transmission of the associated frequency to remote NAV or COM radios. If the frequency is greater than or equal to 118 MHz, tiles read to either **TO COM1 (R2)** or **TO COM2 (R3)**. If the frequency is less than 118 MHz, tiles read **TO NAV1 (R2)** or **TO NAV2 (R3)**.

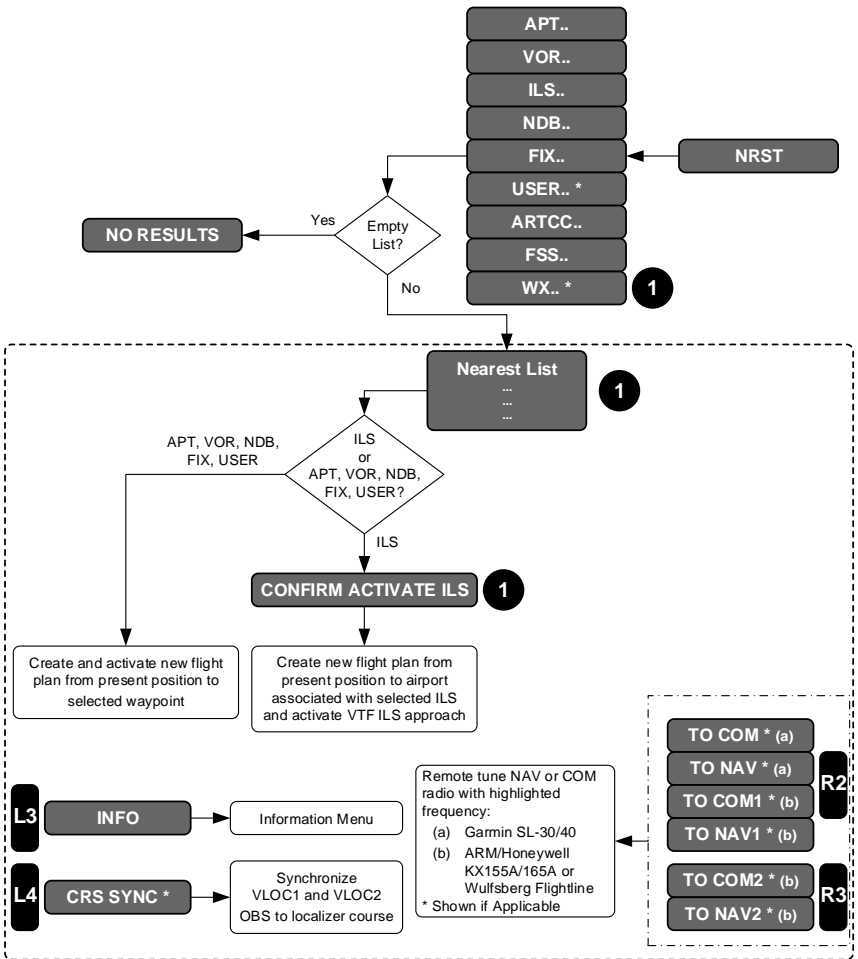

Figure 5-23: Nearest (NRST) Menu

When the results for the nearest category of airports, VORs, ILSs, NDBs, fixes, user waypoints, ARTCC, and FSS, are displayed, **INSERT (R2)** inserts a waypoint into the active flight plan at the active waypoint position. This feature facilitates rapid clearance changes from air traffic control. To

prevent corruption of IFR approaches, STARs, and DP, **INSERT (R2)** does not appear if the active waypoint is within a procedure.

When the results for airports, VORs, ILSs, NDBs, fixes, and user waypoints are displayed, **INFO (L3)** provides further information on the highlighted item.

In the case of **NRST ILS** where the current VLOC1 or VLOC2 OBS does not match the localizer course, **CRS SYNC (L4)** synchronizes VLOC1 and VLOC2 OBS to the localizer course.

Upon selecting airport, VOR, NDB, fix, or user waypoint, a new active flight plan is created from present aircraft position to the selected waypoint. Upon selecting ILS, **CONFIRM ACTIVATE ILS** is displayed. When the ILS is confirmed, the following actions occur:

- 1) A direct flight plan to the airport associated with the ILS is created;
- 2) A vectors-to-final ILS approach to the ILS is activated;
- 3) If the heading bug is turned off, it is activated to current heading to act as a starting point for receiving vectors (AP enabled systems only);
- 4) VLOC1 and VLOC2 OBS settings are set to the associated localizer course;
- 5) HSI source is switched as follows:
 - a) If only one NAV radio is installed, the source for the selecting side is changed to VLOC1 in preselect. The source for the other side does not change.
 - b) If dual Nav sources are installed, the default sensor for the selecting side controls which source is used. Source for the other side does not change.
- 6) Connected NAV radios are remote tuned to ILS frequency in the preselected position.

5.13.1. Nearest (NRST) Menu (Step-By-Step)

(See step-by-step procedures for ACTV NRST menu option § 5.8.5)



- 1) Press **NRST (R3)** to enter nearest menu.
- 2) Rotate **1** to select **APT..** and push to enter.



- 3) Rotate **1** to desired airport and select **TO COM1 (R2)**, **TO COM2 (R3)**, **INFO (L3)**, or push **1** to change active waypoint to desired airport.



- 4) If a nav frequency is selected, press **TO NAV1 (R2)** or **TO NAV2 (R3)** to send frequency, or push **1** to change active waypoint to selected VOR.

NOTE:

TO NAV1 and **TO NAV2** only appear if this auto-tuning feature is enabled in the EFIS.

5.14. Direct Menu

Upon activating the direct menu from the top-level menu, if an active waypoint is found, it is the default entry. If there is no active waypoint, the nearest airport is the default entry.

If the default entry is the active waypoint and accepted by the pilot, a phantom waypoint is inserted at the current aircraft location. The phantom

waypoint is a fly-over defined entry waypoint, and the leg prior to the phantom waypoint is designated a discontinuity. This assures the skyway is re-centered to provide guidance to the new active waypoint. The rest of the active flight plan remains unchanged.

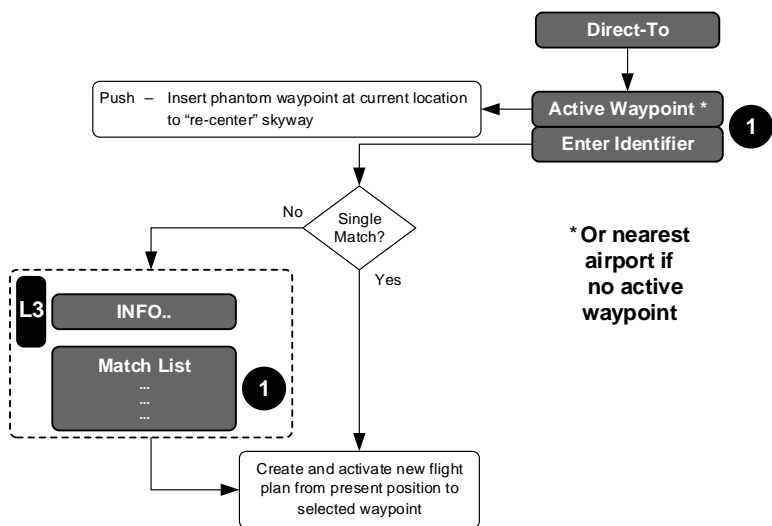

Figure 5-24: Direct Menu

If the default entry is not the active waypoint and accepted by the pilot, the resulting action depends upon whether the aircraft is in the air or on the ground. If in the air, a new active flight plan is created from present aircraft position to the selected waypoint. If on the ground, a search is conducted for a database airport within 6NM. If an airport is found, a new active flight plan is created from the found airport to the selected waypoint. Otherwise, a new active flight plan is created from present aircraft position to the selected waypoint.

If the pilot rejects the default entry by entering identifier characters, a search for matching identifiers is performed. If there is a single result, the resulting action depends upon whether the aircraft is in the air or on the ground. If in the air, a new active flight plan is created from present aircraft position to the selected waypoint. If on the ground, a search is conducted for a database airport within 6NM. If an airport is found, a new active flight plan is created from the found airport to the selected waypoint. Otherwise, a new active flight plan is created from present aircraft position to the selected waypoint.

If there is no result, pilot is re-prompted to enter an identifier. If there are multiple results, a selection list with matching identifiers is presented. Upon selection, the resulting action depends upon whether the aircraft is in the

air or on the ground. If in the air, a new active flight plan is created from present aircraft position to the selected waypoint. If on the ground, a search is conducted for a database airport within 6NM. If an airport is found, a new active flight plan is created from the found airport to the selected waypoint. Otherwise, a new active flight plan is created from present aircraft position to the selected waypoint. **INFO (L3)** gives information for the highlighted result.

5.14.1. Direct Menu (Step-By-Step)

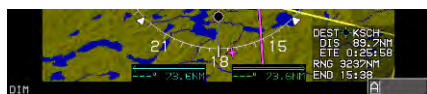
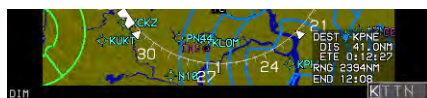

- 1) Press **➔ (R4)** to enter direct menu.
- 2) Active or nearest airport waypoint appears. In this scenario, the active waypoint is KTTN.
- 3) Rotate **1** to create a new waypoint, followed by pushing/rotating to step through all five character spaces.
- 4) After creating new identifier, rotate **1** to the end and push to enter and create a new active flight plan from the present aircraft position. If there is more than one option for the created waypoint, scroll through the list by rotating **1** and then push to enter.

5.15. Time Menu

Upon selecting the time menu, a list appears to choose **COUNT UP..** timer, **COUNT DN..** timer, **UTC OFFSET..**, or **FLT TIME** display. **OFF (R4)** turns off any active timer functions.

If the pilot selects the count up timer, the count up timer is activated. If the countdown timer is selected, the pilot is prompted to enter a start time from which the countdown begins. Shortcut buttons to quickly add or decrease by five-minute increments. After entering a start time, start the countdown timer or press **STORE (R4)** or push **1** to store the start time for later use.

If UTC offset is selected, the pilot is prompted to enter a UTC offset between -12:00 and +14:00 in 15-minute increments.

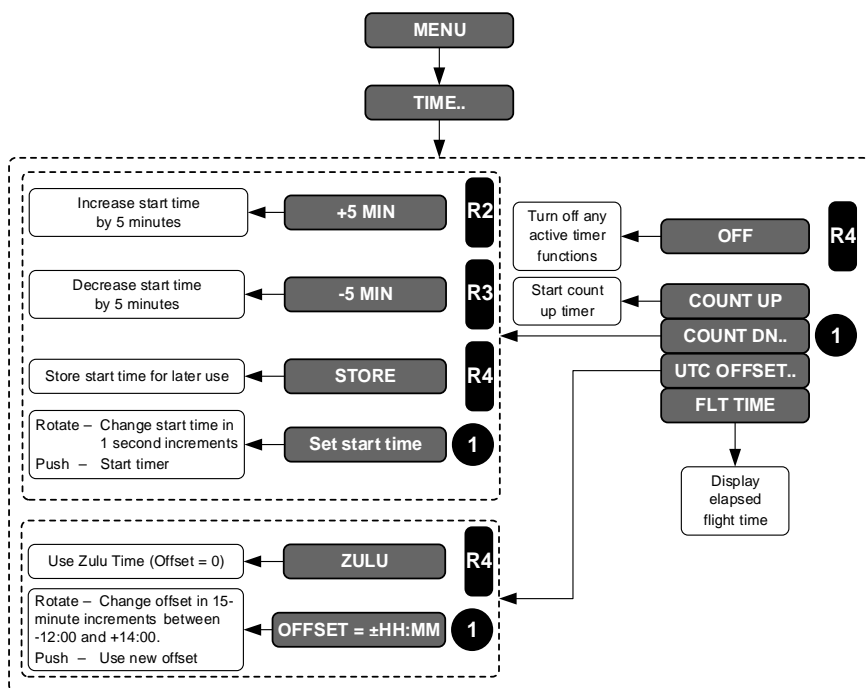
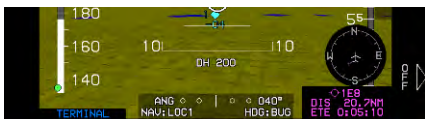

Figure 5-25: Time Menu

If the pilot selects the flight time display option, the elapsed time since the aircraft transitioned from ground to air mode is displayed for 10 seconds or until any button is pressed. If the aircraft has not yet transitioned from ground to air mode, upon selecting the flight time display option, elapsed time is displayed as **FLT TM: 00:00:00**.

5.15.1. Time Menu (Step-By-Step)



- 1) Press **MENU (R1)**.
- 2) Press **TIME (L4)** to enter time menu
- 3) Rotate **1** to **COUNT UP**, **COUNT DN..**, **UTC OFFSET..**, or **FLT TIME**. Push to enter.
- 4) If **COUNT UP** is selected, a timer appears on the PFI below bank scale.



5) To turn off timer, press **MENU (R1)**, **TIME (L4)**, then **OFF (R4)**.

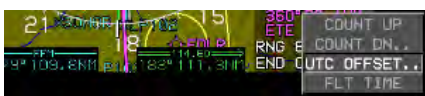

6) To set offset for local time, rotate **1** to **UTC OFFSET...** Push to enter.



7) Rotate **1** to desired offset value. Push to enter.



8) Local time now appears where Zulu time was previously.

5.16. PFD Source Menu

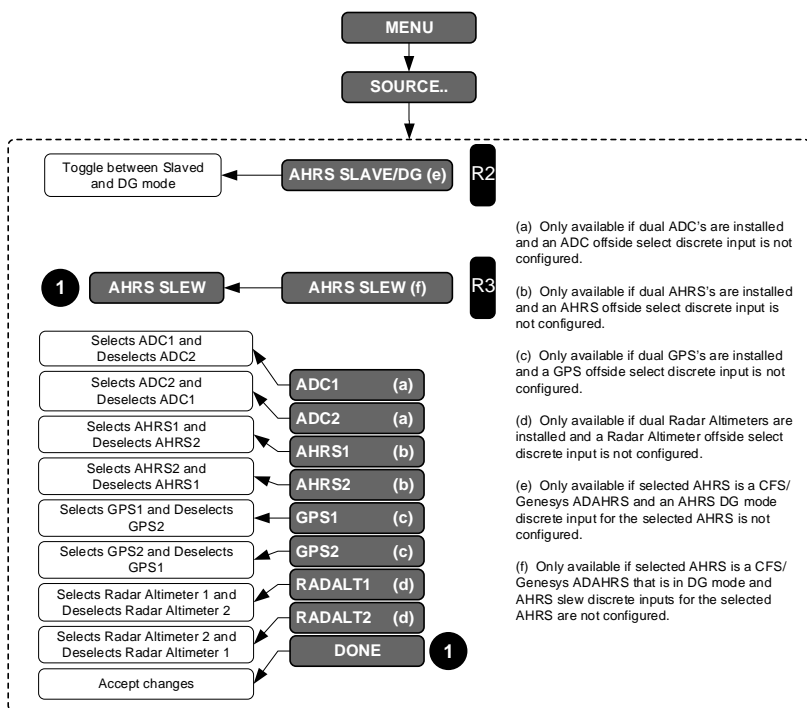

Figure 5-26: PFD Source Menu

Upon activating the PFD source menu, an option list of sensor sources appears to select/deselect the following items if external switches are not configured through discrete input configuration:

- | | |
|----------|----------------------|
| 1) ADC1 | 5) GPS1 |
| 2) ADC2 | 6) GPS2 |
| 3) AHRS1 | 7) Radar Altimeter 1 |
| 4) AHRS2 | 8) Radar Altimeter 2 |



AHRS SLAVE/AHRS DG (R2) toggles between the two AHRS modes. **AHRS SLEW (R3)** enters a submenu to adjust the DG mode slewing value (if a DG/Slave discrete input is not configured for that AHRS.) When Genesys AHRS is installed and in DG mode without discrete inputs for the selected AHRS are not selected.

Figure 5-27: AHRS SLAVE/AHRS SLEW

5.16.1. PFD Page First-Level Source Selection (Step-By-Step)

When dual sensors are installed with an ADC, AHRS, and GPS off-side select discrete is not configured.



- 1) Press **MENU (R1)**.



- 2) Press **SOURCE (L2)**.



- 3) Rotate **1** to check desired source, push to check, rotate to **DONE**, and push to enter or press **EXIT (R1)**.

5.17. PFD Bugs (BUGS) Menu

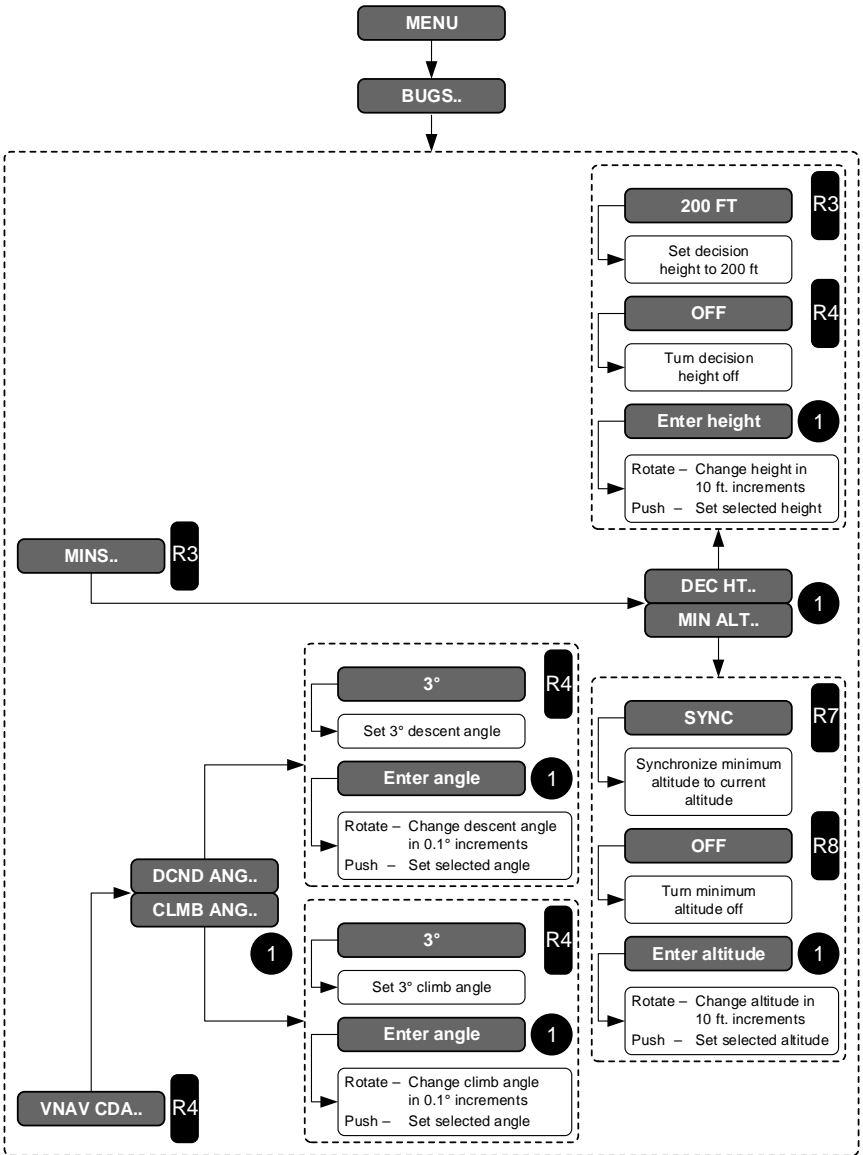

Figure 5-28: PFD Bugs (BUGS) Menu

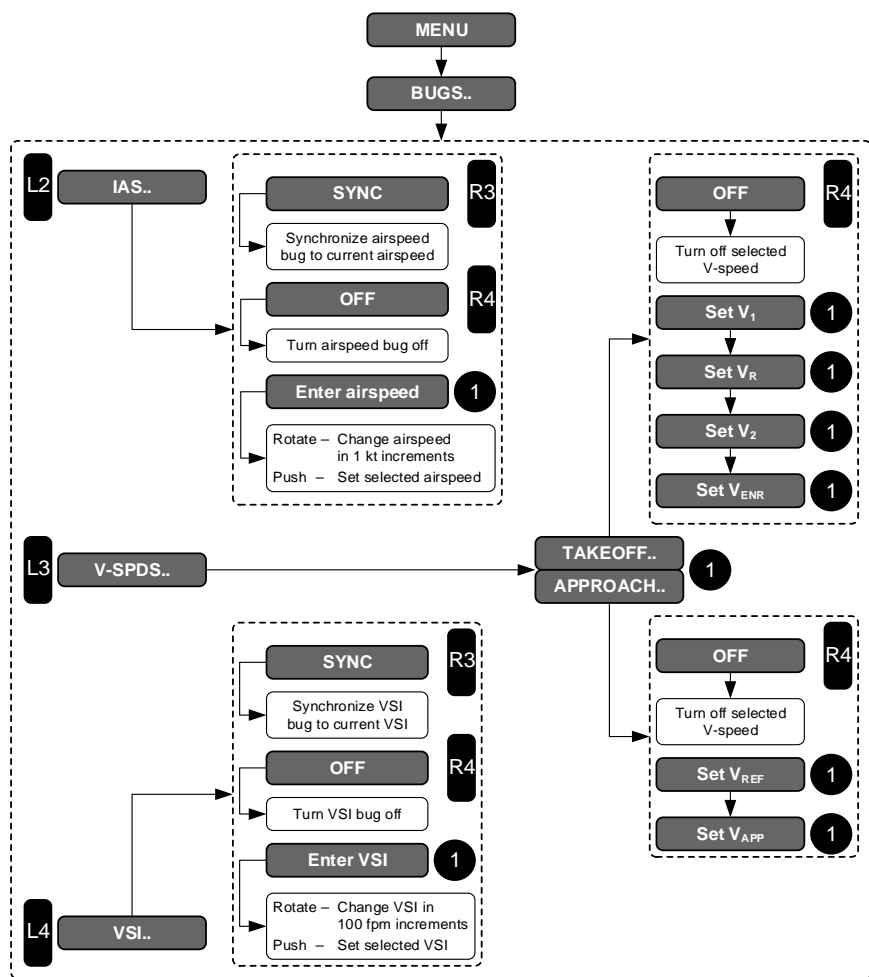

Figure 5-29: PFD Bugs (BUGS) Menu (Continued)

Upon selecting the PFD bugs menu, choose from the following:

- 1) **MINS (R3)**: Push **1** to select **DEC HT..** then **200 FT (R3)** or **OFF (R4)**, or set DH in increments of 10' or;

Rotate **1** to select **MIN ALT..**, press **SYNC (R3)** to synchronize minimums to current altitude or rotate **1** to desired minimum altitude in increments of 10';
- 2) **IAS (L2)**: Set airspeed bug to synchronize with current airspeed, turn off, or set the bug in increments of 1 knot IAS). (No bug setting less than 1.2 V_S or 60 KIAS, whichever is lower. No higher than V_{MO}/M_{MO});

- 3) **VNAV CDA (R4)**: Set VNAV climb or descent angle (setting either in increments of 0.1° with corresponding feet per nautical mile, or selecting a shortcut for **3° (R4)**);
- 4) **V-SPDS (L3)**: Set V-speeds options for either takeoff V-speed (**V₁**, **V_R**, **V₂**, and **V_{ENR}**) or approach V-speeds (**V_{REF}** and **V_{APP}**) or;
- 5) **VSI (L4)**: Set vertical speed by synchronizing the VSI bug to the current VSI, turning off the VSI bug, or setting the VSI bug in increments of 100 feet per minute.

NOTE:

With the exception of when integrated with a Genesys/S-TEC DFCS, the airspeed bug and VSI bug are mutually exclusive and therefore selecting one turns off the other.

5.17.1. PFD Bug (BUGS) Menu (Step-By-Step)



- 1) Press **MENU (R1)** and then **BUGS (R2)** to enter the bugs menu.



- 2) Press **IAS (L2)**, **V-SPDS (L3)**, **VSI (L4)**, **MINS (R3)**, or **VNAV CDA (R4)**.



- 3) If IAS is pressed, press **SYNC (R3)** to accept or **OFF (R4)** to turn off IAS bug. (If integrated with Genesys/S-TEC DFCS in IAS mode, it is not possible to turn off the airspeed bug.)



- 4) Press **VSI (L4)** to adjust VSI bug. Rotate **1** to set in increments of 100 fpm and push to enter. (If integrated with Genesys/S-TEC DFCS in VS mode, it is not possible to turn off the VSI bug.)



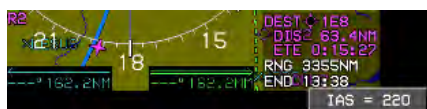

- 5) For a different IAS bug, rotate **1** to select airspeed. Push to enter new value. Value is displayed in PFI area above airspeed tape.



- 6) If **MINS (R3)** is pressed, rotate **1** to select **DEC HT..** or **MIN ALT..** and push to enter.

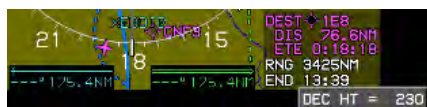

- 7) If **DEC HT..** is pushed, rotate **1** to create new decision height and push to enter.



- 8) New DH displays on the PFI area below the FPM.



- 9) If **VNAV CDA (R4)** is pressed, rotate **1** to select **DCND..** or **CLIMB...** Push to enter.

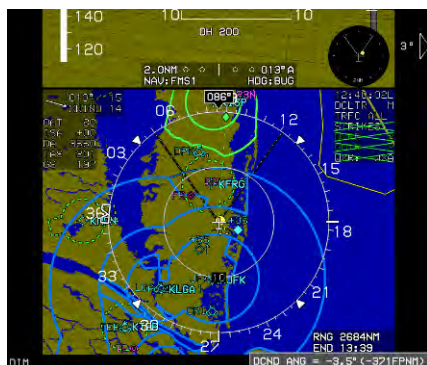

- 10) If **DCND..** is pressed, rotate **1** to create new descent angle.
- 11) For example, select **-3.5° (-371 FPNM)**. Push **1** or press **EXIT (R1)** to enter.

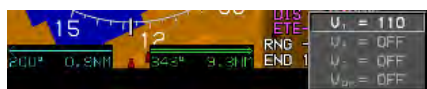

- 12) For V-speeds, press **V-SPDS (L3)**. Rotate **1** to **TAKEOFF..** and push to enter.



- 13) Rotate **1** to desired **V₁** speed and push to enter.



- 14) Rotate **1** to desired **V_R** speed and push to enter.



15) Rotate **1** to desired V_2 speed and push to enter.



16) Rotate **1** to desired V_{ENR} speed and push to enter. Normally, takeoff speeds are set in sequence. This example shows V_1 , V_R , and V_2 turned off.



17) To set approach bugs, press **V-SPDS (L3)** and rotate **1** to **APPROACH..** and push to enter.



18) Rotate **1** to desired V_{REF} speed and push to enter.



19) Rotate **1** to desired V_{APP} speed and push to enter.

5.18. PFD Declutter (DCLTR) Menu

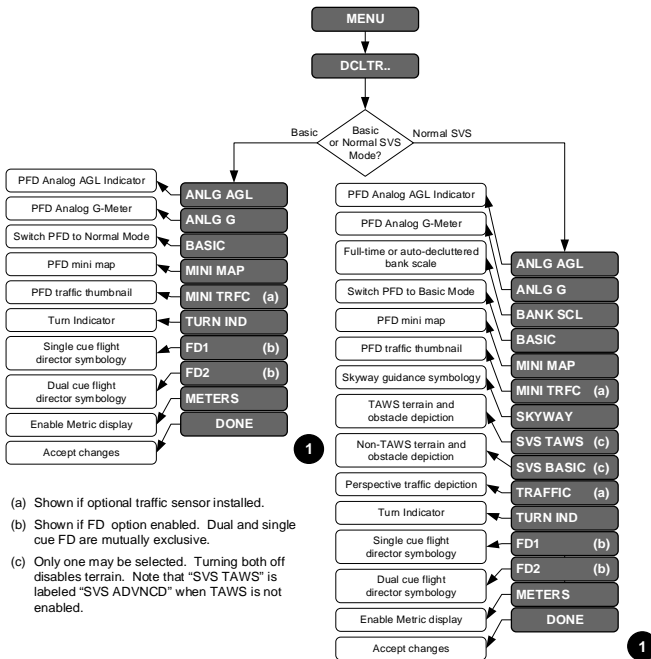

Figure 5-30: PFD Declutter (DCLTR) Menu

Upon activation of the PFD declutter menu, an option list of declutter items are shown.

Table 5-7: PFD Declutter Options

Option	Configuration		Notes
	Normal SVS	Basic	
ANLG AGL	✓	✓	Mutually exclusive
ANLG G	✓	✓	
MINI MAP	✓	✓	
MINI TRFC	✓	✓	
BANK SCL	✓		
BASIC	✓	✓	Always in view while in basic mode
SKYWAY	✓		
SVS TAWS	✓		SVS TAWS is labeled "SVS ADVNCD" when TAWS is not enabled
SVS BASIC	✓		
TRAFFIC	✓		Perspective Traffic indications
TURN IND	✓	✓	
FD1	✓	✓	Mutually exclusive
FD2	✓	✓	
METERS	✓	✓	Additional metric display of altitude, target altitude, and bug setting

5.18.1. PFD Declutter (DCLTR) Menu (Step-By-Step)

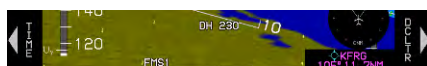

- 1) Press **MENU (R1)** and then **DCLTR (R4)** to enter the declutter menu.
- 2) Rotate **1** to **ANLG AGL**, **ANLG G**, **BANK SCL**, **BASIC**, **MINI MAP**, **MINI TRFC**, **SKYWAY**, **SVS TAWS**, **SVS BASIC**, **TRAFFIC**, **TURN IND**, **FD1**, **FD2**, or **METERS**. Push to enter.



- 3) If **BANK_SCL** is unchecked, press **EXIT (R1)** or rotate **1** to **DONE** and push to enter.



- 4) Bank scale is removed while in level flight.

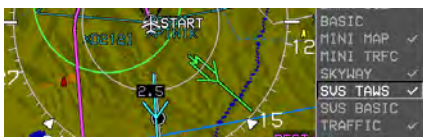

- 5) Press **MENU (R1)** and **DCLTR (R4)**. Rotate **1** to **SVS TAWS** and push to deselect.



- 6) Press **MENU (R1)** and **DCLTR (R4)**. Rotate **1** to **SVS BASIC** and push to select for display.



- 7) If a G-force telltale that can be cleared is shown, **RESET G (L2)** appears for resetting.

NOTE:

When integrated with the Genesys/S-TEC DFCS, it is only possible to toggle between the single cue and dual cue FD options. It is not possible to turn them both OFF due to control through the DFCS mode control panel.

5.19. Altimeter Menu

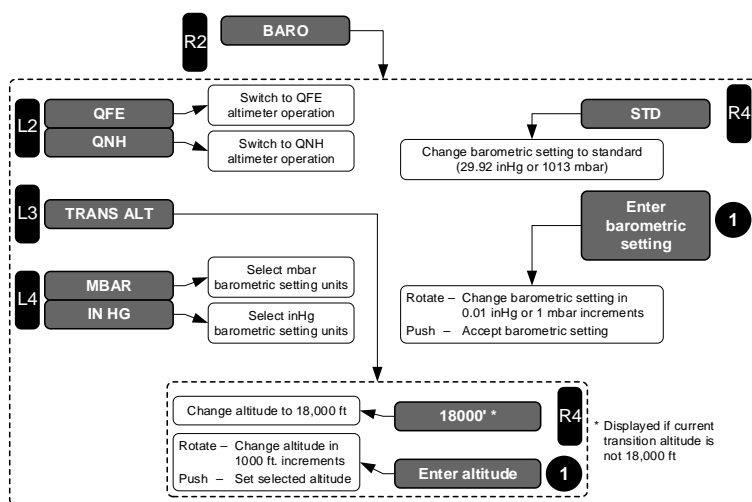

Figure 5-31: Altimeter Menu

Press **BARO (R2)** to activate the altimeter menu. Rotate **1** to increase (CW) or decrease (CCW) the barometric setting and push to accept the new barometric setting. In addition, the following options are available in the altimeter menu:

- 1) **QNH/QFE (L2):** Toggles between QNH and QFE altimeter operation. When in QNH mode, QNE operation is automatically selected when above the transition altitude with a standard altimeter setting. The following definitions:
 - a) **QFE:** Barometric setting resulting in the altimeter displaying height above a reference elevation (e.g., airport or runway threshold). If Baro-Auto-Setting is enabled in EFIS limits, when in QFE mode of operation, the EFIS autosets the altimeter to read zero altitude during a ground start.
 - b) **QNE:** Standard barometric setting (29.92 inHg or 1013 mbar) used to display pressure altitude for flight above the transition altitude.
 - c) **QNH:** Barometric setting resulting in the altimeter displaying altitude above mean sea level at the reporting station.
- 2) **TRANS ALT (L3):** Changes transition altitude in units of 500 feet. Transition altitude is used to generate barometric setting warnings and to determine QNE/QNH operation. If current transition altitude is not 18,000 feet, **18000' (R4)** sets the transition altitude as 18,000 feet.

- 3) **MBAR/IN HG (L4)**: Sets barometric setting units (inHg or mbar).
- 4) **STD (R4)**: Sets barometric setting to standard (29.92 inHg or 1013 mbar).

5.19.1. PFD Altimeter Menu (Step-By-Step)

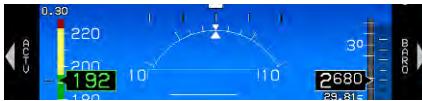

- 1) Press **BARO (R2)** to enter altimeter menu.



- 2) Rotate **1** to set proper QNH and push to enter.
- 3) Crosscheck proper QNH under altitude indication.
- 4) Press **BARO (R2)** again and **STD (R4)** to reset QNH to 1013 mbar (or 29.92 inHg). Push **1** to enter.

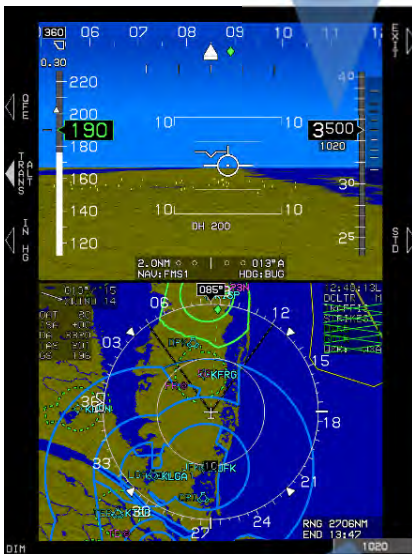

1020

5.20. Fault Display (FAULTS) Menu

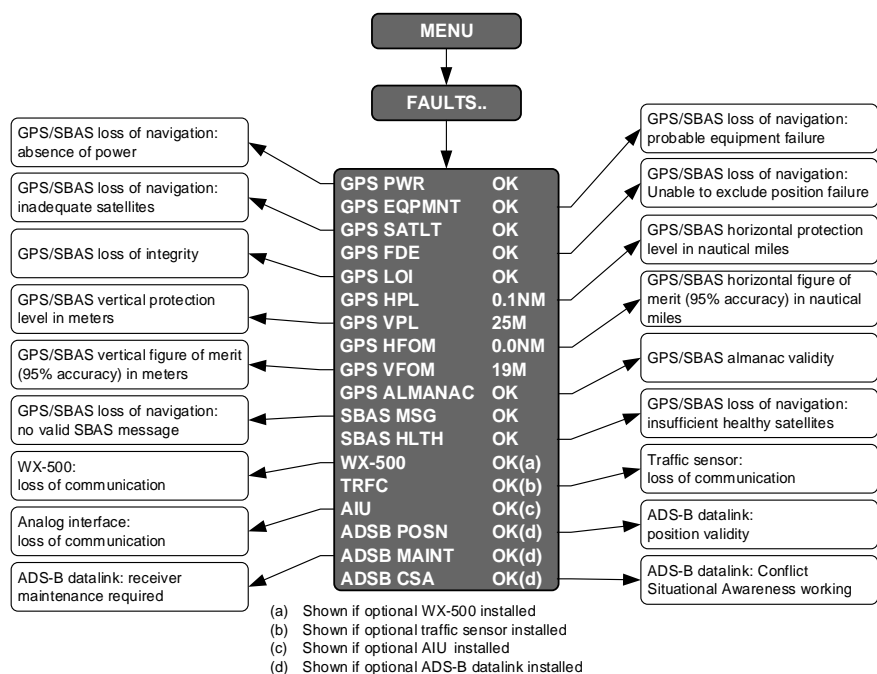

Figure 5-32: MFD Fault Display Menu

Upon selecting the MFD faults menu, status of the following system parameters are displayed.

- 1) GPS/SBAS loss of navigation due to absence of power (GPS PWR).
- 2) GPS/SBAS loss of navigation due to probable equipment failure (GPS EQPMNT).
- 3) GPS/SBAS loss of navigation due to inadequate satellites to compute a position solution (GPS SATLT).
- 4) GPS/SBAS loss of navigation due to a position failure that cannot be excluded within the time to alert (GPS FDE).
- 5) GPS/SBAS loss of integrity and loss of navigation due to loss of integrity (GPS LOI).
- 6) Readout of the current GPS/SBAS horizontal protection level (GPS HPL) in nautical miles. This value may be used as the estimate of position uncertainty required in RNP airspace.

- 7) Readout of the current GPS/SBAS vertical protection level (GPS VPL) in meters.
- 8) Readout of the current GPS/SBAS horizontal figure of merit (GPS HFOM) in nautical miles. This value is an indication of the 95% confidence horizontal position accuracy.
- 9) Readout of the current GPS/SBAS vertical figure of merit (GPS VFOM) in meters. This value is an indication of the 95% confidence vertical position accuracy. (For Example, the MSL altitude used in the TAWS algorithms use geodetic height converted to MSL with the current EGM (Earth Gravity Model) database. For this to be considered valid for use as MSL altitude, the VFOM must be less than or equal to 106 feet.) Additionally, the tertiary source for vertical speed is GPS/SBAS vertical speed providing the VFOM is less than or equal to 106 feet. When AGL altitude is based on BARO, it is because the RADALT was in a failed state (if so equipped) and the VFOM exceeded 106 feet rendering the vertical component of GPS altitude invalid in the MSL altitude calculation.
- 10) An indication of whether the GPS/SBAS receiver has a valid almanac in memory (GPS ALMANAC).
- 11) GPS/SBAS loss of navigation due to no valid SBAS message received for 4 seconds or more (SBAS MSG).
- 12) GPS/SBAS loss of navigation due to insufficient number of SBAS HEALTHY satellites (SBAS HLTH).
 - a) An attitude or range fault condition exists.
 - b) A control fault condition exists.
 - c) A T/R fault condition exists.
- 13) If the analog interface option is enabled, loss of communications with the analog interface (AIU).
- 14) If ADS-B datalink is enabled, an indication of ADS-B position validity (ADSB POSN), an indication of whether maintenance of the ADS-B receiver is required (ADSB MAINT) and an indication of whether the conflict situational awareness algorithm is working (ADSB CSA).

5.20.1. Fault Display (FAULTS) Menu (Step-By-Step)



- 1) Press **MENU (R1)** and then **FAULTS (L5)** (PFD) or **FAULTS (L1)** (MFD) to view the faults menu.
- 2) View status of GPS and equipment parameters.

5.21. Fuel Totalizer Quantity Setting (SET FUEL) Menu

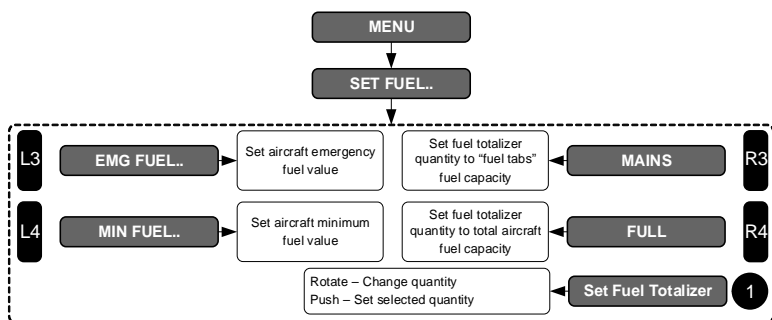
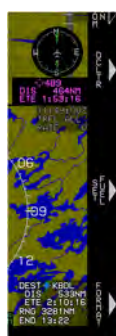
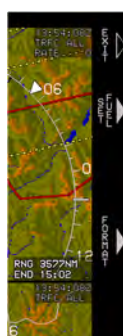

Figure 5-33: Fuel Totalizer Quantity Menu



PFD

SET FUEL (R6)



MFD

SET FUEL (R2)

Figure 5-34: PFD/MFD SET FUEL

SET FUEL menu allows the pilot to:

- 1) Set the fuel totalizer quantity in increments of volume units.

If either a fuel totalizer or fuel level sensing (with no unmonitored fuel) is configured in aircraft limits, set emergency and minimum fuel bugs in increments of volume units.

- 2) Press **MAINS (R3)** to set the quantity to the “fuel tabs” fuel capacity. Press **FULL (R4)** to set the quantity to the total aircraft fuel capacity. Units of measure and fuel flow are shown in the quantity window when available. If fuel flow is available, current fuel flow is shown on the Nav Log top area.
- 3) If an aircraft fuel caution or aircraft fuel warning is configured in the limits, set **EMG (L3)** and **MIN FUEL (L4)** fuel bugs in increments of volume units.



Figure 5-35: Fuel Totalizer Quantity Setting (SET FUEL) Menu

5.22. MFD Page Menu

- 1) **MAP**: ND page
- 2) **HSI**: HSI page
- 3) **NAV LOG**: FMS page
- 4) **STRIKES**: WX-500 Lightning Strikes page (See Strikes appendix)
- 5) **TRAFFIC**: Traffic page (See Traffic appendix)
- 6) **DATALINK**: Datalink page (See Datalink appendix)
- 7) **WX-RDR**: Weather Radar page (See Weather Radar appendix)

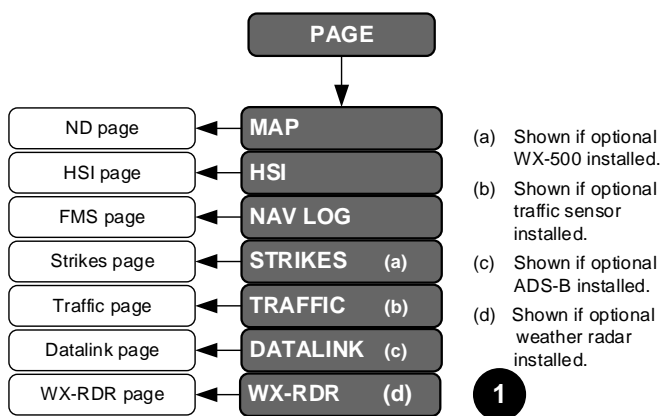
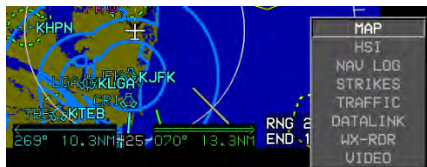

Figure 5-36: MFD Page (PAGE) Menu

5.22.1. MFD Page Menu (Step-By-Step)



- 1) Push **TOP (2)** or **BTM (1)** to change MFD pages.
- 2) If **BTM (1)**, rotate to **MAP, HSI, NAV LOG, STRIKES, TRAFFIC, DATALINK, WX-RDR** or **VIDEO**. Push to enter.



- 3) If **TOP (2)**, rotate to **MAP, HSI, NAV LOG, STRIKES, TRAFFIC, DATALINK, WX-RDR or VIDEO**. Push to enter.

5.22.2. MFD NAV LOG Page (Step-By-Step)

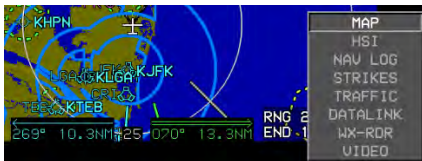

- 1) Push **TOP (2)** or **BTM (1)** and rotate to **NAV LOG**. Push to enter.

WAYPOINT	UNAV/OFFSET	PATH	DIST	ETE	ETA	FUEL
KCNO		E-198*	20.9m	0:05	14:00	3709
KSGM		E-288*	10.2m	0:26	14:26	3527
KSBA		E-317*	20.3m	0:50	15:26	3329
KSJC		D-320*	19.7m	0:04	15:32	3565
KHWD		E-244*	10.9m	0:02	15:35	3355
SFO		E-342*	18.3m	0:04	15:39	3334
REBAS		E-342*	11.3m	0:02	15:42	3322
SGD		E-114*	9.4m	0:02	15:44	3312
CROIT		E-082*	7.0m	0:01	15:46	3305
CCR		E-071*	7.3m	0:01	15:46	3297
PITTS		E-074*	10.4m	0:02	15:51	3286
DAKEY		E-074*	16.8m	0:04	15:55	3269
LDDI						

- 2) Example shown is on MFD with NAV LOG in bottom area.

5.23. MFD HSI Page (Step-By-Step)

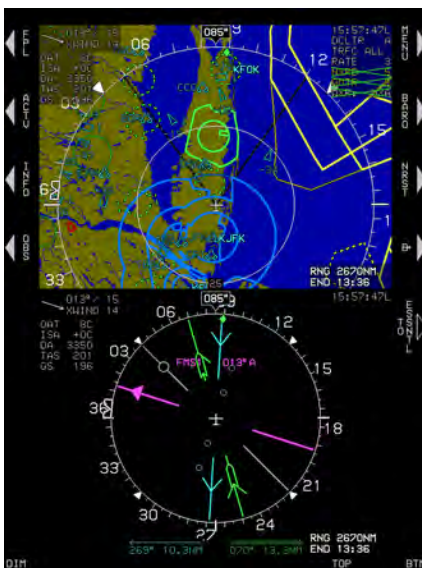

- 1) Push **TOP (2)** or **BTM (1)** and rotate to **HSI** and push to enter.
- 2) Example shown is on MFD with HSI on bottom area.

5.23.1. MFD HSI Declutter (DCLTR) Menu

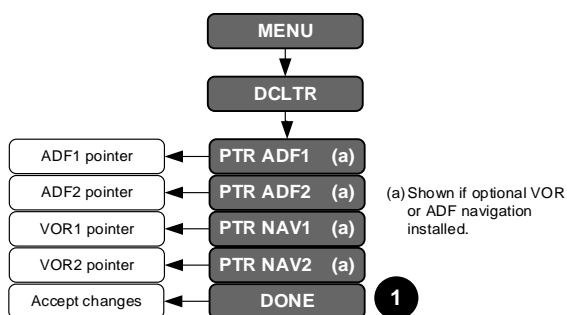
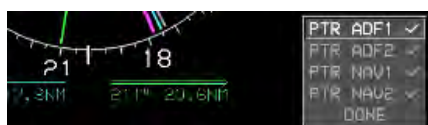
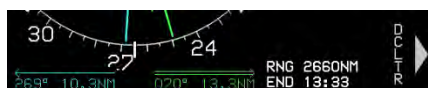
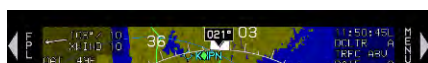

Figure 5-37: MFD HSI DCLTR Menu

Upon selecting the HSI declutter menu on the HSI page, a list appears to individually display:

- 1) ADF1 pointer (if ADF symbology if enabled);
- 2) ADF2 pointer (if dual ADF symbology if enabled);
- 3) VOR1 pointer (if VOR symbology if enabled); and
- 4) VOR2 pointer (if dual VOR symbology if enabled).

5.23.1.1. MFD HSI Declutter (DCLTR) Menu (Step-By-Step)



- 1) Press **MENU (R1)** and then **DCLTR (R4) or (R8)** to enter Declutter menu.
- 2) Rotate **1** to **PTR ADF1**, **PTR ADF2**, **NAV1**, or **PTR NAV2** and push to place check mark, then press **EXIT (R1)** or rotate to **DONE** and push to enter.

5.24. MFD Page Format Menu

Upon selecting the MFD format menu, a list appears with the following options:

- 1) **CENTER/ARC**: Toggles between centered and arced ND display format (if not panning).

- 2) **HDG UP/N UP**: Toggles between heading up and north-up display format (if not panning).
- 3) **PAN ON/PAN OFF**: Toggles page pan mode.
- 4) **SYMB DCLTR**: Activates a list to choose automatic or manual navigation symbol declutter. If the pilot chooses manual navigation symbol declutter, a list appears to individually select:
 - a) large airports;
 - b) IFR airports;
 - c) VFR airports;
 - d) VORs;
 - e) NDBs;
 - f) fixes;
 - g) terminal fixes; and
 - h) user waypoints



Figure 5-38: MFD Symbol Declutter

Turning on VFR airports also turns on large and IFR airports. Turning on IFR airports also turns on large airports. Turning off large airports also turns off IFR and VFR airports. Turning off IFR airports turns off VFR airports.

- 5) **FNCT DCLTR**: Activates a list to individually toggle display of:
 - a) airspace;
 - b) borders;
 - c) datalinked NEXRAD, graphical METARs;
 - d) ETA;
 - e) glide range;
 - f) high-altitude airways;
 - g) low-altitude airways;
 - h) current latitude and longitude display
 - i) ADF #1 pointer;
 - j) ADF #2 pointer;
 - k) VOR1 pointer;
 - l) VOR2 pointer;
 - m) strikes;
 - n) terrain; or
 - o) traffic.

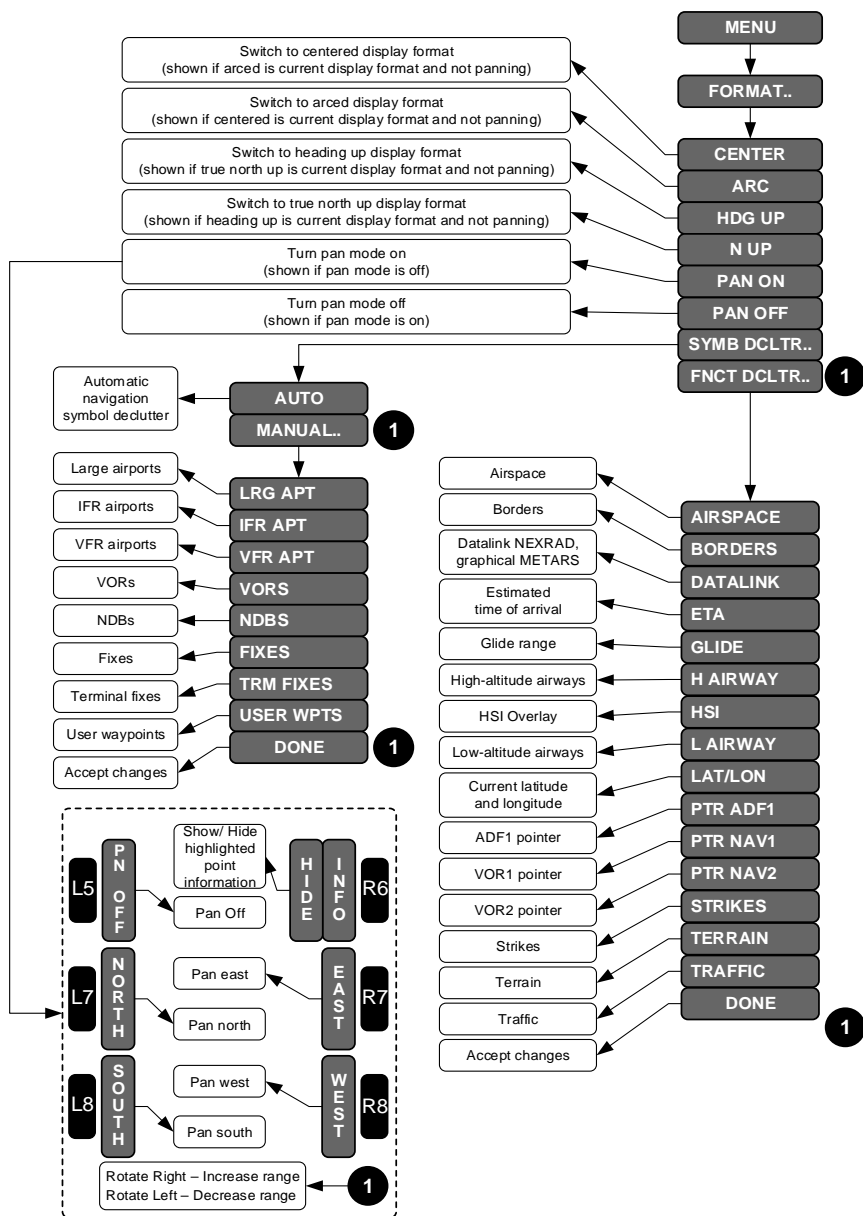

Figure 5-39: MFD Page Format Menu

5.24.1. MFD Page Format (Step-By-Step)

5.24.1.1. Changing MFD ND Orientation



1) Press **MENU (R1)**.



2) Press **FORMAT (R8)**.



3) If in arc mode, rotate **1** to **CENTER** and push to enter to center display.

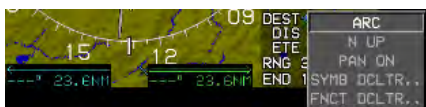

4) If in center mode, rotate **1** to **ARC** and push to enter to change to arc mode.



5) If in HDG UP mode, rotate **1** to **N UP** and push to enter to change display to north-up orientation.



6) To enter pan mode, press **MENU (R1)** and then **FORMAT (R8)**. Rotate **1** to **PAN ON** and push to enter.

7) To turn off pan mode, either press **PN OFF (L5)** or **MENU (R1)** and then **FORMAT (R8)**. Rotate **1** to **PAN OFF** and press to enter.



- 8) Press **NORTH (L7)**, **SOUTH (L8)**, **EAST (R7)**, or **WEST (R8)** to shift to center of the page in the specified direction.
- 9) Press **INFO (R6)** for information on circled highlighted flashing waypoint.

5.24.1.2. Adding LAT/LON to MFD Page



- 1) Press **MENU (R1)**.



- 2) Press **FORMAT (R8)**.



- 3) Rotate **1** to **FNCT DCLTR...**
Push to enter.



- 4) Rotate **1** to **LAT/LON** and either press **EXIT (R1)** or rotate **1** to **DONE** and push to enter.

Latitude/longitude display is removed when a traffic alert is present.

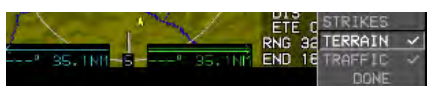

- 5) To turn off terrain, press **MENU (R1)** and then **FORMAT (R8)**. Rotate **1** to **TERRAIN** and push to check or uncheck.

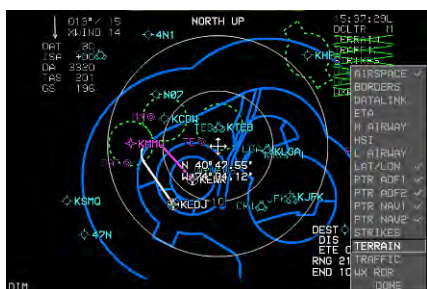

- 6) To exit menu, press **EXIT (R1)** or rotate **1** to **DONE** and push to enter. When the IDU is powered down and reinitialized, terrain remains off until restored.

Section 6 Quick Start Tutorial

Quick Reference Guide (DOC 64-000097-080K)

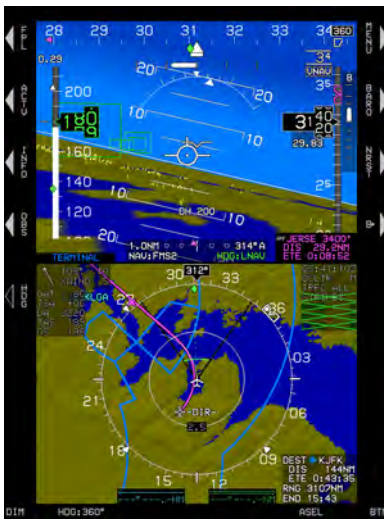

Begin by reading the EFIS Aircraft Flight Manual (AFM) or Aircraft Flight Manual Supplement (AFMS).

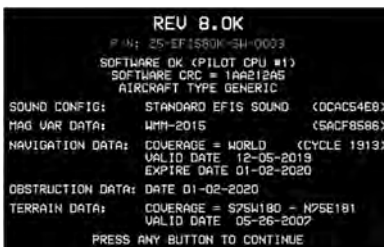

Power up the EFIS. The system performs a built-in test routine. If all tests pass, the system displays a screen identifying the database coverage. Press any button or push/rotate encoders **1**, **2**, or **3** to acknowledge. The system begins a two-minute count down while awaiting sensor initialization. For the purpose of flight planning, etc., press any button to override this countdown.



The encoders at the bottom of the IDU bezel are numbered 1-3 from the right. Rotate **3** to adjust the heading bug setting.

Changing Altimeter Setting on PFD or MFD

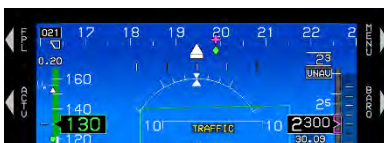

Press **BARO (R2)** and rotate **1** to desired QNH and push to enter.



Rotate **1** to proper setting and push to enter value or press **EXIT (R1)**.



If QFE flight operations are in effect, press **BARO (R2)** and then press **QFE (L2)** to enter QFE mode. Push **1** to accept or press **EXIT (R1)**.



QFE now appears below altimeter window. If set on the ground, the system automatically sets altitude value corresponding with zero altitude.

Creating Direct to Active Waypoint on PFD or MFD



In no active waypoint, press **D (R4)** to enter a destination active waypoint to nearest airport.



Either accept nearest airport or rotate **1** to the desired alpha or numerical character, push to confirm, and advance to the next position. Push to enter until all five spaces have been either entered or viewed.



Magenta star bearing to the waypoint and green diamond ground track symbols are displayed on the directional scale.



A direct route to the active waypoint activates and appears as magenta tethered balloon on the PFI area.

Active Waypoint on PFD



Active waypoint information, including waypoint type and identifier; elevation or crossing altitude; and along-track distance are displayed below the analog AGL indicator, analog G-meter, traffic thumbnail map, or mini map as configured.

Indicated Airspeed, Heading, and Altitude on PFD



Indicated airspeed is on the left, altitude is on the right, and heading is across the top. FMS/VLOC CDI is located on the bottom. VSI appears on the right side of the altitude tape during climbs and descents. Time-critical warnings and cautions are displayed in the primary field of view.

Menu Options on MFD

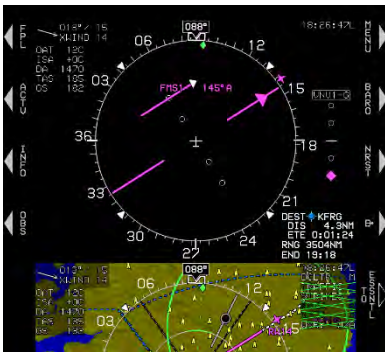

Analog navigation symbology on MFD HSI shown in top area.



On MFD, press **(R5)** to display PFI on top and Map on bottom.



On MFD, press **(R5)** to display MFD page on top and MAP or other pages on the bottom.

Manual Termination Leg (Transmit Enabled IDU only)



An altitude termination leg created within a procedure and indicated inside the active waypoint information box.



Pilot action is necessary to resume normal waypoint sequencing. Press **RESUME (L6)**



After **RESUME (L6)** was pressed, the routing to the next waypoint is resumed as shown with the active waypoint information and the new magenta line on the map. Normal waypoint sequencing has resumed.

Flight Plans (Stored Routes)

Activate Flight Plan on PFD or MFD

- 1) Press **FPL (L1)**.
- 2) On PFD or MFD, push **1** and then rotate to desired flight plan and push to activate.

Create Flight Plan on PFD or MFD

- 1) Press **FPL (L1)**.
- 2) Rotate **1** to **CREATE-EDIT..** and push to enter.
- 3) Rotate **1** to **CREATE FLIGHT PLAN** and push to enter.
- 4) Press **ADD (R6)** to create first waypoint using **1** to enter waypoints from beginning to end, or press **NRST APT (L6)**, **NRST VOR (L7)**, **NRST NDB (L8)**, **NRST FIX (R6)**, **NRST USR (R7)**, or **AIRWAY (R8)** (when applicable) to select next waypoint, and push to enter.
- 5) Press **SAVE (R8)** to save flight plan. (If not pressed, flight plan is not saved.)
- 6) Press **EXIT (R1)** to exit flight planner.

Waypoints

Create a User Waypoint on PFD or MFD

- 1) Press **MENU (R1)**.
- 2) Press **DESIG (L3)**.

Edit a User Waypoint PFD or MFD

- 1) Press **FPL (L1)**.
- 2) Rotate **1** to **CREATE-EDIT..** and push to enter.
- 3) Rotate **1** to **EDIT USER WPT** and push to enter.
- 4) Rotate **1** to highlight waypoint to edit and push to enter.
- 5) Edit waypoint. Press **SAVE (R7)**, **DIR (R8)** to proceed direct to waypoint, or **EXIT (R1)** to exit flight planner.

Add Waypoint to an Active Route on PFD or MFD

- 1) Press **ACTV (L2)**.
- 2) Rotate **1** to location on waypoint list where added waypoint is to be inserted above.
- 3) Press **INSERT (R2)**.
- 4) Press **NRST APT (L2)**, **NRST VOR (L3)**, **NRST NDB (L4)**, **NRST FIX (R2)**, **NRST USR (R3)**, or **AIRWAY (R4)** (when applicable) and then

- a) Rotate **1** to make selection and push to enter, or
 - b) Use **1** to enter waypoint identifier and push to enter.
- 5) Press **SAVE (L1)** to save new active flight plan as another stored flight plan or press **EXIT (R1)** to save changes to active flight plan.

Delete Waypoint from an Active Route on PFD or MFD

- 1) Press **ACTV (L2)**.
- 2) Rotate **1** to waypoint to delete and then press **DELETE (R3)** to prompt **CONFIRM DEL WPT**. If part of a published procedure, press **DELETE (R3)** to prompt **CONFIRM DEL PROC**.
- 3) Push **1** to **CONFIRM DEL WPT** or **CONFIRM DEL PROC**.
- 4) Press **SAVE (L1)** to save new active flight plan as another stored flight plan.

Omnibearing Selector Function

Automatic OBS if in Manual OBS (FMS OBS Only) on PFD or MFD

- 1) Press **OBS (L4)**.
- 2) Press **OBS AUTO (R4)**.
- 3) Push **1** **OBS:AUTO** to enter.

Manual OBS on PFD or MFD

- 1) Press **OBS (L4)**.
- 2) To select HSI source, press **NAV VLOC1 (L3)** or **NAV VLOC2 (L4)**.
- 3) If HSI source is **NAV FMS**, press **OBS MANUAL (R4)** and then rotate **1** to desired OBS value and push to enter, or press **OBS SYNC (R3)** and push **1** to enter.
- 4) If HSI source is **NAV VLOC1 (L3)** or **NAV VLOC2 (L4)**, rotate **1** to desired course (OBS:XXX° (XXX°)) and push to enter.

Approaches/Track

Select a VFR Approach on PFD or MFD

The active flight plan must contain an eligible airport for runway selection and VFR approach creation or user waypoint.

- 1) Press **ACTV (L2)**.
- 2) Rotate **1** to desired airport or user waypoint and push to enter.
- 3) Rotate **1** to **VFR APPR..** and push to enter.
- 4) Rotate **1** to desired runway and push to enter.

Change Runway during VFR Approach on PFD or MFD

This deletes the previous VFR approach and creates a new VFR approach to the selected runway.

- 1) Press **ACTV (L2)**.
- 2) Rotate **1** to any waypoint inside the current VFR procedure and press **DELETE (R3)**. Push **1** to **CONFIRM DELETE PROC.**
- 3) Rotate **1** to desired airport and push to enter.
- 4) Rotate **1** to **VFR APPR..** and push to enter.
- 5) Rotate **1** to desired new runway and push to enter.

Select an IFR Approach on PFD or MFD

- 1) Press **ACTV (L2)**.
- 2) Rotate **1** to desired eligible airport and push to enter.
- 3) Rotate **1** to **IFR APPR..** and push to enter.
- 4) Rotate **1** to desired approach and push to enter.
- 5) Rotate **1** to desired transition and push to enter.
- 6) Rotate **1** to desired runway and push to enter.

Change Runway on IFR Approach on PFD or MFD

This deletes the previous IFR approach and creates a new IFR approach to the selected runway.

- 1) Press **ACTV (L2)**.

- 2) Rotate **1** to any waypoint inside the current Instrument procedure and press **DELETE (R3)**. Push **1** to **CONFIRM DELETE PROC**.
- 3) Rotate **1** to the desired airport, which is now unsuppressed, and push to enter.
- 4) Select **APPR**: Rotate **1** to desired approach. Push to enter.
- 5) Select **TRANS**: Rotate **1** to desired transition. Push to enter.
- 6) Select **RW**: Rotate **1** to desired runway. Push to enter.

Create NRST ILS Approach on PFD or MFD

- 1) Press **NRST (R3)**.
- 2) Rotate **1** to **ILS..** and push to enter.
- 3) Rotate **1** to desired airport beginning with ILS and push to enter.
- 4) Push **1** to **CONFIRM ACTIVATE ILS**.

XFILL SYNC Operation

XFILL Sync Operation on PFD

(Crossfill is the normal default mode of operation.)

- 1) During crossfill inhibited operation, **XFILL INHBT** appears on the PFI in the lower left corner.
- 2) After the XFILL switch is pressed again, the pilot and co-pilot sides are not synchronized, **XFILL ARM** appears in lower left corner of both PFDs.
- 3) When the pilot and co-pilot sides are not synchronized, press **MENU (R1)** then **XFILL SYNC (L1)** to synchronize the pilot and co-pilot active flight plan parameters from the side where the button press occurred.



Section 7 IFR Procedures

7.1. Active Flight Plan

Before using the Genesys EFIS GPS navigation system to fly any part of an instrument procedure in VMC or IMC conditions, always compare each leg of the applicable and current published charted procedure to the flight plan displayed on an MFD page. This EFIS and FMS may not support some specific navigation leg types. All pilots must understand how each leg is depicted and navigated prior to conducting the procedure.

After updating the navigation database and planning to fly an instrument procedure, practice in the RUN DEMONSTRATOR/TRAINING PROGRAM to view how each leg is depicted in the aircraft EFIS limits V_{PROC} setting.

If navigation planning includes manual sequencing of any leg in a procedure, verify what specific navigation guidance the EFIS provides. When any procedure includes ARINC-424 legs defined by headings, or that terminate at a specific altitude, the pilot must understand how the EFIS behaves and how system behavior can affect coupled autopilot operations.

Upon activation of the active flight plan menu, the application checks for an active waypoint. If there is no active waypoint, **NO ACTIVE WPT** appears. Otherwise, a nav log of waypoints in the active flight plan appears with the following:

- 1) Waypoint identifier and characterization (default, overfly [**OF**], or no radius [**OR**])
- 2) Symbol designating waypoint type and what type of procedure (if any) the waypoint is associated
- 3) VNAV altitudes and offsets associated with each waypoint
- 4) Information related to flight plan path between each waypoint

In the case of an approach with a final approach segment data block, the VNAV offset readout associated with the missed approach point is "GPI" to designate distance to the glidepath intercept point. When courses are presented as part of the path information, they are displayed referenced to either magnetic or true north depending upon the status of the true north discrete input. If referenced to magnetic north, the course is indicated with the degree ($^{\circ}$) symbol. Otherwise, a stylized true north (T) symbol appears.

The active waypoint is designated by an asterisk and is magenta but turns amber (yellow) in the event of a GPS LON caution.

Table 7-1: VNAV Altitudes and Offsets

Input Source	Color	
Navigation database or manually entered	KJFK	5000' / +4
	-DIR-	4900' / ---
	*UNUIL	2000' / ---
	TUGGZ	1500' / ---
Computed automatically	KJFK	5000' / +4
	-DIR-	4900' / ---
	*UNUIL	2000' / ---
	TUGGZ	1500' / ---

A suppressed waypoint (designated by brackets) is an airport associated with an IFR or VFR approach procedure. After an approach procedure is activated, the associated airport is no longer part of the active flight plan for guidance purposes. However, the associated airport is still shown in the nav log for it to be highlighted for information or to activate other procedures to the airport. Since only one approach may be active at any given time, only one waypoint may be suppressed by adding an Instrument approach procedure at any given time.

NOTE:

Adding a STAR procedure with no instrument approach nor SID does not suppress the airport waypoint. Adding a STAR to a different airport in the active flight plan does not change the original suppressed waypoint airport.



Figure 7-1: Suppressed Waypoint

It is possible to add a departure procedure to another airport within an active flight plan and have two suppressed waypoints within the same active flight plan.

09:17:32Z GS 204		FUEL 3638LBS FLOW 222PPH				
WAYPOINT	UNAV/OFFSET	PATH	DIST	ETE	ETA	FUEL
(KTEB)		-DISCONT-				
KCDW	3000'	B+ 339°	83.7 _{nm}	0:24	09:52	3507
HNK	3000' ✓	B+ 128°	50.9 _{nm}	0:14	10:17	3416
STAR HELON	3000'	B+ 211°	7.5 _{nm}	0:02	10:32	3361
STAR FLOSI	3000'	B+ 211°	8.0 _{nm}	0:02	10:34	3352
STAR CRANK	3000'	B+ 211°	8.0 _{nm}	0:02	10:36	3344
STAR SHAFF	3000' ✓	B+ 211°	14.0 _{nm}	0:04	10:39	3335
SAX	3000'	B+ 195°	14.3 _{nm}	0:04	10:43	3320
STAR PHLBO	3000'	B+ 190°	10.5 _{nm}	0:03	10:47	3304
STAR HOKIR	3000'	180° -MAN-			10:50	3293
STAR -MAN-	3000'					
(KEWR)		-DISCONT-				
DP RW04L	60' ✓				10:59	3259

Figure 7-2: Active Flight Plan with Two Suppressed Waypoints

A skipped waypoint is a waypoint associated with a dynamic termination leg with a zero length. These are either:

- 1) An altitude termination leg when current aircraft altitude is above the termination altitude; or
- 2) System-created (i.e., not NavData® specified) intercept to a “Course to a Fix” leg where there is insufficient distance to calculate an intercept heading.

To add a waypoint to the end of the active flight plan, rotate through each waypoint of the flight plan to one position past the end. If not, the application makes the selected waypoint active. Otherwise, a list is presented.

Upon selection of a waypoint from the selection list, the EFIS checks whether the selected waypoint meets the criteria for waypoint activation, manual VNAV parameter entry, custom holding pattern entry, SAR pattern entry, SAR pattern segment selection, manual overfly characterization, VFR approach entry, IFR approach entry, STAR entry, or DP entry. If it does, a list is presented as follows:

- 1) **WAYPOINT:** If valid, this option allows the pilot to make the selected waypoint the active waypoint. Option valid for any waypoint except:
 - a) Suppressed waypoint;
 - b) Skipped waypoint;
 - c) A waypoint following a discontinuity; or
 - d) The first waypoint.

- 2) **VNAV:** If valid, this option allows the pilot to enter a manual VNAV altitude and offset for the selected waypoint. This menu level allows for synchronizing the VNAV altitude to current altitude and for removing the manual VNAV altitude and offset entries. These altitudes are settable in increments of 100 feet and distances of 1 NM. Option valid for any waypoint except:
- a) Suppressed waypoint
 - b) Skipped waypoint;
 - c) A manual termination waypoint;
 - d) A waypoint that is part of an IFR or VFR approach;
 - e) A SAR pattern exit waypoint;
 - f) A parallel offset entry or exit waypoint; or
 - g) One of the following types of termination legs:
 - i) Dynamic;
 - ii) Altitude;
 - iii) DME;
 - iv) Radial; or
 - v) Intercept
- 3) **HOLD:** If valid, this option allows the pilot to enter a manual holding pattern at the selected waypoint. Option valid for any waypoint except:
- a) Suppressed waypoint;
 - b) Skipped waypoint;
 - c) A manual termination waypoint;
 - d) A waypoint that is part of a missed approach procedure, including the missed approach waypoint;
 - e) A waypoint that is part of a VFR approach;
 - f) A holding pattern waypoint;
 - g) A SAR pattern exit waypoint;
 - h) A waypoint that begins with a departure procedure;
 - i) A parallel offset entry or exit waypoint; or
 - j) One of the following dynamic termination waypoints:
 - i) Altitude;
 - ii) DME;
 - iii) Radial; or
 - iv) Intercept
- 4) **SAR PTRN:** If valid, this option allows the pilot to create and enter a SAR pattern as defined in the SAR appendix. If SAR patterns are enabled in the EFIS limits this option is valid for any waypoint except:
- a) Suppressed waypoint;
 - b) Skipped waypoint;

- c) A manual termination waypoint;
 - d) A waypoint that is part of an IFR or VFR approach;
 - e) A holding waypoint;
 - f) A SAR pattern exit waypoint;
 - g) A waypoint that begins a departure procedure;
 - h) A parallel offset entry or exit waypoint; or
 - i) One of the following dynamic termination waypoints:
 - i) Altitude;
 - ii) DME;
 - iii) Radial; or
 - iv) Intercept
- 5) **SAR SGMNT:** This option allows the pilot to select which segment within the SAR pattern should be active for navigation guidance. If the selected waypoint is the active waypoint and is one of the following types of SAR patterns:
- a) Expanding square;
 - b) Rising ladder; or
 - c) Sector search
- 6) **OFLY/AUTO:** If the selected waypoint is neither suppressed, skipped, nor a manual termination, change the waypoint's overfly characterization. The choices are:
- a) **AUTO:** Reset automatic overfly characterization by FMS.
 - b) **OVERFLY:** Force the overfly characterization to be an overfly adjust-exit waypoint and force the inbound course to go directly to the waypoint regardless of the amount of course change required.
 - c) **NO RADIUS:** Force the turn radius at the waypoint to be zero. This forces the inbound course and outbound course to go directly to and from the waypoint regardless of the amount of course change required.

NOTE:

It is not possible to track a "NO RADIUS" path perfectly, but the FMS path guidance quickly recaptures the outbound course after resuming automatic waypoint sequencing. Designating a waypoint as a "NO RADIUS" waypoint affects the turn radius used to calculate procedure turn and holding pattern leg paths.

- 7) **VFR APP:** If selected waypoint is a user waypoint with an approach bearing, a VFR approach to the user waypoint based on the approach bearing is created, then the user waypoint becomes suppressed. If the selected waypoint is a VFR airport or an IFR airport with surveyed runways, the pilot is presented with a list of runways. After selecting a runway, a VFR approach to the runway is created, and then the airport waypoint becomes suppressed. Activating a VFR approach deletes any pre-existing IFR or VFR approaches. If a heading bug is not active; activating a VFR approach activates the heading bug on current aircraft heading and is used to define the course intercept angle.
- 8) **IFR APP:** This option is invalid if the selected waypoint is a holding pattern waypoint or SAR pattern exit waypoint. (This forces a pilot to deactivate a manual holding pattern or SAR pattern prior to activating an IFR approach). Otherwise, If selected waypoint is an airport with an IFR approach, the pilot is presented with a list of available approaches (including, if applicable, the five-digit channel number, followed by a list of available transitions, if there are more than one) and a list of runways (if there are surveyed runways at the airport). After selection, the appropriate IFR approach is created, and the airport waypoint becomes suppressed. Activating an IFR approach deletes any pre-existing IFR or VFR approaches. If there is a pre-existing STAR to the airport, the IFR approach waypoints are inserted after the STAR waypoints. If a heading bug is not active and the activated transition is “Vectors to Final,” activating an IFR approach activates the heading bug on current aircraft heading for purposes of defining the course intercept angle.
- 9) **STAR:** This option is invalid if the selected waypoint is a holding pattern waypoint or SAR pattern exit waypoint. (This forces a pilot to deactivate a manual holding pattern or SAR pattern prior to activating an IFR approach). If selected waypoint is an airport with a STAR, the pilot is presented with a list of available STARs, followed by a list of available transitions (if there are more than one) and a list of runways (if there are surveyed runways at the airport). After selection, the appropriate STAR is created. Activating a STAR automatically deletes any pre-existing STAR. If there is a pre-existing approach (IFR or VFR) to the airport, STAR waypoints are inserted prior to the approach waypoints.
- 10) **DP:** This option is invalid if the selected waypoint is a holding pattern waypoint or SAR pattern exit waypoint. (This forces a pilot to deactivate a manual holding pattern or SAR pattern prior to activating an IFR approach). If selected waypoint is an airport with a DP, the pilot is presented with a list of DPs, followed by a list of available transitions (if there are more than one) and a list of runways (if there are surveyed runways and more than one runway authorized for the DP). After selection, the appropriate DP is created, and upon activation, deletes any pre-existing DPs.

7.2. IFR Procedures

Pilots operating in a radar environment are expected to associate departure headings or an RNAV departure advisory with vectors or the flight path to the planned route or flight. The EFIS employs two types of departure procedures (DP); obstacle departure procedures (ODP), which are printed either textually or graphically, and standard instrument departure procedures (SID), which are always printed graphically. All DPs, either textual or graphic may be designed using either conventional or RNAV criteria. RNAV procedures have RNAV printed in the title.

ODPs are not found in NavData[®], therefore the climb angle found in the PFD BUGS menu should be set to comply with the steeper than normal climb gradient during the departure until established on the enroute structure. ODPs are recommended for obstruction clearance and may be flown without ATC clearance, unless an alternate departure procedure (SID or radar vector) has been specifically assigned by ATC.

Approach minima are never coded in NavData[®]. On some approaches, the altitude coded at the MAP for a non-precision approach coincides with an MDA (normally where the final approach course does not align with the runway), but more often the coded altitude is some height above the threshold.

7.3. Overview of Procedures and Instrument Approaches

This EFIS provides 3D GPS precision and non-precision instrument approach guidance using a system integral TSO C146c BETA 3 GPS receiver with GPS and augmented GPS with SBAS (Satellite Based Augmentation System) commonly referred to as WAAS (Wide Area Augmentation System).

Use of this GPS receiver provides a level of certified service supporting RNAV (GPS) approaches to LNAV, LP, LNAV/VNAV, and LPV lines of minima within system coverage. Some locations close to the edge of the coverage may have lower availability of vertical guidance.

Approach with vertical guidance (APV) procedures are defined in ICAO Annex 6 and include approaches such as the LNAV/VNAV procedures presently being flown with barometric vertical navigation (BARO-VNAV). These approaches provide vertical guidance but do not meet the more stringent standards of a precision approach. With the WAAS BETA 3 GPS receiver and updatable navigation database in this system, these approaches may be flown using an electronic glidepath, which eliminates errors introduced by using barometric altimetry.

In addition to LNAV/VNAV procedures, APV takes advantage of the high accuracy guidance and increased integrity provided by GBS/SBAS. This

SBAS (TEROS/ICAO) generated angular guidance allows use of the same TERPS approach criteria for ILS approaches. The resulting approach procedure minima, localizer performance with vertical guidance (LPV), have a decision altitude as low as 200 feet height above touchdown (EASA OPS LPV 250 ft.) with visibility minimums as low as ½ mile (providing the terrain and airport infrastructure and regulations support the lowest minima criteria).

Another non-precision GPS/SBAS approach, certified as an localizer performance (LP) approach where terrain or obstructions prohibit the certification of the LPV vertically guided approach, takes advantage of the angular lateral guidance and smaller position errors (provided by GPS/SBAS) to provide a lateral only procedure similar to an ILS localizer. LP procedures may provide lower minima than a LNAV procedure due to the narrower obstacle clearance surface. In the LP approach, vertical guidance is for information only and is based on SBAS or BARO information.

The EFIS guides the pilot through every step of the approach procedure with Highway in the Sky (HITS) 3D symbology. The system defines a desired flight path based upon the active flight plan. The current position of the aircraft is determined relative to the desired path in order to determine lateral deviation for display on the GPS/SBAS CDI and VDI. The EFIS auto-sequences from one waypoint to the next in accordance with the flight plan along the flight path with the following exceptions:

- 1) Pilot has selected a manual GPS/SBAS OBS (**SUSPEND** shown).
- 2) Active waypoint is the missed approach waypoint, and missed approach procedure has not been armed (**ARM**) nor initiated (**MISS**) (**SUSPEND** shown).
- 3) Aircraft is in a published or manually created holding pattern, and pilot has not chosen to continue (**CONT**) out of the holding pattern (**SUSPEND** shown).
- 4) Active waypoint is the last waypoint of the active flight plan (no flag shown).
- 5) Leg following active waypoint is a manual termination leg, and the pilot has not chosen to resume (**RESUME**) to the waypoint following the manual termination (**SUSPEND** shown).
- 6) The aircraft is in a repeating SAR pattern (race track, sector search, or orbit) and the pilot has not chosen to continue out of the SAR pattern (**SUSPEND** shown). (See SAR appendix.)

Where automatic waypoint sequencing is suspended due to reasons 1, 2, or 4 above, the EFIS automatically switches from TO operation to FROM operation when appropriate. If not suspended, automatic waypoint sequencing occurs upon the following conditions:

- 1) Bearing to the transition point (turn bisector for the fly-by waypoint, active waypoint for fly-over waypoint) is more than 90° from the current course (transition from “TO” to “From” operation);
- 2) Aircraft location is within one turn diameter (based upon current true Airspeed and 15° angle of bank) of the transition point; and
- 3) Aircraft heading is within 90° of the current course (generally pointed in the correct direction).

7.3.1. Highway in the Sky (Skyway)

When not decluttered, the PFD displays the active navigation route or manual OBS course 3D manner with a series of skyway boxes, which overlay the flight plan route at a desired altitude and provide lateral and vertical guidance. Skyway boxes conform to the VNAV requirements of GPS/SBAS receiver requirements (TSO-C-146C). The top and bottom of the boxes are parallel to the horizon on straight leg segments and dynamically tilt with respect to the horizon on turning leg segments based on leg-segment turn radius and groundspeed.

Table 7-2: Highway in the Sky Configuration

Type HITS Lines	Fully Integrated Autopilot	Genesys/S-TEC DFCS (HDG and/or NAV/APR mode)	Un-Integrated Autopilot or No Autopilot
Dashed	Not coupled to skyway		
Solid	Coupled to Skyway	Coupled to skyway. Autopilot is either in HDG mode with LNAV heading/roll-steering sub-mode engaged or in NAV/APR mode with FMS1 or FMS2 as the selected navigation source.	Always Solid

When the active route is in view, up to five boxes are shown with the dimensions being a constant 400 feet wide (±200 feet from the desired lateral path) by 320 feet tall (±160 feet from the desired vertical path) spaced horizontally 2000 feet. Skyway boxes are drawn using the hidden surface removal techniques of the terrain and obstruction rendering, so a skyway box behind terrain appears to be so. Skyway boxes disappear in basic mode and unusual attitude mode. In reversionary mode 1 (GPS

failure), skyway boxes disappear after one minute to indicate degraded navigation performance.

Skyway box altitude is controlled by VNAV altitude, aircraft altitude, aircraft climb performance, and climb/descent angle setting. If no VNAV altitude is set, skyway boxes describe the desired lateral flight path of the aircraft at the aircraft's current altitude.

With a VNAV altitude set, the boxes provide both lateral and vertical guidance. Climb and descent angle settings are controlled individually with a resolution of 0.1°. VNAV is guided by VNAV waypoints determined by VNAV altitude and VNAV offset from flight plan waypoints. There are two sources for VNAV altitudes, the navigation database and manual input through the ACTV menu, which are automatically computed by the system using "look-ahead" rules. When "look-ahead" finds a further VNAV altitude constraint above the previous VNAV altitude constraint (i.e., climb commanded), an automatic VNAV altitude is continuously calculated for the waypoint based upon an immediate climb to the altitude constraint at the higher of actual climb angle or the climb angle setting (dynamic climb angle). When "look-ahead" finds a further VNAV altitude constraint below the previous VNAV altitude constraint (i.e., descent commanded), an automatic VNAV altitude is calculated for the waypoint based on a descent to reach the VNAV altitude constraint at the associated waypoint using the descent angle setting. If no further VNAV altitude constraints are found, the automatic VNAV altitude is set to the last valid VNAV altitude constraint.

When a VNAV climb is desired, the boxes are drawn at a vertical position the higher of: (a) the dynamic climb angle emanating from the aircraft's present position (aircraft-referenced); (b) the dynamic climb angle emanating from the next waypoint VNAV altitude (geo-referenced forward); or (c) the climb angle setting emanating from the previous waypoint VNAV altitude (geo-referenced backward). The geo-referenced backward calculation is only considered when the current leg is part of a procedure and is designed to provide pilot awareness, if a specified climb gradient is not being met. Once the boxes intercept the VNAV altitude, further boxes are drawn with a zero angle to show a level off followed by a level flight segment as an anticipatory cue for planning. Climb guidance is depicted in Figure 7-3, Figure 7-4, and Figure 7-5.

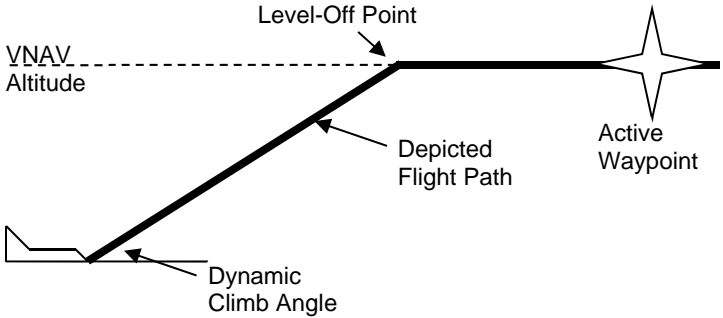

Figure 7-3: Highway in the Sky (Aircraft Referenced)

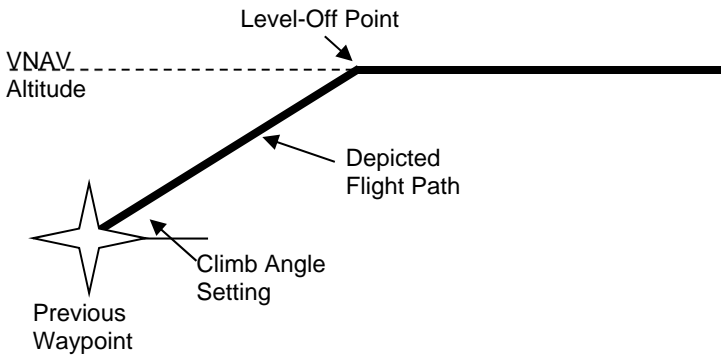

Figure 7-4: Highway in the Sky (Geo-Referenced Backward)

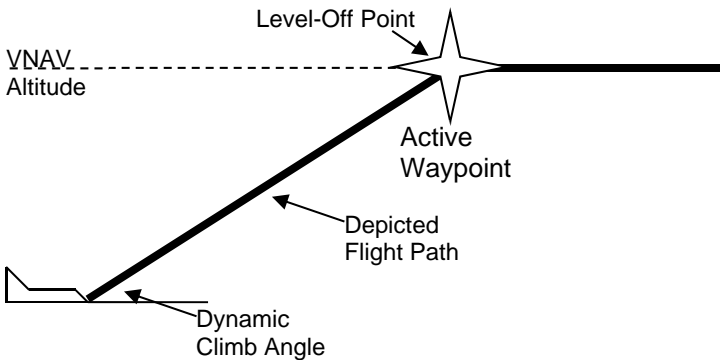

Figure 7-5: Highway in the Sky (Geo-Referenced Forward)

When a VNAV descent is desired, boxes are drawn with a zero angle until reaching a descent point. Further boxes are drawn downward at an angle corresponding to the descent angle setting. The descent point is defined

by the intercept of a line emanating upward from the subsequent VNAV waypoint at the descent angle setting and a line representing level flight at the previous VNAV altitude. On the final approach segment of an IFR approach, descent angle and VNAV waypoint are defined in Table 7-3.

Table 7-3: Final Segment of IFR Approach, Descent Angle and VNAV Waypoint

Condition	VNAV Waypoint	Descent Angle
IFR approach with valid final approach segment data block	Glidepath intercept point (GPIP) as defined in final approach segment data block	Descent angle as defined in final approach segment data block
No or invalid final approach segment data block No intermediate waypoints exist between FAF and MAP	Missed approach point location	Straight line from FAF to MAP location and altitudes.
No or invalid final approach segment data block Intermediate waypoints exist between FAF and MAP	Missed approach point location	Steepest descent angle based upon straight lines from FAF and sub-subsequent intermediate waypoints to MAP location and altitudes

On the final approach segment of a VFR approach procedure, the higher of the descent angle setting or 3° is used.

Because five boxes are shown, the descent point depiction is an anticipatory cue. Figure 7-6 depicts descent guidance and creates an easily understood, yet safe, VNAV paradigm to meet the VNAV requirements current guidance.

Further, the paradigm is biased towards keeping the aircraft at the highest altitude possible for the longest period of time. The climb paradigm compensates for an aircraft's ability to climb more steeply than specified and warns of being below a desired climb gradient when the aircraft is unable to meet the specified climb angle. The descent paradigm encourages flying stabilized approaches.



Figure 7-6: Highway in the Sky Final Approach Segments

7.3.2. Waypoint Sequencing

When automatic waypoint sequencing is suspended due to reasons 1, 2, or 4 in § 7.3, the EFIS switches from “TO” to “FROM” operation when appropriate. If not suspended, automatic waypoint sequencing occurs in following conditions:

- 1) Bearing to the transition point (turn bisector for fly-by waypoint, active waypoint for fly-over waypoint) is more than 90° from the current course (i.e., transition from “TO” to “FROM” operation);
- 2) Aircraft location is within two turn diameters (based upon current true airspeed and 15° angle of bank) of the active waypoint location; and
- 3) Aircraft is within 90° of the current course (i.e., generally pointed in the correct direction).

The desired flight path is created from a sequence of straight, left turning, and right turning leg segments designed to provide smooth skyway, GPS/SBAS CDI, and lateral autopilot guidance. Each leg between waypoints is composed of up to nine segments. Otherwise, radii for turning segments (other than DME arc or radius to a fix segments) are calculated with the parameter speed determined as follows:

- 1) If the waypoint is part of a DP and within 30NM of the departure runway, speed is the preprogrammed procedure speed.
- 2) If the waypoint is part of a STAR and within 30NM of the arrival runway, speed is the preprogrammed procedure speed.

- 3) If the waypoint is part of an IFR or VFR approach procedure, speed is the preprogrammed procedure speed.
- 4) If the waypoint is part of a holding pattern, speed is the preprogrammed holding speed.
- 5) Within a SAR pattern, speed is the lower of holding speed or procedure speed.
- 6) Where a fixed-radius transition (FRT) is defined by the navigation database for a waypoint, that turn radius is used for the turning segment. FRT is used in enroute flight in order to save the number of waypoints and to provide a smoother transition. The RF leg can only be used in a SID or in a STAR. It is the flight plan leg stored in the navigation database, which is defined by constant radius turns around a given fix.
- 7) Otherwise, speed is the current true airspeed or procedure speed, whichever is higher.

In all cases, if NavData[®] derived speed limit is associated with the waypoint, speed is the lower of the NavData[®] derived speed limit or the speed determined above.

Radius for DME arc or radius to a fix segments comes from NavData[®].

7.3.3. Fly-Over Waypoints

To create the desired flight path, each waypoint is designated as a fly-by or a fly-over waypoint. Waypoints are further subdivided into waypoints with a defined entry heading and waypoints with a defined exit heading. Waypoint auto-sequencing for fly-by waypoints occurs at the bisector of the turn. Waypoint auto-sequencing for fly-over waypoints occurs over the waypoint.

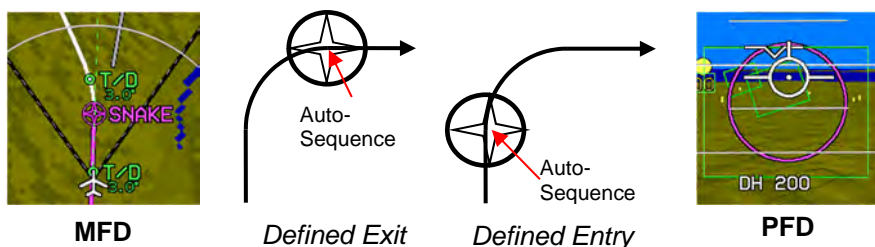

Figure 7-7: Fly-Over Waypoints

These waypoints are type fly-over with defined entry heading:

- 1) Waypoint leading into discontinuity;

- 2) Waypoints which are marked as overfly in the navigation database or menu system;
- 3) Exit from holding pattern;
- 4) Exit from procedure turn;
- 5) Entry into holding pattern;
- 6) Missed approach point;
- 7) Phantom waypoint (created by inserting a waypoint into the active flight plan or performing Direct-To function within the active flight plan – avoids S-turns);
- 8) Last waypoint;
- 9) Start waypoint (created by creating a new active flight plan with the Direct-To function – avoids S-turns);
- 10) Reference (takeoff runway end) waypoint of a DP;
- 11) Waypoint leading into discontinuity; and
- 12) Altitude, DME, or radial termination legs (ARINC-424 path types CA, FA, VA, CR, VR, CD, FD, and VD; see Table 7-4).
- 13) Waypoints marked as overfly in the navigation database.

Table 7-4: RNAV Path Terminator Leg Type

Path	Designator		Terminator
Constant DME arc	A	A	Altitude
Course to	C	C	Distance
Direct Track	D	D	DME Distance
Course from a Fix to	F	F	Fix
Holding Pattern	H	I	Next Leg
Initial	I	M	Manual Termination
Constant Radius	R	R	Radial Termination
Track Between	T		
Heading To	V		
Examples: CF = Course to Fix, and FM = Course from a Fix to a Manual Termination, etc.			

The following waypoints are fly-over with a defined exit heading:

- 1) Waypoint exiting a discontinuity with the exception of start, phantom or DP reference points;

- 2) Entry into procedure turn; and
- 3) First waypoint with the exception of start or DP reference points.

7.3.4. Fly-By Waypoints

- 1) CF legs with defined Entry Heading
- 2) All other waypoints with defined Exit Heading

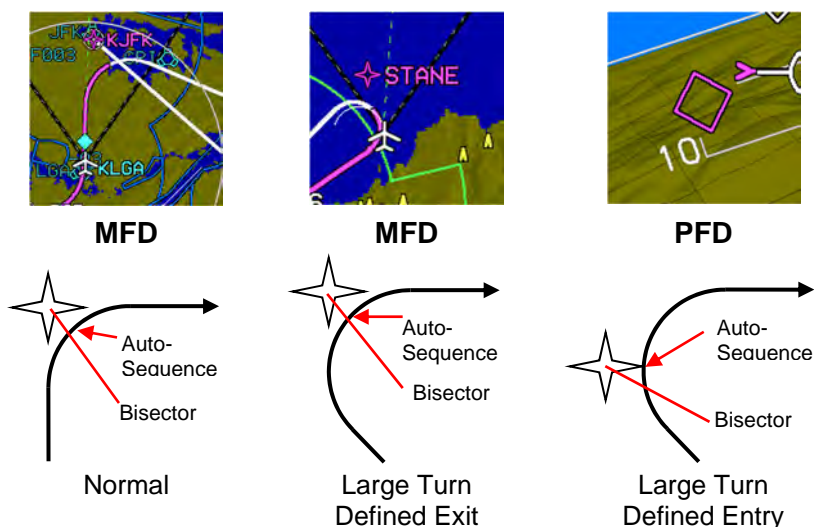

Figure 7-8: Fly-By Waypoints

NOTE:

Entry adjustments should be expected anytime a turn exceeds 120°. Turns greater than 120° should not be used in conjunction with RNP routes. (RNP standards specifically exclude such turns from RNP requirements.)

Leg segments for paths are constructed by the EFIS as in Table 7-5.

Table 7-5: Leg Segments for Paths Constructed by EFIS

Path Type	Waypoint		# of Segments and Description
	Entry	Exit	
Straight Leg, DME Arc or Radius to a Fix	Fly-By	Fly-By	2nd half of fly-by turn at entry waypoint. WGS-84 geodesic or arc path from entry to exit turns. 1st half of fly-by turn at exit waypoint.
	Fly-By	Fly-Over Defined Exit Heading	2nd half of fly-by turn at entry waypoint. WGS-84 geodesic or arc path from entry to exit turns. Turn to exit heading prior to exit waypoint.
	Fly-By	Fly-Over Defined Entry Heading	2nd half of fly-by turn at entry waypoint. WGS-84 geodesic or arc path from entry turn to exit waypoint.
	Fly-Over Defined Exit Heading	Fly-By	WGS-84 geodesic or arc path from entry waypoint to exit turn. 1st half of fly-by turn at exit waypoint.
	Fly-Over Defined Exit Heading	Fly-Over Defined Exit Heading	WGS-84 geodesic or arc path from entry waypoint to exit turn. Turn to exit heading prior to exit waypoint.
	Fly-Over Defined Exit Heading	Fly-Over Defined Entry Heading	WGS-84 geodesic or arc path from entry waypoint to exit waypoint.
	Fly-Over Defined Entry Heading	Fly-By	Turn from entry heading after entry waypoint. WGS-84 geodesic or arc path from entry to exit turns. 1st half of fly-by turn at exit waypoint.
	Fly-Over Defined Entry Heading	Fly-Over Defined Exit Heading	Turn from entry heading after entry waypoint. WGS-84 geodesic or arc path from entry to exit turns. Turn to exit heading prior to exit waypoint.
	Fly-Over Defined	Fly-Over Defined	Turn from entry heading after entry waypoint.

Table 7-5: Leg Segments for Paths Constructed by EFIS

Path Type	Waypoint		# of Segments and Description
	Entry	Exit	
	Entry Heading	Entry Heading	
			WGS-84 geodesic or arc path from entry turn to exit waypoint.
Procedure Turn	Fly-Over Defined Exit Heading	Fly-Over Defined Entry Heading	<p>WGS-84 geodesic path from entry waypoint on outbound heading for 30 seconds.</p> <p>Turn to procedure turn heading (45°).</p> <p>Outbound on procedure turn heading for 72 seconds.</p> <p>Turn to inbound heading (135°).</p> <p>WGS-84 geodesic path to exit waypoint. Entry waypoint and exit waypoint are same point.</p>
Holding Pattern	Fly-Over Defined Entry Heading	Fly-Over Defined Entry Heading	<p>Turn to proper entry procedure heading. This heading varies. For a parallel entry, it is 180° from the holding course. For direct and teardrop entries, it is the heading required to get to entry of inbound turn.</p> <p>WGS-84 geodesic path to entry of inbound turn.</p> <p>Inbound turn. Degree of turn varies depending upon entry procedure and heading.</p> <p>WGS-84 geodesic path to holding fix for direct and teardrop entries. WGS-84 geodesic path to entry of turn to holding pattern heading for parallel entries.</p> <p>Turn to holding pattern heading for parallel entries. This leg is not used for direct and teardrop entries.</p> <p>Turn to holding pattern outbound leg (180°).</p> <p>Holding pattern outbound leg (length based upon either time or distance as specified by navigation database).</p>

Table 7-5: Leg Segments for Paths Constructed by EFIS

Path Type	Waypoint		# of Segments and Description
	Entry	Exit	
			Turn to holding pattern inbound leg (180°). Holding pattern inbound leg (length based upon either time or distance as specified by navigation database).

7.3.5. Direct-To

If the EFIS generates a WGS-84 geodesic path to a designated “To” fix, the aircraft captures this path without “S-turning” or undue delay. Where the selected “To” fix is in the active flight plan, the required transition is created as follows:

- 1) A phantom waypoint is created at the current aircraft location.
- 2) Leg prior to the phantom waypoint is designated a discontinuity.
- 3) Phantom waypoint is designated a fly-over defined entry heading waypoint where entry heading is current aircraft track.

Where the selected “To” fix is not in the active flight plan, the required transition is created as follows:

- 1) A new active flight plan is created from “Start” (current aircraft location) to the “To” fix.
- 2) “Start” waypoint is designated a fly-over defined entry heading waypoint where entry heading is current aircraft track.

7.3.5.1. Direct-To Unnamed Waypoints Inside Procedures

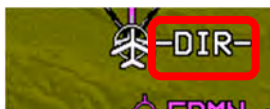
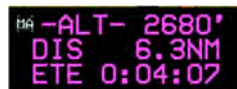
**Active Flight Plan****MFD Navigation Display****PFD Waypoint Information****Figure 7-9: Unnamed Waypoints**

The following identifiers are implemented for unnamed waypoints inside a published procedure and are found on the map or inside the active flight plan.

- 1) **-ALT-** for altitude terminations
- 2) **-DIR-** for waypoints that begin a Direct-To leg
- 3) **-DME-** for distance or DME terminations
- 4) **-INT-** for intercept terminations
- 5) **-RAD-** for radial terminations
- 6) **-MAN-** for manual terminations

7.4. Discontinuities

When the EFIS is unable to construct a smooth flight path, as described above due to active flight plan waypoint spacing (i.e., spacing too close for turn radius), a discontinuity is placed between the waypoints. When a discontinuity exists, no path nor skyway is drawn between the waypoints. The pilot cannot activate the waypoint exiting the discontinuity, as it is not possible to provide path guidance to this waypoint. Attempts to activate the waypoint exiting the discontinuity activates the next waypoint or, if there is no next waypoint (i.e., end of active flight plan), activation of the waypoint leading into the discontinuity.

7.4.1. Manual Termination Legs

Manual termination legs (ARINC-424 path types FM and VM) are a special case and are handled as follows:

- 1) The manual termination leg is rendered as a path on the database course/heading for 10NM beyond either:
 - a) the previous waypoint (manual leg not active); or
 - b) the nearest on-path point (manual leg active);
- 2) Rendering of the manual termination leg does not terminate with a waypoint symbol;
- 3) The manual termination leg is followed by a discontinuity;
- 4) Waypoint sequencing is suspended on the manual termination leg;
- 5) Once on the manual termination leg, **RESUME (L6)** appears;
- 6) When ready to end manual navigation and resume a path to the waypoint following the manual termination leg, press **RESUME (L6)** to create and activate a Direct-To path to the waypoint.

NOTE:

If the manual termination leg is not followed by another waypoint (other than a suppressed waypoint), **RESUME (L6)** does not appear, because there would be no waypoint-to-waypoint sequencing to resume.

7.5. Magnetic Course

The source of magnetic variation used for paths defined using magnetic course is in accordance with the following:

- 1) If the leg is part of a database terminal area procedure and the magnetic variation is specified by the State for that procedure, the magnetic variation to be used is the value specified.
- 2) If the leg is not part of a procedure and the active fix is a VOR, the magnetic variation to be used is the published station declination for the VOR.
- 3) If the leg is not part of a procedure and the terminating fix is not a VOR, the magnetic variation to be used is defined by the system using an internal model.

The EFIS is capable of computing magnetic variation at any location within the region where flight operations may be conducted using magnetic north reference. The assigned magnetic variation is calculated using the NIMA GEOMAG algorithm and world magnetic model appropriate to the five-year cycle in a MAGVAR database.

7.5.1. AHRS Modes for Heading Source

AHRS Slaved—EFIS Magnetic North: Standard mode of operation. Everything displayed relative to magnetic north drift free.

AHRS Slaved—EFIS True North: Everything displayed relative to true north with drift free heading. The preferred way to operate in areas where navigation is done relative to true north. (See Section 9 Appendix for limitations on Earth's magnetic flux horizontal field.)

AHRS Free/"DG"—EFIS Magnetic North: Use when operating around significant magnetic disturbances in areas where navigation is done relative to magnetic north. Ensure the compass rose is slewed to a magnetic north value.

AHRS Free/“DG”—EFIS True North: Method of operation in high-latitude areas where navigation is accomplished relative to true north. Heading is not drift free and requires periodic correction. This mode may also be used when operating around significant magnetic disturbances in areas where navigation is done relative to true north. Ensure the compass rose is slewed to a true north value.

7.5.2. EFIS True North Mode

True north mode is selectable either through **OBS (L4), TRUE NORTH (L1)** or a discrete input external switch. This mode is intended to address aircraft requirements during high or low latitude operations and should be used when the AHRS has been set to free-gyro mode. See Section 3 Display Symbolology for symbolology examples while in true north mode.

7.6. GPS Altitude

WGS-84 ellipsoid altitude received from the GPS/SBAS is converted to geodetic (MSL) altitude using the EGM 2008 geoidal database, which is revised on a twelve-year cycle.

7.7. Dead Reckoning

The EFIS has dead reckoning capability and is active whenever the GPS/SBAS sensor is not sending a valid position. The EFIS projects the last known GPS/SBAS position forward using TAS and heading, corrected for last known wind as it continues to navigate using this position and the active flight plan. The system provides the capability to determine bearing to an airport, based upon the dead reckoning position.

7.8. Geodesic Path Computation Accuracy

The cross-track path deviation error between the computed path used to determine cross-track deviations and the true WGS-84 geodesic is less than 10% of the horizontal alert limit of the navigation mode applicable to the leg containing the path.

7.9. Parallel Offsets

The parallel offset is a route parallel to, but offset from, the original active route. The basis of the offset path is the original flight plan leg(s) and one or more offset reference points as computed by the EFIS. The computed offset reference points are located so they lie on the intersection of lines drawn parallel to the host route at the desired offset distance and the line that bisects the track change angle, except where the parallel offset ends. In this case, the offset reference point is located abeam of the original flight plan waypoint at the offset distance.

The parallel offset function is not available nor applies to:

- 1) Legs that are parts of approach procedures (IFR and VFR); or
- 2) Legs with complex geometries or that begin or end with dynamically terminations. (ARINC-424 path types other than CF, DF, or TF or any leg where the starting waypoint is not a fixed position); or
- 3) Legs that begin at an aircraft starting position (reference waypoint in a DP or Start/Phantom waypoints created by the Direct-To function).

Parallel offset function does not propagate through the following:

- 1) Any waypoint at the beginning or end of a route discontinuity; or
- 2) Any waypoint at the beginning or end of a prohibited leg type; or
- 3) A waypoint with an unreasonable path geometry (defined as a turn greater than 120°).



Figure 7-10: Parallel Offset PTK-/PTK ENTRY

When the parallel offset function begins or ends within a flight plan due to the above constraints, parallel offset entry (PTK+) or exit (PTK-) waypoints are inserted into the flight plan. **PTK ENDING** appears in sufficient time to alert the pilot to return to the original path. Discontinuities precede parallel offset entry waypoints and follow parallel offset exit waypoints. This allows the pilot to navigate to and from the parallel offset as required.



Figure 7-11: Parallel Offset PTK-/PTK ENDING







The EFIS provides guidance to parallel tracks at a selected offset distance. When executing a parallel offset, the navigation mode and all performance requirements of the original route in the active flight plan are applicable to the offset route. The EFIS provides for entry of offset distance in increments of 1 NM, left or right of course, and is capable of offsets of at least 20 NM. Offset mode is indicated with an advisory flag, e.g., **PTK = L 20NM**. When in offset mode, the EFIS provides reference parameters (e.g., cross-track deviation, distance-to-go, time-to-go) relative to the offset path and offset reference points.

Once a parallel offset is activated, the offset remains active for all flight plan route segments until removed automatically (transitioning through a parallel track exit waypoint), until the flight crew enters a “Direct-To” routing or activates a new flight plan route, or until (manual) cancellation.

NOTE:

If a parallel offset is entered in the active flight plan and then cancelled, that active flight plan is no longer eligible for configuring another parallel offset without deleting and reopening due to the creation of a discontinuity.

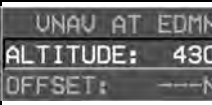
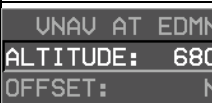
Table 7-6: Parallel Offsets Symbols and Description

Symbol	Description
	Parallel offset has been created and has a designated ending waypoint.
	Designated ending waypoint of parallel offset
	Parallel track advisory indicating offset track 3 NM to the right of host route.
	PTK (L4) appears when active route is eligible for a parallel offset.
	Approaching end of parallel offset waypoint
	VNAV altitude is possible with offset of distance before or after waypoint.
	VNAV altitude input is possible but not an offset of a distance before or after waypoint.
	The absence of PTK (L4) indicates a parallel offset is not allowed for reasons stated above.
	Indicates each waypoint is a part of the parallel offset.

7.10. Default GPS/SBAS Navigation Modes

In the default GPS/SBAS mode, the EFIS has enroute, terminal, LNAV approach, LNAV/VNAV approach, LP approach, LPV approach, VFR approach, and departure navigation modes. Mode annunciation, alert limits (horizontal and vertical), and CDI FSD (horizontal and vertical) are determined by navigation mode.

Table 7-7: Default GPS/SBAS Navigation Modes

Navigation Mode	Annunciation
Enroute	None
Terminal	TERMINAL
LNAV Approach	LNAV APPR
LNAV/VNAV Approach	LNAV/VNAV APPR
LP Approach	LP APPR
LPV Approach	LPV APPR
VFR Approach	VFR APPR
Departure	TERMINAL

The system switches to default navigation modes based upon region of operation as in Table 7-8.

Table 7-8: Default Navigation Modes Based Upon Region of Operation

Default Navigation Mode	Definition of Region
Departure	Selected when active waypoint is first waypoint of a departure or missed approach procedure <u>and</u> active leg heading is aligned ($\pm 3^\circ$) with active runway heading. Also set when active waypoint is MAWP but a missed approach has been manually activated.
VTF Approach (LNAV, LNAV/VNAV, LP or LPV)	VTF IFR approach has been selected; <u>and</u> within 30NM of the active runway; <u>and</u> FAWP is active waypoint*; <u>and</u> bearing to FAWP is within 45° of final approach segment track (treated as a mode entry criteria); <u>and</u> desired track to FAWP is within 90° of final approach segment track (treated as a mode entry criteria).
Approach (LNAV, LNAV/VNAV, LP or LPV)	IFR approach has been selected; <u>and</u> within 30NM of the active runway; <u>and</u> MAWP or FAWP is active waypoint; <u>and</u> if FAWP is active waypoint: bearing to FAWP is within 45° of final approach segment track (treated as a mode entry criteria); <u>and</u>

Table 7-8: Default Navigation Modes Based Upon Region of Operation

Default Navigation Mode	Definition of Region
	desired track to FAWP is within 90° of final approach segment track (treated as a mode entry criteria); <u>and</u> either segment leading into FAWP is not a holding pattern, or pilot has elected to continue out of holding.
VFR Approach	VFR approach has been selected; <u>and</u> within 30NM of the active runway; <u>and</u> active runway is the active waypoint; <u>and</u> the bearing to the active runway/user waypoint is within 45° of the final approach segment track (treated as a mode entry criteria); <u>and</u> the aircraft track is within 90° of the final approach segment track (treated as a mode entry criteria).
Terminal	Not in departure mode; <u>and</u> not in approach mode; <u>and</u> active waypoint is part of a departure <u>or</u> active waypoint and previous waypoint are parts of an arrival or approach <u>or</u> within 30NM of the departure airport, arrival airport, or runway.
Enroute	Not in departure, approach, nor terminal modes

NOTE:

During RNP 0.3 approach (manually or coded), scale remains in RNP 0.3.

7.11. GPS/SBAS CDI Scale

Table 7-9: Summary of Changes In Cross-Track FSD

	To Enroute	To Terminal	To Approach
From Enroute		Change from ± 2 NM FSD to ± 1 NM FSD over distance of 1 NM; start transition when entering terminal mode.	

Table 7-9: Summary of Changes In Cross-Track FSD

	To Enroute	To Terminal	To Approach
From Terminal	Change from ± 1 NM FSD to ± 2 NM FSD over distance of 1 NM; start transition when entering enroute mode.		If VTF, switch immediately. Otherwise, change from ± 1 NM FSD to approach FSD over distance of 2 NM; start transition at 2 NM from FAWP.
From Approach		Change to ± 1 NM.	
From Departure		If initial leg is aligned with runway, change from ± 0.3 NM FSD to ± 1 NM FSD at turn initiation point of first fix in departure procedure.	

Table 7-10: Summary of Typical Mode Switching Transitions

To/From	Enroute	Terminal	Approach
From Enroute		Sequence the first waypoint in arrival route; or 31 NM from destination airport/MAWPLTP/FTP	N/A
From Terminal	Sequence the last departure waypoint, if applicable, and ≥ 30 NM from departure airport.		Selection of VTF approach; or the FAWP is the active waypoint and the bearing to FAWP is within 45° of the desired track of the final approach segment.
From Approach	After pilot deselects approach, or after initiation of missed approach procedure, either sequencing the MAWP (for missed approach procedures that do not start with a TF leg aligned $\pm 3^\circ$ of the final approach path) or at the turn initiation point for the first waypoint in the missed approach procedure (for missed approach procedures that start with a TF leg $\pm 3^\circ$ of the final approach path); executing a Direct-To; or end of flight.		

NOTE:

For RNP 0.3 routes, time to alert (TTA) is the same as for the approach. For RNP 0.3, the EFIS uses a 10-second TTA when using GPS-only, and a 2-second TTA when using EGNOS.

7.11.1. Alerting Scheme for LNAV/VNAV Procedures

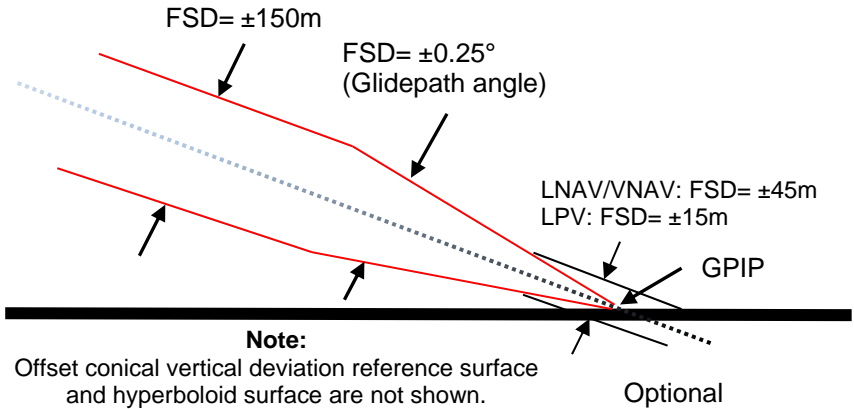

Figure 7-12: Vertical Deviation Indicator Linear Deviation

During normal operation with FMS source of navigation guidance, when an LNAV/VNAV procedure has been entered into the active flight plan and the EFIS is in LNAV/VNAV, the vertical and lateral integrity flags are out of view, and guidance displays show the deviations from track in vertical and lateral dimensions. The linear vertical scale limits of the VDI for LNAV/VNAV and LPV approaches are shown in Figure 7-12. **Error! Reference source not found.**

7.11.2. Alerting Scheme for LPV/LP Procedures

During normal operation in with FMS source of navigation guidance, when an LPV or LP procedure has been entered into the active flight plan and

the EFIS is in LPV or LP, the vertical and lateral integrity flags are out of view (only lateral integrity flag for LP). Additionally, the guidance displays show the deviations from track in vertical and lateral dimensions (only lateral for LP).

NOTE:

The sensitivity change from $\pm 0.3\text{NM}$ to $\pm 1\text{NM}$ can take as long as 30 seconds to provide a smooth transition for autopilots.

The linear lateral scale limits of the CDI for LNAV approach procedure.

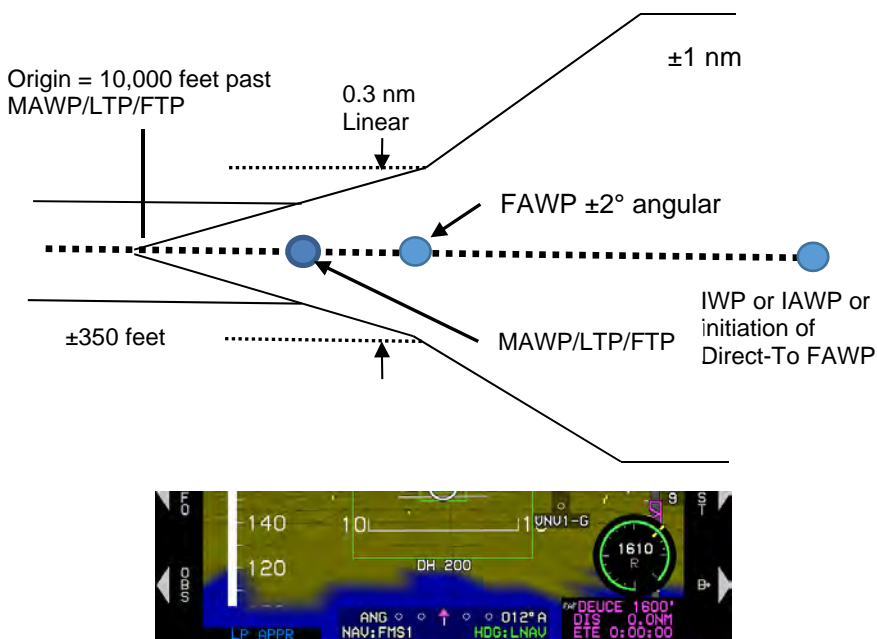

Figure 7-13: FSD Lateral Deviation Indicator Linear Deviation (not VTF Approach)

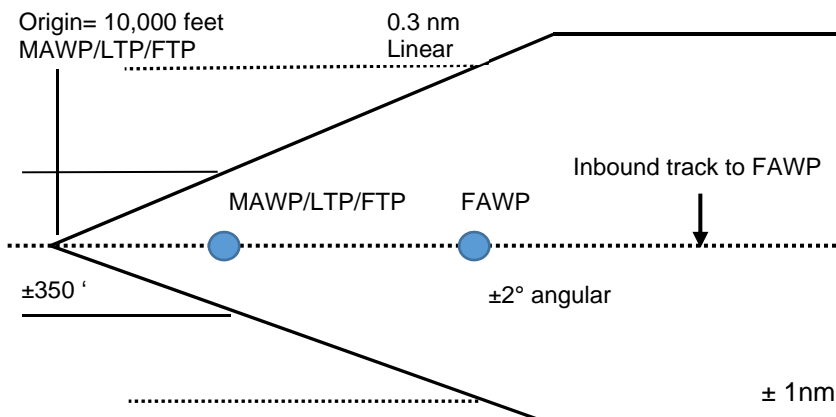

Figure 7-14: FSD Lateral Deviation Indicator Linear Deviation VTF Approach

NOTE:

Non-Numeric Cross-Track Deviation

The full-scale deflection for LNAV is either identical to LNAV/VNAV or one of the following:

Angular deviations

- 1) If a VTF approach has not been selected:
 - a) Prior to 2NM from the FAWP, the FSD is ± 1 NM
 - b) Between 2NM from the FAWP and the FAWP, the FSD is gradually changed to the FSD specified in c) below at the FAWP;
 - c) At and beyond the FAWP, but before initiating a missed approach, the FSD is the minimum of; constant FSD of ± 0.3 NM; or angular FSD defined by a $\pm 2.0^\circ$ wedge with origin located 10,000 feet past the MAWP. The FSD continues to decrease or reach a minimum of ± 350 feet.
- 2) If a VTF has been selected:
 - a) The FSD is the minimum of; constant FSD of ± 1 NM; or angular FSD defined by a $\pm 2.0^\circ$ wedge with origin located 10,000 feet past the MAWP. The FSD continues to decrease or reach a minimum of ± 350 feet.

7.12. Approach Type Selection

The EFIS selects the approach type (LNAV, LNAV/VNAV, LP, or LPV) when entering approach mode with the following order of precedence and prerequisites:

- 1) **LPV:**
 - a) LPV Enable is enabled;
 - b) ARINC-424 “Level of Service” indicates LPV minimums are published;
 - c) Valid long-term, fast, and ionospheric SBAS corrections are available and being applied to at least 4 GPS satellites;
 - d) Final approach segment data block exists and passes the built-in-test; and
 - e) Horizontal and vertical alert limits from final approach segment data block are predicted to be supported.
- 2) **LP:** (Same precedence and prerequisites as **LPV** (except ARINC-424 “Level of Service” indicates LP minimums are published.)
- 3) **LNAV/VNAV:**
 - a) ARINC-424 “Level of Service” indicates LNAV/VNAV minimums are published;
 - b) If a final approach segment data block exists, it passes built-in-test; and
 - c) Horizontal alert limit of 556m (.3NM) is predicted to be supported.

NOTE:

Because the EFIS inherently supports barometric VNAV, it is not a prerequisite for the vertical alert limit to be predicted or supported, nor is it a prerequisite for valid long-term, fast, and ionospheric SBAS corrections to be available and applied to at least four GPS satellites. Rather, the vertical alert limit (50m) and SBAS correction tests are used to determine whether to present guidance based upon GPS altitude or barometric altitude.

- 4) **LNAV:** Default approach type selected when none of the above selections are made. There are no prerequisites for selecting LNAV.

The EFIS continuously displays the approach type (mode indication) after selection. The EFIS does not degrade the approach type after selection unless the approach procedure is reselected or changed.

NOTE:

These are GPS/SBAS modes and still appear during a ground based approach such as an ILS approach.

Some instrument procedures include notes saying the following: “RNP 0.3 required” and are coded as an RNAV procedure. In these cases, select manual RNP to see the RNP and ANP values on the PFD.

7.12.1. Approach Path Definition (GPS Procedures)

Normal IAP path definitions are as specified in the procedure contained in the navigation database and FAS data block. Deviations are provided with respect to the active leg of the approach procedure. The final approach path is defined by: the Flight Path Alignment Point (FPAP), Landing Threshold Point/Fictitious Threshold Point (LTP/FTP), and Threshold Crossing Height (TCH) and glidepath angle.

NOTE:

The threshold location is referred to as the LTP if it is co-located with the runway and FTP if it is displaced from the runway. The glidepath angle is defined relative to the local tangent plane of the WGS-84 ellipsoid. This path definition is designed to mimic ILS glideslope characteristics, where the virtual glidepath antenna location is offset from the runway by less than 500 feet.

7.12.2. VTF IFR Approach

In addition, the pilot may select a VTF IFR approach, indicating the pilot does not intend to fly the entire procedure. When a VTF IFR approach is selected, the EFIS creates an initial point (IP) waypoint on the extended final approach course to provide deviations relative to the extended final approach course. The IP is a fly-over defined exit heading waypoint, and the leg prior to the IP is designated a discontinuity. Until the FAWP is sequenced, the EFIS indicates a VTF IFR approach has been selected. **VECTORS** indicates guidance is not relative to a published approach path, and TERPS clearances are not assured.

7.12.3. VTF VFR Approach



Figure 7-15: VTF VFR Approach

The pilot may select a VFR approach to a runway or user waypoint with a defined approach bearing. When a VFR approach is selected, the EFIS creates an “IP” waypoint approximately 12 NM on the extended final approach course to provide deviations relative to the extended final approach course. The IP is designated a fly-over defined exit heading waypoint, and the leg prior to the IP is designated a discontinuity.

As depicted in Figure 7-15, during the VTF VFR approach, the aircraft proceeds towards the IP. Since the IP is designated as a discontinuity, proceeding direct is not possible. When attempting to proceed direct to the IP, only the active leg between the IP and RW25 is activated.

7.13. Loss of Navigation Monitoring

The EFIS continuously monitors for loss of navigation capability. In manual or automatic RNP mode prior to sequencing the FAWP, the LON caution is displayed with a 10-second time to alert the RNP value is less than 2NM and a 30-second time to alert otherwise. RNP is also a statement of navigation performance necessary for operation within a defined airspace.

7.13.1. Automatic RNP Mode

In automatic RNP mode, after sequencing the FAWP, the EFIS indicates when the navigation system is no longer adequate to conduct or continue the approach by displaying the LON condition inside the CDI on the transmit enabled display. The flag is latched until no longer in an approach mode.

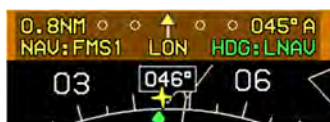

Figure 7-16: LON Indication

NOTE:

The EFIS is capable for the following individual levels of RNP but may not be capable due to limited satellite coverage. Manual RNP is selectable between 0.10NM and 15NM as follows:

- 1) 0.01 NM increments between RNP 0.10 and RNP 0.3
- 2) 0.1 NM increments between RNP 0.3 and RNP 2
- 3) 1 NM increments between RNP 2 and RNP 15

7.13.2. Faults Menu

Use the faults menu to distinguish the cause of a LON caution. Table 7-11 explains conditions and caution termination for each mode of flight.

Table 7-11: Summary of Faults Menu

Mode of Flight	Conditions	Caution Termination
Manual RNP RNP: 0.10M RNP: 15.0M	LON displayed with a 10-second time to alert if RNP value is less than 2NM and a 30-second time to alert.	Returns to normal state immediately upon termination of responsible condition
Automatic RNP RNP: 0.10A RNP: 15.0A	After sequencing the FAWP, LON displayed when navigation system is no longer is adequate to conduct or continue the approach.	Latched until equipment no longer in an approach mode.
Enroute and Terminal TERMINAL	LON displayed when navigation system is no longer is adequate to conduct or continue the navigation.	Returns to normal state immediately upon termination of responsible condition
LNAV Approach mode	Upon passing the FAWP, flag is latched until EFIS is	Returns to normal state immediately upon

Table 7-11: Summary of Faults Menu

Mode of Flight	Conditions	Caution Termination
LNAV APPR	no longer in an approach mode.	termination of responsible condition
LNAV/VNAV Approach mode	LON displayed when navigation system is no longer adequate to conduct or continue the approach.	After sequencing the FAWP, LON/VERT LON flags are latched until the equipment is no longer in an approach mode. As defined above with the exception that when the LNAV/VNAV approach mode is predicted upon Barometric VNAV. (See Note1)
LNU/UNU APPR		
LP or LPV Approach mode	LON or VERT LON displayed when navigation system is no longer adequate to conduct or continue the approach.	Prior to sequencing the FAWP, flags return to normal state immediately upon termination of the responsible condition.
LP APPR		
LPU APPR		
Note 1: A supplemental test is added for lateral and vertical flagging. A supplemental test is added for vertical flagging when barometric altitude information is in a failed state.		

7.13.3. Loss of Integrity Caution Monitoring

The EFIS provides a caution, independent of any operator action, when the equipment has a loss of integrity monitoring. When HPL (Horizontal Protection Level) exceeds the applicable HAL (Horizontal Alert Limit) for the longer than applicable time to alert and HPL_{SBAS} exceeds the HAL for the current navigation mode for longer than 2 seconds. There are two types of HPL, HPL_{FD} , or HPL_{SBAS} but only one transmitted by the receiver as valid at any time.

Table 7-12: Loss of Integrity Caution Monitoring

Mode of Flight	HAL	Time to Alert
RNP: 0.10A RNP: 15.0A (See Note 1)	As manually set or automatically retrieved	10 Seconds (RNP<2NM) 30 Seconds (otherwise)
Enroute	2 NM	30 Seconds

Table 7-12: Loss of Integrity Caution Monitoring

Mode of Flight	HAL	Time to Alert
TERMINAL	1 NM	10 Seconds
LNAV APPR	0.3 NM	10 Seconds
LNU/UNU APPR	0.3 NM	10 Seconds
LP APPR	0.3 NM	10 Seconds
LPU APPR		
Departure	0.3 NM	10 Seconds

Note 1: Only applicable prior to sequencing FAWP. Meeting loss of integrity criteria after sequencing the FAWP is defined as LON.

7.14. Manual Holding Patterns

Most waypoints within an active flight plan can have a manual holding pattern created with the following parameters:

- 1) Inbound course to the holding fix with 1° increments relative to magnetic or true north.
- 2) A left or right turn direction.
- 3) A turn distance, settable in either time (increments of 0.1 minutes from 0.5 minutes to 5.0 minutes) or distance (increments of 1 nautical mile from 1 nautical mile to 25 nautical miles). When a time setting is used, the speed used to calculate distance is the holding speed set in EFIS limits.

7.15. Selection of an Instrument Procedure

When an instrument procedure is selected and active, the receiver notifies the pilot of the most accurate level of service supported by the combination of the GPS/SBAS signal, receiver, and selected approach using naming conventions on the minima lines of the selected approach procedure. Once the level of service has been given, the EFIS operates in this mode for the duration of the procedure, unless the level of service is unavailable. The EFIS cannot change back to a more accurate level of service until the next time an approach is activated. The following are samples of step-by-step procedures:

- 1) Standard Instrument Departure (DP)
- 2) Standard Terminal Arrival Route (STAR)
- 3) ILS Instrument Approach
- 4) ILS Instrument Approach with Manual Termination Leg
- 5) LOC Back Course Instrument Approach
- 6) RNAV (GPS) Instrument Approach to LP Minima
- 7) RNAV (GPS) Instrument Approach to LPV Minima
- 8) RNAV (RNP) Instrument Approach to RNP 0.11 DA
- 9) NRST ILS Instrument Approach
- 10) VOR/DME Instrument Approach
- 11) LDA Y RWY 19 Instrument Approach to Circling Minima
- 12) ILS or LOC RWY 1 Instrument Approach with Missed Approach Flown to Alternate Fix

7.15.1. Missed Approach and Departure Path Definition

Once on the final approach segment, the pilot may initiate an immediate missed approach or arm the system to execute the missed approach at the MAWP. If armed before crossing the MAWP, the equipment arms the missed approach for automatic initiation at the MAWP. If a missed approach is not initiated prior to crossing the MAWP, the EFIS switches to FROM mode at the MAWP and continues on the same course.

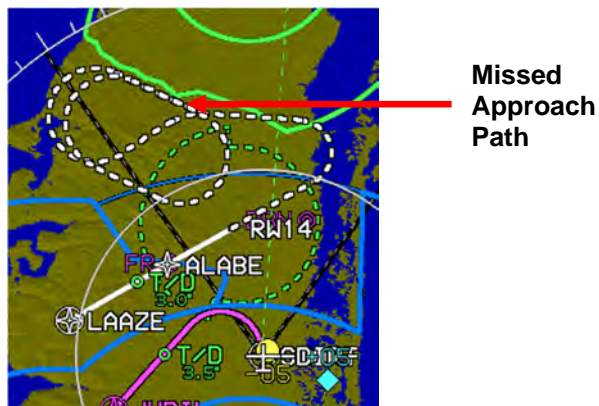

Figure 7-17: Missed Approach and Departure Path

If the pilot initiates the missed approach, the EFIS provides guidance relative to the procedure. If a missed approach is armed prior to crossing the MAWP, the desired path to and after the MAWP is defined by the procedure. If the first leg in the missed approach procedure is not a straight path aligned within 3° of the final approach course, the FSD changes to terminal mode FSD (± 1 NM) when the missed approach is initiated. Otherwise, the FSD changes to ± 0.3 NM when the missed approach is initiated (departure mode) and changes to terminal mode FSD (± 1 NM) at the turn initiation point of the first waypoint in the missed approach procedure.

The pilot may select DP guidance and, if the first leg in the DP is not a straight path aligned within 3° of the runway heading, terminal mode FSD (± 1 NM) is used. Otherwise, the FSD is ± 0.3 NM (departure mode) and changes to terminal mode FSD (± 1 NM) at the turn initiation point of the first waypoint in the DP.

7.15.2. Standard Instrument Departure (DP) (Step-By-Step)

The following example includes the execution of a Standard Instrument Departure procedure from John Wayne-Orange County, California (KSNA) with radar vectors to the assigned route. This procedure includes blue numbers to associate places of reference on the chart and the EFIS.

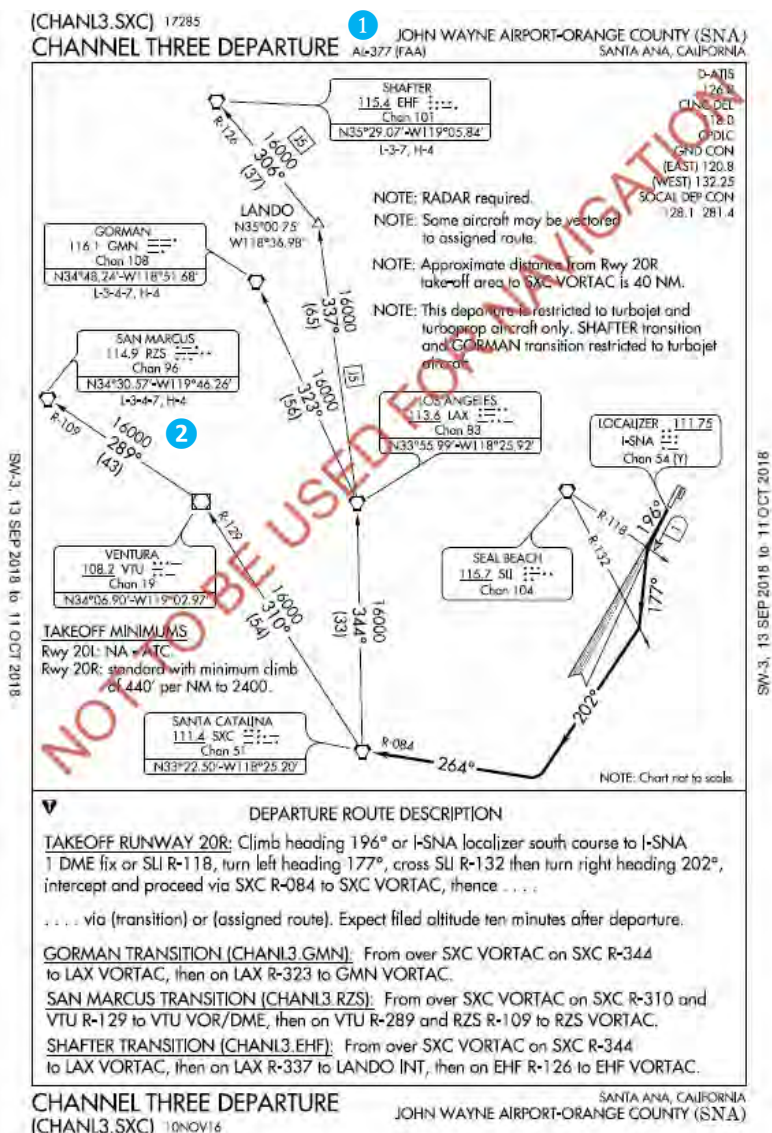

Figure 7-18: Standard Instrument Departure (DP)



1) Press **ACTV (L2)** departure airport must be entered as a waypoint.

2) **1** Rotate **1** to desired airport (KSNA) and push to enter.



3) Rotate **1** to **DP..** and push to enter.



4) **1** Rotate **1** to desired DP (CHANL3). Push to enter.



5) **2** Rotate **1** to desired transition (RZS). Push to enter.



6) ATC issues radar vectors to assigned route as published in the DP text notes.

7) Push **1** and rotate to **NAV LOG** and push to enter to view first portion and then rotate **1** to view remainder of NAV LOG.

WAYPOINT	UNAV/OFFSET	PRTH	DIST	ETE	ETA	FUEL
KSNA						
RW20R	92°	E-136°	0.5mi	0:00		
*-RAD-	92°	E-177°	3.8mi	0:10	15:09	3614
*-RAD-	92°	E-202°	16.3mi	0:05	15:10	3610
*-INT-	92°	E-255°	16.3mi	0:05	15:16	3584
BKC	92°	E-289°	16.3mi	0:16	15:21	3562
UTU	92°	E-310°	54.3mi	0:16	15:27	3487
RZS	92°	E-289°	16.3mi	0:16	15:40	3462
KONT	92°	E-03°	110mi	0:33	16:24	3218
KPSP	92°	E-032°	66.1mi	0:17	16:21	3158
KPHX	92°	E-082°	225mi	1:08	17:50	2896

7.15.3. Standard Terminal Arrival Route (STAR) (Step-By-Step)

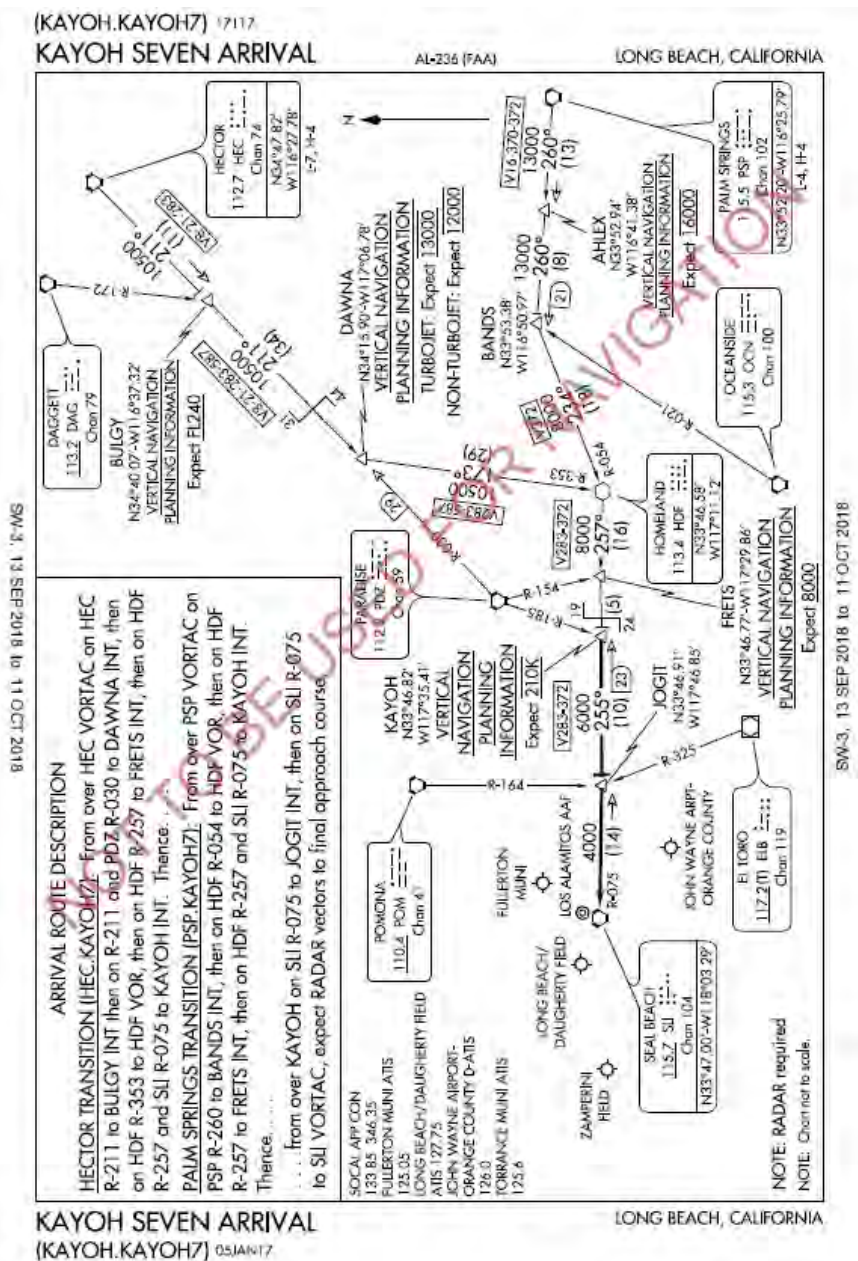
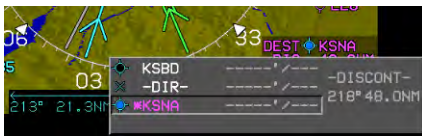

Figure 7-19: Standard Terminal Arrival Route (STAR)

If the selected waypoint is an airport with a published STAR, this option is available from a selection list of available STARS, transitions, and runways. After selection, the appropriate STAR is created and displayed on the MAP page. Activating a STAR deletes any pre-existing STAR, and it is inserted prior to any approach waypoints if previously entered.

STARS normally terminate at a fix near the airport, so a radar vector or feeder route is used for transition to the approach phase of the arrival. If an Instrument approach is activated during the STAR, the approach waypoints are inserted after the STAR.

The following example includes the execution of a STAR procedure into John Wayne Airport-Orange County, California (KSNA) followed by an ILS RWY 20R.



1) Press **ACTV (L2)** arrival airport must be entered as a waypoint.

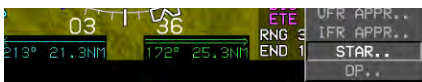

2) Rotate **1** to desired airport (KSNA) and push to enter.

3) Rotate **1** to **STAR..** and push to enter.

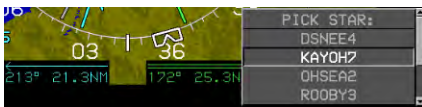

4) Rotate **1** to desired STAR (KAYOH7). Push to enter.

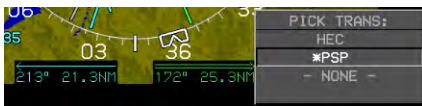

5) Rotate **1** to desired transition (*PSP) push to enter. (* indicates most likely transition based on arrival area and track.)

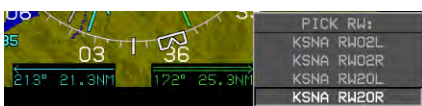

6) Rotate **1** to desired RWY and push to enter.



WAYPOINT	UNAV/OFFSET	PATH	DIST	ETE	ETA	FUEL
KSBD		H	389	41.0m	01:10	15:44
PSP		E	280	16.3m	01:03	15:40
AHLEX		D	100	10.0m	01:00	15:35
DIR		D	120	22.5m	01:05	15:40
BANDS		E	250	16.5m	01:05	15:44
HDF		E	250	16.5m	01:05	15:48
FRETS		E	250	4.6m	01:01	15:48
KAYOH		E	250	9.5m	01:02	15:51
JOOIT		E	250	13.0m	01:03	15:55
SLI		E	250	10.0m	01:03	15:57
KSNA						15:57

7) Push **1** and rotate to **NAV LOG** and push to enter.

8) ATC clears direct to BANDS. Press **ACTV (L2)**. Rotate **1** to **BANDS** and then press **DP (R4)** and push to enter.

9) Flight is now on the STAR route with the next waypoint HDF.

7.15.4. ILS Instrument Approach (Step-By-Step)

All approach operations begin with the same basic steps. This example selects ILS or LOC RWY 20R at John Wayne-Orange County, California (KSNA). This procedure includes blue numbers to associate places of reference on the chart and the EFIS.

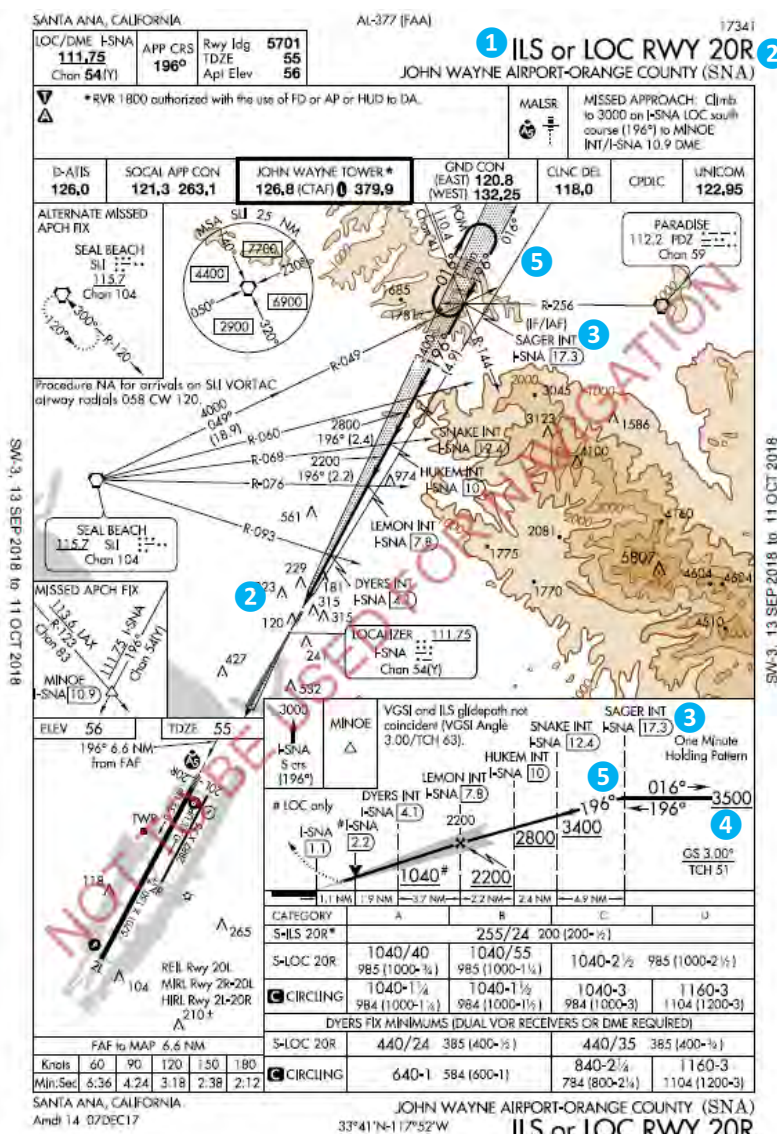

Figure 7-20: ILS Instrument Approach (KSNA)



- 1 With destination airport entered as the waypoint, press **ACTV (L2)**. Rotate **1** to desired airport and push to enter.



- 2 After reselecting the MAP page continue creating the ILS approach for KRNA.

- 3 Rotate **1** and select **IFR APPR..** and push to enter.



- 4 Rotate **1** to desired approach. Push to enter.



- 5 Rotate **1** to transition (*SAGER) (* indicates most logical from current position). Push to enter.



- 6 Rotate **1** to landing runway. Push to enter. (Colors the active runway light gray.)



- 7 ATC issued clearance direct to SAGER. With the active flight plan open, rotate **1** to **SAGER** **3**, press **R4** and then push to enter.



- 8 **WAYPOINT** is at the top of the list and automatically highlighted. Push **1** to select this ATC cleared intersection as a waypoint to be flown to directly.



- 9) 4 Approaching the top of descent, the VDI appears with VNV1-B source as the flight plans on crossing SAGER at 3,500' MSL.



- 10) ATC advises cleared direct SAGER expect no holding maintain 3,500' until established on the localizer, cleared for the ILS 20R.
- 11) Press **ACTV (L2)** and then rotate **1** to the second **SAGER** and push to enter.
- 12) This process clears the preceding white course lines providing clearer MAP of navigation symbology.



13) Approaching SAGER with good vertical performance indicating no pilot action necessary to cross SAGER at 3,500'. The green arc altitude predictor showing bottom of descent at SAGER.

14) **5** Press **VLOC1 (L3)**. Rotate **1** to **196°** and push to enter. Observe CDI to verify.



NOTE:

Automatic navigation source switching only occurs during NRST ILS procedures before passing the FAF.

Automatic navigation source always switches back to FMS upon passing the MAWPT on all ILS/LOC, NDB, and VOR approaches.



15) Approaching SAGER as a fly-by waypoint with a normal turn defined entry and exit legs. Push **1** and rotate to **HSI** and push to enter.



- 16) After passing LEMON FAF and outer marker, lateral and vertical autopilot modes are captured (green color), and auto waypoint sequencing is suspended until miss approach procedure is armed by pressing **ARM (L6)**.



- 17) Over the middle marker and with zoom mode active, press **MENU (R1)** and then **ZOOM (R3)** to emulate the outside view in the PFI area. Above the glideslope with landing gear extended.

7.15.5. ILS Approach with Manual Termination Leg in MAP (Step-By-Step)

This example selects RAF Cranwell United Kingdom (EGYD) with -ALT- termination leg followed by an immediate manual termination leg requiring pilot action to resume automatic waypoint sequencing. This procedure includes blue numbers to associate places of reference on the chart and the EFIS.

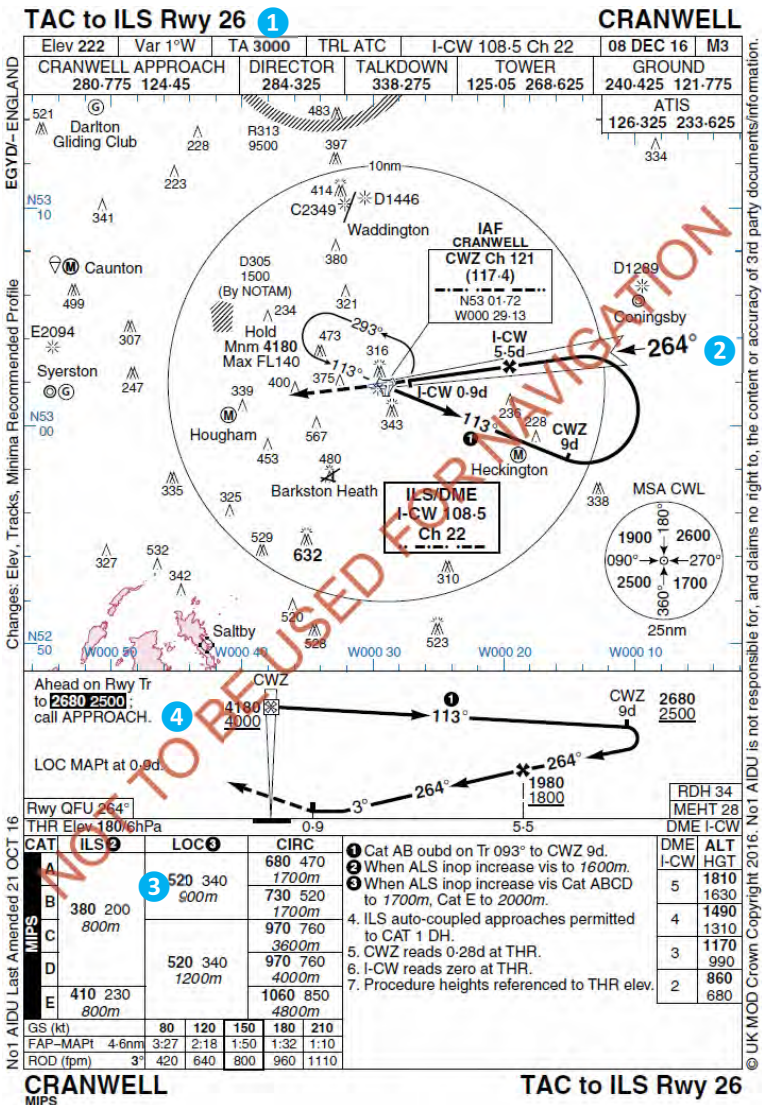
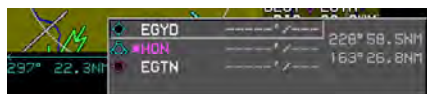

Figure 7-21: ILS Approach (EGYD)



- 1) Press **ACTV (L2)**. Rotate **1** to the destination airport and push to enter.



- 2) Rotate **1** to **IFR APPR..** and push to enter.



- 3) Rotate **1** to desired approach and push to enter.

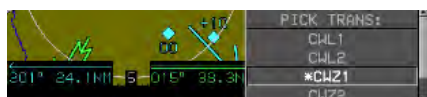

- 4) Rotate **1** to desired transition and push to enter. (* indicates most logical from current position)

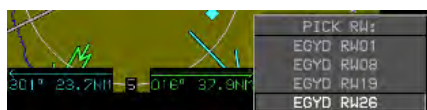

- 5) **1** Rotate **1** to desired runway and push to enter. (Colors the active runway light gray).



- 6) Press **ACTIVE (L2)**. Rotate **1** to FI26 (FAF) and push to enter.
- 7) **2** Press **VLOC1 (L3)** and rotate **1** to the published final approach course 264° and push to enter.



Observe CDI to verify. NAV:BC1 is present until aircraft heading is within 105° of FAC.

NOTE:

Automatic navigation source switching only occurs during NRST ILS procedures before passing the FAF.

Automatic navigation source switching back to FMS always occurs upon passing the MAWPT on all ILS/LOC and VOR approaches.



- 8) 3 Localizer minimums set as MDA 520' with the landing gear down.
- 9) Autopilot captured both lateral and vertical modes established on glideslope.
- 10) **ARM (L6)** was pressed and now the waypoint sequencing has resumed.



- 11) ATC has cleared the flight for low approach only. To begin missed approach procedure before passing the MAWPT, press **MISS (L5)**.



- 12) ④ Past the MAWP, auto nav source switches to FMS-1. -ALT- leg climbing to 2680' with green altitude predictor arc indicating climb performance achieves leg requirement.
- 13) It is important to note there is no further navigation guidance beyond the ALT termination leg.



- 14) Automatic waypoint sequencing suspended and ready for pilot action to press **RESUME (L6)**.



- 15) After **RESUME (L6)** is pressed, normal waypoint sequencing resumes, course to next active waypoint appears as a magenta line, and active waypoint information is updated.

7.15.6. LOC Back Course Instrument Approach (Step-By-Step)

This example includes a VTF LOC/DME Back Course approach at Santa Maria CA USA (KSMX) with attention drawn to OBS settings and includes blue numbers to associate places of reference on the chart and the EFIS.

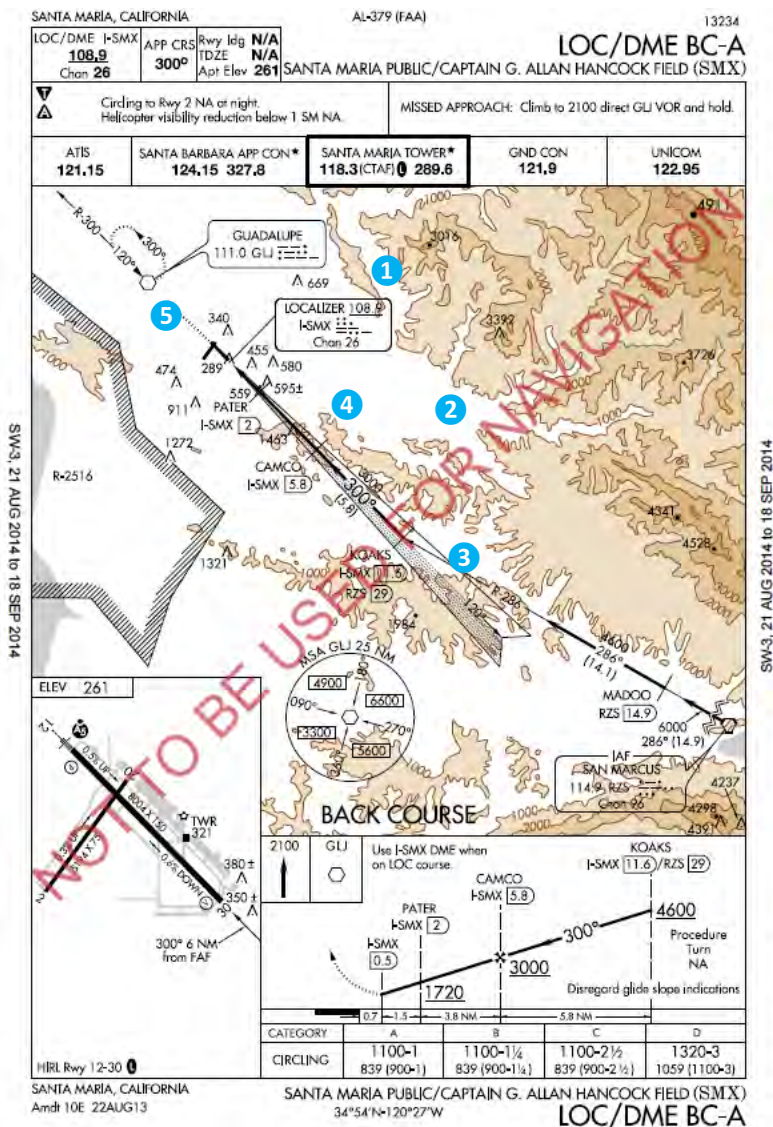

Figure 7-22: LOC Back Course Approach



- 1) ① Press **ACTV (L2)**. Rotate ① to airport active waypoint. Push to enter.



- 2) Rotate ① to **IFR APPR..** and push to enter.



- 3) Rotate ① to desired approach (**LBCA**) and push to enter.

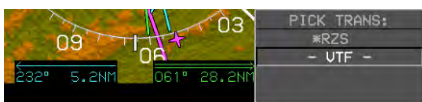

- 4) Rotate ① to transition (*indicates most logical from current position) or **- VTF -** for vectors to final. Push to enter.

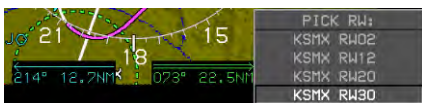

- 5) Rotate ① to desired runway. Push to enter.

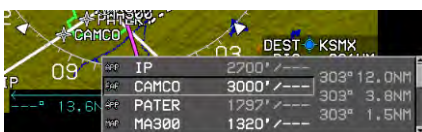

- 6) ② Assume ATC issued clearance to fly heading 095° for radar vectors to CAMCO, press **ACTV (L2)**, and then **Ⓜ (R4)** when CAMCO is highlighted. Push ① to enter.

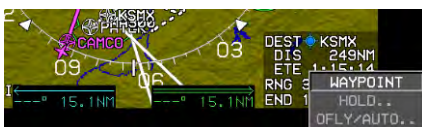

- 7) It is only desired to cross CAMCO as a waypoint. Push ① to enter.





- 8) ATC issues radar vectors to fly heading 080° to CAMCO maintain 3,300'.



- 9) To set minimum altitude, press **MENU (R1)**, **BUGS (R2)**, **MINS (R3)**, and then rotate **1** to **MIN ALT..** and push to enter. Rotate **1** to **1100** and push to enter.

- 10) **3** Assume ATC has issued a clearance cleared for the LOC back course RWY 30 maintain 4,600' until passing CAMCO. Press **OBS (L4)**. Rotate **1** to approach course setting of 300° to avoid reverse sensing indications of CDI and push to enter or press **EXIT (R1)**.



- 11) ATC issues clearance to fly heading 115° maintain 3,000' and expect localizer back course runway 30.



- 12) In preparation for the approach, press **ACTV (L2)**, rotate **1** to **PATER**, and push to enter.

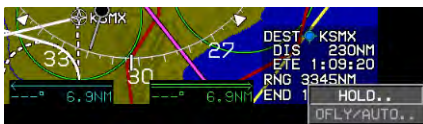

- 13) Since it is not desired to HOLD or alter the waypoint characteristics for PATER, press **EXIT (R1)** to exit the menu.



- 14) ATC issues clearance to fly direct to CAMCO and cleared for the LOC Back course RWY 30 KSMX.

- 15) Press **ACTV (R2)**, rotate **1** to **CAMCO**, press **ENT (R4)**, and push **1** to enter.



- 16) Push **1** to enter to use CAMCO as the FAF waypoint and not to HOLD or alter waypoint characteristics.



- 17) Press **LNAV (L5)** for one touch change to Heading BUG sub-mode of LNAV.



NOTE:

- Localizer CDI is alive and moving off full scale from the right.



- 18) **4** After passing the FAF (CAMCO), **MISS (L5)** and **ARM (L6)** appear but, in this case there is no **SUSPEND** advisory due to the stepdown fix of PATER 2.9NM ahead.



19) Approaching PATER (fly-by waypoint symbol) stepdown fix without the missed approach procedure armed. The green arc altitude predictor indicates arrival at minima over the runway.



20) Passing the MAWP, nav source automatically switches to FMS, and CDI changes cyan to magenta.



- 21) **5 CONT (L6)** appears as a reminder to press when ready to leave the hold and continue to the destination (KSMX).

7.15.7. RNAV (GPS) Instrument Approach to LP Minima (Step-By-Step)

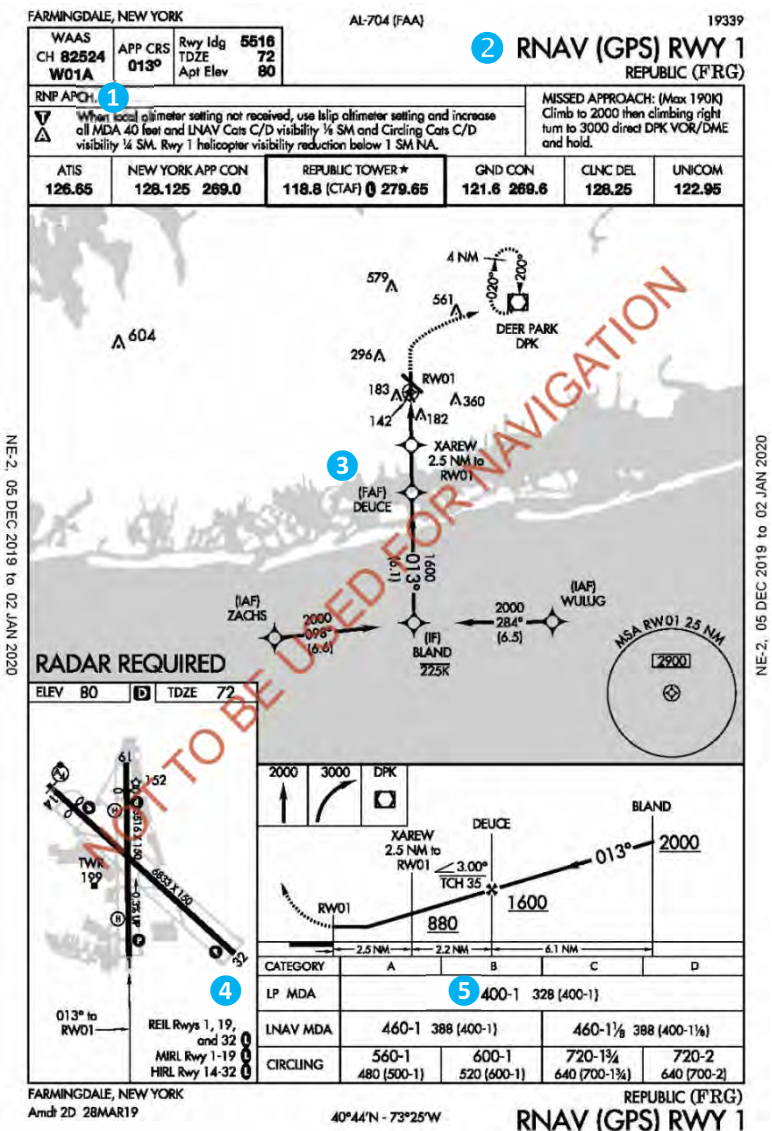

Figure 7-23: RNAV (GPS) Instrument Approach to LP Minima

This example includes a RNAV (GPS) RWY 1 Republic (KFRG) to LP minima with VTF to DEUCE intersection and includes blue numbers to associate places of reference on the chart and the EFIS.



- 1) Press **ACTV (L2)**. Rotate **1** to airport active waypoint. Push to enter.



- 2) Rotate **1** to **IFR APPR..** and push to enter.



- 3) **1** Rotate **1** to Desired instrument approach with matching 5-digit channel number from instrument approach chart and push to enter



- 4) Rotate **1** to **- VTF -** and push to enter.



- 5) **2** Rotate **1** to assigned runway for landing and push to enter. (Colors RW01 light gray.)



- 6) ATC issues radar vector to fly 090° for DEUCE (FAF) and maintain 3,500'.
- 7) During creation of the VTF approach, an IP on the extended centerline is created and terminates at the FAF. During this radar vector, there is no magenta line or HITS guidance.

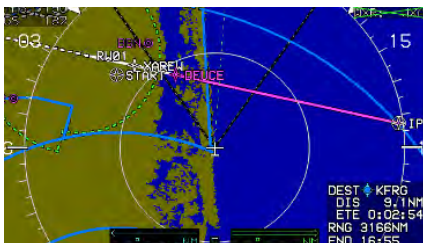

- 8) ATC now issues clearance for the RNAV (GPS) RWY1 approach.
- 9) **3** Press **ACTV (L2)**, rotate **1** to **DEUCE**, press **D** (**R4**), and then push **1** to enter.



- 10) Push **1** to enter since it is only desired to pass the FAF as a waypoint and continue waypoint sequencing throughout the approach. This leg is descending on VNV1-B source information to DEUCE.



- 11) Press **LNAV (L5)** for one touch changing of heading sub-mode to LNAV.



- 12) **4** Approaching DEUCE, VDI source of information is VNV1-G and GPS mode is **LP APPR**.



- 13) Inside the FAF, press **ARM (L6)** now or wait until passing XAREW, the step-down-fix. Waypoint sequencing is not suspended at this point.
- 14) **5** Minimums are set to 400' DA.



- 15) Press **MENU (R1)** then **ZOOM (R3)** to change PFI area to 35° FOV.
- 16) On glidepath according to the VDI and the green arc altitude predictor on the map is over the approach end of the runway indicating no pilot action necessary to meet vertical requirements for this procedure.



- 17) Missed approach executed, landing gear retracted, press **MENU (R1)** and then **ZOOM OFF (R3)** to return PFI to wide FOV (70°).
- 18) NAV source remains FMS1, but scaling automatically switched to 0.3NM.
- 19) Active waypoint information describes the altitude termination leg ahead.

0.3NM 0 0 0 0 012° A
 NAV: FMS1 HDG: LNAV

-ALT- 2000'
 DIS 5.4NM
 ETE 0:02:25



- 20) The dynamic altitude termination leg was passed 50' low during this missed approach leg.

7.15.8. RNAV (GPS) Instrument Approach to LPV Minima (Step-By-Step)

This example includes an RNAV (GPS) RWY 32 approach to Wichita, Kansas, USA (KICT) and includes blue numbers to associate places of reference on the chart and the EFIS.

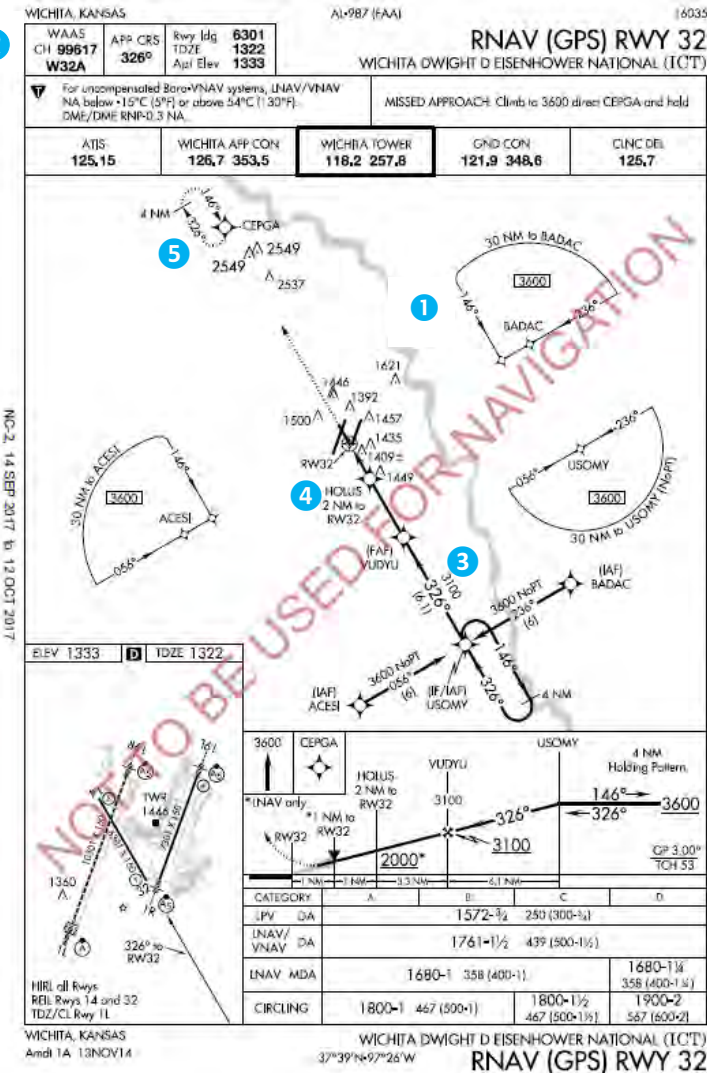

Figure 7-24: RNAV (GPS) Instrument Approach to LPV Minima



- 1) To select airport from active flight plan, press **ACTV (L2)**, rotate **1** to desired airport **1**, and push to enter.



- 2) Rotate **1** to **IFR APPR..** and push to enter.



- 3) Rotate **1** to desired approach and verify WAAS channel number **2** matches instrument approach chart and push to enter.

*RNAU32 (99617)

(* Indicates this approved procedure is fully GPS sourced. No ground nav aids are necessary.)



- 4) Rotate **1** to the desired transition and push to enter. (* indicates most logical from current position.)



- 5) Rotate **1** to assigned landing runway and push to enter. (Active runway is light gray for identification purposes.)

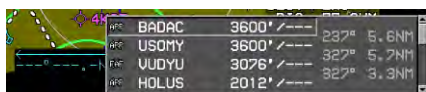

- 6) Press **ACTV (L2)**, rotate **1** to desired waypoint (BADAC) to comply with ATC clearance, press **DIR (R4)**, and then push **1** to enter a direct route with navigation guidance to BADAC.

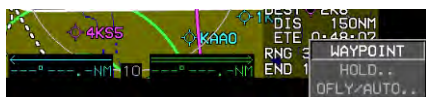

- 7) Push **1** to use BADAC as a waypoint during the direct route as entered in step 6 (this is the default option, which became highlighted).



- 12) To view the NAV LOG, push **1**, rotate to **NAV LOG** and push to enter. Rotate **1** to view the entire NAV LOG if necessary to see entire active flight plan.

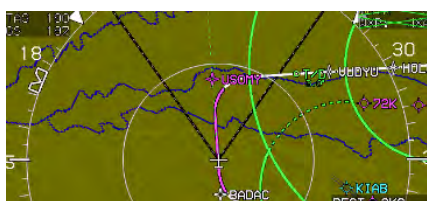

- 13) Fly-by waypoint USOMY is approached from a normal defined entry leg and exit leg.



- 14) **3** On final approach course and approaching the FAF, **LPU APPR** appears along with the VDI.



Autopilot vertical mode is coupled which is indicated by green 3.0° and LPU1.



- 15) Past VUDYU (FAF), **MISS (L5)** and **ARM (L6)** appear, but waypoint sequencing has not been suspended due to HOLUS stepdown fix ahead.



- 16) **4** Upon passing HOLUS, press **ARM (L6)** to continue auto waypoint sequencing. (This is the latest point on the approach to press **ARM (L6)**)
- 17) VDI displays vertical guidance for the LPV vertical profile based on GPS/SBAS.
- 18) Obstructions appear on PFI and map page.



- 19) Press **MENU (R1)** then **ZOOM (R3)** for wide FOV of PFI area.
- 20) FPM lined up on the active runway on glidepath approaching minimums with CDI centered and on glidepath and below minimums of 1580' MSL. "Minimums, Minimums," sounds.



- 21) Past the MAWP, NAV source remains FMS1 and scale automatically changes to 0.3NM FSD.
- 22) Press **MENU (R1)** and then **ZOOM OFF (R3)** to return PFI to wide FOV (70°).



- 23) 5 Established in hold at CEPGA. Press **CONT (L6)** to continue waypoint sequencing to next leg in active flight plan.

7.15.9. RNAV (RNP) Instrument Approach to RNP 0.11 DA (Step-By-Step)

This example includes an RNAV (RNP) RWY 19 approach to Ronald Reagan Washington National (KDCA) via radar vectors to (IAF) FERGI intersection and includes blue numbers to associate places of reference on the chart and the EFIS.

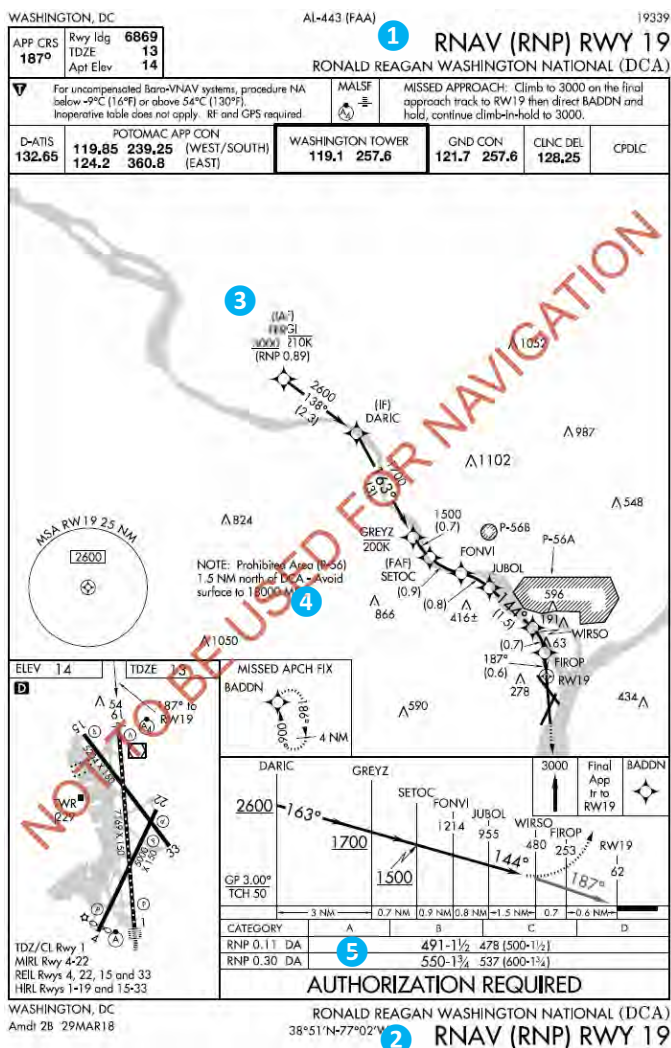

Figure 7-25: RNAV (RNP) Instrument Approach to RNP 0.11 DA



- 1) To select airport from active flight plan, press **ACTV (L2)**, rotate **1** to desired airport **1**, and push to enter.



- 2) Rotate **1** to **IFR APPR..** and push to enter.



- 3) Rotate **1** to desired approach **2** matches instrument approach chart and push to enter.



(* Indicates this approved procedure is fully GPS sourced. No ground nav aids are necessary.)



- 4) Rotate **1** to **FERGI 3** and push to enter (* indicates most logical from current position)



- 5) Rotate **1** to desired runway and push to enter.



- 6) Approaching **FERGI** with remaining flight plan in view on MAP.



- 7) Past FERGI and now on active leg to DARLIC with descent to 2,600' based on VNVB-1 and RNP status of

RNP: 1.0A
ANP: 0.1

RNP ○ ○ ○ ○ ○ 147° A
NAV: FMS1 ↑ HDG: LNAU



- 8) 5 DA minima set to 550' as aircraft approaches DARIC.



- 9) Past SETOC (FAF), press **ARM (L6)** as glidepath is maintained as per VDI.





- 10) Approaching JUBOL on glidepath and landing gear extended. Approaching DA 550'.
- 11) AFCS coupled laterally but not vertically on this procedure.
- 12) 4 Avoidance of overflying any portion of Prohibited Area (P56) is assured.

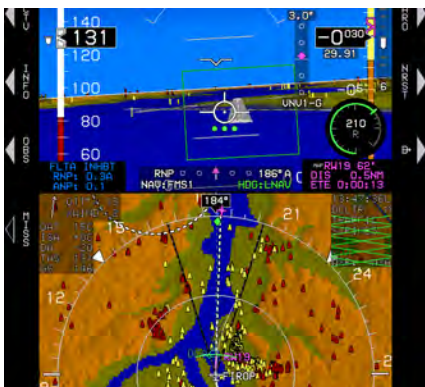

- 13) Below minima, runway insight and continue to land.
- 14) 5 This procedure required RNP 0.3 and ANP was 0.1.

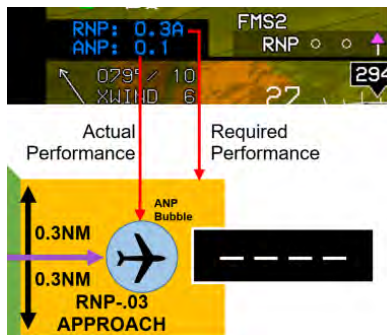

7.15.10. NRST ILS Instrument Approach (Step-By-Step)

This method does not require the airport to be in the active flight plan. This example selects ILS RWY 26R at Chino, California (KCNO) with the NRST ILS method of creation.

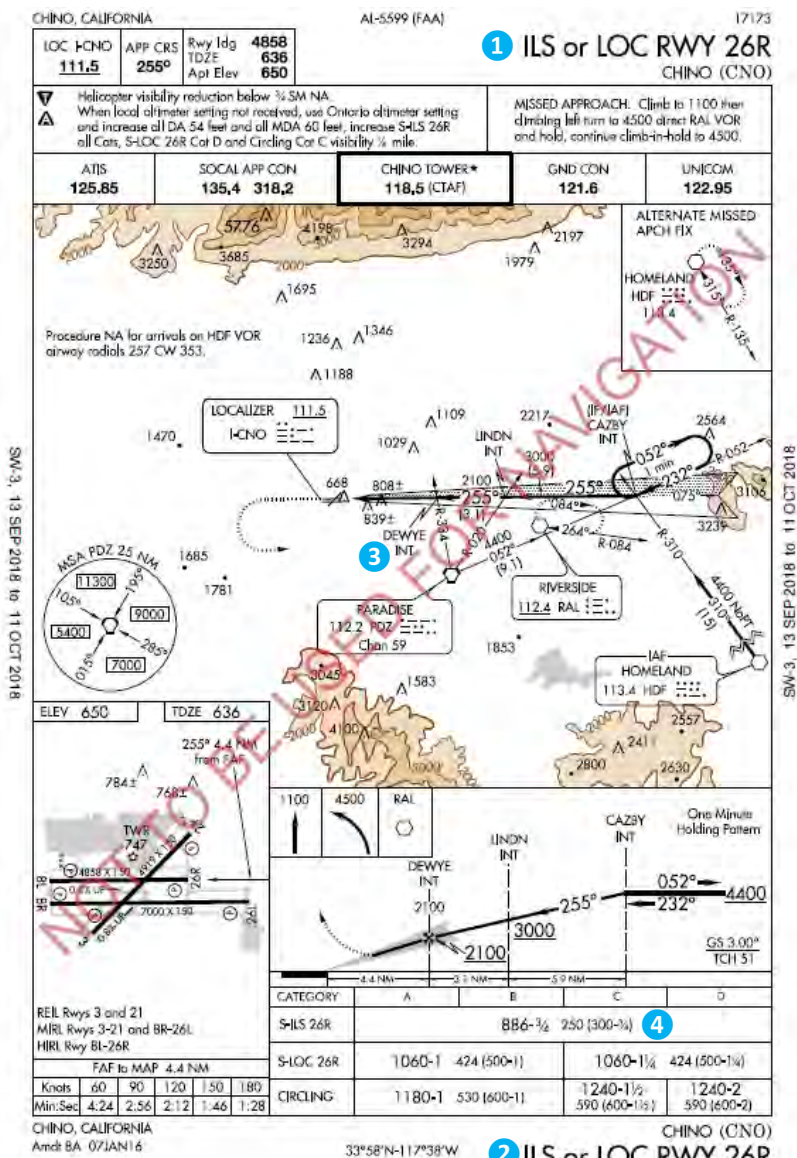
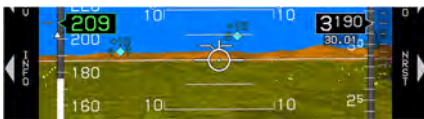

Figure 7-26: NRST ILS Instrument Approach



- 1) Press **NRST (R3)** then rotate **1** to **ILS...** Push to enter.



- 2) **1** Rotate **1** to desired ILS airport and push to enter. This action deletes previous flight plan.



- 3) **2** Once confirmed, push **1** to activate the ILS.



Following actions occur:



- a) Previous active flight plan is deleted.
- b) Flight plan to the ILS airport is created.
- c) A vectors-to-final ILS approach is activated.
- d) Heading bug is activated to the current heading.
- e) VLOC 1 and VLOC 2 OBS are set to the associated localizer course.
- f) ILS frequency is automatically transmitted to NAV#1 in standby position when system enabled.
- g) EFIS changes to LOC1, and VDI indicates source of glideslope GS1 when signal is received.



- 4) 3 DEWYE is the active waypoint, press **D** (R4) then push **1** to enter a direct route with navigation guidance to FAF.



- 5) With V_{APP} set for 125 and FD2 decluttered, the aircraft is approaching the FAF on glidepath and full-scale deflection to the left.
- 6) HSI page with VLOC1 appearing and set to 155°, and GS1 appearing on glidepath.





- 12) During the missed approach, the navigation source automatically switches to FMS1 with 0.3NM FSD. FLTA is still inhibited and terminal mode is active while within the terminal area.

7.15.11. VOR/DME Instrument Approach (Step-By-Step)

This example loads the Lamar Muni Co. USA (KLAA) VOR/DME RWY 36 approach and is flown via the east arc followed by a missed approach. Blue numbers associate locations on chart and EFIS.

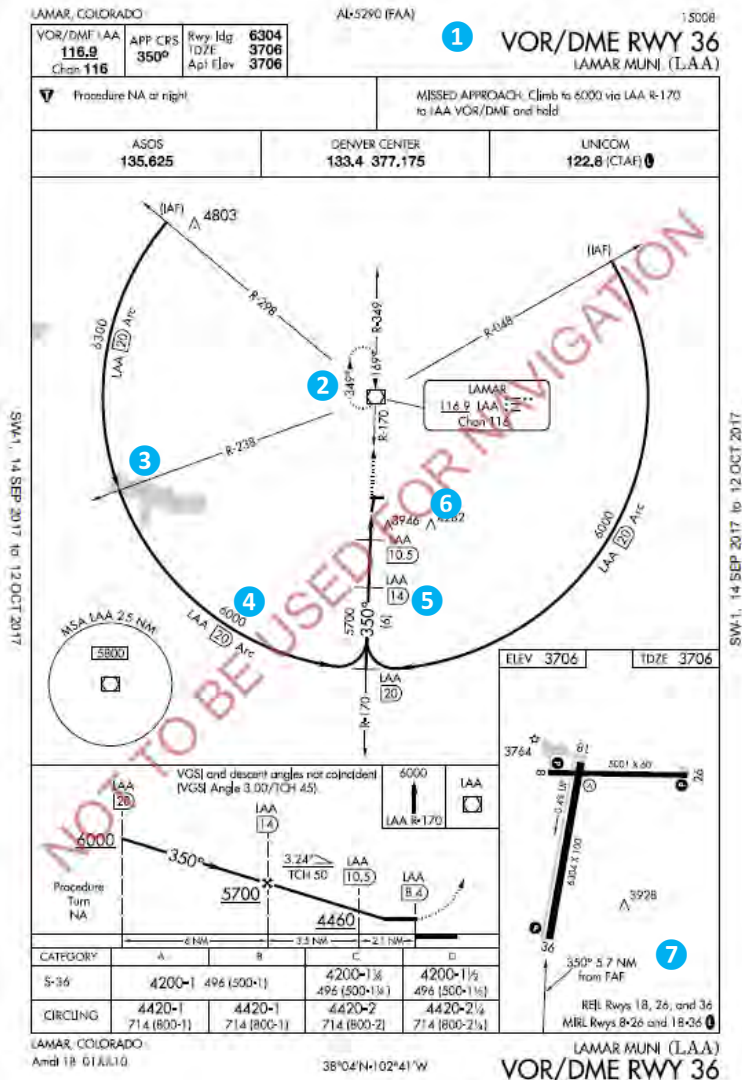

Figure 7-27: VOR/DME Instrument Approach



- 1) With destination airport highlighted as the waypoint, press **ACTV (L2)**. Rotate **1** to **IFR APPR...** Push to enter.
- 2) ATC issues clearance for the KLA A VOR/DME with D298T transition maintain 6,000 or above until established on LAA 20 DME arc.
- 3) **1** Rotate **1** to select desired approach, **VORDME36**, and push to enter.
- 4) Rotate **1** to recommended transition of D298T.
- 5) Rotate **1** to desired runway. Push to enter.
- 6) Rotate **1** to view procedure and select fix for compliance with ATC clearance **2** (D298T). Press **D** (**R4**). Push **1** to enter.



- 7) A magenta line leads from the -DIR- current position to **3** D238T, which is now the active waypoint. 6,300' is the VNAV altitude, and aircraft is in the HITS boxes, with green arc altitude predictor showing where this altitude is predicted to be reached, along the route.



- 8) D238T is a fly-by waypoint with a large turn defined exit leg.



- 9) Established on the 20 DME ARC **4** with NAV1 and NAV2 set on 116.9 MHz for LAA VOR and inbound FAC set at 350° on both VORs with DME indicating on both nav sources.
- 10) VOR1 and VOR2 RMI pointers must be displayed to overlay MAP to show OBS/DME on map page in bottom area.



- 11) Established inbound on the final approach course to the FAF (FF36) **5** crossing top of descent symbol ahead indicating when descent can be commenced to cross the FAF at 5700'. NAV Source is VOR1 and HITS source is GPS. The primary lateral source is the VOR and DME for this Instrument approach.

- 12) AFCS lateral and vertical modes are engaged.

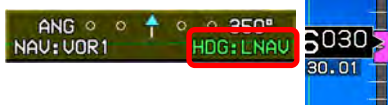

- 13) After passing the FAF, **MISS (L5)** and **ARM (L6)** appear Press **MISS (L5)** to immediately execute the missed approach procedure or **ARM (L6)** to arm the missed approach procedure upon crossing the MAWPT.
- 14) Approaching the stepdown fix **6 11VOR** at the proper altitude of 4460' as shown in the waypoint information box.



- 15) Press **MENU (R1)** then **ZOOM ON (R3)**. Established at 140 KIAS on short final with the runway in sight .6 NM ahead at the same angle as shown on the instrument approach chart.

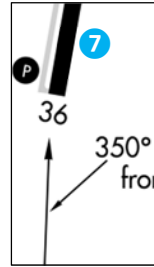

- 16) After passing the MAWPT and missed approach procedure automatically sequenced, aircraft follows dashed magenta missed approach course lines. NAV source automatically switched to FMS1 and 0.3NM FSD.

TERMINAL FLTA INHBT

refers to still being in the terminal area and TAWS terrain alerts are still inhibited.

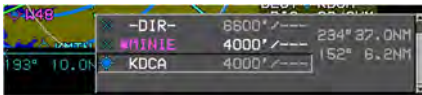

- 1) With destination airport highlighted as the waypoint, press **ACTV (L2)**.



- 2) Rotate **1** to **IFR APPR...** Push to enter.



- 3) **1** Rotate **1** to select desired approach, **LDA19-Y**, and push to enter.



- 4) **2** Rotate **1** to **- VTF -** due to ATC stating radar vectors were to be expected.



- 5) **3** Rotate **1** to desired runway. (ATC advised this is a circle to land RWY 15). Push to enter.



- 6) EFIS created an IP waypoint on extended final approach course as a fly-over with defined exit heading waypoint.

- 7) IP leg includes a top-of-descent based on current altitude.

- 8) During this leg, the pilot may prepare for using either/or both VLOC1 and VLOC2 as primary navigation sources. Press **OBS (L4)**, **NAV VLOC1 (L3)**, and then rotate **1** to **149°** and push to enter, followed by **NAV VLOC2 (L4)** and rotate **1** to **149°** and push to enter.



- 9) ATC issues radar vector heading of 290° for intercepting the LDA final approach course.

- 10) Press **HDG (L5)** and then rotate **3** to **290°** and push to enter.



- 11) 4 ATC issues clearance direct to MINIE and cleared for the LDA Y RWY 19 circle to land RWY 15. Press **ACTV (L2)**, rotate 1 to **MINIE**, press **DR** (**R4**), and then push 1 to enter.

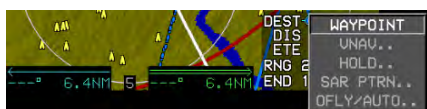

- 12) Push 1 to enter and allow EFIS to overfly MINIE as a waypoint.



- 13) After passing MINIE (FAF) 4, **MISS (L5)** and **ARM (L6)** appear. Press **ARM (L6)** to arm the missed approach to automatically sequence upon passing the MAWP.



- 14) Inside JEVGA 5, the flight is manually flown visually and RWY 15 appears as light gray ahead in the primary field of view.

7.15.13. ILS or LOC RWY 1 Instrument Approach with Missed Approach Flown to Alternate Fix (Step-By-Step)

This example loads the Akron-Canton ILS or LOC RWY 1 approach with the missed approach flown to the alternate missed approach fix (KEATN)

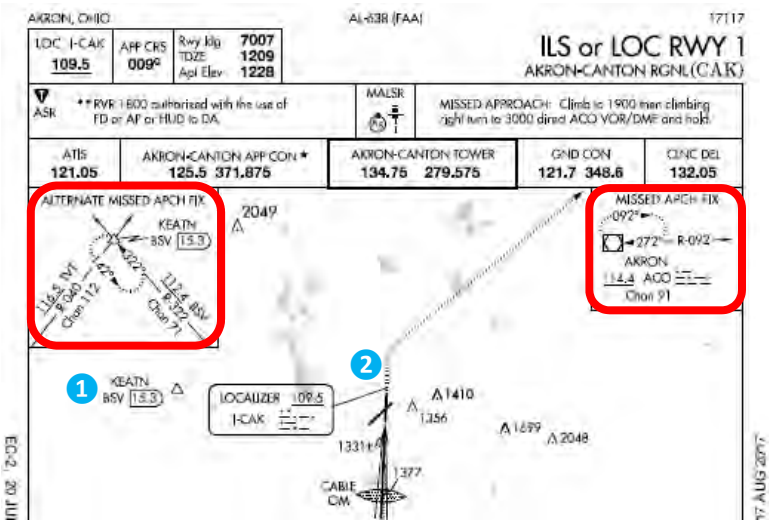
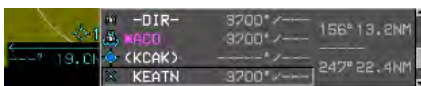

Figure 7-29: ILS or LOC RWY 1 Instrument Approach with Missed Approach Flown to Alternate fix (Step-By-Step)

During the instrument approach clearance, ATC advised that in the event of a missed approach, plan on flying the alternate missed approach instructions to **1** KEATN intersection and hold as published. The ILS RWY 1 instrument approach is loaded and the active flight plan is opened and **1** is rotated to one position past (KCAK) and **INSERT (R2)** is pressed and entered KEATN with **1** and pushed to enter.



- 1) **1** Create KEATN waypoint in active flight plan and push **1** to enter.



- 2) In active flight plan, rotate **1** to **KEATN** and push to enter.



- 3) Rotate **1** to **HOLD..** and push to enter.



- 4) Create published holding pattern at KEATN and rotate/push **1** through the process then push to enter. Observe KEATN is in correct position in active flight plan after (KCAK).



- 5) **2** Upon executing the missed approach, rotate **1** to KEATN, press **D** (R4), and then push **1** to enter a direct routing to KEATN.



- 6) Push **1** to enter and allow EFIS to overfly KEATN as a waypoint and enter holding.



- 7) Verify the active flight plan has the holding pattern entered as published and is depicted correctly.



- 8) Established in the holding pattern at KEATN. When cleared to continue to next waypoint on active flight plan, press **CONT (L6)** to resume waypoint sequencing.
- 9) If an instrument approach is necessary at the destination KMKE, the approach can be loaded without losing the holding pattern at KEATN since it was not part of the KCAK ILS 01 instrument approach procedure.



- 10) When ATC provides a clearance for an instrument approach to KMKE, it can be added without losing the holding pattern at KEATN, but the preceding ILS procedure is deleted automatically.

NOTE:

When a procedure is deleted from the flight plan, the original flight plan is correctly restored since the duplicate waypoint is only skipped and not deleted.

Navigation databases should be current for the duration of the flight. If the Aeronautical Information Regulation and Control (AIRAC) cycle is due to change during the flight, operators and pilots should establish procedures to ensure the accuracy of navigation data including suitability of navigation facilities used to define the routes and procedures for flight. Once acceptable means to compare aeronautical charts (new and old) to verify navigation fixes prior to departure, electronic data have traditionally been verified against paper products. If an amended chart is published for the procedure, do not use the database to conduct the operation.

There may be a slight difference between the navigation information portrayed on the chart and the primary navigation display heading. Differences of 3° or less may result from equipment manufacturer's application of magnetic variation and are operationally acceptable.

GPS receivers do not "fail down" to lower levels of service once the approach has been activated.



If only **LPU** appears, use the LNAV minima if the rules under which the flight is operating allow changing the type of approach being flown after commencing the procedure. If the lateral integrity limit is exceeded on an LP approach, a missed approach is necessary, since the lateral alarm limit may not be reset while the approach is active.

Section 8 Terrain Awareness Warning System

8.1. Terrain Awareness Warning System (TAWS) Functions

The IDU provides TSO-C151b TAWS functionality. The following description is for a TAWS Class A, B, and C depending on aircraft configuration and external sensors/switches. Warning functions provided by TAWS are as follows. See Section 2 System Overview for additional information on system warning, caution, and advisory alerts.

Table 8-1: TAWS Functions Provided by the EFIS

Aircraft Type	Airplane				Airplane
	RG + F	RG	FG + F	FG	
TAWS Class	A	A	A	A	B or C
Terrain Display	✓	✓	✓	✓	✓
FLTA	✓	✓	✓	✓	✓
PDA	✓	✓	✓	✓	✓
GPWS Mode 1	✓	✓	✓	✓	✓
GPWS Mode 2	✓	✓	✓	✓	
GPWS Mode 3	✓	✓	✓	✓	✓
GPWS Mode 4	✓	✓	✓		
GPWS Mode 5	✓	✓	✓	✓	
500' Call	✓	✓	✓	✓	✓

- 1) **Terrain Display:** Terrain and obstacles on PFI and Map.
- 2) **Forward Looking Terrain Awareness (FLTA):** Alerts to hazardous terrain or obstructions in front of the aircraft.
- 3) **Premature Descent Alert (PDA):** Alerts when descending well below a normal approach glidepath on the final approach segment of an instrument approach procedure.
- 4) **Excessive Rate of Descent (GPWS Mode 1):** Alerts when high rate of descent above terrain (i.e., descending into terrain).
- 5) **Excessive Closure Rate to Terrain (GPWS Mode 2):** Alerts when hazardously high rate of change over rising terrain.
- 6) **Sink Rate after Takeoff or Missed Approach (GPWS Mode 3):** Alerts when loss of altitude is detected immediately after takeoff or initiation of a missed approach.

- 7) **Flight into Terrain when not in Landing Configuration (GPWS Mode 4):** Alerts when descending into terrain without properly configuring the aircraft for landing.
- 8) **Excessive Downward Deviation from an ILS Glideslope (GPWS Mode 5):** Alerts when deviating below glideslope on the ILS final approach segment.
- 9) **500 foot Wake-up Call:** Single audible alert when descending through 500 feet AGL.

8.2. Terrain Display



Figure 8-1: Terrain Display

Display of terrain on the PFI and Map are described in Sections 3 Display Symbology and 5 Menu Functions and Step-By-Step Procedures where applicable.

8.3. Forward Looking Terrain Alert (FLTA) Function



Figure 8-2: FLTA INHBT

FLTA function uses the following to alert to hazardous terrain or obstructions within a search envelope in front of the aircraft:

- | | |
|--------------------------------|----------------------------|
| 1) Terrain database | 6) Aircraft groundspeed |
| 2) Obstruction database | 7) Aircraft bank angle |
| 3) Airport and runway database | 8) Aircraft altitude |
| 4) Aircraft position | 9) Aircraft vertical speed |
| 5) Aircraft track | |

8.3.1. FLTA Modes

FLTA mode is either slaved to the GPS/SBAS navigation mode or set automatically based upon default mode logic.

8.3.2. GPS/SBAS Navigation Mode Slaving

The EFIS performs TSO-C146c GPS/SBAS functions in addition to the TAWS functions. As a result, GPS/SBAS navigation mode is available as an input to the TAWS. The pilot may select an IFR procedure (approach, DP, or STAR), which automatically changes the GPS/SBAS navigation mode to enroute, terminal, departure, or IFR approach as appropriate. In addition, the pilot may select a VFR approach to any runway or user waypoint with a defined approach path. Selection of a VFR approach causes automatic GPS/SBAS navigation mode changes to enroute, terminal, or VFR approach as appropriate.

When slaved, the GPS/SBAS active runway threshold or user waypoint is the reference point for automatic FLTA inhibiting. The advantage is the GPS/SBAS navigation modes are a direct indication to the FLTA function of pilot intent.

8.3.3. Default FLTA Mode

If the default FLTA navigation mode is higher in precedence than the GPS/SBAS navigation mode, FLTA mode is slaved to the default FLTA navigation mode. These modes and order of precedence are:

- 1) **Departure Mode:** Enabled when in ground mode. Reference point for automatic FLTA inhibiting and mode envelope definition is the last point at which the ground definition was satisfied (near the liftoff point). Departure mode ends upon climbing through 1500 feet above or traveling more than 6NM from the reference point.

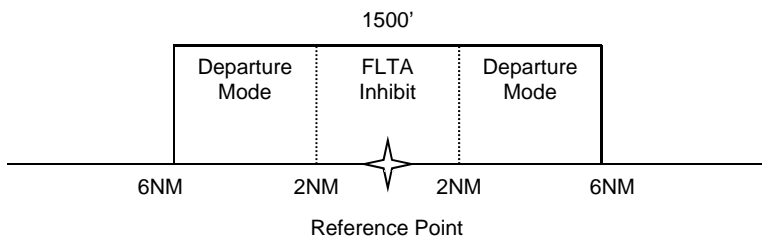

Figure 8-3: Default FLTA INHBT

- 2) **Other Modes:** For other default FLTA modes, reference point for automatic FLTA inhibiting and mode envelope is the nearest runway threshold or user waypoint with a defined approach bearing. TAWS continuously searches all runway thresholds at the nearest three airports to determine the nearest runway threshold. TAWS performs a search for the nearest three airports and nearest user waypoints with a defined approach bearing every 3NM of distance traveled. Modes are as follows:
 - a) **Approach Mode:** When within 1900 feet and 5NM of the reference point.
 - b) **Terminal Mode:** From 5NM to 15NM from the reference point when below an altitude that varies from 1900 feet (at 5NM) to 3500 feet (at 15NM) above the reference point.
 - c) **Enroute Mode:** When not in any other mode.

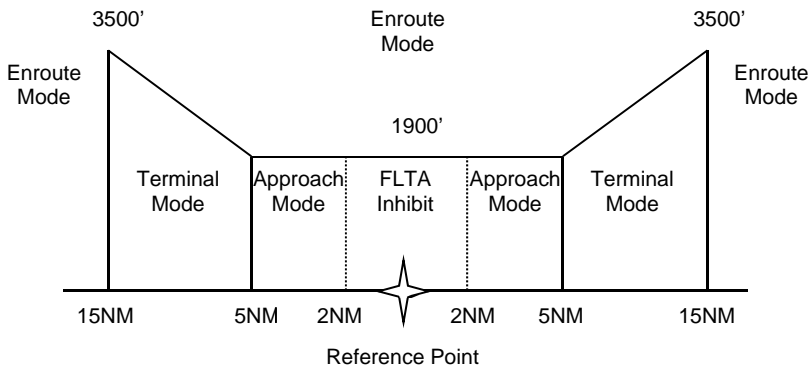

Figure 8-4: FLTA INHBT Mode Areas

8.3.4. FLTA Search Envelope

The FLTA search envelope is an area in front of and below the aircraft. If terrain or obstructions are found within the FLTA search envelope, a caution or warning is given. Dimensions of the search envelope depend upon TAWS type, FLTA mode, and aircraft track, groundspeed, bank angle, and vertical speed. Basic envelope parameters are as follows:

- 1) **TAWS Type:** Determines value of several parameters used to calculate the search envelope.

Table 8-2: FLTA Search Envelope

Envelope	Parameter
Level-Off Rule	Class A & B: 20% of vertical speed Class C: 10% of vertical speed Used for level-off leading for descending flight reduced required terrain clearance (RTC).
Range	60 seconds forward range search envelope. After calculations, GPS/SBAS HFOM is added to range.
Enroute Mode Level or Climbing Flight RTC	Class A & B: 700 feet Class C: 250 feet
Terminal Mode Level or Climbing Flight RTC	Class A & B: 350 feet Class C: 250 feet
Approach Mode Level or Climbing Flight RTC	150 feet

Table 8-2: FLTA Search Envelope

Envelope	Parameter
Departure Mode Level or Climbing Flight RTC	100 feet
Enroute Mode Descending RTC	Class A & B: 500 feet Class C: 200 feet
Terminal Mode Descending RTC	Class A & B: 300 feet Class C: 200 feet
Approach Mode Descending RTC	100 feet
Departure Mode Descending RTC	100 feet

- 2) **Aircraft Track:** Terrain search envelope is aligned with aircraft track.
- 3) **Aircraft Groundspeed:** Used in conjunction with range parameter to determine the look-ahead distance and used with FLTA mode to determine search volume width as follows:
 - a) **Enroute Mode:** Based on a 30° change in track followed by 30 seconds of flight at aircraft groundspeed. Maximum width is 0.5NM either side of track.
 - b) **Terminal Mode:** Based on a 15° change in track followed by 30 seconds of flight at aircraft groundspeed. Maximum width is 0.5NM either side of track.
 - c) **Approach Mode:** Based on a 10° change in track followed by 30 seconds of flight at aircraft groundspeed. Maximum width is 0.3NM either side of track.
 - d) **Departure Mode:** Based on a 10° change in track followed by 30 seconds of flight at aircraft groundspeed. Maximum width is 0.3NM either side of track.

After calculating search volume width as described above, the GPS/SBAS HFOM is added to search volume width.

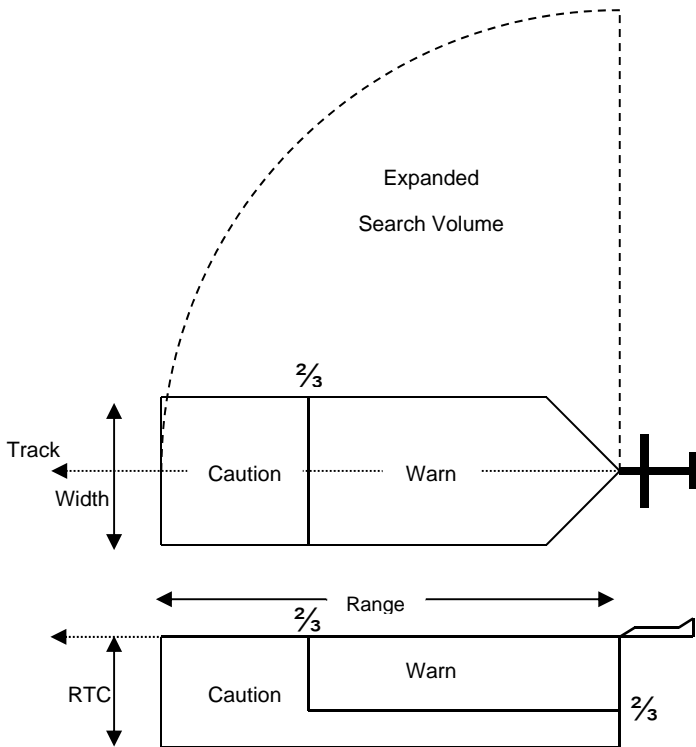

Figure 8-5: FLTA Search Volume

- 4) **Aircraft Bank Angle:** Used to expand the search volume in the direction of a turn and requires at least 10° of bank. In addition, search volume expansion is delayed, so at 10° of bank, the bank angle must be continuously held for 3.25 seconds. The amount of delay is reduced linearly with increased bank angle so at 30° of bank there is no delay time. Delaying is intended to reduce nuisance-search volume expansions when experiencing bank angle excursions due to turbulence.
- 5) **Aircraft Vertical Speed:** Used to determine which RTC values should be used. At vertical speeds above -500 fpm, level and climbing flight RTC values are used. At vertical speeds less than or equal to -500 fpm, descending flight RTC values are used. In addition, vertical speed is used to increase the descending flight RTC value used by the system. The increase in descending flight RTC is based upon a three-second pilot reaction time is used and applied to the level-off rule parameters.

8.3.5. FLTA Alerts and Automatic Popup

When terrain or obstructions fall within the FLTA search envelope, an FLTA warning is generated. Terrain rendering is enabled when an FLTA warning is initiated or upgraded as follows:

- 1) On PFD screen, terrain rendering is enabled;
- 2) On navigation display screen, terrain rendering is enabled only if TAWS Inhibit is not enabled.

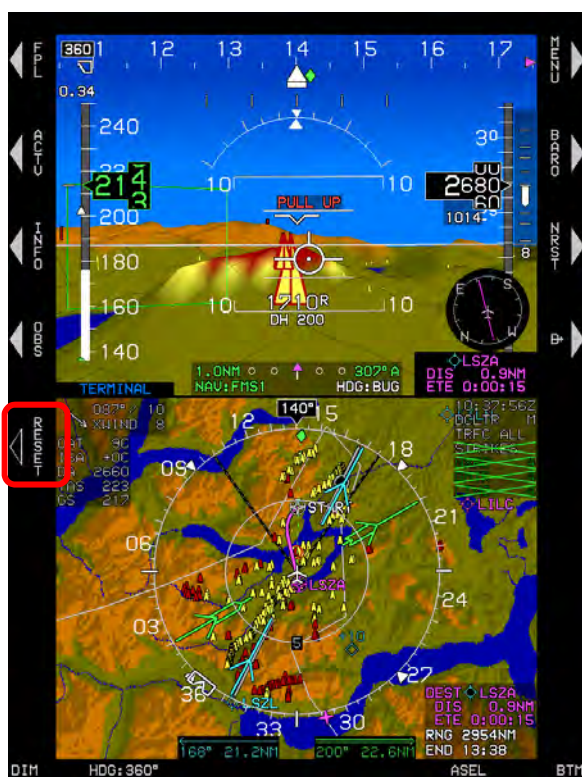

Figure 8-6: Map in Popup Mode

In addition, when an FLTA warning is initiated or upgraded, an automatic popup mode is engaged and bottom area display:

- 1) Switches to navigation display.
- 2) Switches to aircraft centered and heading up.
- 3) Panning disabled.

- 4) Scale set to:
 - a) 10 NM (groundspeed > 200 knots);
 - b) 5 NM (groundspeed \leq 200 knots and groundspeed > 100 knots);
or
 - c) 2 NM (groundspeed \leq 100 knots).

After the popup mode is engaged, the pilot may change any setting automatically changed by the popup mode. In addition, **RESET (L5)** appears for 20 seconds to reset the previous screen configuration with one button press. Popups only occur on IDU #1 with all TAWS classes configured, but do not occur if TAWS inhibit is enabled.

8.4. Premature Descent Alert (PDA) Function

PDA function alerts when descending well below a normal approach glidepath on the final approach segment of an instrument approach procedure. PDA function uses the following:

- 1) GPS/SBAS navigation database
- 2) GPS/SBAS navigation mode
- 3) Aircraft position
- 4) Aircraft altitude

PDA function is armed when on the final approach segment of an IFR approach procedure and below the FAF crossing altitude. The alerting threshold for the PDA function is 0.5° less than the lower of:

- 1) a straight line from the FAF to approach runway threshold; or
- 2) 3°

When the aircraft descends below the threshold, a PDA warning is generated (Figure 8-7).

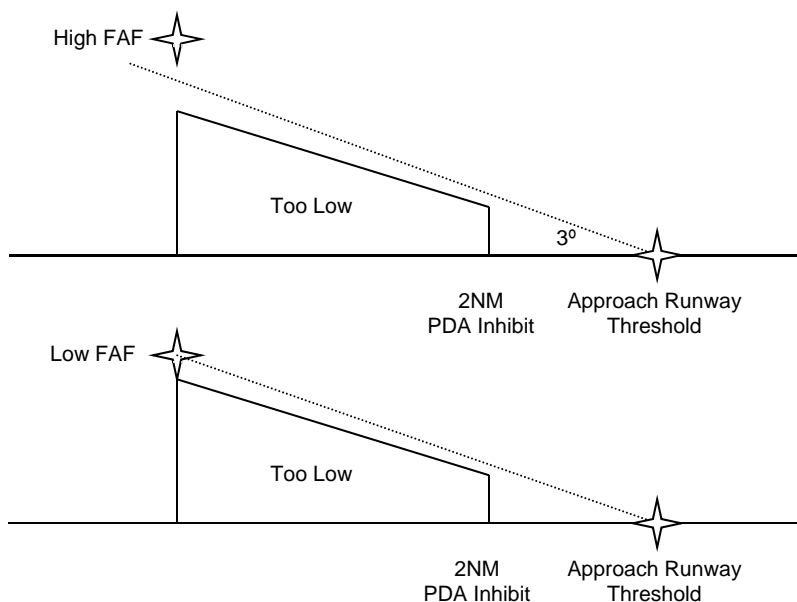
Figure 8-7: PDA Alert Threshold

8.5. Excessive Rate of Descent (GPWS Mode 1)

GPWS Mode 1 function uses aircraft vertical speed information and AGL altitude to alert when high rate of descent above terrain. GPWS Mode 1 has a caution and a warning threshold. When below the thresholds, a GPWS Mode 1 caution or warning is generated.

Table 8-3: GPWS Mode 1 Envelope

Sink Rate (fpm)	AGL Altitude (ft.)	
	Caution Threshold	Warning Threshold
	<div style="background-color: #0070C0; color: white; padding: 2px;">SINK RATE</div> <div style="background-color: #FF8C00; color: white; padding: 2px;">SINK RATE</div>	<div style="background-color: #0070C0; color: white; padding: 2px;">PULL UP</div> <div style="background-color: #FF8C00; color: white; padding: 2px;">PULL UP</div>
< 2360 2360 to 4900	$125\% \times (\text{Sink Rate} - 1416)$ Lesser of: 2450, or, $50\% \times (\text{Sink Rate})$	$66\% \times (\text{Caution Threshold})$

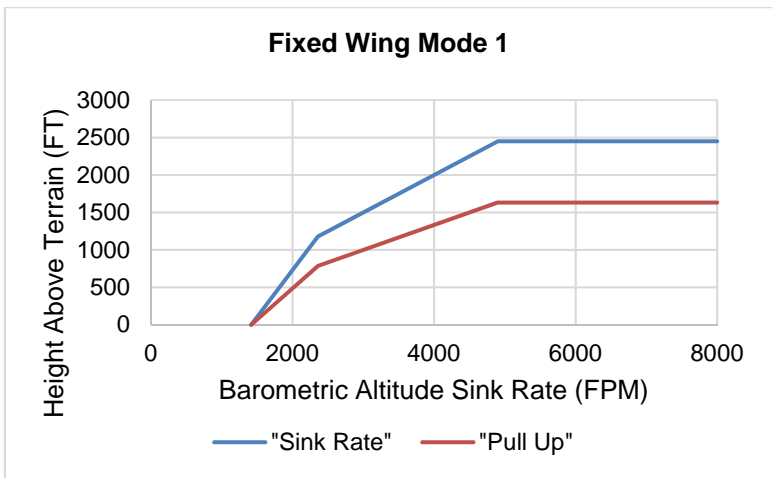

Figure 8-8: Fixed Wing GPWS Mode 1

8.6. Excessive Closure Rate to Terrain (GPWS Mode 2)

GPWS Mode 2 function is present in Class A TAWS and uses filtered AGL rate and AGL altitude to alert when hazardously high rate of change over rising terrain. AGL rate filtering is based upon a 10-second sampling time.

There are two Mode 2 envelopes: Mode 2A which is active when not in landing configuration, and Mode 2B which is active when in landing configuration. Envelope selection is determined as follows.

Table 8-4: GPWS Mode 2 Envelopes

Configuration	Mode 2A	Mode 2B
Retractable gear with defined landing flaps position	Flaps NOT in landing configuration	Flaps in landing configuration
Retractable gear	Landing gear UP	Landing gear DOWN
Fixed gear with defined landing flaps position	Flaps NOT in landing configuration	Flaps in landing configuration
Fixed gear	AGL Altitude > 500 ft or Airspeed > V_{FE}	AGL Altitude \leq 500 ft or Airspeed \leq V_{FE}

When GPWS Mode 2 envelope is pierced, a GPWS Mode 2 caution or warning is generated.

Table 8-5: GPWS Mode 2A Envelopes (NOT in Landing Configuration)

AGL Rate (fpm)	AGL Altitude (ft.)	
	Caution Threshold	Warning Threshold
	TERRAIN TERRAIN	PULL UP PULL UP
< 3900	$80\% \times (\text{AGL Rate} - 2000)$	
> 3900	1520 + 15% of the lesser of:	
	Airspeed (KIAS)	AGL Rate (fpm)
	< 220	6000
	220 to 300	$6000 + 50 \times (\text{Airspeed} - 220)$
	> 300	10,000
	Or AGL Rate	
	$66\% \times (\text{Caution Threshold})$	

Table 8-6: GPWS Mode 2B Envelopes (Landing Configuration)

AGL Altitude (ft.)	
Caution Threshold	Warning Threshold
TERRAIN TERRAIN	PULL UP PULL UP
Lesser of: 800 or $80\% \times (\text{AGL Rate} - 2000)$	$66\% \times (\text{Caution Threshold})$

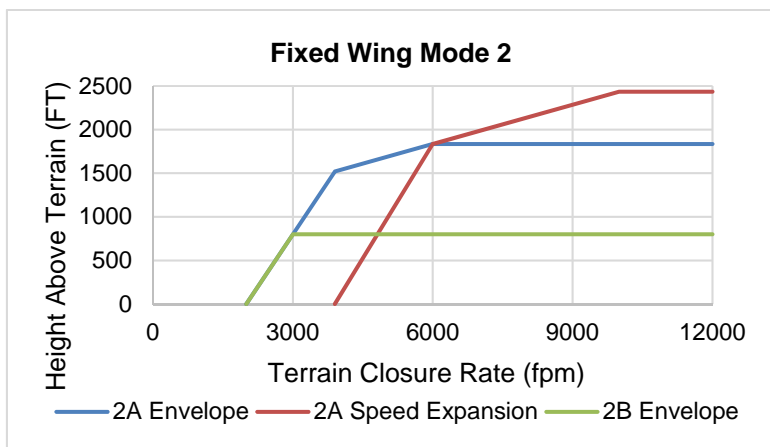
Figure 8-9: Fixed Wing GPWS Mode 2

8.7. Sink Rate after Takeoff or Missed Approach (GPWS Mode 3)

GPWS Mode 3 function uses aircraft vertical speed information and AGL altitude to alert when sink rate is detected immediately after takeoff or initiation of a missed approach. GPWS Mode 3 is armed by either being in ground mode or on the first leg of a missed approach procedure (as determined by the GPS/SBAS) with distance to the active runway threshold increasing. GPWS Mode 3 is disarmed upon climbing through **700 feet AGL** traveling more than **6 NM** from the last point at which the ground definition was satisfied (this is near the liftoff point), or transitioning to the second leg of a missed approach procedure. GPWS Mode 3 has a caution threshold based upon height above terrain and vertical speed. When below the caution threshold (AGL threshold = $1.4 \times$ sink rate), a GPWS Mode 3 caution is generated.

TOO LOW **TOO LOW**

Figure 8-10: GPWS Mode 3 Warning (Sink Rate after Takeoff or Missed Approach)

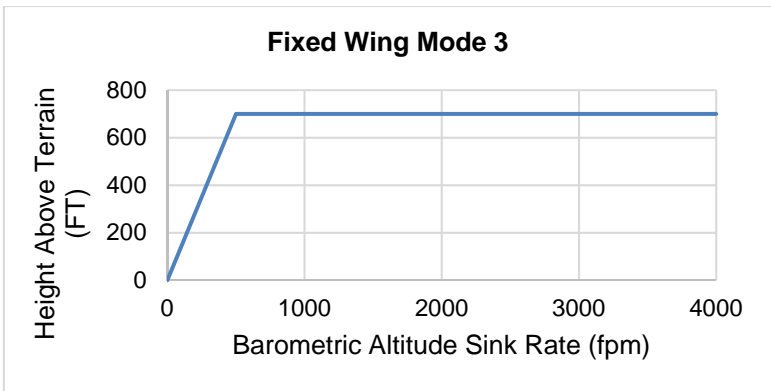

Figure 8-11: Fixed Wing GPWS Mode 3

8.8. Flight into Terrain when not in Landing Configuration (GPWS Mode 4)

GPWS Mode 4 function is present in Class A TAWS and uses aircraft speed information and AGL altitude to alert when descending into terrain without properly configuring the aircraft for landing. There are two Mode 4 envelopes: Mode 4A which gives cautions when landing gear is in other than landing configuration, and Mode 4B which gives cautions when landing gear or flaps are in other than landing configuration. Applicability of Mode 4 envelopes to aircraft types are as follows.

Table 8-7: Mode 4 Envelopes

Configuration	Mode 4A	Mode 4B
Retractable gear with defined landing flaps position	Landing gear up	Landing gear up or flaps not in landing configuration
Retractable gear		Landing gear up
Fixed gear with defined landing flaps position	Not Applicable	Flaps not in landing configuration
Fixed gear		Not Applicable

Mode 4 alerting criteria requires the Mode 4 envelope be entered from above, so changing aircraft configuration while within a Mode 4 envelope does not generate an alert. Mode 4 envelopes consists of low-speed and high-speed regions.

Table 8-8: GPWS Mode 4 Alerting Criteria



Mode	Region	Caution Flag	Single Audible Alert
4A	Low-Speed	 	"Too Low Gear"
	High-Speed		"Too Low Terrain"
4B	Low-Speed		Landing gear up: "Too Low Gear"
	High-Speed		Landing gear down: "Too Low Flaps" "Too Low Terrain"

Table 8-9: GPWS Mode 4 Parameters

Mode	Region	Speed (KIAS)	AGL Altitude (ft.)
4A	Low-Speed	< 182.5	500
	High-Speed	≥ 182.5	Lesser of: 800 or $8 \times (\text{KIAS} - 120)$
4B	Low-Speed	< 138.75	150
	High-Speed	≥ 138.75	Lesser of: 800 or $8 \times (\text{KIAS} - 120)$

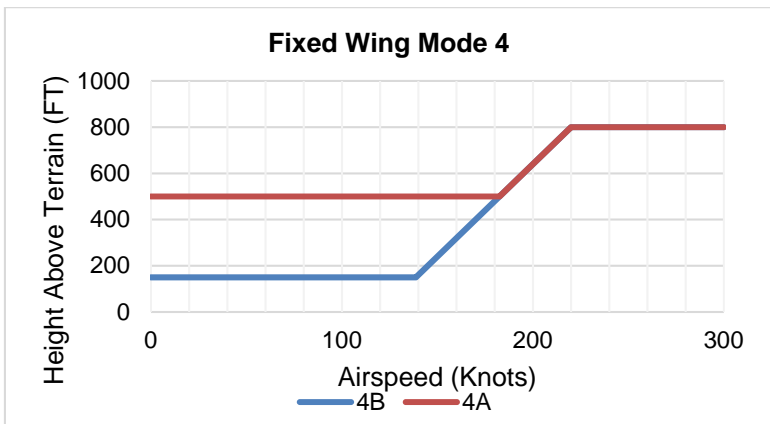

Figure 8-12: Fixed Wing GPWS Mode 4

8.9. Excessive Downward Deviation from an ILS Glideslope (GPWS Mode 5)

GPWS Mode 5 function uses ILS glideslope deviation information and AGL altitude to alert when excessive downward glideslope deviation is detected on the final approach segment of an ILS approach. GPWS Mode 5 is armed when a valid glideslope signal is being received, AND the aircraft is below 1000' AGL.

GPWS Mode 5 has a caution and a warning threshold. When below a threshold, a GPWS Mode 5 warning is generated. The curve compares glideslope deviation to AGL altitude.

Caution Threshold	Warning Threshold
Greater of: $\left[1.3 + 1.4\% \times (150 - \text{AGL Altitude}) \right] \text{ Dots}$ or 1.3 Dots	Greater of: $\left[2 + 1\% \times (150 - \text{AGL Altitude}) \right] \text{ Dots}$ or 2 Dots
GLIDESLOPE	GLIDESLOPE
GLIDESLOPE	GLIDESLOPE

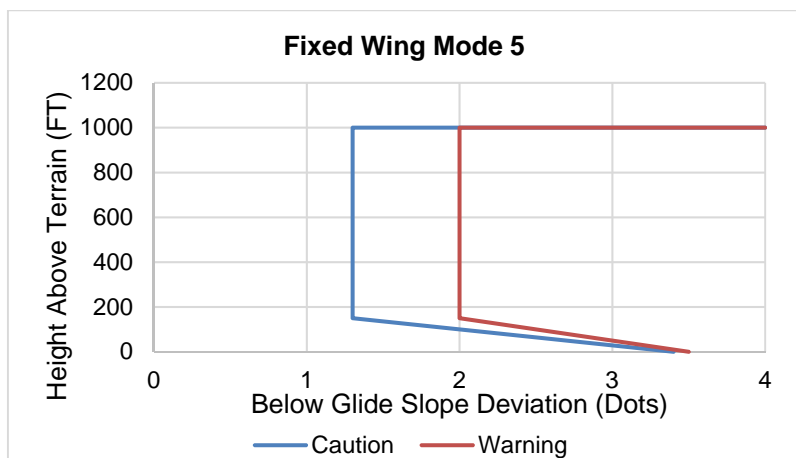

Figure 8-13: Fixed Wing GPWS Mode 5

8.10. 500-Foot Wake-Up Call

This function is present in all TAWS classes. The **500-foot** function includes an arming deadband of **500 feet** to prevent nuisance warnings during low altitude operations. Thus, the aircraft must climb above **1000 feet** AGL to arm the **500-foot** function and generate a **500-foot** annunciation.

8.11. External Sensors and Switches

TAWS requires a variety of inputs from external sensors and switches to perform its functions as follows:

- 1) **GPS/SBAS Receiver.** Source of aircraft position, geodetic height, horizontal figure of merit (HFOM), vertical figure of merit (VFOM), loss of integrity (LOI), and loss of navigation (LON). Connects directly to the EFIS IDU.
- 2) **Air Data Computer (ADC).** Source of barometric altitude, outside air temperature, and vertical speed. Connects directly to the IDU.
- 3) **ILS Receiver.** Glideslope receiver is the source of glideslope deviation.
- 4) **Radar Altimeter (RA).** Source for radar altitude.
- 5) **Gear Position Sensors.** As configured in the system limits, landing gear position discretes are the source.
- 6) **Flap Position Sensor.** As configured in the system limits, flap position discrete is the source.

- 7) **TAWS Inhibit Switch.** As configured in the system limits, used for manual inhibiting of TAWS alerting functions. Gives an indication of actuation (e.g., toggle/rocker or pushbutton with indicator light and **TAWS INHBT** in lower left corner of PFI area of PFD).
- 8) **Audio Mute Switch.** Momentarily activated to silence active audible alerts. It is connected directly to the IDU.
- 9) **Glideslope Deactivate Switch.** As configured in the system limits, momentarily activated to inhibit GPWS Mode 5 function.

Table 8-11: TAWS External Sensors and Switches

TAWS Class Configuration	A				B or C
	RG+F	RG	FG+F	FG	
GPS/SBAS	✓	✓	✓	✓	✓
ADC	✓	✓	✓	✓	✓
Gear Position Sensor	✓	✓			
TAWS Inhibit Switch	✓	✓	✓	✓	✓
Audio Cancel Switch	✓	✓	✓	✓	✓
ILS	✓	✓	✓	✓	
Radar Altimeter	✓	✓	✓	✓	
Flap Position Sensor	✓	✓	✓	✓	
Glideslope Deactivate Switch	✓	✓	✓	✓	

8.12. TAWS Basic Parameter Determination

Fundamental parameters used for TAWS functions are as follows.

Table 8-12: Airplane TAWS Basic Parameters Determination

Parameter	Source	Notes
Aircraft position, groundspeed, and track	GPS/SBAS	HFOM must be less than or equal to the greater of 0.3 NM or the horizontal alert limit (HAL) for the mode of flight.
MSL Altitude	GPS/SBAS	Geodetic height converted to MSL with the current EGM database. To be considered valid for use as MSL altitude, VFOM must be less than or equal to 106 feet. Secondary source of MSL altitude is barometric altitude from an air data computer. Barometric altitude is based upon a barometric setting in the following order of preference:

Table 8-12: Airplane TAWS Basic Parameters Determination

Parameter	Source	Notes
		<p>1) If either the pilot or co-pilot side is operating in QNH mode, the QNH barometric setting is used (on-side barometric setting preferred); or</p> <p>2) If GPS/SBAS geodetic height has been valid within the last 30 minutes, a barometric setting derived from the GPS/SBAS geodetic height is used.</p> <p>If neither of the above conditions are met, MSL altitude is marked as invalid.</p> <p>When a reporting station elevation is determined and outside air temperature is valid, a temperature correction is applied.</p> <p>TAWS uses the lower of the barometric altitude or the temperature-corrected altitude. In the case of QNH-mode barometric setting, reporting station elevation is derived from waypoint or active runway elevations in the active flight plan using the following logic:</p> <p>1) If the aircraft is in TERMINAL, DEPARTURE, IFR APPROACH, or VFR APPROACH mode and an active runway exists, reporting station elevation is the elevation of the active runway threshold.</p> <p>2) Otherwise, if the aircraft is in TERMINAL mode, reporting station elevation is the elevation of the airport causing TERMINAL mode.</p> <p>3) In ENROUTE mode, no reporting station elevation is determined.</p> <p>In the case of GPS/SBAS geodetic height-based barometric setting, reporting station elevation is the GPS MSL altitude reported at the time the</p>

Table 8-12: Airplane TAWS Basic Parameters Determination

Parameter	Source	Notes
		barometric setting was determined (see Section 3 Display Symbology).
Terrain Data	Terrain Database	To be considered valid, the following must apply: <ol style="list-style-type: none"> 1) Aircraft position is valid; 2) Aircraft position is within the boundaries of the terrain database; and 3) Terrain database is not corrupt as determined by built-in test at system initialization and during runtime.
Obstacle Data	Obstacle Database	To be considered valid, the following must apply: <ol style="list-style-type: none"> 1) Aircraft position is valid; 2) Aircraft position is within the boundaries of the obstacle database; and 3) Obstacle database is not corrupt as determined by built-in test at system initialization.
AGL Altitude	Radar Altitude	Secondary source is MSL altitude less terrain altitude.
Vertical Speed	Instantaneous vertical speed	IVSI values come from barometric vertical speed from an ADC "quicken" with vertical acceleration from an AHRS. Secondary source for vertical speed is barometric vertical speed from an ADC. The tertiary source for vertical speed is GPS/SBAS vertical speed providing the VFOM is less than or equal to 106 feet.
Terrain Closure Rate	Smoothed first derivative of AGL altitude	Due to multiple sources for altitude, there are multiple sources for terrain closure rate.
Runway/ Reference point location	EFIS navigation database	To be considered valid, the following must apply: <ol style="list-style-type: none"> 1) Aircraft position is valid;

Table 8-12: Airplane TAWS Basic Parameters Determination

Parameter	Source	Notes
		2) Aircraft position is within the boundaries of the navigation database; and 3) Navigation database is not determined corrupt by built-in test at system initialization.

8.13. TAWS Automatic Inhibit Functions (Normal Operation)

The following automatic inhibit functions occur during normal TAWS operation to prevent nuisance warnings:

- 1) FLTA function is automatically inhibited when in terminal, departure, IFR approach, or VFR approach modes and within 2NM and 1900' of the reference point.
- 2) PDA function is automatically inhibited when within 2NM and 1900' of the approach runway threshold.
- 3) GPWS Modes 1 through 4 are automatically inhibited when below 50 feet AGL (radar altimeter AGL altitude) or below 100 feet AGL (terrain database AGL altitude).
- 4) GPWS Mode 5 is inhibited below 200' AGL. This form of automatic inhibit remains active until the aircraft climbs above 1000' AGL and prevents nuisance alarms on missed approach when the glideslope receiver detects glideslope sidelobes.

8.13.1. TAWS Automatic Inhibit Functions (Abnormal Operation)

The following automatic inhibit functions occur during the specified abnormal operations. System sensor failures, non-installation of optional sensors, database failures, and combinations thereof affect TAWS as follows.

Table 8-13: TAWS Automatic Inhibit Functions

Sensor	Parameters Lost	Terrain Displaced	FLTA	PDA	GPWS Mode					500' Wake-Up
					1	2	3	4	5	
GPS/SBAS (H)	AC Position	Inhibit	Inhibit	Inhibit						
TD	Terrain Elev.	Inhibit	Inhibit							
ILS	Glideslope Dev.								Inhibit	
MSL	MSL Altitude	Inhibit	Inhibit	Inhibit						
GPS/SBAS (H) + RADLT	AC Position, AGL	Inhibit	Inhibit	Inhibit	Inhibit	Inhibit	Inhibit	Inhibit	Inhibit	Inhibit
GPS/SBAS (V) + ADC	MSL Altitude, VSI	Inhibit	Inhibit	Inhibit	Inhibit		Inhibit			
TD + RADLT	Terrain Elev. AGL	Inhibit	Inhibit		Inhibit	Inhibit	Inhibit	Inhibit	Inhibit	Inhibit

Table 8-13: TAWS Automatic Inhibit Functions

Sensor	Parameters Lost	Terrain Displaced	FLTA	PDA	GPWS Mode					500' Wake-Up
					1	2	3	4	5	
MSL + RADLT	MSL Altitude, AGL	Inhibit	Inhibit	Inhibit	Inhibit	Inhibit	Inhibit	Inhibit	Inhibit	Inhibit
GPS/SBAS (V) + ADC + RADLT	MSL Altitude, VSI, AGL ALT	Inhibit	Inhibit	Inhibit	Inhibit	Inhibit	Inhibit	Inhibit	Inhibit	Inhibit

Notes:

- 1) Combinations listed give the minimum combinations with the worst consequences. Many other combinations are possible, but their effects are subsumed within the combinations listed.
- 2) GPS/SBAS (H) = HFOM > max (0.3NM, HAL). Indication is loss of terrain display on PFD and ND.
- 3) GPS/SBAS (V) = VFOM > 106'.
- 4) GPS/SBAS = GPS/SBAS (H) + GPS/SBAS (V). Indication is loss of terrain display on PFD and ND.
- 5) TD = Terrain Data invalid. This is due to being beyond the database boundaries or database corruption.
- 6) ADC = Air Data Computer. Indication is **ADC1 FAIL**, **ADC2 FAIL**, **ADC1/2 FAIL** flag, or red Xs indicating a single ADC failure.
- 7) RADALT = Radar Altimeter. Indication is lack of **RALT FAIL**, **RALT1 FAIL**, **RALT2 FAIL**, **RALT1/2 FAIL** radar altimeter source indication on radar altimeter display.
- 8) ILS = ILS glideslope deviation. Indication is lack of glideslope needles.

- 9) MSL = MSL altitude invalid. Indication is **PLT1 TAWS** or **PLT2 TAWS** or **CPLT1 TAWS** or **CPLT2 TAWS** in the absence of other failures.

8.13.2. TAWS Manual Inhibit Functions

The pilot may select the following manual inhibit functions:

- 1) Terrain display function may be inhibited using EFIS soft menu declutter control.
- 2) All TAWS alerting functions (including popup functionality) are inhibited with the external TAWS inhibit switch, which does not affect the terrain display function, including FLTA warning (red) and caution (amber [yellow]) flags on the map.
- 3) GPWS Mode 5 is inhibited with the glideslope cancel switch when below 1000' AGL. GPWS Mode 5 manual inhibit automatically resets by ascending above 1000'AGL.

8.14. TAWS Selections on PFD

Terrain and obstruction symbology for FLTA alerts meet the following requirements:

- 1) Terrain cells that pierce the FLTA warning volume are colored red.
- 2) Terrain cells that pierce the FLTA caution volume are colored yellow.
- 3) Obstructions whose tops pierce the FLTA warning volume are visually distinct from the non-alerting obstructions and flash.
- 4) Obstructions whose tops pierce the FLTA caution volume are visually distinct from non-alerting obstructions.



Figure 8-14: PFD SVS TAWS Option and Obstructions

PFD Declutter menu includes three option possibilities for TAWS:

- 1) SVS TAWS
- 2) SVS BASIC
- 3) None

The following figures show all possible scenarios including “None” where the aircraft pierces the TAWS FLTA terrain envelope, and SVS TAWS is enabled for the safest possible warning alert condition.

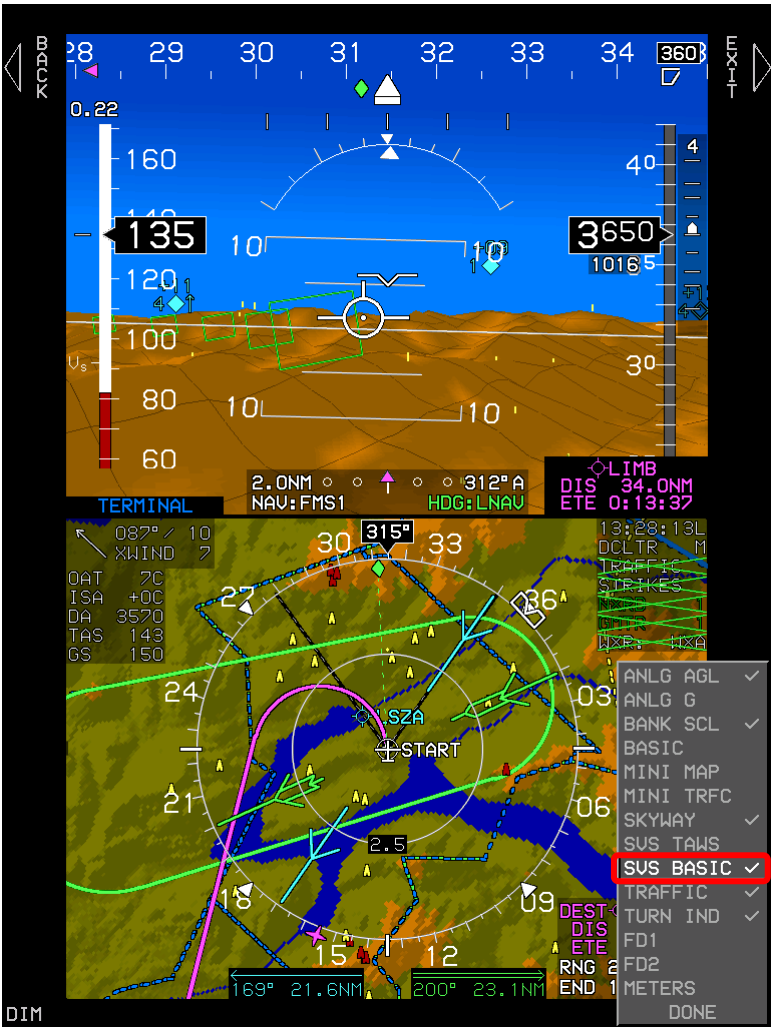

Figure 8-15: PFD SVS BASIC Option



Figure 8-16: PFD SVS TAWS Option

If SVS TAWS and SVS BASIC are not checked and the aircraft pierces the TAWS FLTA terrain envelope, the EFIS automatically enables SVS TAWS.

TERRAIN TERRAIN takes precedence over **OBSTRUCTION OBSTRUCTION**.

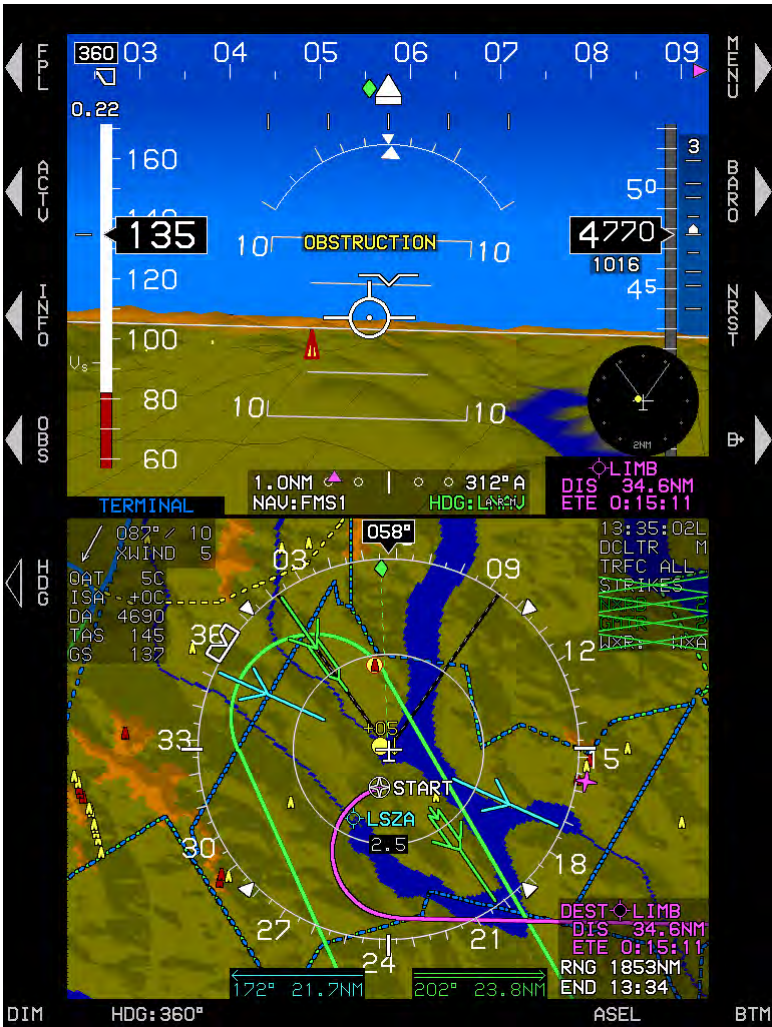

Obstruction within TAWS FLTA caution envelope with audible alert, “Caution Obstruction, Caution Obstruction.” Obstruction symbols flash.

Figure 8-17: PFD Obstruction Caution



Obstruction within TAWS FLTA warning envelope with audible alert, "Warning Obstruction, Warning Obstruction." Obstruction symbols flash.

Figure 8-18: PFD Obstruction Warning

Section 9 Appendix

9.1. Appendix

This section contains a variety of useful information not found elsewhere in the document and includes operating tips, system specifications, and environmental requirements.

9.2. Operating Tips

With the Genesys Aerosystems EFIS installed and certified in all categories of certified aircraft, numerous tips and suggestions are available for obtaining the maximum performance and benefit from this system. Additional operating tips are available with future releases of this publication.

9.3. Domestic or International Flight Planning

Due to the differences in every aircraft avionics suite installation, the pilot should determine what equipment code is applicable for domestic or international flight plans. The aircraft operator must determine which certifications pertain to them. Visit the FAA website, www.faa.gov, for flight plan guidance for both domestic and international filers, as well as, information and documentation regarding FAA, ICAO, and Flight Services agreements and procedures.

9.4. Descent Planning

Instead of performing conventional time/speed/distance/descent-rate calculations, use the waypoint symbol for descent planning. Simply maintain the cruise altitude until the "X" at the bottom of the waypoint symbol is 2-3 degrees below the horizon (as indicated by the pitch scale) then begin a 2-3 degree descent. Maintain the correct descent angle by keeping the flight path marker positioned on the waypoint "X" symbol. Following the skyway boxes assures the VNAV descent angle is maintained.

9.5. Terrain Clearance

Use the flight path marker to evaluate climb performance for terrain clearance. If climbing at the best climb speed to clear terrain and the flight path marker is overlaying the terrain, the climb rate is insufficient. Either the course or climb rate must be altered to adequately clear the terrain. If the flight path marker is well clear of the terrain (overlaying blue sky), the climb is sufficient for the present time, and no further action is necessary until level off.

9.6. Departure Airport Information

On startup, all information for the departure airport is readily available. The altimeter is automatically set to the nearest IFR runway touchdown zone elevation (if Baro Autosetting on Startup is enabled in EFIS limits). Press **NRST (R3)** to reveal the nearest airports where all important data such as elevation, frequencies, and runway lengths are displayed.

9.7. Unique Names for Flight Plans

Multiple routes between the same airport pairs are numbered automatically (KCEW-KDHN) [0], (KCEW-KDHN) [1], etc.). The work-around is to apply this easily remembered differentiation. If a route is flown routinely from one airport to another but different routing is necessary due to weather, hot MOA areas, etc., up to 10 different flight plans may be created for the same departure point and arrival point with different routings.

As an example for departing Sikes on a northern routing (KCEWN) or a southern routing (KCEWS), create two different user waypoints at the departure airport named KCEWN and KCEWS followed by different routing to clear whatever creates the necessity for specific routing, e.g. a MOA.

9.8. Altimeter Settings

Use caution when setting the altimeter and inadvertently changing the transition level. If this is reset to a lower than normal altitude, **CHK BARO** may appear due to the altimeter setting not on 29.92 inHg or 1013 mbar.

9.9. Warnings, Cautions, and Advisories

Review Section 2 System Overview for the conditions precisely defining scenarios for various time-critical warning alerts, warning alerts, master visual and audio alerts, time-critical caution alerts and advisory alerts, as they appear including the conditions and time delay when applicable.

9.10. Magnetic vs. True North Modes of Operation

There are two modes for the AHRS:

- 1) Slaved mode (i.e., compass rose stabilized by Earth's magnetic flux horizontal field) is the normal mode. It works well over most of the surface of the earth (i.e., areas with a horizontal field of 5000nT or above, which includes about 2/3^{rds} of Canadian NDA). ADAHRS senses magnetic flux with a 3D magnetometer. Performance in small horizontal fields is installation dependent as variable magnetic disturbances from the aircraft may begin to predominate.

- 2) Free or “DG” mode (i.e., compass rose not stabilized by the Earth’s magnetic flux horizontal field and subject to drift) is used in areas of magnetic disturbances (oilrigs, MRI machines, etc.) or in areas where the horizontal field is too weak. In Free/“DG” mode, heading no longer corrects towards Earth’s magnetic flux horizontal field, and the pilot may “slew” the heading solution.

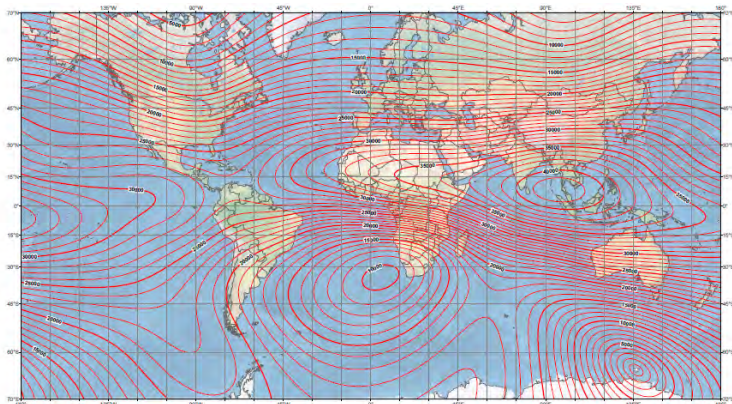

Figure 9-1: US/UK World Magnetic Model

There are two modes for the EFIS:

- 1) Magnetic North mode: Heading from AHRS (whether slaved or Free/“DG”) is used as-is and is expected to reflect magnetic north. GPS track is converted from true north-referenced to magnetic north-referenced with a magnetic variation database. PFD scenes and compass rose symbols are aligned with magnetic north. Wind is displayed referenced to magnetic north.
- 2) True North mode: GPS track is used as-is and reflects true north. When AHRS is in slaved mode, heading from AHRS is converted from magnetic north-referenced to true north-referenced using a magnetic variation database. When AHRS is in Free/“DG” mode, heading from the AHRS is used as-is and is expected to reflect true north. PFD scenes and compass rose symbols are aligned with true north. Wind is displayed referenced to true north.

NOTE:

Designating magnetic north vs. true north mode is critical since it determines how the inputs are used, i.e., the relationship between GPS track and ADAHRS heading. Mixing things up in Free/"DG" mode (i.e., slewing the compass rose to match magnetic north when in true north mode and vice-versa) may result in large errors in wind calculations and GPS track/flight path marker displays.

9.11. Altitude Miscompare Threshold

The altitude miscompare threshold is based upon allowable altitude error. There are two components to allowable altitude error, instrument error and installed system error. Allowable instrument error is based upon the values of SAE AS8002A Table 1 as follows.

Table 9-1: Allowable Instrument Error	
Altitude	Allowed Error
Sea Level	25'
1,000'	25'
2,000'	25'
3,000'	25'
4,000'	25'
5,000'	25'
8,000'	30'
11,000'	35'
14,000'	40'
17,000'	45'
20,000'	50'
30,000'	75'
40,000'	100'
50,000'	125'

Allowable installed system error is added on top of instrument error and these values are derived from the regulations as follows.

Table 9-2: Regulatory Reference	
Regulation	Allowed Error
14 CFR § 23.1325	At sea level, the greater of 30' or 30% of the calibrated airspeed in knots. This increases proportionally to SAE AS8002A Table 1 at higher altitudes.
14 CFR § 25.1325	

An allowable altitude error is computed for each compared value and added together to create the altitude miscompare threshold. This accommodates for the values deviating in different directions.

Worked example for a calibrated airspeed of 100 knots and comparing a first altitude of 3,490' with a second altitude of 3,510':

- 1) Calculate allowable instrument error based upon altitudes:
 Allowable Instrument Error #1 = 50'
 Allowable Instrument Error #2 = 50'
- 2) Calculate allowable installed system error based upon altitudes and calibrated airspeed:
 Allowable Installed System Error #1 = 30'
 Allowable Installed System Error #2 = 30'
- 3) Calculate altitude miscompare threshold based upon sum of above allowable errors:
 Altitude Miscompare Threshold = 160'

9.12. Airspeed Miscompare Threshold

Airspeed miscompare threshold is based upon allowable airspeed error. There are two components to allowable airspeed error, instrument error and installed system error. Allowable instrument error is based upon the values of SAE AS8002A Table 3 as follows.

Calibrated Airspeed	Allowed Error
50 knots	5 knots
80 knots	3 knots
100 knots	2 knots
120 knots	2 knots
150 knots	2 knots
200 knots	2 knots
250 knots	2.4 knots
300 knots	2.8 knots
350 knots	3.2 knots
400 knots	3.6 knots
450 knots	4 knots

Allowable installed system error is added on top of instrument. Error and these values are derived from the regulations as follows.

Table 9-4: Airspeed Regulatory Reference

Regulation	Allowed Error
14 CFR § 23.1323	Starting from $(1.3 \times V_{S1})$: Greater of 5 knots or 3%. Do not perform a comparison if either value is below $(1.3 \times V_{S1})$.
14 CFR § 25.1323	Starting from $(1.23 \times V_{SR1})$: Greater of 5 knots or 3%. Do not perform a comparison if either value is below $(1.23 \times V_{SR1})$. System uses V_{S1} as a substitute for V_{SR1} .

An allowable airspeed error is computed for each compared value and added together to create the airspeed miscompare threshold and accommodates for the values deviating in different directions.

9.13. Jeppesen Sanderson NavData® Chart Compatibility

As GPS navigation, flight management systems, computer flight maps, and computer flight planning systems have gained acceptance, avionics companies and software developers have added more features. Even with the many systems available today, paper enroute, departure, arrival, and approach charts are still required and necessary for flight. Avionics systems, flight planning, computer mapping systems, and associated databases *do not* provide all of the navigation information needed to conduct a legal and safe flight. They are not a substitute for current aeronautical charts.

See www.Jeppesen.com for the latest information on coding instrument procedures, naming conventions, altitudes within the database, and aeronautical information compatibility.

9.14. ARINC 424 Path-Terminator Leg Types

For information, definitions, and examples, visit the FAA website, www.faa.gov, to view the Instrument Procedures Handbook (FAA-H-8083-16A).

9.15. Data Logging and Retrieval

The EFIS logs all data associated with a flight, including all flight instrument and navigation data, which may be downloaded for review after flight. Data from the last 5 flights or 20 hours are logged at a one-second interval.

Data logging files contain recordings of flight and engine parameters of up to five hours each from the previous five system operations. During system operation, flight and engine parameters are recorded every one second.

Each time the parameters are recorded, a Zulu time stamp followed by three lines of comma delimited ASCII text data are written where the first line contains flight parameters and, the second line contains engine parameters.

With IDU powered off, open USB door, and insert USB flash drive. Power up and select **Download Log Files** to create a “log” directory on the USB flash drive and copy the data logging files into the directory.

CAUTION:

Always install a valid USB flash drive in the IDU prior to activating any GMF to avoid erroneous failure indications or corruption of the IDU.

9.15.1. Delete Log Files

- 1) If there are problems updating a navigation database or application software due to an excessively large log file, select **Delete Log Files** to delete all log files in the log directory.

Files named “LOG00.dat” thru “LOG04.DAT” and “MSGLOG.DAT” are deleted. This does not affect operations of the EFIS, as the EFIS generates new “LOG00.DAT” and “MSGLOG.DAT” files once a flight (power cycle) has started.

- 2) Press any button on the IDU or push **1**, **2**, or **3** to return to the ground maintenance menu.

9.15.2. Logged Flags and Custom CAS Messages

Flags and custom CAS messages are logged in memory to a file named “caslog00.csv” (*.csv files may be opened in Microsoft Excel or similar spreadsheet software). In addition, data from the previous four flights are saved in files “caslog01.csv” through “caslog04.csv.” Upon system start, the existing “caslog00.csv” through “caslog03.csv” files are renamed “caslog01.csv” through “caslog04.csv,” and “caslog00.csv” is opened for active logging.

The first line of the log files contains column headings related to the flag’s text (for standard warning functions) or the “CAS Log File Text” parameter (for custom CAS messages). All standard warning functions are logged. Only custom CAS messages with valid “CAS Log File Text” parameters (i.e., not an empty string) are logged. Within the data fields of the log file, values are written as in Table 9-5.

Table 9-5: Log File Values	
Category	Value
NORMAL	0
ADVISORY	1
CAUTION	2
WARNING	3

9.16. Routes and Waypoints

9.16.1. VFR Flight Planning

The navigation database includes VFR waypoints, which consist of five digits beginning with “VP.” These may be found on VFR charts and should be loaded in the FMS prior to flight to ensure they are available in the database, and info checked for proper location.

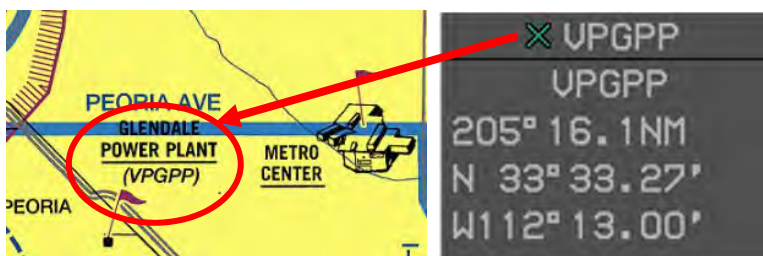

Figure 9-2: VFR Waypoint

9.16.2. Download Routes and User Waypoints

- 1) Select **Download Routes and User Waypoints** from the GMF to download all routes and user waypoints stored in the IDU to the USB flash drive. This option is useful for fleet operations where multiple aircraft fly the same routes.
- 2) Routes are stored on USB flash drive as NAME1-NAME2.RTE where NAME1 is the 1- to 5-character designation of the origin waypoint and NAME2 is the 1 to 5-character designation of the destination waypoint. User waypoints are stored on the USB flash drive as “USER.DAT.”

9.16.3. Upload Routes and User Waypoints



To copy all routes and user waypoints from a USB flash drive to the IDU, select **Upload Routes and User Waypoints** from GMF. Use this option in conjunction with the “Download Routes and User Waypoints” option to upload the same routes and user waypoints in multiple aircraft.

9.16.4. Delete Routes

When corrupted routes cause the IDU to reboot continually, select **Delete Routes** on GMF to remove all routes from the IDU.

9.17. Summary of Asterisk Symbology in Pilot Guide

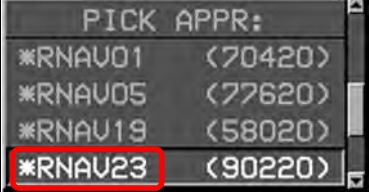
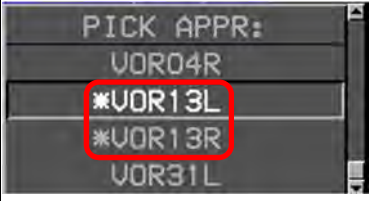
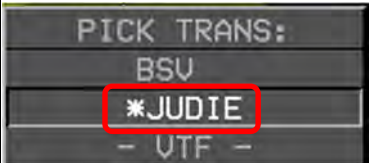
Table 9-6: Summary of Asterisk Symbology Use

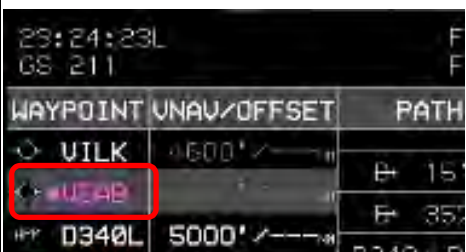
Examples of Asterisk Locations	Meaning of Asterisk Use
 <p>Examples include “VOR or GPS RWY...” or “RNAV (GPS) RWY...”</p> 	<p>Approved approaches are noted by an asterisk (*) before the approach procedure label. These approaches do not require any ground based navigational aids.</p> <p>Instrument approach title includes “RNAV” or “(GPS).”</p>
	<p>Transition most likely selected due to avenue of arrival. (Not all instrument procedures include a transition.)</p>
 	<p>In addition to the magenta color, asterisk designates the active leg.</p>

9.18. Changing Instrument Approach Procedure at Same Airport

Changing complete instrument procedures is the same for a STAR, or DP. Changing the runway assigned is similar as changing the instrument approach procedure.

WAYPOINT	UNAU/OFFSET	PATH	DIST	ETE	ETA	FUEL
17:15:30L GS 214		FUEL 3743LBS FLOW 236PPH				
◆ KCNO	3500' / ---	B+ 256°	12.6nm	0:04	17:22	3717
◆ *KFUL	3500' / ---	B+ 064°	13.5nm	0:03	17:25	3702
◆ SAGER	3500' / ---	○ 196°	24.5nm	0:06	17:32	3675
◆ SAGER	3400' / ---	B+ 196°	4.3nm	0:01	17:34	3670
◆ SNAKE	3400' / ---	B+ 196°	2.4nm	0:00	17:34	3667
◆ HUKEH	2800' / ---	B+ 196°	2.2nm	0:00	17:35	3665
◆ LEMON	2200' / ---	B+ 196°	6.6nm	0:01	17:37	3657
◆ RW20R	93' / ---	196° 460'	1.1nm	0:00	17:37	3656
◆ -ALT-	460' / ---	B+ 196°	10.9nm	0:03	17:40	3644
◆ MINOE	3000' / ---					
◆ (KSNA)						

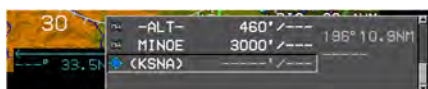

- NAV LOG shows the ILS RWY 20R procedure loaded and currently in the active flight plan.
- ATC advises that the ILS is out of service and to plan on the RNAV (RNP) Z RWY 20R instrument approach at KSNA.
- On any IDU, press **ACTV (L2)**, rotate **1** to **(KSNA)**, and push to enter. (Example on the PFD.)
- Rotate **1** to **IFR APPR..** and push to enter.
- Rotate **1** to ***RNAV20RZ** and push to enter.
- Rotate **1** to desired transition and push to enter.
- Rotate **1** to runway contained within ATC clearance (or choice) and push to enter.
- Push **1** to confirm replacing approach procedure.
- ATC issues clearance to maintain 4,600' and fly direct to DEKRT intersection.
- Rotate **1** to **DEKRT**, press **DP** (**R4**) then push **1** to enter.



- 11) Push **1** to enter for the EFIS to overfly DEKRT as a waypoint.
- 12) Continue to reset minima, QNH, etc., and proceed with new approach procedure.

9.19. Use of NRST ILS Feature as Shortcut to Full ILS Procedure

When a NRST ILS approach has been created, the following actions occur automatically:

- 1) Previous active flight plan is deleted.
- 2) Flight plan to the ILS airport is created.
- 3) A vectors-to-final ILS approach is activated.
- 4) Heading bug is activated to the current heading.
- 5) VLOC 1 and VLOC 2 OBS are set to the associated localizer course.
- 6) ILS frequency is automatically transmitted to NAV#1 in standby position when system enabled.
- 7) EFIS changes to LOC1, and VDI indicates source of glideslope GS1 when signal is received.

Items #5 and #6 remain saved and can be used if a full ILS procedure is to replace the NRST ILS. This can save time by skipping the setting of the VLOC1 and VLOC2 OBS settings and entering the ILS frequency in both Navigation receivers (in the case when auto-tuning is enabled).

The following step-by-step procedure can be used after a NRST ILS RWY 34 at KHPN procedure has been confirmed (as long as the same ILS procedure is desired) in place of the VTF ILS.



- 1) Press **ACTV (L2)**. Rotate **1** to **(KHPN)** and push to enter.

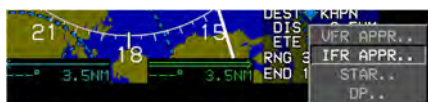

- 2) Rotate **1** to **IFR APPR..** and push to enter.



- 3) Rotate **1** to the same ILS confirmed in the NRST ILS procedure (**ILS34**) and push to enter.



- 4) Rotate **1** to desired transition and push to enter.



- 5) Rotate **1** to desired runway and push to enter.



- 6) Push **1** to confirm the full ILS RWY 34 at KHPN is replacing the VTF ILS 34 at KHPN.
- 7) Continue with managing the active flight plan to comply with ATC clearances with access to all terminal fixes, which were not in view with the NRST ILS VTF procedure.

NOTE:

With changing of the original active flight plan, it is extremely important to verify the OBS settings and ILS frequencies with current NAV data and set/identified correctly in the EFIS and Navigation receivers.

9.20. EFIS NAV Source Management

The default navigation source is FMS when the EFIS initializes and this NAV source can never be decluttered from the system. Most EFIS installations are configured with dual VOR navigation receivers bringing the maximum NAV sources to three total.



Figure 9-3: NAV Source Management

With FMS as the selected NAV source, VOR1 and VOR2 OBS settings can be set for later use and left in the background. Only one NAV source can be indicated at a time in the CDI area. While on NAV source VOR1 or VOR2, the FMS is displayed in the form of HITS guidance and MFD page magenta line.

The selected NAV source is never hidden and always indicated as shown in Table 9-7.

Table 9-7: NAV Source Indications

Nav Source	Indication	Definition
	2.0NM ○ ○ ↑ ○ ○ 204° A NAV: FMS1 HDG: LNAU	FMS (GPS1 or GPS2 source of navigation guidance) enroute mode of navigation.
	2.0NM ○ ○ ↑ ○ ○ 204° A NAV: FMS2 HDG: LNAU	

Table 9-7: NAV Source Indications











Nav Source	Indication	Definition
	 	<p>FMS (GPS1 or GPS2 source of navigation guidance) LP/LPV approach mode of navigation.</p> <p>HSI (GPS1 or GPS2 source of navigation guidance)</p>
	  	<p>VOR1 navigation receiver when tuned to a VOR frequency.</p> <p>VLOC1 navigation receiver tuned to an ILS/localizer frequency.</p> <p>HSI VOR1 source of navigation guidance.</p> <p>HSI VLOC1 source of navigation when tuned to an ILS/localizer frequency.</p>

Table 9-7: NAV Source Indications

Nav Source	Indication	Definition
		VOR2 navigation receiver when tuned to a VOR frequency.
		VLOC2 navigation receiver tuned to ILS/Localizer frequency.
	 	<p>HSI VOR1 source of navigation guidance.</p> <p>HSI VLOC2 source of navigation when tuned to ILS/localizer frequency.</p>

9.21. EFIS Training Tool (ETT)

See the Installation and User Guide distributed with the ETT install files for installation directions and how to use the EFIS Training Tool.

Use the ETT to create routes and user waypoints to save and upload into the aircraft mounted IDUs. When uploading a saved flight plan (route) into an aircraft mounted IDU, the following rules apply:

- 1) Either upload flight plan (route) into each IDU to ensure flight plan (route) is saved in the route directory (all other displays); Or
- 2) Upload flight plan (route) into one display while in the ground mode. When in flight mode, activate that flight plan, and on any other display, view active flight plan and press **SAVE (L1)** to save flight plan in the route directory. This action saves the new uploaded flight plan (route) in all other displays.

NOTE:

In a two-sided system, crossfill must be enabled to save flight plan to all other displays on each side of the system.

The ETT has a bezel with simulated buttons and encoders responsive to mouse and keyboard messages. Bezel graphics are derived from actual bezel design data, and the ETT presents an active display with 1:1 pixel correspondence to an actual IDU display. The audio output capability for the ETT matches the audio functionality in the actual IDU. This training tool simulates the functionalities of the IDU, which begins flight in Reno, Nevada at approximately 8000' MSL. If different ETT startup conditions are required, they may be edited.

Flight plans may be created (on the PFD or MFD), stored, and activated in the same manner as on the EFIS displays installed in the aircraft. This allows for moving the start point to anywhere in the world where loaded NavData® is present for practicing published procedures. As with the demonstrator program, the aircraft begins flying at approximately 8000' MSL in the vicinity of Reno Nevada USA (unless the simulate.ini program is loaded). If an active flight plan is activated, the aircraft begins by intercepting the first leg at a 45° angle.

9.22. USB Flash Drive Memory Limitations

When powering up the IDU with a USB flash drive inserted and “Error: No updater files found on USB drive” displays, the USB flash drive is likely not acceptable for loading or transferring data.

- 1) Ensure the USB flash drive with required files is properly connected.
- 2) Try again after reboot.
- 3) Press any button to continue.
- 4) Try a different USB flash drive.

NOTE:

USB flash drive must be formatted as FAT16 or FAT32.

If the flash drive is not recognized, try another source.

9.23. Certification Basis

The following TSOs are considered applicable to the IDU-680 (depending upon the features of the installed software).

Document Number	Document Title	
ARINC 429-16	Mark 33 Digital Information Transfer System (DITS)	
ARINC 735A-1	Traffic Alert and Collision Avoidance System	
EIA-232D	Interface between Data Terminal Equipment and Data	
EIA-422A	Electrical Characteristics of Balanced Voltage Digital Interface Circuits	
FAA AC 23.1311-1B	Installation of Electronic Display in Part 23 Airplanes	
RTCA/DO-155	Minimum Performance Standards - Airborne Low-Range Radio Altimeters	
RTCA/DO-229D	Minimum Operational Performance Standards for Global Positioning System/Wide Area Augmentation System Airborne Equipment	
RTCA/DO-283A	Minimum Operational Performance Standards for Required Navigation Performance for Area Navigation	
SAE AS396B	Bank and Pitch Instruments (Indicating Stabilized Type)	
SAE AS8002A	Air Data Computer - Minimum Performance Standard	
TSO-C4c	Bank and Pitch Instruments	
TSO-C87	Airborne Low-Range Radio Altimeter	
TSO-C106	Air Data Computer	
TSO-C151b	Terrain Awareness and Warning System	
TSO-C113	Airborne Multipurpose Electronic Displays	SAE AS8034
TSO-C52b	Flight Director Equipment	SAE AS8008
TSO-C146a	Stand-Alone airborne navigation equipment using the Global Positioning System (GPS) Augmented by the Wide Area Augmentation System (WAAS)	
N/A	Airplane Aerodynamics and Performance, Lan and Roskam, 1981.	

9.24. Environmental Requirements

While the IDU-680 meets the following RTCA/DO-160F requirements, Genesys Aerosystems claims the following:

- 1) The coldest storage temperature is -55°C.

- 2) Coldest condition in which the units can be powered up is -40°C. It takes at least four minutes to warm up with the internal heater circuit operating.

Sec.	Condition	Cat.	Test Category Description	Notes
4.0	Temperature and Altitude	F2	Equipment intended for installation in non-pressurized and non-controlled temperature location in an aircraft that is operated at altitudes up to 55,000 ft. (16,800 m) MSL. Operating Low Temp: -55° C Operating High temp: +70° C Ground Survival Low Temp: -55° C Ground Survival High Temp: +85° C Altitude: +55,000 feet	+75°C for Short-Time Operating High Temp. Cat. V (30 minutes) for loss of cooling.
5.0	Temperature Variation	B	Equipment in a non-temperature-controlled or partially temperature controlled internal section of the aircraft.	
6.0	Humidity	B	Equipment intended for installation in civil aircraft, non-civil transport aircraft and other classes, installed under conditions in which a more severe humidity environment than standard conditions may be encountered.	
7.0	Operational Shocks & Crash Safety	B	Equipment generally installed in fixed-wing aircraft or helicopters and tested for standard operational shock and crash safety.	Aircraft Type 5, Test Type R for Crash Safety Sustained Test
8.0	Vibration	H + R + U	H – Demonstrates performance at high-level, short duration transient vibration levels R - (Fixed-Wing) Demonstrates performance at higher, robust vibration levels and after long term vibration exposure.	Cat. H, curve R Cat. R, curves B, B1

Sec.	Condition	Cat.	Test Category Description	Notes
			U - (Helicopter w/Unknown Frequencies) Demonstrates performance at higher vibration levels and after long term vibration exposure for fuselage and instrument panel equipment when the specific rotor frequencies are unknown.	Cat. U, curve G
9.0	Explosive Atmosphere	X	Not Applicable	
10.0	Waterproofness	W	Equipment is installed in locations where it may be subjected to falling water, such as condensation	Drip proof test
11.0	Fluids Susceptibility	X	Not Applicable	
12.0	Sand and Dust	S	Equipment is installed in locations subject to blowing sand and dust.	
13.0	Fungus Resistance	F	Demonstrate whether equipment material is adversely affected by fungi growth.	By Analysis
14.0	Salt Fog	S	Equipment is subjected to a corrosive atmosphere	
15.0	Magnetic Effect	Z	Magnetic deflection distance less than 0.3m.	
16.0	Power Input	Z	Equipment intended for use on aircraft DC electrical systems where the DC supply has a battery whose capacity is small compared with the capacity of the DC generators.	200 ms power interruption capacity
17.0	Voltage Spike	A	Equipment intended primarily for installation where a high degree of protection against damage by voltage spikes is required.	
18.0	Audio Frequency Conducted Susceptibility-Power Inputs	Z	Equipment intended for use on aircraft DC electrical systems where the DC supply may not have a battery of significant capacity floating on the dc bus at all times.	

Sec.	Condition	Cat.	Test Category Description	Notes
19.0	Induced Signal Susceptibility	ZC	Equipment intended primarily for operation in systems where interference-free operation is required on aircraft whose primary power is constant frequency or DC.	
20.0	Radio Frequency Susceptibility (Radiated and Conducted)	Y	Equipment and interconnecting wiring installed in severe electromagnetic environments and to show compliance with the interim HIRF rules.	Radiated: K Minimum level at all frequencies to be 100V/m
21.0	Emission of Radio Frequency Energy	M	Equipment in areas where apertures are EM significant but not in direct view of aircraft antennas, such as passenger cabin or cockpit	
22.0	Lightning Induced Transient Susceptibility	A3J3 3	Equipment interconnected with wiring installed within any airframe or airframe section when structural resistance is also a significant source of induced transients, (i.e., carbon fiber composite structures). Level 3 designates equipment and interconnecting wiring installed in a moderately exposed environment.	Level 4 for MSU and OAT Probe pins.
23.0	Lightning Direct Effects	X	Not Applicable	
24.0	Icing	X	Not Applicable	
25.0	Electrostatic Discharge (ESD)	A	Electronic equipment that is installed, repaired, or operated in an aerospace environment.	
26.0	Fire, Flammability	C	Non-metallic equipment, component parts, sub-assemblies installed in pressurized or non-pressurized zones and non-fire zones with largest dimension greater than 50 mm.	By Analysis

Traffic

T 1. Traffic Page Access



1

PFD Traffic Page Access



2

MFD Traffic Page Access

Figure T-1: Traffic Page Access

T 2. Menu Declutter



PFD DCLTR Traffic



PFD ND Format Traffic

Figure T-2: PFD MENU DCLTR and FORMAT TRAFFIC

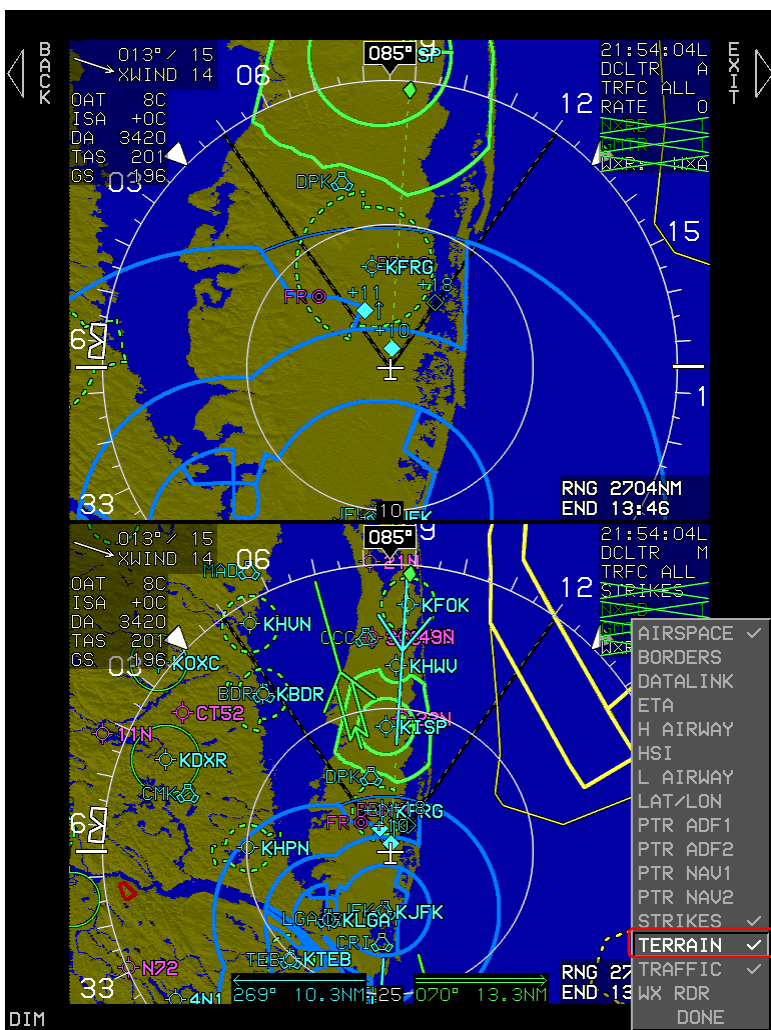

MFD FORMAT DCLTR Traffic for top or bottom areas.
This view showing the bottom area only.

Figure T-3: MFD MENU FORMAT DCLTR TRAFFIC

T 3. Traffic Symbolology



Figure T-4: Traffic Symbolology





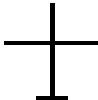

Table T-1: Traffic Symbolology	
Type Traffic	Symbology
TCAS-I, TCAS-II, TAS, and TIS-A	   
	<p>Other Traffic Proximate Advisory Traffic Advisory (Flashing) Resolution Advisory (Flashing)</p>
Ownship Symbol	<p>Airplane w/o M_{MO} Airplane with M_{MO}</p>
	 

Table T-2: ADS-B and TIS-B Traffic Symbols

	Other Traffic	Proximate Advisory	Traffic Advisory (Flashing)
High-Integrity Traffic with Track Information			
High-Integrity Traffic without Track Information			
Degraded Position Traffic with Track Information			
Degraded Position Traffic without Track Information			

T 3.1. Traffic Display Definitions

- 1) Resolution Advisory (**RA**): Traffic with a dangerous closest point of approach and generates climb or descent commands as defined by internal TCAS-II sensor logic.

When TCAS-II is enabled, the VSI background functions as an RA display with green and red colored regions for RA guidance.

Figure T-5: TCAS-II RA Indication

- 2) Traffic Advisory (**TA**): Traffic with a dangerous closest point of approach as defined by internal traffic sensor logic.
- 3) Proximate Advisory (**PA**): Traffic within 6 NM and ± 1200 feet from ownship that is not a RA or TA.

- 4) Other Traffic (OT): Traffic beyond 6 NM or ± 1200 feet from ownship that is not a RA or TA.

T 3.2. Traffic Rendering Rules

Type Traffic	Distance	Results
TA and RA Traffic	Off-scale	Displayed with half-symbols
	No bearing	Displayed with text
OT and PA Traffic	Beyond 6 NM	Not displayed
	Off-scale or no bearing	
TCAS-I, TCAS-II, TAS, or TIS-A Sensor	Within 200' of ground	ADS-B and TIS-B ground traffic displayed

Mode	Parameter
AUTO	If aircraft VSI is less than -500 fpm, traffic within +2,700 and -9,900 feet of aircraft altitude displayed. If aircraft VSI is more than +500 fpm, traffic within -2,700 and +9,900 feet of aircraft altitude displayed. Otherwise, traffic within -2,700 and +2,700 feet of aircraft altitude displayed.
ABOVE	Traffic within -2,700 and +9,900 feet of aircraft altitude displayed.
BELOW	Traffic within +2,700 and -9,900 feet of aircraft altitude displayed.
NORMAL	Traffic within -2,700 and +2,700 feet of aircraft altitude displayed.
ALL	All received traffic displayed, no altitude filtering.

Traffic popups: When a traffic alert is generated, a popup function displays traffic on the PFI, moving map page, and traffic thumbnail on the PFI.

T 3.3. Traffic Thumbnail

When selected from declutter options, the traffic thumbnail is displayed in the lower right corner of the PFI area of the PFD above the active waypoint identifier and has clock face markings fixed at the 6 NM scale.



The traffic thumbnail is automatically enabled while there is an active traffic warning (TA or RA) and the aircraft is above 500' AGL. During a traffic warning, the traffic thumbnail scale automatically adjusts in multiples of 2 NM (2 NM, 4NM, or 6NM) to optimally display the traffic. Since the traffic thumbnail is mutually exclusive with the mini map, it also disappears in unusual attitude mode.

Figure T-6: Traffic Thumbnail

T 4. Dedicated Traffic Page

When selected, a traffic page is available based roughly on the appearance of a TCAS display and has the following elements.

T 4.1. MFD Page (PAGE) Menu

TRAFFIC: Shows the Traffic page. (See § T 1.)

T 4.2. Traffic Display Format



Figure T-7: Traffic Display Format

Traffic page is a centered display format with the ownship symbol centered and data displayed out to an equal distance in all directions. When the AHRS is in DG Mode, "DG" appears to the right of the ownship symbol.

T 4.3. Traffic Page Screen Range

Screen ranges are available (all distances represent the distance from the ownship symbol to the compass rose): 5NM, 10NM, and 20NM. A TCAS range ring is centered upon the ownship symbol to help judge range to

displayed symbols with a 3NM radius in 5NM and 10NM ranges, has a radius of half the range in 20NM, 50NM, and 100NM ranges, and is presented on the TCAS range ring (e.g., 3NM, 10NM, 25NM, or 50NM).

T 4.4. Compass Rose Symbols



Normal Mode



True North Mode

Figure T-8: Traffic Page Compass Rose Symbols

The compass rose is aligned with either magnetic north or true north depending upon the status of the true north discrete input. A digital heading readout and pointer aligned with the longitudinal axis of the ownship symbol appears on the compass rose boundary circle. Compass rose symbols are as specified in Section 3 Display Symbology. A green dashed lubber line connects the center of the aircraft symbol and the track pointer.

If a target altitude is set and not captured, an altitude capture predictor arc is displayed on the lubber line at a point corresponding with predicted climb or descent distance (based upon current VSI). A top of descent symbol is shown at the point where a VNAV descent is predicted to commence. The track pointer, lubber line, altitude capture predictor arc, and top of descent symbol are not displayed when groundspeed is less than 30 knots. A pilot-settable heading bug geometrically interacting with the heading pointer appears on the compass rose. A magenta, star-shaped waypoint pointer is displayed on the heading scale at a point corresponding with the active waypoint and turns amber (yellow) in the event of GPS LON caution.

T 4.5. Clock and Options

13:38:50Z
TRFC ALL

Zulu Time

15:40:29L
TRFC ALL

Local Offset Time

Figure T-9: Clock and Options

The following are displayed in the upper right corner of traffic page.

Table T-5: Clock and Options

Feature	Options	Notes
Zulu Time or Local Offset	hh:mm:ssZ hh:mm:ssL	Synchronized with the GPS/SBAS constellation.

Table T-5: Clock and Options

Feature	Options	Notes
Traffic Status	Enabled or Disabled	If traffic is disabled, overlying red "X". When enabled, traffic altitude filtering is as follows (see Table T-4). AUTO = TRFC AUTO ABOVE = TRFC ABV BELOW = TRFC BLW NORMAL = TRFC NORM ALL = TRFC ALL
ADS-B Traffic Vector Length		Length of traffic vector annunciated as VECT## (traffic vector length in minutes)

T 4.6. Fuel Totalizer/Waypoint Distance Functions



As defined in Section 3 Display Symbology.

Figure T-10: Fuel Totalizer/Waypoint Distance Functions

T 4.7. Active Flight Plan Path/Manual Course/Runways

When there is an active flight plan and automatic GPS/ SBAS OBS setting, the flight plan path, when selected, is shown in correct relationship to the ownship symbol. The active flight plan path depiction meets all GPS/SBAS path definition requirements and matches the lateral navigation guidance on the PFD (GPS/SBAS CDI in automatic OBS mode, skyway boxes, and mini map). Active flight plan path fly-over waypoints symbols are distinct from fly-by waypoints and consist of the waypoint symbol within a circle. When there is a parallel offset, the active flight plan path depicts the parallel offset path, and the original flight plan path is shown with haloed gray dashed lines.

When there is an active waypoint and manual GPS/SBAS OBS setting, the course through the waypoint is shown as a pointer centered on the waypoint and matches the lateral navigation guidance on the PFD (GPS/SBAS CDI in manual OBS mode, skyway boxes, and mini map).

The active flight plan path's active leg/manual course and active waypoint are magenta and turn amber (yellow) in the event of a GPS LON caution. The traffic page displays airport runways in correct relationship and scale to the ownship symbol.

When traffic source is ADS-B, traffic vectors and aircraft identification data are shown. The traffic vector is a line connecting the traffic's current position with the predicted position based on its current track and groundspeed. The prediction time, in minutes, is pilot-selectable. Aircraft identification (e.g. aircraft registration number or scheduled airline flight number) is text located near the traffic symbol in the same color as the traffic symbol.

T 5. MFD Traffic Format Menu

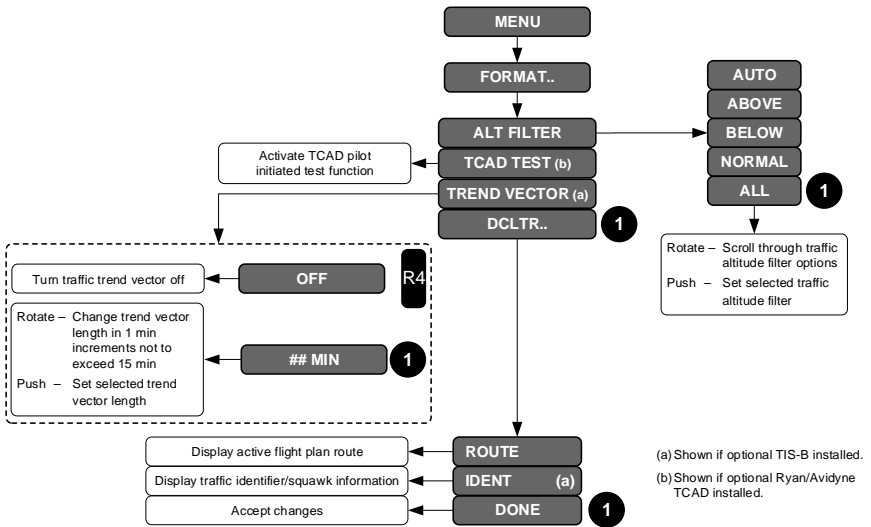

Figure T-11: MFD Traffic Format Menu

Upon selecting the MFD format menu, **FORMAT (R8)**, a list appears with the following options:

- 1) **ALT FILTER**: Sets traffic altitude filter to **AUTO**, **ABOVE**, **BELOW**, **NORMAL**, or **ALL**.
- 2) **TCAD TEST**: Activates test function when Ryan/Avidyne TCAD.
- 3) **TREND VECTOR**: When TCAS flag is TIS-B, sets traffic trend vector length in minutes. **OFF (R4)** turns off traffic trend vector.
- 4) **DCLTR..**: Activates option list.
 - a) **ROUTE**: Toggles display of active flight plan route.
 - b) **IDENT**: When EFIS is configured for TIS-B, toggles traffic identifier/squawk information.



This example shows “TEST XX” for aircraft identifiers. The actual aircraft shows actual aircraft identification.

Figure T-12: MFD Traffic IDENT (FORMAT) Menu

T 6. Fault Display (FAULTS) Menu

If traffic enabled, loss of communications with traffic sensor (TRFC) is indicated with an X in place of “OK.”



T 7. Menu Synchronization

Section 5 Menu Functions and Step-by-Step Procedures for information.

Table T-6: Menu Synchronization

Menu Parameter	Notes
<i>The following menu parameters are synchronized across all displays at all times. These are bugs and fundamental aircraft values that should never have independence.</i>	
Traffic Filter Setting	
<i>The following menu parameters are only synchronized onside. These parameters are usually sensor selections or PFD options used to keep the appearance of any pilot's PFD consistent in the case of PFD reversion. The onside characteristic means that individual pilots can still adjust their PFD settings to their preference.</i>	

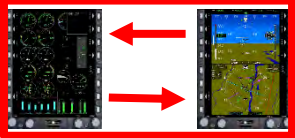
Table T-6: Menu Synchronization

Menu Parameter	Notes
	
PFD Traffic Thumbnail Show Flag	
PFD Traffic Show Flag	
<p><i>The following menu parameters are independent between displays. These are used to support non-PFD display options to give the pilot maximum MFD operating flexibility. Note that some of these parameters are also independent between top and bottom 680 MFD areas as specified in the notes.</i></p>	
	
<p><i>The following menu parameters are independent between displays. These are used to support non-PFD display options to give the pilot maximum MFD operating flexibility.</i></p>	
MFD Traffic Page Settings	Independent between top and bottom 680 MFD areas
MFD MAP Function Declutter (Show Traffic)	

Remote Bugs Panel (RBP)

RBP 1. Remote Bugs Panel

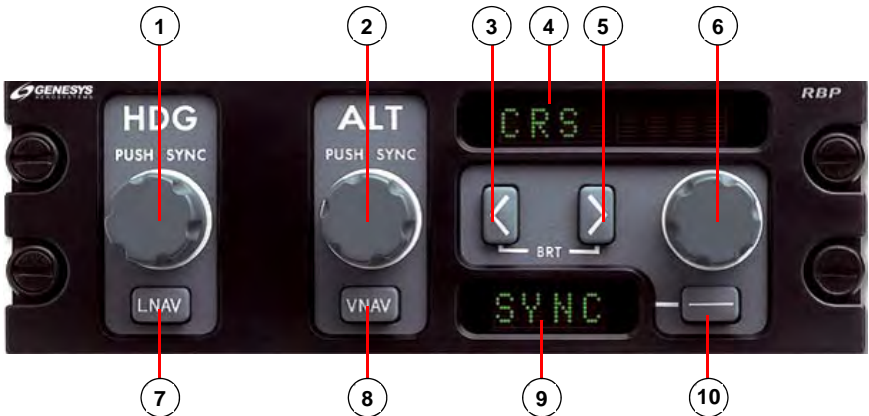

1) Increase/decrease HDG bug – Push to synchronize to current heading	2) Increase/decrease target altitude – Push to synchronize to current altitude
3) Moves through "Set" options – press both arrows simultaneously to place into brightness dimming mode	4) Main display – Indicates course, bug, angle, height, and minimums to be set with multifunction encoder
5) Moves through "Set" options – Press both arrows simultaneously to place into brightness dimming mode	6) Multifunction encoder – Increase/decrease value indicated in main display
7) LNAV – Switches autopilot roll steering between LNAV and HDG sub-modes	8) VNAV – Switches autopilot pitch steering between VNAV and target altitude sub-modes
9) Option display – Toggles function value in main display	10) Option button – Toggles function displayed in option display (also exits brightness dimming mode)

Figure RBP-1: Remote Bugs Panel

The Remote Bugs Panel (RBP) promotes ease of operation while minimizing pilot workload complexity by providing dedicated controls for frequently used bugs and controls for setting IDU parameters as defined in Table RBP-1.

The heading (HDG) and altitude (ALT) encoders behave similarly as the encoders on the IDU. (See Section 5 Menu Functions and Step-By-Step Procedures for HDG and ALT encoder description)

During initialization, the RBP begins with “GENESYS RBP” on the main and option display screens. To access the internal light sensor control for brightness, press the two arrow buttons simultaneously and rotate the multifunction encoder to make adjustments. Press the Option button to exit the brightness control program and return the RBP to normal operation.

Table RBP-1: Remote Bugs Panel (RBP)

Button/Encoder	Function	Rotate	Push
HDG Encoder	Heading Bug	Increase or decrease	Synchronize to current heading
ALT Encoder	Altitude Bug	Increase or decrease target altitude	Synchronize to current altitude
Multifunction Encoder	GPS Course	Increase or decrease	Synchronize to current bearing to active waypoint
Multifunction Encoder	VOR 1 Course	Increase or decrease	Synchronize to current bearing to the station
Multifunction Encoder	VOR 2 Course		
Multifunction Encoder	Airspeed Bug	Increase or decrease	Synchronize to current airspeed
Multifunction Encoder	Vertical Speed Bug	Increase or decrease	Synchronize to current VSI
Multifunction Encoder	Climb Angle Set	Increase or decrease	Set to 3°
Multifunction Encoder	Descent Angle Set		
Multifunction Encoder	Decision Height Bug	Increase or decrease	Set to 200' AGL
Multifunction Encoder	Minimum Altitude Bug	Increase or decrease	Synchronize to current altitude
Option “---“ Button	GPS Course	N/A	Change OBS mode (manual or automatic)
Option “---“ Button	VOR 1 Course	N/A	No function
Option “---“ Button	VOR 2 Course		

Table RBP-1: Remote Bugs Panel (RBP)

Button/Encoder	Function	Rotate	Push
Option “---“ Button	Airspeed Bug	N/A	Toggle on or off
Option “---“ Button	Vertical Speed Bug	N/A	Toggle on or off
Option “---“ Button	Climb Angle Setting	N/A	No function
Option “---“ Button	Descent Angle Setting	N/A	No function
Option “---“ Button	Decision Height Bug	N/A	Toggle on or off
Option “---“ Button	Minimum Altitude Bug	N/A	Toggle on or off
Arrow Buttons	Function Scroll	N/A	Move through “Set” options. Press both arrow buttons simultaneously to place into dimming mode.
VNAV Button (With autopilot enabled)	VNAV	N/A	Switch autopilot pitch steering and commanded VSI between VNAV sub-mode and target altitude sub-mode
LNAV Button (With autopilot enabled)	LNAV	N/A	Switch autopilot roll steering between LNAV sub-mode and heading sub-mode

WX-500 Lightning Strikes

S 1. WX-500 Data

When selected, the EFIS displays cell mode or strike mode lightning strikes in correct relationship to the ownship symbol with the following limits.

Table S-1: Lightning Strikes

Time or Distance Limit	View
Display scale less than 25 NM	Strikes not shown
More than 3 minutes old	
Strikes less than 20 seconds old	Lightning symbol
Strikes between 20 seconds and 2 minutes old	Large cross symbol
Strikes between 2 and 3 minutes old	Small cross symbol



ND Lightning Display



Strikes Page Display

Figure S-1: Lightning Symbols

The pilot may select either an arced or centered display format.

Arced: Ownship displaced toward the bottom of the screen. Strike data are displayed in a larger scale while displaying all data within range ahead of the aircraft.

Centered: Ownship symbol is in the center of the page with navigation data is displayed out to an equal distance in all directions.

The strikes page has Strikefinder markings aligned with either magnetic north or true north depending upon the status of the true north discrete input. When the AHRS is in DG mode, "DG" appears to the right of the ownship symbol.

S 2. Dedicated Strikes Page

S 2.1. MFD Page (PAGE) Menu

STRIKES: Shows the strikes page.

S 2.1.1. MFD STRIKES Page (Step-By-Step)



- 1) Push **1** or **2** and rotate to **STRIKES** and push to enter.



- 2) Example shows MFD with **STRIKES** in bottom area.

S 2.2. Page Screen Range

The following screen ranges may be selected with all distances representing the distance from the ownship symbol to the Strikefinder markings: 12.5 NM, 25 NM, 50 NM, 100 NM, and 200 NM. The range ring is centered upon the ownship symbol to help judge range to displayed symbols. It has half the radius of the Strikefinder markings displayed indicating the range corresponding to the radius of the range ring such as (1.5 NM, 25 NM, 50 NM, and 10 NM.) The range ring is completely visible in arced display format for the pilot to ascertain the current strikes page setting.

S 2.3. Air Data and Groundspeed

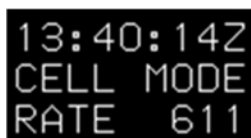

Figure S-2: Air Data and Groundspeed in Upper Left Corner

S 2.4. Clock and Options



Clock with Local Offset Time



Clock with Zulu Time

Figure S-3: Clock and Options

The following are displayed in the upper right corner of the page:

- 1) **Zulu Time or LCL Time:** As specified in Section 3 Display Symbology.
- 2) **WX-500 Status:** When selected, displays cell mode lightning strikes in correct relationship to the ownship symbol with the limits found in Table S-2.

Table S-2: WX-500 Status

Condition	Annunciation
System Normal, Cell Mode	CELL MODE annunciates mode RATE ### depicts strike rate
System Normal, Strike Mode	STRK MODE annunciates mode RATE ### depicts strike rate
System Failed with "Show Full Sensor Status Flag" enabled in EFIS Limits	STRIKES overlaid with red "X" Strike symbols removed
System in Test Mode	STRK TST shown Strike symbols removed

A new strike rate value is calculated every five seconds during normal operation, based upon strikes within the selected display range. The number of fresh strikes (less than 20 seconds old) is used to generate a strike rate representing strikes per minute. Strike rate increases are displayed immediately upon calculation, while decreases in strike rate are damped. Activating the strike clear function resets the strike rate to zero.

S 2.5. Active Flight Plan Path/Manual Course/Runways

When there is an active flight plan and the GPS/SBAS OBS setting is automatic, the flight plan path is shown on the strikes page in correct relationship to the ownship symbol.



When there is an active waypoint and the GPS/SBAS OBS setting is manual, the course through the waypoint is shown as a pointer centered on the waypoint. The pointer matches the lateral navigation guidance on the PFD (GPS/SBAS CDI in manual OBS mode, skyway boxes, and mini map).

Figure S-4: Active Flight Plan Path/Manual Course/Runways

The active flight plan path's active leg/manual course and active waypoint are magenta but turn amber (yellow) in the event of a GPS LON caution. The strikes page displays airport runways in correct relationship and scale to the ownship symbol.

S 2.6. Fuel Totalizer/Waypoint Distance Functions



As defined in Section 3 Display Symbology.

Figure S-5: Fuel Totalizer/Waypoint Distance Functions

S 3. MFD Faults Display (FAULTS) Menu

If WX-500 is enabled, loss of communications with the WX-500 is indicated with an "X" in place of "OK."

S 4. MFD Page First-Level Option Descriptions

CLR STRKS (L2): With WX-500 enabled, **CLR STRKS** activates the strike clear option on applicable MFD pages.

S 5. MFD Strikes Format (FORMAT) Menu

Upon selecting the MFD format menu, **FORMAT (R8)** when in the strikes page, the following option list appears:

- 1) **CENTER/ARC:** Toggles centered and arced display format.
- 2) **STRK MODE/CELL MODE:** Toggles strike and cell mode.
- 3) **STRK TEST:** Activates the WX-500 test function
- 4) **DCLTR..:** Activates option list to toggle active flight plan route.

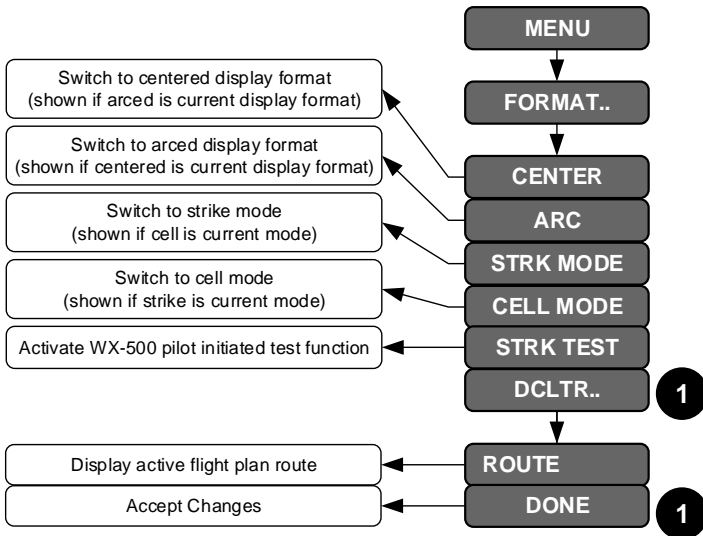

Figure S-6: MFD Strikes Format (FORMAT) Menu



S 6. Menu Synchronization

Section 5 Menu Functions and Step-by-Step Procedures for additional information.

Table S-3: Menu Synchronization

Menu Parameter	Notes
<p><i>The following menu parameters are only synchronized onside. These parameters are usually sensor selections or PFD options used to keep the appearance of any pilot's PFD consistent in the case of PFD reversion. The onside characteristic means that individual pilots can still adjust their PFD settings to their preference.</i></p>	
MFD Strike (WX-500) Page Settings	
<p><i>The following menu parameters are independent between displays. These are used to support non-PFD display options to give the pilot maximum MFD operating flexibility. Note that some of these parameters are also independent between top and bottom 680 MFD areas as specified in the notes.</i></p>	

Table S-3: Menu Synchronization

Menu Parameter	Notes
	
MFD Strike (WX-500) Page Settings	Independent between top and bottom 680 MFD areas

Datalink

D 1. Datalink Symbology

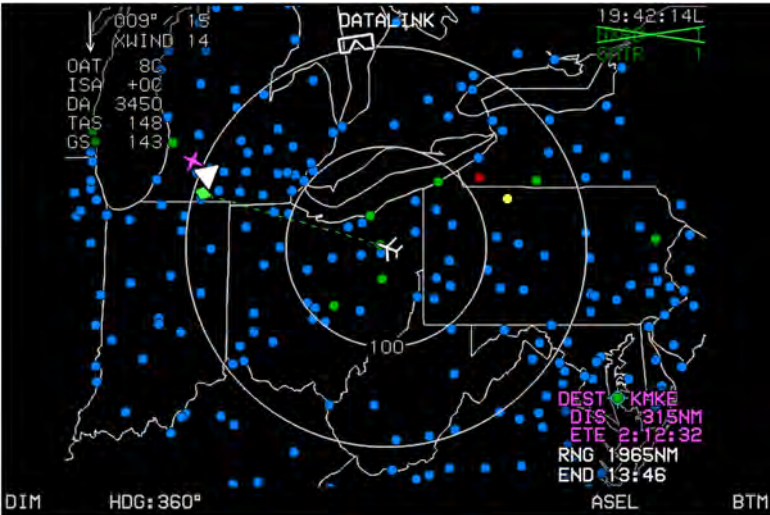

Figure D-1: Datalink Symbology with G METAR On

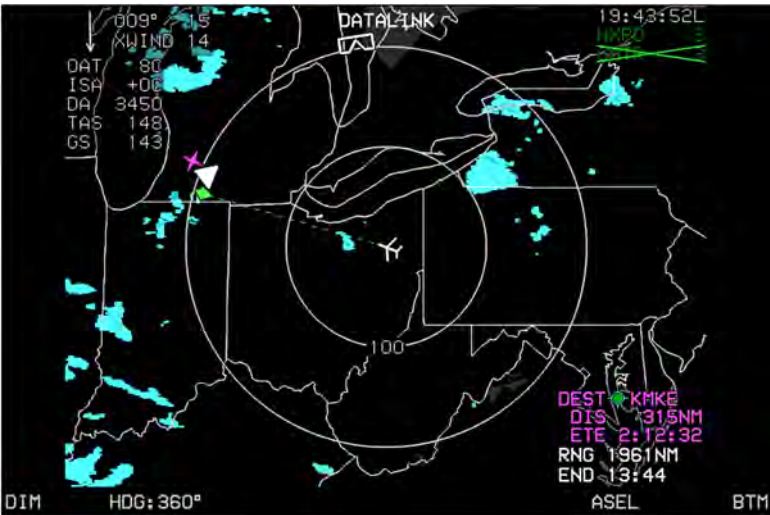

Figure D-2: Datalink Symbology with NEXRAD On

NEXRAD data is displayed in correct relationship as colored regions of precipitation using the following coloring convention.

Table D-1: ADS-B Data

NEXRAD Data	Available if included in user subscription.
Graphical METAR Data	Available if textual METAR data is included in user subscription. Derived from textual METAR data using EFIS algorithm.

Table D-2: Datalink NEXRAD Data

Color	Meaning
Gray Shading	Areas beyond the limits of radar coverage or areas with missing data
Magenta	Rain \geq 50dBZ
Red	Rain \geq 45dBZ and $<$ 50dBZ
Light Red	Rain \geq 40dBZ and $<$ 45dBZ
Amber (Yellow)	Rain \geq 30dBZ and $<$ 40dBZ
Green	Rain \geq 20dBZ and $<$ 30dBZ
Cyan	Snow \geq 20dBZ
Light Cyan	Snow \geq 5dBZ and $<$ 20dBZ
Magenta	Mixed Precipitation \geq 20dBZ (Area is distinguishable from rain \geq 50dBZ by graphical context)
Light Magenta	Mixed Precipitation \geq 5dBZ and $<$ 20dBZ

Graphical METARs are displayed in correct relationship to the ownship symbol as a large color-filled circle as follows.

If the airport has an available datalinked METAR, the circular part of the airport symbol is colored-fill with the following coloring convention.

Table D-3: Graphical METAR Symbols

Color	Meaning
Sky Blue	Visual Flight Rules (VFR)
Green	Marginal Visual Flight Rules (MVFR)
Amber (Yellow)	Instrument Flight Rules (IFR)
Red	Low Instrument Flight Rules (LIFR)
Magenta	Less than Category 1 Approach Minimums
Black	No Data

Table D-4: Graphical METARS (GMETARS) Screen Range

Screen Range	Display
50 NM	All GMETARS with Airport Symbol and ID
100 NM	All GMETARS with Airport Symbol only
200 NM	All GMETARS
400 NM	VFR GMETARS are decluttered
800NM and 1,600 NM	VFR and MVFR GMETARS are decluttered

Graphical METARs are also displayed in the menu system “nearest airport,” “nearest weather,” and “info” functions.



Figure D-3: NRST Airport INFO

Graphical weather conditions data are displayed in the menu system “info” function as large colored squares per the following convention.

Table D-5: Datalink Graphical METAR Precipitation

Color	Meaning
Sky blue	No significant precipitation
Green	Rain
White	Snow
Red	Hazardous weather
Right half gray	Obscuration to visibility
Small black square centered in large square	High wind
Black	No data

Textual METAR and TAF data are displayed when appropriate in the menu system “info” function. Time of observation and forecast are contained within the text.

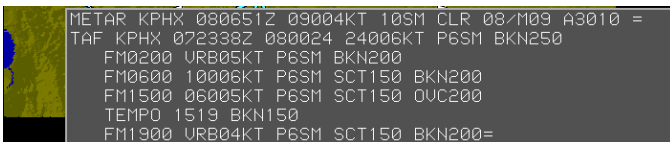

Figure D-4: METAR and TAF Report for KPHX

D 2. Dedicated Datalink Page

D 2.1. MFD Page Menu

DATALINK: Shows the Datalink page.

D 2.2. Ownship Symbol



When not panning with AHRS in the DG mode, “DG” appears right of the ownship symbol. The datalink page is always displayed in a north-up orientation with a boundary circle in place of the compass rose. If not in pan mode, the ownship symbol is aligned with the aircraft heading.

Figure D-5: Datalink Symbology Ownship Symbol

D 2.3. Datalink Page Legend

G METAR		NEXRAD	
● UFR	● MUFR	■ NO COVERAGE	■ ABOVE 50DB
● IFR	● LIFR	■ 45-50DB	■ 40-45DB
● BLW CATI	● NO DATA	■ 30-40DB	■ 20-30DB

Figure D-6: ADS-B Datalink Legend

D 2.4. Air Data and Groundspeed

Air data and groundspeed are displayed in the upper left corner of the datalink page as specified in Section 3 Display Symbology.

D 2.5. Clock and Options



Zulu Time

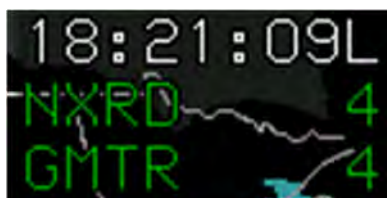

Local Time

Figure D-7: Clock/Options

The following are displayed in the upper right corner :

- 1) **Zulu Time or LCL Time:** As in Section 3 Display Symbology.
- 2) **Datalink Weather Status:** When status of NEXRAD, graphical METARs, and lightning ground strike data are displayed as follows.

Table D-6: Datalink NEXRAD Status

Condition	Status Annunciation	
	*NEXRAD	Graphical METAR
Never completely downlinked	No Annunciation	
Downlinked within last 5 minutes and selected for display (*if installed, weather radar deselected from display). "Show Full Sensor Status Flag" enabled.	"NXRD ##" in green. ## is age in minutes. NEXRAD shown.	"GMTR ##" in green. ## is age in minutes. G METARS shown.
Downlinked within last 5 minutes and deselected from display (*if installed, weather radar selected for display). "Show Full Sensor Status Flag" enabled.	"NXRD ##" in green. ## is age in minutes. "NXRD ##" overlaid with green "X" NEXRAD not shown.	"GMTR ##" in green. ## is age in minutes. "GMTR ##" overlaid with green "X" G METARS not shown.
Not downlinked within last 5 minutes but downlinked within last 10 minutes and selected for display (*if installed, weather radar deselected from display). "Show Full Sensor Status Flag" enabled.	"NXRD ##" in amber (yellow). ## is age in minutes. NEXRAD shown.	"GMTR ##" in amber (yellow). ## is age in minutes. G METARS shown.
Not downlinked within last 5 minutes but downlinked within last 10 minutes and deselected from display (*if installed, weather radar selected for display). "Show Full Sensor Status Flag" enabled.	"NXRD ##" in amber (yellow). ## is age in minutes. "NXRD ##" overlaid with green "X" NEXRAD not shown.	"GMTR ##" in amber (yellow). ## is age in minutes. "GMTR ##" overlaid with green "X" G METARS not shown.
Not downlinked within last 10 minutes but downlinked within last 75 minutes and selected for display (*if installed, weather radar deselected from display).	"NXRD ##" in red. ## is age in minutes. NEXRAD shown.	"GMTR ##" in red. ## is age in minutes. G METARS shown.

Table D-6: Datalink NEXRAD Status

Condition	Status Annunciation	
	*NEXRAD	Graphical METAR
Not downlinked within last 10 minutes but downlinked within last 75 minutes and deselected from display (*if installed, weather radar selected for display). "Show Full Sensor Status Flag" enabled.	"NXRD ##" in red. ## is age in minutes. "NXRD ##" overlaid with green "X" NEXRAD not shown.	"GMTR ##" in red. ## is age in minutes. "GMTR ##" overlaid with green "X" G METARS not shown.
Not downlinked within last 75 minutes (timed-out). "Show Full Sensor Status Flag" enabled.	"NXRD XX" in red "NXRD XX" overlaid with red "X" NEXRAD not shown.	"GMTR XX" in red "GMTR XX" overlaid with red "X" G METARS not shown.

D 2.6. Datalink Page Screen Orientation



Figure D-8: Datalink Page Screen Range

When selected, the following screen ranges (all distances represent distance from the ownship symbol to the boundary circle) are available. Radius of the range ring is presented on the inner range ring with the outer ring representing double the value of the inner ring.

Table D-7: Datalink Page Screen Ranges

Ownship to Boundary Circle	Radius Range Values
50 NM	25 NM
100 NM	50 NM
200 NM	100 NM
400 NM	200 NM
800 NM	400 NM
1,600 NM	800 NM

D 2.7. Boundary Circle Symbols

**Figure D-9: Boundary Circle Symbol**

A white triangular heading pointer aligned with the longitudinal axis of the ownship symbol appears on the boundary circle with a green diamond-shaped track pointer aligned with the aircraft's track across the earth. A green dashed lubber line connects the center of the aircraft symbol and the track pointer.

If a target or VNAV altitude is set and not captured, an altitude capture predictor arc is displayed on the lubber line at a point corresponding with predicted climb or descent distance (based upon current VSI). The track pointer, lubber line, and altitude capture predictor arc are not displayed when groundspeed is less than 60 knots. A pilot-settable heading bug geometrically interacting with the heading pointer appears on the boundary circle. A magenta, star-shaped waypoint pointer displayed on the boundary circle at a point corresponds with the active waypoint. The waypoint pointer turns amber (yellow) in the event of GPS LON caution. Boundary circle symbols are not drawn when in pan mode.

D 2.8. Active Flight Plan Path/Manual Course/Runways

When there is an active flight plan and automatic GPS/SBAS OBS setting, the flight plan path, when selected, is shown in correct relationship to the ownship symbol. The active flight plan path depiction meets all GPS/SBAS path definition requirements and matches the lateral navigation guidance on the PFD (GPS/SBAS CDI in automatic OBS mode, skyway boxes, and mini map). Active flight plan path fly-over waypoints symbols are distinct

from fly-by waypoints and consist of the waypoint symbol within a circle. When there is a parallel offset, the active flight plan path depicts the parallel offset path, and the original flight plan path is shown with haloed gray dashed lines.

When there is an active waypoint and manual GPS/SBAS OBS setting, the course through the waypoint is shown as a pointer centered on the waypoint and matches the lateral navigation guidance on the PFD (GPS/SBAS CDI in manual OBS mode, skyway boxes, and mini-map).

The active flight plan path's active leg/manual course and active waypoint are magenta but turn amber (yellow) in the event of a GPS LON caution. The datalink page displays airport runways in correct relationship and scale to the ownship symbol.

D 2.9. Borders

National and United States state borders are drawn in white in correct relationship to the ownship symbol.

D 2.10. Pan Mode

Use the pan mode to change the location of the center of the page away from current location and view weather conditions along the route of flight and at the intended destination or alternate destination. When pan mode is active, rotate **1** (or **2** as applicable) to pan north, south, east, and west. When pan mode is active, a line is drawn from the map center to the aircraft's current position, and bearing and distance to the map center is always displayed above the ownship symbol when the aircraft is more than 0.5 NM away. If referenced to magnetic north, (as specified in Section 3 Display Symbology) when panning, the nearest displayed graphical METAR symbol within the inner range ring is highlighted with a flashing circle. When such a point is highlighted, dedicated buttons are present to allow the pilot to view and hide the waypoint information (including datalink weather information) associated with that point.

D 3. MFD Datalink Format Menu

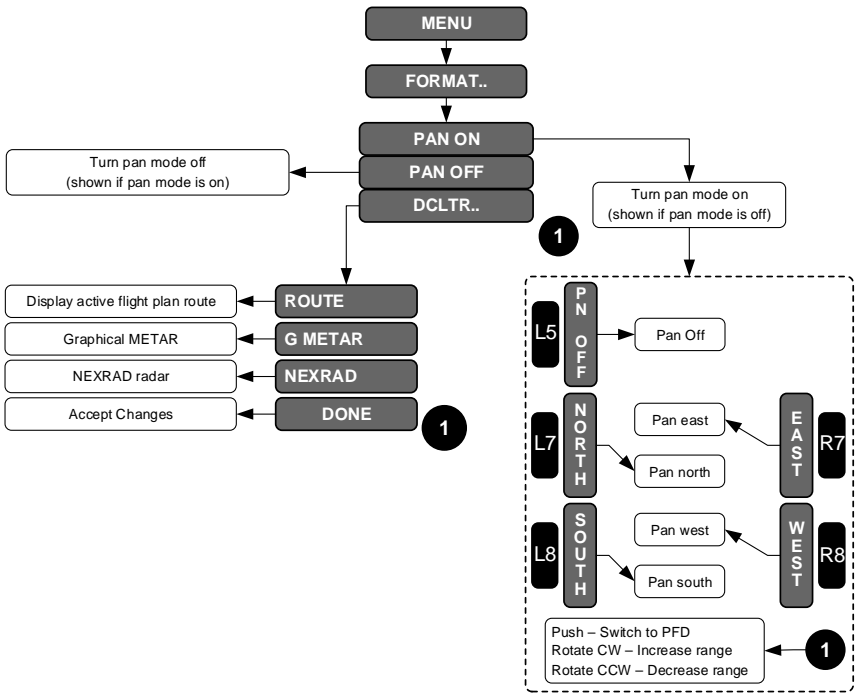

Figure D-10: MFD Datalink Format Menu

- 1) **PAN ON/PAN OFF:** Toggles Datalink page pan mode.
- 2) **DCLTR..:** Activates option list.
 - a) **ROUTE:** Toggles showing the active flight plan route on the Datalink page.
 - b) When datalink weather products are available for display, list of individual datalink weather products appears in the selection box, e.g., **G METAR, NEXRAD.**

D 3.1. MFD DATALINK Page (Step-By-Step)



- 1) Push **1** or **2** and rotate to **DATALINK** and push to enter.



- 2) Example shows MFD with DATALINK on bottom area.



- 3) Press **MENU (R1)** then **FORMAT (R8)** to format DATALINK page.

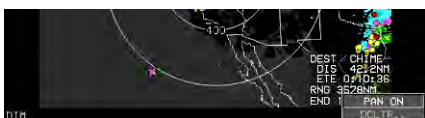

- 4) Rotate **1** to **PAN ON** or **DCLTR**.. Push to enter.

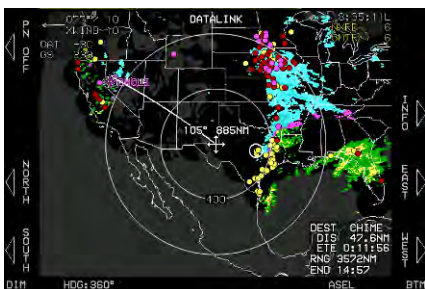

- 5) In pan mode, press **NORTH (L7)**, **SOUTH (L8)**, **EAST (R7)**, or **WEST (R8)** to move aircraft in desired direction.

If selected in MFD top area:
NORTH (L3), **SOUTH (L4)**,
EAST (R3), or **WEST (R4)**.

D 4. Top-Level Menu Automatic Pop-Up Function Descriptions

See Section 5 Menu Functions and Step-by-Step Procedures for top-level menu option descriptions. Soft menu tiles appear adjacent to buttons under the specified conditions.

Table D-8: Top-Level Auto Pop-Up Function Descriptions

Note		Tile Legend and Action in Order of Precedence
1	2	
L1	L5	When Datalink page with pan mode enabled, PN OFF appears. Press to disable pan mode.
L2	L6	When Datalink page with: (a) pan mode enabled; (b) information for the nearest highlighted waypoint is shown; and (c) airport weather information is present in the information block; WX appears. Press to display textual METAR and TAF data for the airport.

Table D-8: Top-Level Auto Pop-Up Function Descriptions

Note		Tile Legend and Action in Order of Precedence
1	2	
L3	L7	When Datalink page with pan mode enabled, NORTH appears. Press to shift center of page in the specified direction.
L4	L8	When Datalink page with pan mode enabled. SOUTH appears. Press to shift the center of the page in the specified direction.
R2	R6	When ND page or Datalink page with pan mode enabled, INFO or HIDE appears. Press to toggle information for nearest highlighted waypoint.
R3	R7	When Datalink page with pan mode enabled, EAST appears. Press to shift the center of the page in the specified direction.
R4	R8	When Datalink page with pan mode enabled, WEST appears. Press to shift the center of the page in the specified direction.
Note 1: Function tied to page in top area.		
Note 2: Function tied to page in bottom area or transmit enabled.		

D 5. MFD Page First-Level Option Descriptions

WX LGND (ACTV) (L2): Activates datalink weather legend.

D 6. Active Flight Plan (ACTV) Menu Options

NRST APT (L2): WX LGND and **EXPND WX** are available to show a weather symbol legend and highlighted result METAR and TAF text respectively.

Identifier Entry Box: Highlighted result information may include datalinked weather information when available.

D 7. Information (INFO) Menu

When airport weather information is presented in the information block, **WX LGND (L2)** displays an airport graphical METAR legend, and **EXPND WX (L3)** displays textual METAR and TAF data for the airport.

D 8. MFD Fault Display Menu

Upon selecting the MFD faults menu with ADS-B datalink enabled, an indication of ADS-B position validity (ADSB POSN), indication of whether ADS-B receiver maintenance is required (ADSB MAINT), and indication the conflict situational awareness algorithm is working (ADSB CSA) appear.

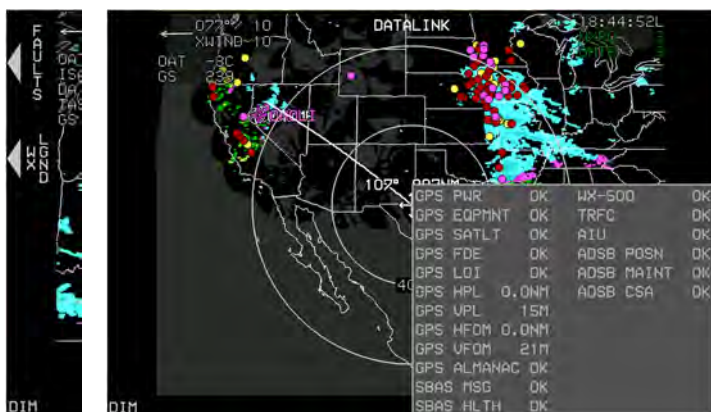

Figure D-11: FAULTS Menu with ADS-B Status

D 9. Menu Synchronization

Section 5 Menu Functions and Step-by-Step Procedures for additional information.

Table D-9: Menu Synchronization

Menu Parameter	Notes
<i>The following menu parameters are independent between displays. These are used to support non-PFD display options to give the pilot maximum MFD operating flexibility. Note that some of these parameters are also independent between top and bottom MFD areas as specified in the notes.</i>	
MFD Datalink Page Settings	Independent between top and bottom MFD areas

Weather Radar

WX 1. Weather Radar

This Weather Radar appendix is primarily for the Honeywell RDR-2100 installed with no external control panel. The EFIS controls the WX RDR from the EFIS PFD bottom display or MFD with WX RDR displayed in the top area or bottom area. Since there is only one RDR-2100 installed in the aircraft, only one display area at a time can show the WX RDR menu.

WARNING:

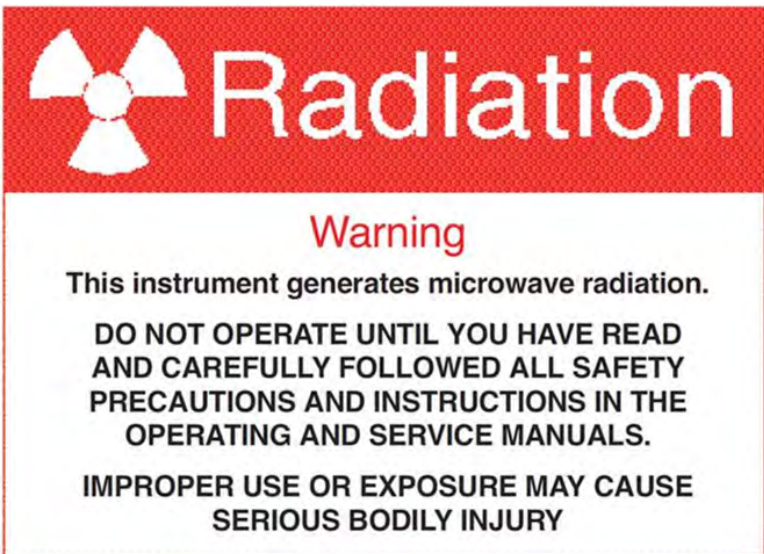

The image shows a radiation warning sign. It features a red background with a white radiation symbol on the left and the word "Radiation" in large white letters on the right. Below this, on a white background, is the word "Warning" in red, followed by the text: "This instrument generates microwave radiation. DO NOT OPERATE UNTIL YOU HAVE READ AND CAREFULLY FOLLOWED ALL SAFETY PRECAUTIONS AND INSTRUCTIONS IN THE OPERATING AND SERVICE MANUALS. IMPROPER USE OR EXPOSURE MAY CAUSE SERIOUS BODILY INJURY".

CAUTION:

Maintain prescribed safe distance when standing in front of operating antenna. (Reference FAA Advisory Circular #20-68)

Never expose eyes or any part of the body to an unterminated wave guide.

Weather radar automatically declutters when weather radar returns are selected for display on the map page in correct relationship to the ownship symbol unless inhibited during active FLTA alerts. When weather radar is

WX 2. Top-Level Menu Option Descriptions

WX RDR (R7): If a Weather Radar page is displayed on the PFD, activates the Weather Radar menu for controlling Honeywell RDR-2000/2100.

WX RDR (R3): If a Weather Radar page is displayed on top area of the MFD, activates the Weather Radar menu for controlling Honeywell RDR 2000/2100.

① Encoder: On an MFD (IDU #2, #3 or #4) operating in Normal mode, if the top area is showing the Weather Radar page, rotate **①** to change the display RNG (Direction of rotation is dependent upon EFIS limits settings.)

① Encoder: On a PFD or MFD operating in Normal mode, if the bottom area is showing the Weather Radar page, rotate **①** to change the display RNG, (Direction of rotation is dependent upon EFIS limits settings.)

DCLTR (R8): On the Weather Radar page with declutterable OASIS overlays or in horizontal profile mode, DCLTR activates Weather Radar Declutter menu option.

WX 3. PFD Weather Radar Page Format Menu

Upon selecting WX RDR format menu in the WX RDR page when weather radar type is RDR-2100 without external RCP installed, the following list appears.

- 1) **WX RDR (R7):** Opens **CTRL (L6)** menu.
- 2) **Off (R6):** Turns Weather Radar off.
- 3) **Standby (R7):** Toggles WX RDR to STBY mode, press **ON WXA (L8)** to turn on WX RDR.
- 4) **Test (R8):** Toggles radar into TEST mode, press **ON WX (L8)** to return to normal operation.
- 5) **ON WX (L8):** Toggles WX ON, WXA, or GMAP.
- 6) **Vertical Profile (L7):** Toggles vertical profile ON/OFF. (When VP is OFF, horizontal profile is ON.)

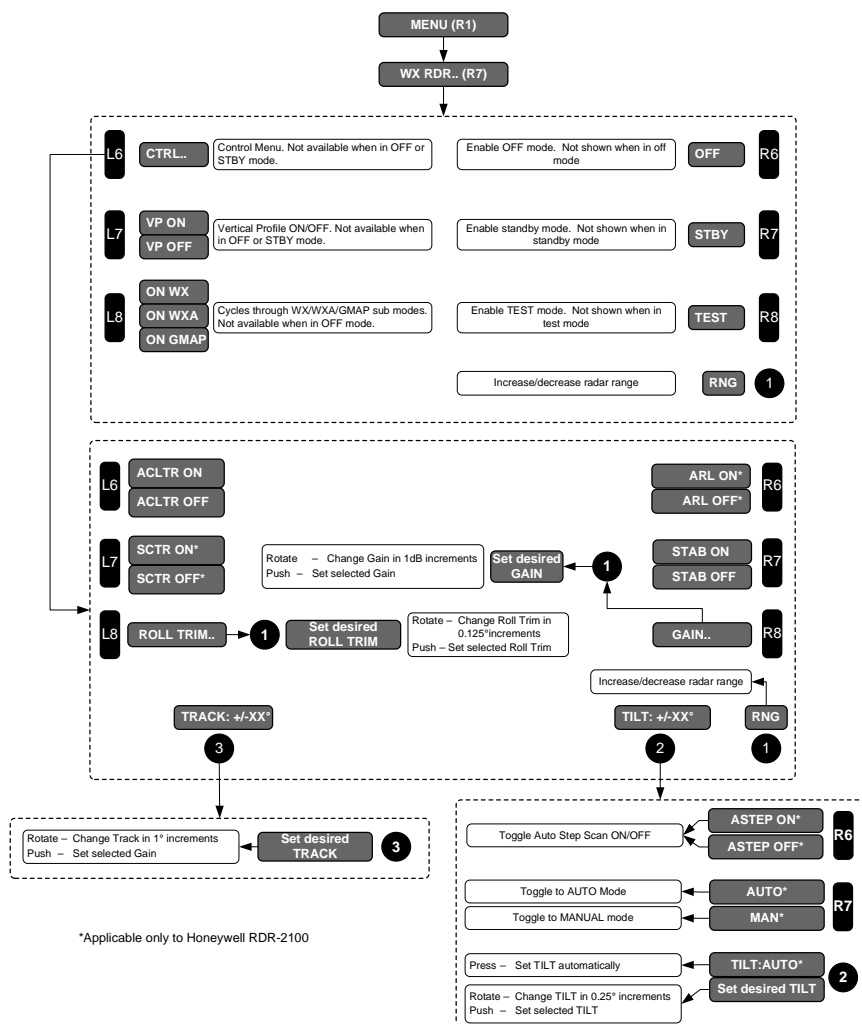

Figure WX-3: PFD WX RDR Format Menu

NOTE:

The weather radar modes are mutually exclusive and therefore selecting one turns off the other modes with the exception of vertical profile, which appears in the selection box only when the selected weather radar mode is not OFF or STBY.

- 1) **WX RDR (R7)**: Turns on Weather Radar
- 2) **CTRL (L6)**: Activates a list to control live parameters as follows:
 - a) **ACLTR ON (L6)**: Toggles anti-clutter option between on and off.
 - b) **ASTEP ON (R6)**: Toggles Auto Step Scan on or off. Begin by adjusting tilt to $+15^\circ$ or -15° .
 - c) **ARL ON/OFF (R6)**: Toggles automatic range limit option on and off.
 - d) **SCTR ON/OFF (L7)**: Toggles sector scan option on and off.
 - e) **STAB ON/OFF (R7)**: Toggles stabilization mode on or off.
 - f) **ROLL TRIM (L8)**: Changes roll trim in increments of 0.125° between $+3.875^\circ$ and -4.000° .
 - g) **GAIN (R8)**: Change radar gain in increments of 0.5 dB between 0-31.5 dB.
 - h) **TRACK ②**: Rotate CW to increase and CCW to decrease changes in track in increments of 1° in the following limits settings.
 - i) Scan width 80° ($\pm 40^\circ$)
 - ii) Scan width 90° ($\pm 45^\circ$)
 - iii) Scan width 100° ($\pm 50^\circ$)
 - iv) Scan width 120° ($\pm 60^\circ$)
- 3) **TILT ②**: Toggles tilt mode between auto tilt (RDR-2100 only) and manual tilt. Also toggles auto-step-scan option between on and off. When in manual tilt mode, changes tilt angle in increments of 0.25° .
- 4) **RNG ①**: See § WX 3.1.
- 5) **DCLTR: ROUTE** toggles active flight plan route.

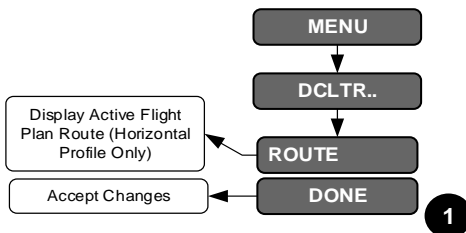

Figure WX-4: WX RDR Declutter (DCLTR) Menu

In a horizontal depiction, the weather page uses an arced format with the ownship symbol centered in the bottom of the display with the weather area depicted as an arc ahead of the ownship symbol.

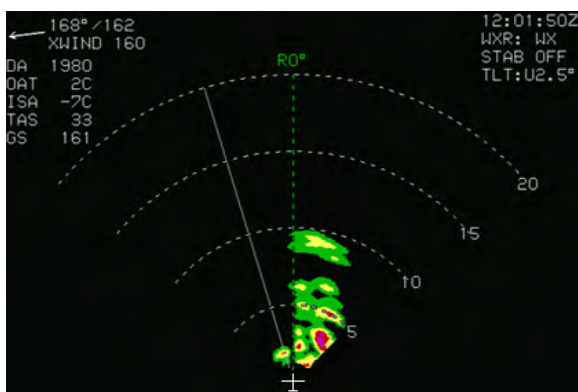

Figure WX-5: Radar Image in Arc Format

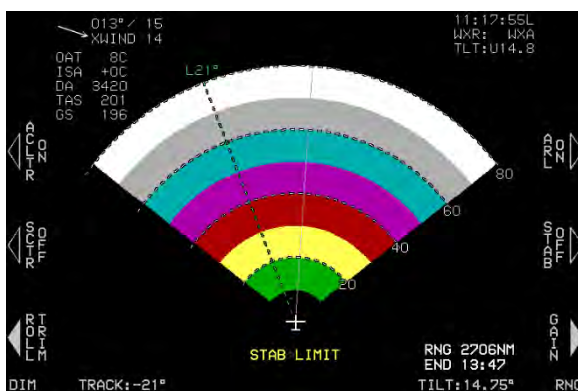

Figure WX-6: Radar Image in Arc Format (STAB LIMIT)

In a profile depiction, the weather page uses an arced format with the ownship symbol centered on the left side of the display and the weather area depicted as an arc to the right of the ownship symbol.

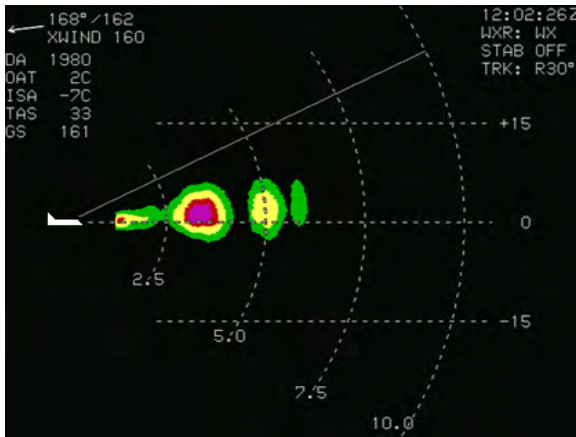

Figure WX-7: Radar Image in Profile Depiction

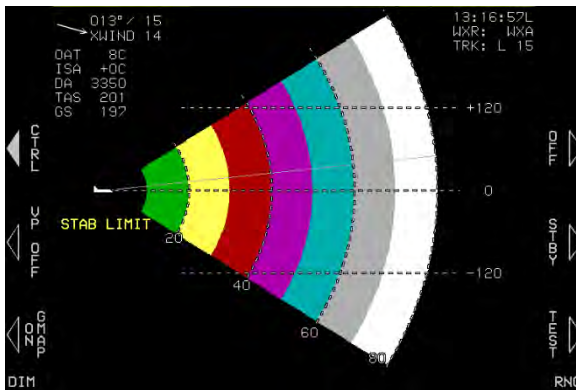

Figure WX-8: Radar Image in Profile Depiction (STAB LIMIT)

To select profile depiction, use the weather radar control panel EFIS menu. The EFIS ensures at least one weather radar-enabled page is showing the weather radar page prior to entering into profile depiction and disables profile depiction if the pilot sets the pages for no weather radar page on any weather radar-enabled page. The purpose is to maximize the availability of weather radar information on the ND page. The ND page only shows a horizontal depiction and disables profile depiction if the weather radar mode is set to off or standby via radar control panel.

WX 3.1. Weather Page Screen Range

Weather page screen range is pilot-selectable with either **1** (RDR-2000 or RDR-2100 weather radar types) or a control panel directly attached to the weather radar receiver-transmitter. Weather page screen range is displayed as a series of equidistant dashed arcs centered upon the ownship symbol to help judge range to the displayed weather radar returns. All distances represent the distance from the ownship symbol to the outer dashed arc: 5NM, 10NM, 20NM, 40NM, 80NM, 160NM, 240NM, and 320NM.

For most screen ranges, there are four equidistant dashed arcs. Each arc is labeled with distance in nautical miles at its right-most point (horizontal depiction) or bottom-most point (profile depiction). In profile depiction, there are also three horizontal altitude lines drawn relative to the aircraft's altitude to help judge the vertical distance to the displayed weather radar returns. The center line is level with the ownship symbol to represent the aircraft's altitude. The other two lines are equally spaced above and below the center line to represent altitude differences above and below the aircraft. The number of feet above and below the aircraft varies with the selected range to compensate for the radar scan width at the different ranges.

WX 3.2. Track Line

When the weather radar type is RDR-2100 and in horizontal depiction, a dashed track line emanates from the ownship symbol to the outer dashed arc. The value of the track line in whole degrees left or right of aircraft heading is displayed adjacent to the outer end of the track line.

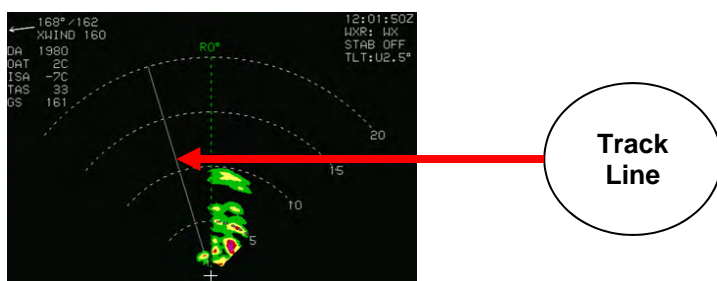

Figure WX-9: Radar Track Line

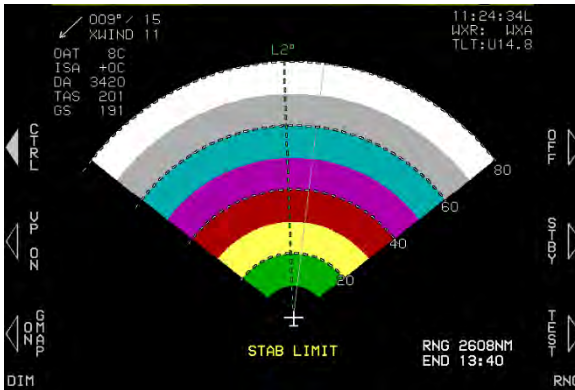

Figure WX-10: Radar Track Line with Menus

WX 3.3. Active Flight Plan Path/Manual Course/Runways

The active flight plan path (when selected), waypoints, and manual course appear, when the weather radar page is showing horizontal depiction. The weather radar page displays airport runways, when the weather radar page is showing horizontal depiction.

Figure WX-11: Radar Active Flight Plan

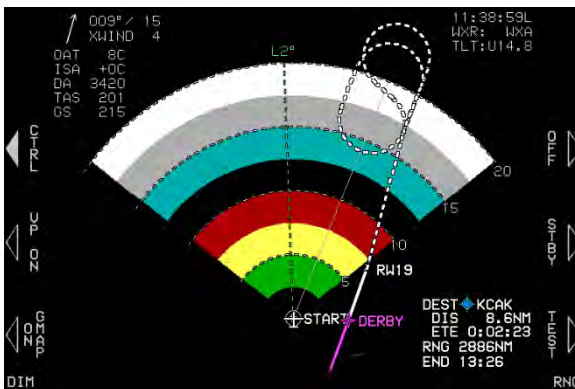

Figure WX-12: Radar Active Flight Plan with Menus

WX 3.4. Weather Radar Return Data

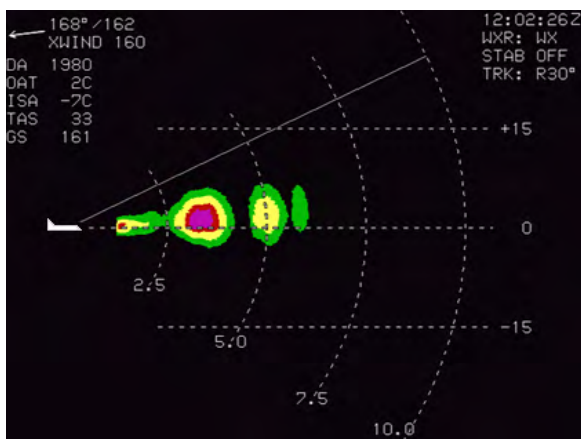

Figure WX-13: Radar Return Data

Weather radar return data are displayed in correct relationship to the ownship symbol as colored regions.

Table WX-2: Weather Radar Return Data

ARINC 453 3-Bit Range Bin	Color	Meaning
000b	BLACK	No returns
001b	GREEN	Low-level weather or low-level ground returns
010b	YELLOW	Mid-level weather or mid-level ground returns
011b	RED	Third-level weather returns. Color is black when in MAP mode.
100b	MAGENTA	Fourth-level weather or third-level ground returns. With RDR-2000 or RDR-2100 weather radar type, color alternates between magenta and black at 1Hz when internal sub-mode is WXA.
101b	CYAN	Automatic range limit returns. Indicates areas of unreliable returns due to radar power absorption.
110b	LIGHT GRAY	Moderate turbulence returns
111b	WHITE	Severe turbulence returns

The following weather radar-specific warnings appear in a conspicuous area adjacent to weather radar return data so they do not conflict with the weather radar return data. Only one warning appears at any given time, with the following order of precedence:

- 1) **WX ALERT:** Weather alert condition is active.
- 2) **TURB ALERT:** Turbulence alert condition is active.
- 3) **STAB LIMIT:** Aircraft attitude has moved to a point where the weather radar antenna can no longer be effectively stabilized.
- 4) **ANT FAULT:** Weather radar antenna is temporarily dislodged by turbulence.

WX 3.5. Air Data and Groundspeed

Displayed as specified in Section 3 Display Symbology.

WX 3.6. Waypoint Distance

Displayed as specified in Section 3 Display Symbology.

WX 3.7. Clock/Options

The following are displayed in the upper right corner:



Figure WX-14: Radar Clock/Options

- 1) **Zulu Time or LCL Time:** As in Section 3 Display Symbology;
- 2) **Weather Radar Mode Annunciation:** As in Table WX-3 and Table WX-4.

Mode	Annunciation
Off	WXR:OFF
Standby	WXR:STBY
Weather only	WXR:WX
Weather alert	WXR:WXA
Ground map	WXR:GMAP

Table WX-3: RDR 2100 Applicability

Mode	Annunciation
Test	WXR:TEST
Not defined	WXR:----

Table WX-4: RDR 2100 Mode Annunciation

Annunciation	Conditions
Overlaid with Red X	Weather radar mode is off or not defined. Cooling fault condition exists. Attitude or range fault condition exists. T/R fault condition exists.
STAB OFF (Stabilization)	Mode annunciation not overlaid with a red "X"; Mode not standby or forced standby; and Weather radar indicates stabilization is off.
TGT ALERT (Target Alert)	Mode annunciation not overlaid with a red "X"; Mode not standby or forced standby; Weather radar presenting horizontal depiction.
"TLT:UXX.X" or "TLT:AUTO" (TILT)	U = Up or Down (either U or D, but not both, may appear – use "U" for 0°); XX.X represents absolute value of the tilt angle in degrees truncated to the nearest tenth; "TLT:AUTO" used where weather radar reports a value of -16°, representing automatic tilt. Weather radar tilt annunciation only appears when all following conditions are true: <ol style="list-style-type: none"> 1) Mode annunciation not overlaid with a red "X"; 2) Mode not standby or forced standby; and 3) Radar not in vertical profile depiction.
TRK:LXX (TRACK)	L = Left or Right (either L or R, but not both, may appear – use "R" for 0°); and XX represents absolute value of the track angle in degrees. Weather radar track annunciation only appears when all following conditions are true: <ol style="list-style-type: none"> 1) Mode annunciation not overlaid with a red "X"; 2) Mode not standby or forced standby; and

Table WX-4: RDR 2100 Mode Annunciation

Annunciation	Conditions
“GN:SXXDB,” “GN:CAL,” or “GN:MAX” (GAIN)	3) Radar in vertical profile depiction. S = Sign (either “+” or “-,” but not both, may appear – use “+” for 0°); and XXDB represents the manual gain setting in decibels. “GN:CAL” represents the calibrated condition “GN:MAX” represents maximum manual gain Weather radar manual gain annunciation only appears when all following weather radar mode conditions are true: 1) Mode annunciation not overlaid with a red “X”; 2) Mode not standby or forced standby; and 3) Mode is ground map.

WX 3.8. Fuel Totalizer/Waypoint Distance Functions

Displayed as specified in Section 3 Display Symbology.

WX 4. MFD Fault Display (FAULTS) Menu

Upon selecting the MFD faults menu, the status of the following system parameters are displayed if weather radar is enabled:

- 1) Indicates weather radar power/communication status (WXR PWR X or WXR PWR OK). Status failed (WXR PWR X) reflects any one of the following conditions is true:
 - a) Loss of weather radar communication.
 - b) Weather radar mode is OFF.

- 2) Indicates weather radar fault status (WXR FAULT –, WXR FAULT X, or WXR FAULT OK). Status failed (WXR FAULT –) indicates it is not possible to determine weather radar faults. Status failed (WXR FAULT X) reflects any of the following conditions is true:
 - a) A cooling fault condition exists.
 - b) An attitude or range fault condition exists.
 - c) A control fault condition exists.
 - d) A T/R fault condition exists.

- 3) If weather radar type is RDR-2000 or RDR-2100, indicates radar control panel status (WXR RCP X or WXR RCP OK). Status failed (WXR RCP X) indicates loss of communication.

WX 5. Managing RDR-2100 Weather Radar Menus (PFD) (Step-By-Step)

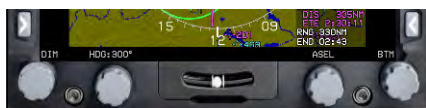

- 1) On PFD, push **1** and rotate to **WX-RDR** and push to enter.

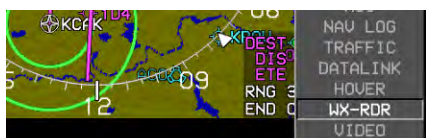

- 2) Press **MENU (R1)** and then **WX RDR (R7)**.

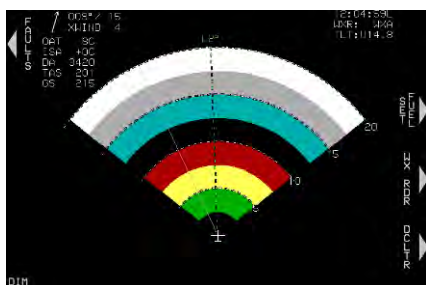

- 3) Press **OFF (R6)** to enable OFF mode. (This option is not shown when in OFF mode.)
- 4) Press **STBY (R7)** to enable standby mode. (This option not shown when in standby mode.)
- 5) Press **TEST (R8)** to enable test mode. (This option not shown when in test mode.)

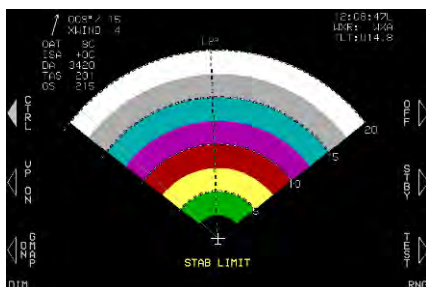



6) While in STBY mode, press **ON WX (L8)** to return radar to ON mode.

7) Current mode status is displayed in upper right corner of radar display.

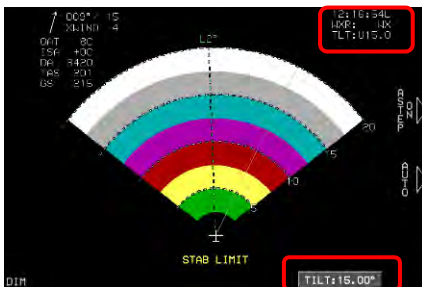
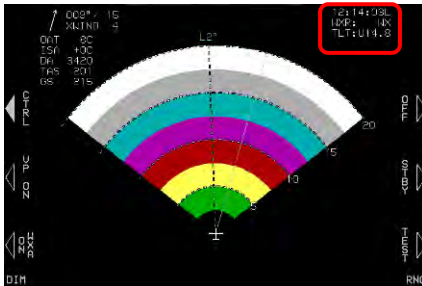

8) Press **VP ON (L7)** to toggle between horizontal and vertical modes.

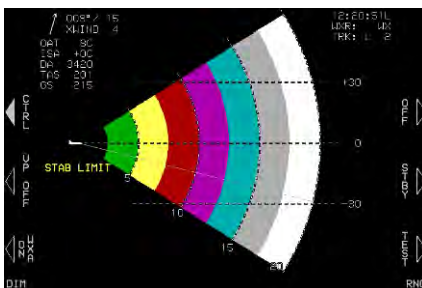

9) Press **VP OFF (L7)** to toggle back to horizontal profile.



10) Press **ON WXA (L8)** to enable Weather-Alert sub-mode in either VP ON or OFF modes

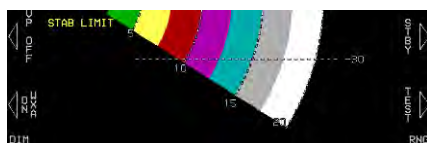

11) Weather-Alert sub-mode annunciated in upper right corner.



12) Press **ON GMAP (L8)** to enable Ground Map sub-mode in either VP ON or OFF modes. Ground Map sub-mode annunciated in upper right corner.

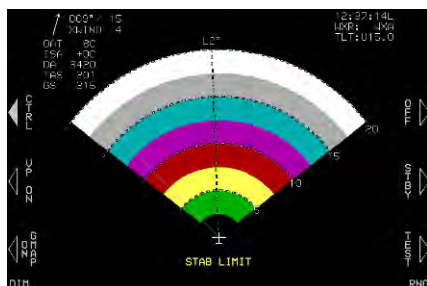

13) Press **ON WX (L8)** to resume normal weather radar mode of operation.

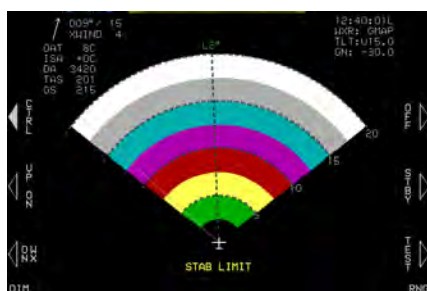

14) Radar mode of operation annunciated in upper right corner.



15) Rotate **1** to alter range of weather radar from 5.00 NM to 320.00 NM. Rotation direction dependent upon EFIS limits setting.

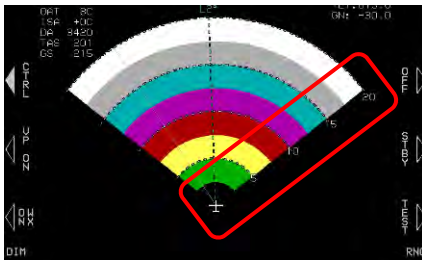

- 16) Range rings are located on the right side of the arc.
- 17) Press **CTRL (L6)** to enter radar control menu. (Not shown when in OFF or STBY mode.)

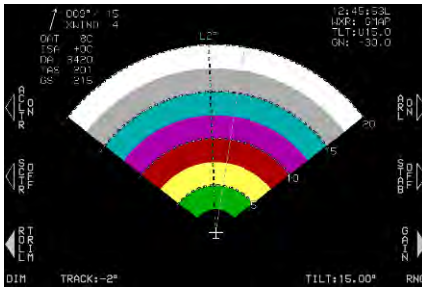

- 18) Press **ACLTR ON (L6)** to toggle anti-clutter option ON and OFF.
- 19) Press **SCTR ON (L7)** to toggle Sector Scan option ON and OFF.
- 20) Press **ROLL TRIM (L8)** and then rotate **1** to desired roll trim angle (increments of 0.125°) and push to enter.

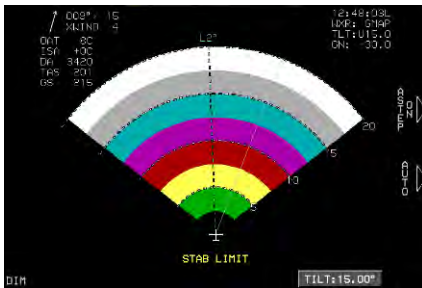

- 21) Push or rotate **2** to open menu for toggling **ASTEP ON** or OFF.
- 22) Press **ASTEP ON (R6)** to toggle ON and OFF.

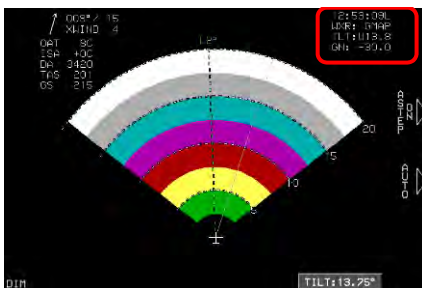

- 23) Push or rotate **2** to open tilt menu and then press **MAN (R7)** or **AUTO (R7)** to toggle between sub-modes.
- 24) Rotate **2** to set tilt angle between $\pm 15^\circ$. Set angle is annunciated above **2** and in upper right corner.
- 25) When in TILT AUTO mode, annunciation is above **2** and in upper right corner.

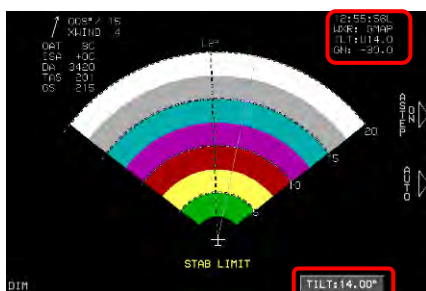

- 26) Press **ASTEP ON (R6)** or **ASTEP OFF (R6)** to toggle antenna tilt to sequentially step in 4° increments. (Auto step scan is entered initially by adjusting the tilt to +15° or -15°.)

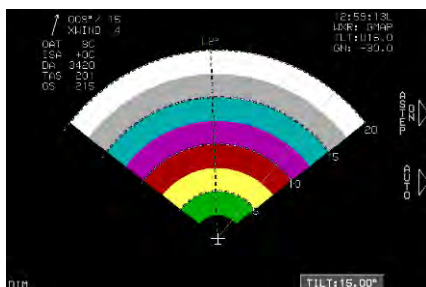

- 27) Press **BACK (L1)** or **EXIT (R1)** to exit out of TILT sub-mode.

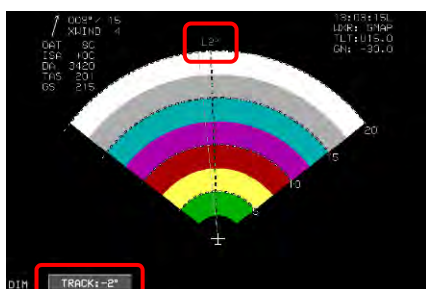

- 28) Push or rotate **3** and rotate or begin by rotating to set new track angle in 1° increments between limits set in EFIS limits. Read new track in two places.



- 29) Press **GAIN (R8)** to open gain menu and rotate **1** to change gain in 1 dB increments. Push to set selected gain value.

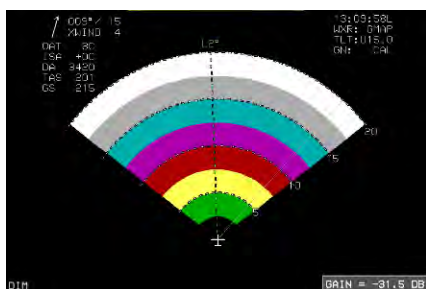

WX 6. Managing RDR-2100 Weather Radar Menus (MFD) (Top Area) (Step-By-Step)

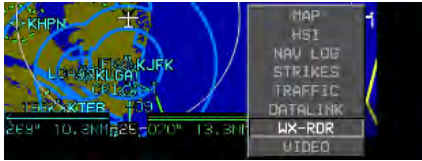

- 1) MFD with WX RDR in top area. Push **2** and rotate to **WX-RDR** and push to enter.

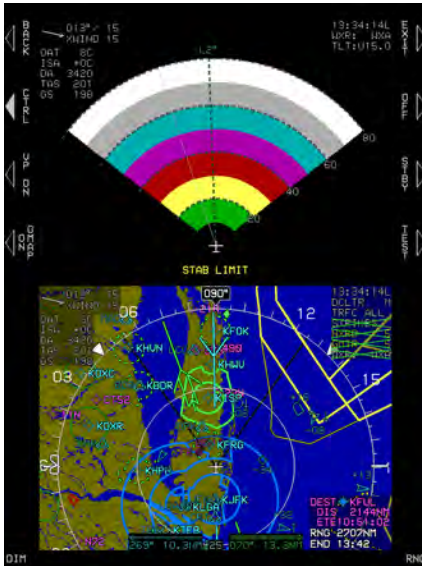

- 2) WX RDR appears in top area. Press **MENU (R1)** to open menus.

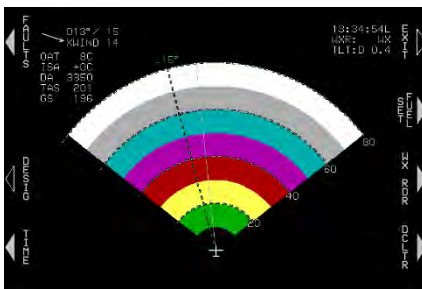

- 3) Press **WX RDR (R3)** within 10 seconds to open WX RDR menus for top area.

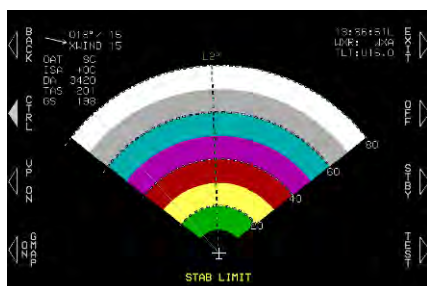

4) Press **CTRL (L2)** to open WX RDR menus. (Not shown when in OFF or STBY mode.)

5) Press **ACLTR ON (L2)** to toggle anti-clutter option between ON and OFF.

6) Press **SCTR ON (L3)** to toggle Sector Scan option between ON and OFF.



7) Press **ROLL TRIM (L4)** and then rotate to **1** desired roll trim angle (increments of 0.125°) and push to enter.

8) It is a design feature to retain most of the WX RDR menus in the top area with this configuration of the WX radar.



9) Press **ARL (R2)** to toggle automatic range limit option between ON and OFF.

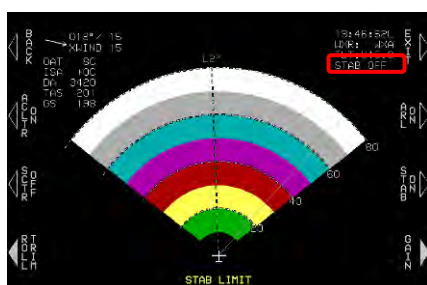

10) Press **STAB ON (R3)** to toggle Stabilization mode ON or **STAB OFF (R3)** to toggle OFF.



11) Push **2** or rotate to open **TILT** menu and then press **MAN (R7)** or **AUTO (R7)** to toggle between sub-modes.



- 12) Rotate **2** to set tilt angle between $\pm 15^\circ$. Set angle is announced above **2** and in the upper right corner.

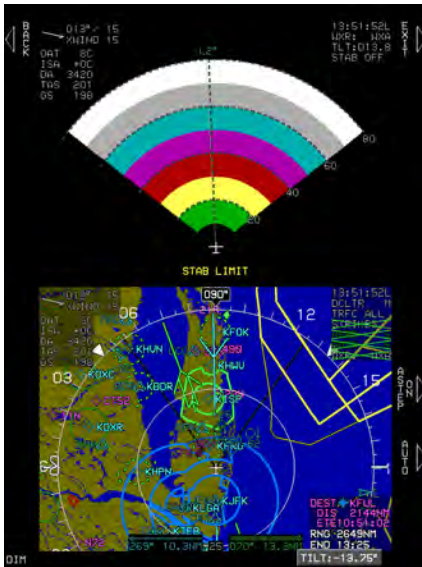

- 13) Tilt mode in MANUAL and tilt angle set to -13.75° and announced in full IDU image.

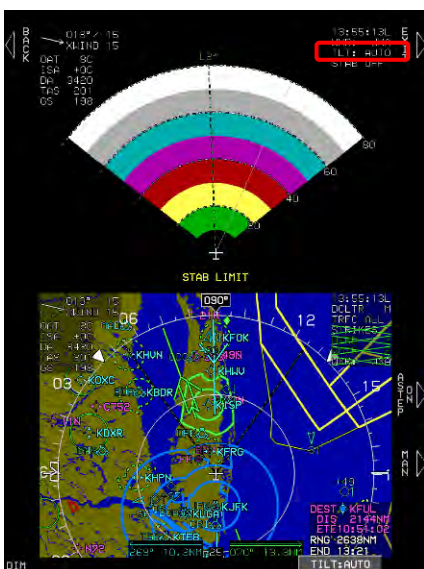

- 14) When in TILT AUTO mode, annunciation is above and in upper right corner of the top area.

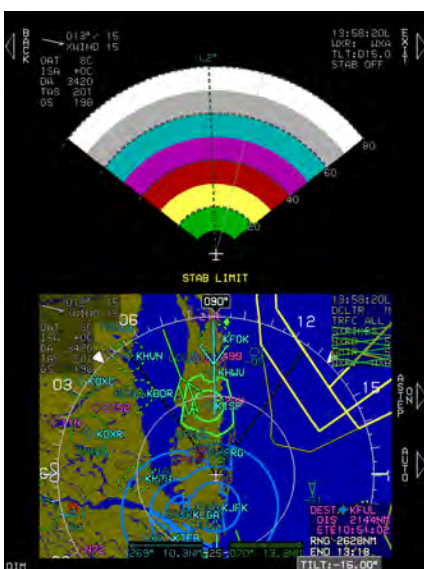

- 15) Press **ASTEP ON (R6)** or **ASTEP OFF (R6)** to toggle antenna tilt to sequentially step in 4° increments. (Auto step scan is entered initially by adjusting the tilt to +15° or -15°.)

- 16) Press **BACK (L1)** or **EXIT (R1)** to exit out of TILT sub-mode.

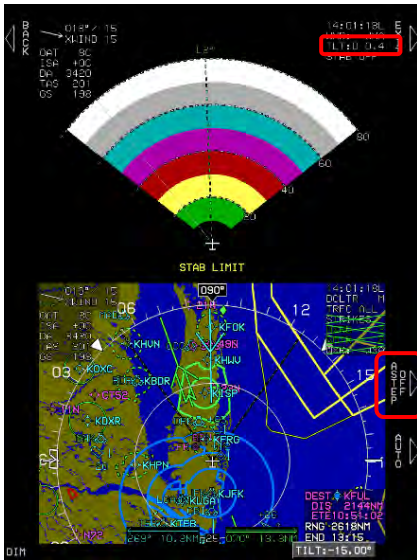

17) With ASTEP ON, the tilt angle increments change to 0.4°.

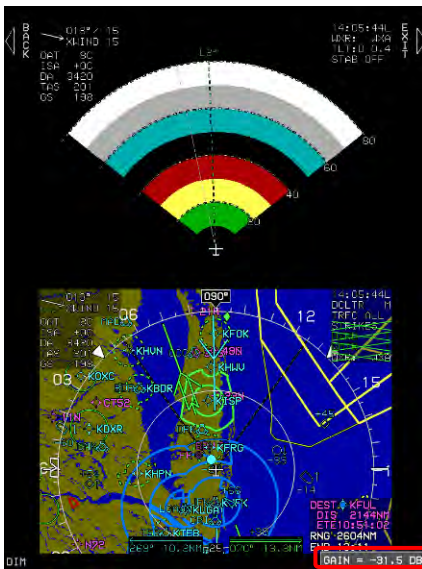

18) Press **GAIN (R4)** to open gain menu and make adjustments with **1**.

19) Rotate **1** to change gain in 1 dB increments. Push to set selected gain value.

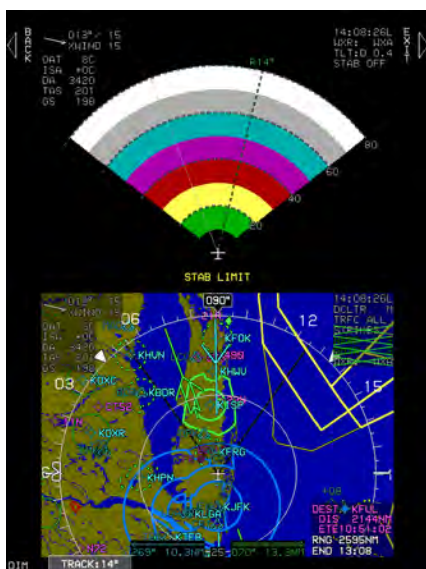

- 20) Push **3** and rotate or begin by rotating to set new TRACK angle in 1° increments between limits set in EFIS limits. Read new TRACK in two places.

WX 7. Managing RDR-2100 Weather Radar Menus (MFD) (BTM area) (Step-By-Step)

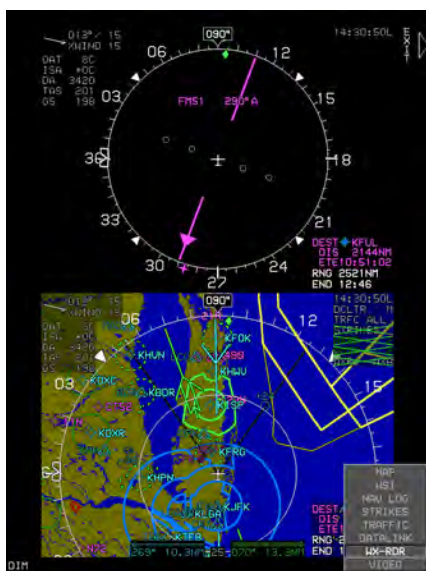

- 1) Push **1** and rotate to **WX-RDR** and push to enter. Press **MENU (R1)** and then **WX RDR (R7)** within 10 seconds to open WX RDR options.

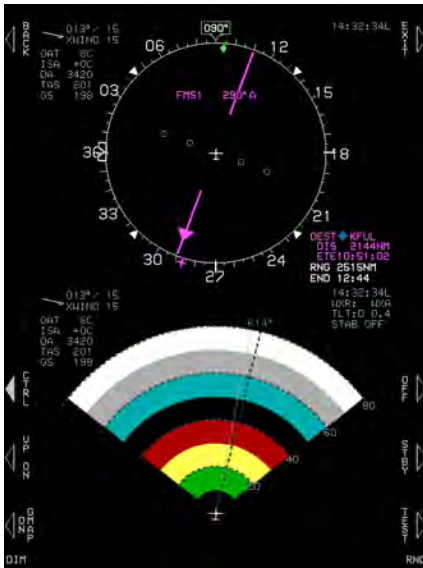

- 2) Press **OFF (R6)** to enable OFF mode.
- 3) Press **STBY (R7)** to enable standby mode. (This option not shown when in standby mode.)
- 4) Press **TEST (R8)** to enable TEST mode. (This option not shown when in TEST mode.)
- 5) Press **ON GMAP (L8)** to enable Ground Map sub-mode.
- 6) Press **VP ON (L7)** to toggle between horizontal and vertical modes.
- 7) Press **CTRL (L6)** to open WX RDR menus. (Not shown when in OFF or STBY mode.)
- 8) Rotate **1** to alter range of weather radar from 5.00NM to 320NM. Rotation direction dependent upon EFIS limits setting. Range rings are on the right side of the arc.
- 9) Press **STBY (R7)** to enable standby mode. (This option not shown when in standby mode.)
- 10) Press **ARL ON (R2)** to toggle automatic range limit option between ON and OFF.

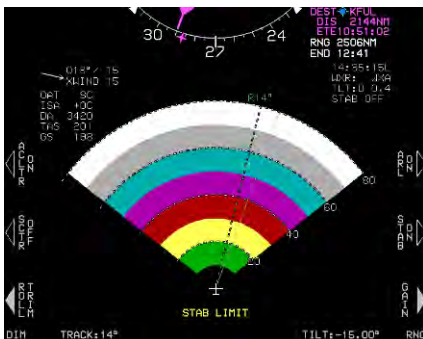



- 11) Push **2** and rotate or rotate to open TILT menu and then press **MAN (R7)** to place enter TILT mode. This action toggles off AUTO sub-mode.



- 12) Push **2** and rotate or rotate TILT angle between $\pm 15^\circ$. Set angle is annunciated above **2** and in upper right corner.



- 13) Press **ASTEP ON (R6)** or **ASTEP OFF (R6)** to toggle antenna tilt to sequentially step in 0.4° increments. (Auto step scan is entered initially by adjusting the tilt to $+15^\circ$ or -15° .)

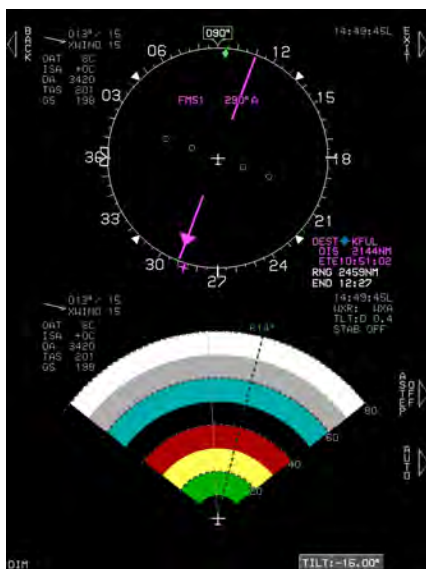

- 14) Press **BACK (L1)** or **EXIT (R1)** to exit out of TILT sub-mode.

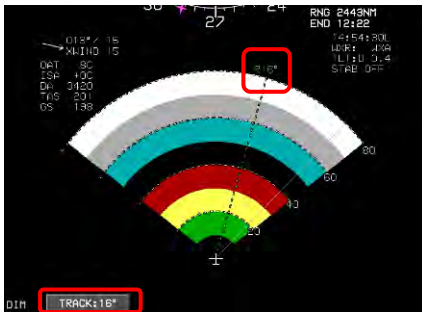

- 15) Push and or rotate **3** or begin by rotating to set new TRACK angle in 1° increments between limits set in EFIS limits. Read new TRACK in two places. Push **3** to enter or press **BACK (L1)** to exit from TRACK sub-mode.

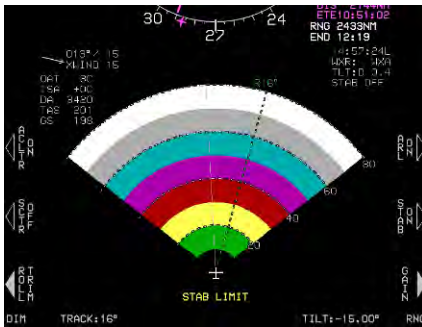

- 16) Press **ROLL TRIM (L8)** to enter ROLL TRIM sub-mode.



- 17) Press **ROLL TRIM (L8)**, rotate **1** to desired roll trim angle (increments of 0.125°), and then push to enter or press **BACK (L1)** or **EXIT (R1)** to exit menu.

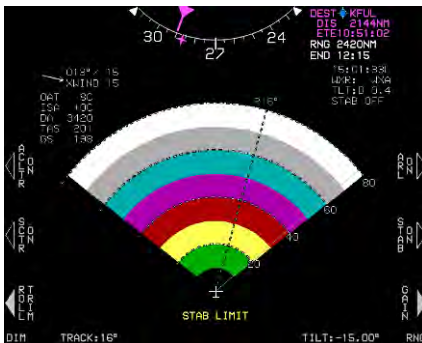

- 18) Press **SCTR ON (L7)** to toggle Sector Scan option between ON and OFF.
- 19) Press **ACLTR ON (L6)** to toggle anti-clutter option between ON and OFF.
- 20) Push **3** and rotate or begin by rotating to set new TRACK angle in 1° increments between limits set in EFIS limits. Read new TRACK in two places.



- 21) Push **3** to enter and clear TRACK sub-menu or press **BACK (L1)** or **EXIT (R1)** to exit menu.



- 22) Press **MENU (R1)** and then **DCLTR (R8)**. Rotate **1** to **ROUTE** and push to toggle ON or OFF and rotate to **DONE** and push to enter or press **EXIT (R1)** to exit DCLTR sub-menu.

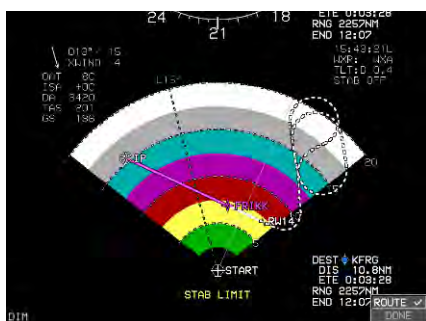
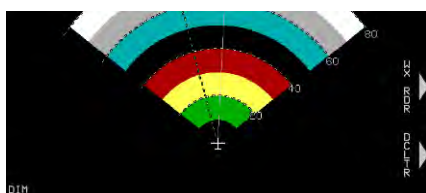

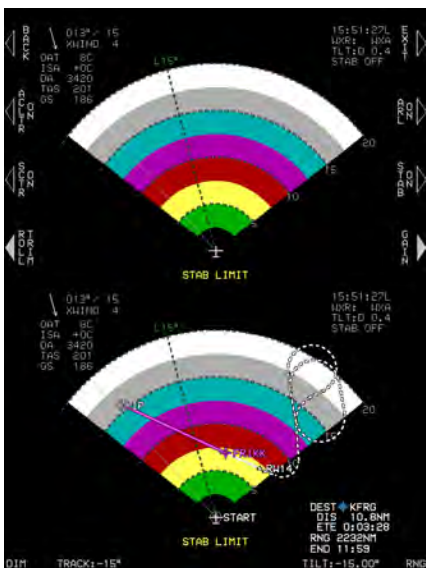

- 26) WX-RDR mode control and selection menu is open for the top area.
- 27) Bottom area is still showing an uncontrolled WX-RDR display until the top area menu is exited by pressing **EXIT (R1)** as shown below.

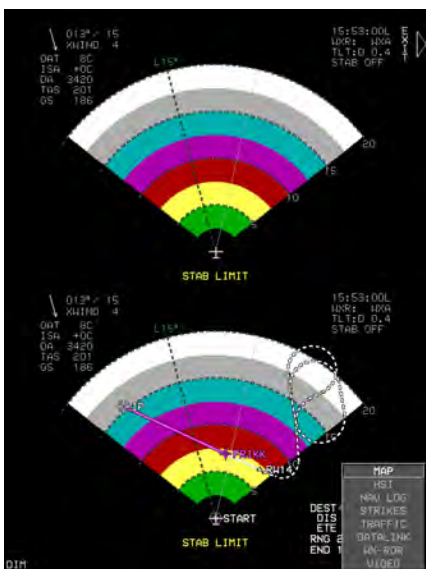

- 28) Now the bottom area can be changed to one of the other remaining page options.



WX 8. Managing RDR-2000 Weather Radar Menus (PFD) (Step-By-Step)



- 1) Push **1** and rotate to WX-RDR and push to enter.



- 2) Weather Radar appears on the PFD bottom area.
- 3) Press **MENU (R1)**.



- 4) Press **WX RDR (R7)** within 10 seconds.



- 5) Press **OFF (R6)** to turn off WX-2000.

- 6) Press **STBY (R7)** to toggle WX RDR to STBY mode, press **ON WX (L8)** to turn on RDR-2000.

- 7) Press **TEST (R8)** to enable TEST mode. (This option not shown when in test mode.)

- 8) Press **ON GMAP (L8)** to enable Ground Map sub-mode.

- 9) Press **VP ON (L7)** to toggle between horizontal and vertical modes.

- 10) Press **CTRL (L6)** to open WX RDR menus. (Not shown when in OFF or STBY mode.)



- 11) Press **STAB (R7)** to toggle Stabilization sub-mode ON and OFF (R6). Annunciation is found in upper right corner.

- 12) Press **GAIN (R8)** to open GAIN menu and making adjustments with **1**.



- 13) Press **ROLL TRIM (L8)** and then rotate to **1** desired roll trim angle (increments of 0.125°) and push to enter or press **BACK (L1)** or **EXIT (R1)** to exit menu.

- 14) Press **ACLTR ON (L6)** to toggle anti-clutter option between ON and OFF.

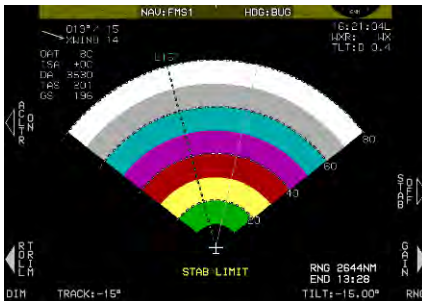

- 15) Push **3** to enter and clear TRACK sub-menu or press **BACK (L1)** or **EXIT (R1)** to exit menu.



- 16) Press **ROLL TRIM (L8)** and then rotate to **1** desired roll trim angle (increments of 0.125°) and push to enter or press **BACK (L1)** or **EXIT (R1)** to exit menu.
- 17) Push **2** and rotate or rotate to open TILT menu. Rotate to desired tilt angle between ±15°. Set angle is annunciated above **2** and in upper right corner with "D" for down ° and "U" values. for up push to enter or press **BACK (L1)** or **EXIT (R1)** to exit menu.
- 18) Push to enter or press **BACK (L1)** or **EXIT (R1)** to exit menu.

WX 9. Managing RDR-2000 Weather Radar Menus (MFD) (Step-By-Step)

The MFD weather radar menu for the RDR-2000 MFD is the same as for the RDR-2100 with the exception of fewer menu options as described above for the RDR-2000 PFD.

WX 10. Menu Synchronization

See Section 5 Menu Functions and Step-By-Step Procedures for more information.

Table WX-5: Menu Synchronization

Menu Parameter	Notes
<p><i>The following menu parameters are synchronized across all displays when crosslink is enabled. Otherwise, they are only synchronized onside. These parameters are FMS parameters and allow the pilot and co-pilot FMSs to be operated independently when crosslink is inhibited.</i></p>	
WX RDR Control Menu parameters	Used to synchronize certain RDR-2XXX modes. See note below.
<p><i>The following menu parameters are only synchronized onside. These parameters are usually sensor selections or PFD options used to keep the appearance of any pilot's PFD consistent in the case of PFD reversion. The onside characteristic means that individual pilots can still adjust their PFD settings to their preference.</i></p>	
WX RDR Control Menu parameters	Synchronized onside when Honeywell RDR-2XXX is installed.
Rate of Turn Indication flag	Onside due to range being controlled by the weather radar.
Weather Radar Scale	Onside because range is controlled by the weather radar.
<p><i>The following menu parameters are independent between displays. These are used to support non-PFD display options to give the pilot maximum MFD operating flexibility. Note that some of these parameters are also independent between top and bottom 680 MFD areas as specified in the notes.</i></p>	

Table WX-5: Menu Synchronization

Menu Parameter	Notes
MFD Selected Page	This parameter is transmitted to all other IDUs to support weather radar vertical profile mode selection.
MFD Map Page Settings	Map scale is transmitted onside to support weather radar range selection.

NOTE:

When using EFIS menu system for RDR-2XXX control, the weather radar mode received from the offside system is used to update onside weather radar mode as follows. This is to ensure weather radar power on/off is synchronized between both sides.

When offside mode is commanded to STBY, TEST, or ON and if onside mode is OFF, then the onside mode is set to STBY.

When offside mode is commanded to OFF, then the onside mode is also set to OFF.

Video

V 1. Video Input Page

PAGE Menu (❶): **VIDEO** – opens Video Input page

The video input page is an image of 640 by 480 pixels and accepts video input signals in the RS-170 composite format. The system is configurable to the NTSC, PAL (including the PAL-m and PAL-nc variants), or SECAM versions of RS-170 separately for each video input. In addition, an auto-detection mode, which programs the video input chip to process most standard RS-170 formats, is configurable for each video input.

When no video signal is detected, the video input page is black and **NO VIDEO IMAGE AVAILABLE** is displayed in white on the center of the page. To aid in diagnosing problems with undetected video signals, the following annunciations are also displayed:

- 1) **NO INTERLACED SIGNAL**: No interlaced signal detected.
- 2) **NO HORIZ OR VERT SYNC**: No horizontal or vertical synchronization detected.
- 3) **NO COLOR SIGNAL**: No video chroma signal detected.
- 4) **LOAD ERROR DETECTED**: Video chip reports a load error.
- 5) **TRIGGER ERROR DETECTED**: Video chip reports a trigger error.
- 6) **PROGRAMMING ERROR DETECTED**: Video chip reports a programming error.

V 1.1. PFD Page First-Level Option Descriptions

- 1) **CTRST (❸)**: Adjusts the contrast setting for the current video input.
- 2) **BRT (❷)**: Adjusts the brightness setting for the current video input.



Figure V-1: First Page PFD Video Control

V 1.2. Top-Level Menu Option Descriptions

- 1) **1** Encoder: On a PFD or MFD operating in Normal mode, if the bottom area is showing a video page, rotating the encoder changes the zoom level (clockwise = increase, counterclockwise = decrease).
- 2) **2** Encoder: On an MFD (IDUs other than #1) operating in Normal mode, if the top area is showing a video page, rotating the encoder changes the zoom level (clockwise = increase, counterclockwise = decrease).

V 1.3. MFD Page First-Level Option Descriptions

- 1) **CTRST (3)**: Adjusts the contrast setting for the current video input.
- 2) **BRT (2)**: Adjusts the brightness setting for the current video input.
- 3) **FORMAT.. (R8)**: Activates the appropriate page format menu option.

Table V-1: Video Input Controls

Controls Settings	Definition	Notes
BRT	Adjust brightness setting	DFLT (R4) resets to nominal default (50%) value.
CTRST	Adjust contrast setting	
SAT	Adjust chroma saturation (color intensity) setting	
HUE	Adjust chroma hue (red-green balance) settings	
SOURCE	Select optional video source	Displays selected video input, only if more than one video input is enabled.
DCLTR	Activate option list to select video input status	Video input status settings as in § V 2.



Figure V-2: Encoder Functions for MFD Video Page

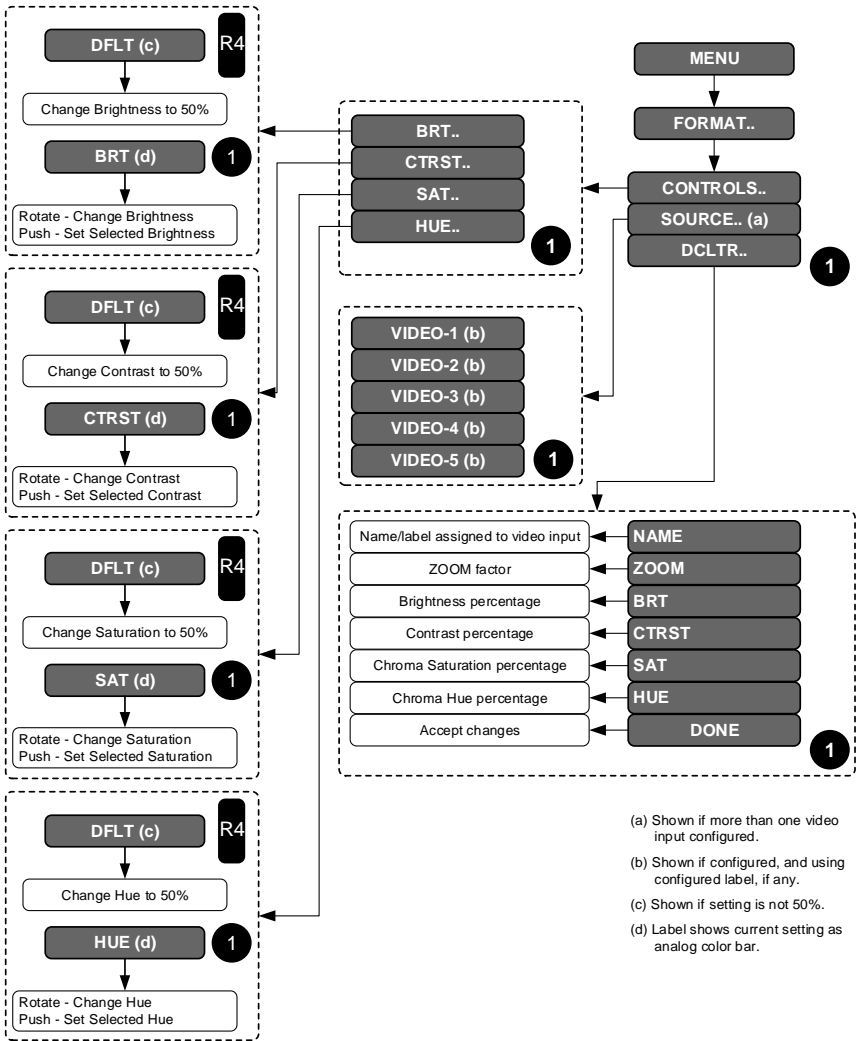
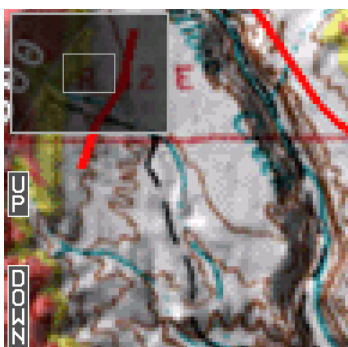

Figure V-3: MFD Video Input Format Menu

V 1.4. Pan Mode



When the ZOOM level is greater than 1, the Video page has a pan mode for selecting the portion of the video image displayed by replicating pixels. When pan mode is active, controls are present to allow moving the portion displayed up, down, left, and right.

Figure V-4: Video Pan View

A mini-map of the displayed image's position in the full video image is displayed for 10 seconds after:

- 1) Entering pan mode;
- 2) Changing the zoom level to a value greater than 1;
- 3) Panning the zoomed image.

Exiting pan mode removes pan mode controls and mini-map, if any.

Table V-2: Top-Level Auto Pop-Up Function Descriptions With Pan Mode Enabled			
Top Area	Bottom Area	Tile Legend	Action
L2	L6	UP	Press to move the section of video image displayed in specified direction.
L3	L7	DOWN	
R2	R6	LEFT	
R3	R7	RIGHT	

V 2. Video Input Status Display

When selected, the following are optionally displayed in the upper right corner of the Video Input page:

- 1) **Label:** Identifies video input source and is configurable to one of a set of predefined labels. If no label is configured, the label is **VIDEO-n** where **n** is the video input source number.
- 2) **ZOOM:** Amount of pixel expansion is displayed as **ZOOM nnX** where **nn** is the ZOOM level.

- 3) **Brightness:** Displayed as **BRT nnn%** where **nnn** is the brightness setting as a percentage of the maximum value.
- 4) **Contrast:** Displayed as **CTRST nnn%** where **nnn** is the contrast setting as a percentage of the maximum value.
- 5) **Saturation:** Chroma saturation is displayed as **SAT nnn%** where **nnn** is the saturation setting as a percentage of the maximum value.
- 6) **Hue:** Chroma hue is displayed as **HUE nnn%** where **nnn** is the hue setting as a percentage of the maximum value.

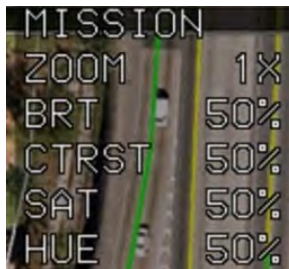



Figure V-5: Video Status

V 3. Menu Synchronization

Table V-3: Menu Synchronization

Menu Parameter	Notes
<p><i>The following menu parameters are independent between displays. These are used to support non-PFD display options to give the pilot maximum MFD operating flexibility. Note that some of these parameters are also independent between top and bottom 680 MFD areas as specified in the notes.</i></p>	
 	
<p>MFD Video Page Settings</p>	<p>Independent between top and bottom MFD areas with exception of the following hardware settings:</p> <ul style="list-style-type: none"> • Selected Input • Brightness • Contrast • Saturation • Hue

Round Dials

RD 1. PFD Primary Flight Instrumentation

This following details round dial display symbology used on the PFD and MFD IDU-680 in normal and essential modes. The round dials option is only available with pure digital ADC configured. Not all combinations of possible views are represented. See Section 3 Display Symbology for further information on the following display symbology.

RD 1.1. Pitch Scale



Figure RD-1: Pitch Scale

The white pitch scale and horizon rotates about the large aircraft symbol reference marks according to the aircraft's roll angle. The pitch scale has 5° with major increments and pitch scale labels every 10°. Pointer bars at the ends of each major increment indicate the direction to the horizon. Pitch scale increments automatically declutter to present the fewest possible increments needed.

RD 1.2. Flight Director Symbology

A pilot-selectable flight director is available through the menu system or integrated autopilot/flight director avionics. When selected, one of the above symbology examples appear when valid steering commands are received.



FD-1 Single Cue



FD-2 Dual Cue

Figure RD-2: Flight Director

RD 1.3. Marker Beacon Indicators

When enabled and valid marker beacon indicators with appropriate coloring and markings are displayed in the lower central portion of the PFD. During a built-in-test, more than one marker beacon can be active. Marker beacons acquired from NAV VLOC1 or VLOC2. Marker beacons are disabled when the NAV source is FMS.



Outer Marker



Middle Marker

Figure RD-3: Marker Beacon Indicators

RD 1.4. Unusual Attitude Mode

Unusual attitude mode is enabled when the pitch attitude exceeds +30° or -30° or bank angle exceeds 65° left or right. Once enabled, unusual attitude mode remains engaged until pitch attitude returns to within 5° of the horizon and bank attitude returns to within 10° of the horizon.



Pitch up 25° Recovery Chevrons Only

Pitch up 31° Unusual Attitude Mode

Figure RD-4: Unusual Attitude Mode

RD 1.5. Bank Angle Scale

The bank angle scale and roll pointer are centered upon the waterline. During EFIS limits configuration, either a roll pointer or sky pointer can be selected.



Roll Pointer

Sky Pointer

Figure RD-5: Bank Angle Scale Types

RD 1.6. Pitch Limit Indicator

When enabled in either category of airplane, a yellow pitch limit indicator appears at 20 KIAS above stall speed. Stall speed is defined as the following:

- 1) Part 23 airplanes, the higher of the aircraft's 1-G V_{S1} or V_{S1} corrected for G-loading; or
- 2) Part 25 airplanes, if pilot-input V_{REF} is valid, the higher of the aircraft's 1-G V_{SO} or V_{SO} corrected for G-loading where V_{SO} is calculated by dividing the pilot-input V_{REF} by 1.23.



5 Knots before Stall



Stall Speed

Figure RD-6: Pitch Limit Indicator

The pitch limit indicator merges with the large aircraft reference symbol at stall speed and continues moving downward as indicated airspeed further decreases.

RD 1.7. AGL Indication



Figure RD-7: AGL Indicator

AGL altitude is displayed as shown above at the bottom of the display or above the CDI. The source for AGL indication is the source being used for the TAWS, which is designated as follows:

R = Radar Altitude

G = GPS/SBAS geodetic height less database found elevation.

B = Barometric altitude less database ground elevation.

AGL altitude is not displayed when it is greater than the radar altimeter maximum valid altitude as set in the EFIS limits and is not displayed when it is invalid. This area also includes a decision height set with the PFD bugs menu.

Table RD-1: AGL Altitude Values

Value	Resolution	Color
<300'	10'	White
<100' >300'	5'	
>100'	1'	
Decision Height	10'	 White but turns amber (yellow) and flashes at and below DH.

RD 1.8. Landing Gear Indication

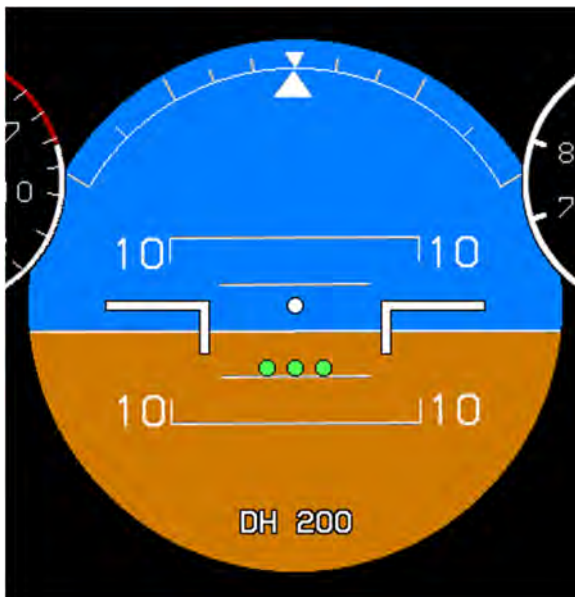

Figure RD-8: Landing Gear Indication

When configured as retractable gear in the EFIS limits, the landing gear is shown as three small green “tires” below the large aircraft reference marks. This symbology is driven by discrete inputs.

RD 1.9. Airspeed Display

The airspeed display digitally displays indicated airspeed in knots, miles per hour, or kilometers per hour as set in the EFIS limits. The display is scaled to show the entire operating range of the aircraft. CW movement corresponds to increasing speed. When an ADC sensor fails, the display appears as shown in Figure RD-18.

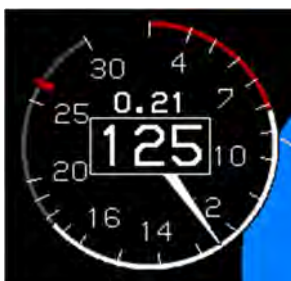

Figure RD-9: Airspeed Display



Without Airspeed Bugs



IAS Bug Set to 170 and Indicating 170 KIAS



IAS Bug Set to 170 and Indicating 150 KIAS

Figure RD-10: Airspeed Display Limits and BUGs

Table RD-2: Airspeed BUGs

Airspeed Bug	Limits	Notes
	The higher of $1.2 \times V_S$ or 60KIAS at the low end, and red-line airspeed (V_{NE} , V_{MO} , or M_{MO})	** Can be used as a visual reference. Mutually exclusive with VSI bug.
** When integrated with Genesys/S-TEC DFCS or partially integrated through use of the vertical mode discrete input as a control parameter for climbs and descents. When vertically integrated with an autopilot, the airspeed bug is filled-white when in airspeed climb or descent mode. Otherwise, the airspeed bug is hollow-white. When not vertically integrated, the airspeed bug is filled-white at all times.		

RD 1.9.1 Airspeed Readout



When enabled the Mach indicator is displayed above the airspeed readout with a resolution of .01 Mach.

Figure RD-11: Airspeed Readout with Mach Number

If in air mode, a red low-speed awareness area from the bottom of the dial to V_{SO} .

If in ground mode, a gray area from the bottom of the dial to V_{SO} . The airspeed readout is gray but otherwise white in this area.

If a valid V_{FE} exists, a white flap-operating area from V_{SO} to V_{FE} . The airspeed is white in this area.

A gray safe-operating area from V_{FE} to V_{MO}/M_{MO} and the airspeed readout is green in this area.

For aircraft with V_{NE} :

- 1) A green safe-operating area from V_{S1} to V_{NO}/M_{NO} . The airspeed readout is green in this area.
- 2) A yellow caution area from V_{NO}/M_{NO} to V_{NE}/M_{MO} . The airspeed is yellow in this area.
- 3) A red radial line at V_{NE}/M_{MO} . The airspeed readout is red at or above the radial line.

For aircraft with V_{MO} :

- 1) A grey safe-operating area from V_{FE} (if existing) to V_{SO} to V_{MO}/M_{MO} . The airspeed is green in this area.
- 2) A red radial line at V_{MO}/M_{MO} . The airspeed readout is red at or above this radial line.

The airspeed dial for Part 23 airplanes have additional airspeed markings as follows:

- 1) For reciprocating multiengine-powered aircraft 6,000 pounds or less, a red radial line at V_{MC} .

- 2) For reciprocating multiengine-powered aircraft 6,000 pounds or less, a blue radial line at V_{YSE} .

The airspeed dial for part 25 airplanes have additional airspeed markings as follows:

- 1) If in air mode with a pilot-input V_{REF} value:
 - a) A red low-speed awareness area from the bottom of the dial to G-compensated $1.1 \times V_{SO}$. The airspeed readout is red in this area.
 - b) A yellow low-speed awareness area from G-compensated $1.1 \times V_{SO}$ to G-compensated $1.2 \times V_{SO}$. The airspeed is yellow in this area.
 - c) If a valid V_{FE} exists, a white flap-operating area from G-compensated $1.2 \times V_{SO}$ to V_{FE} and a gray normal-operating area from V_{FE} to the lower of V_{MO} or M_{MO} . The airspeed is white in the flap-operating area and green in the normal-operating area.
 - d) If a valid V_{FE} does not exist, a gray normal-operating area from G-compensated $1.2 \times V_{SO}$ to the lower of V_{MO} or M_{MO} . The airspeed readout is green in this area.
- 2) If in ground mode or without a pilot-input V_{REF} value.
 - a) If a valid V_{FE} exists, a white flap-operating area from the bottom of the dial to V_{FE} and a gray normal-operating area from V_{FE} to the lower of V_{MO} or M_{MO} . The airspeed readout is gray at 0 but otherwise white in the flap-operating area and green in the normal-operating area.
 - b) If a valid V_{FE} does not exist, a gray normal-operating area from the bottom of the dial to the lower of V_{MO} or M_{MO} . The airspeed readout is gray at 0 otherwise white below 60 and green at or above 60 in this area.
- 3) A red radial line at the lower of V_{MO} or M_{MO} . The airspeed readout is red at or above the red radial line.

RD 1.9.2 Takeoff and Landing Speed Bugs

In airplanes Part 23 or 25 airspeed scale, V_1 , V_R , V_2 , V_{ENR} , V_{REF} and V_{APP} can also be shown on the airspeed dial when set. The V_1 , V_R , and V_2 symbols automatically declutter when above 2000 feet AGL.

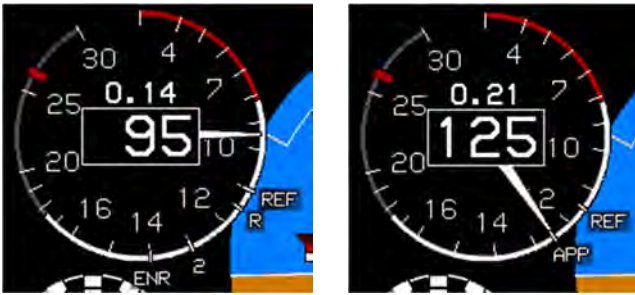

Figure RD-12: Takeoff and Landing Speed Bugs

RD 1.10. Altimeter



Figure RD-13: Altimeter Setting



The altimeter setting digitally displays the altimeter setting in either inches of mercury (inHg) or millibars (mbar) according to the pilot-selected units.

Figure RD-14: Altimeter QNH



The mode is annunciated as QFE operations; otherwise, no mode is annunciated

Figure RD-15: Altimeter QFE

QFE: Barometric setting resulting in the altimeter displaying height above a reference elevation (i.e., airport or runway threshold).

QNE: Standard barometric setting (29.92 inHg or 1013 mbar) used to display pressure altitude for flight above the transition altitude.

QNH: Barometric setting resulting in the altimeter displaying altitude above mean sea level at the reporting station.

RD 1.11. Altitude Display



The altitude readout digitally displays barometric altitude to the nearest ten feet as adjusted by an altimeter setting and shows a 1000-foot range with labels and graduations every 100 feet. Clockwise rotation of the pointer corresponds to increasing altitude. All graduations are removed when below sea level.

Figure RD-16: Altitude Display

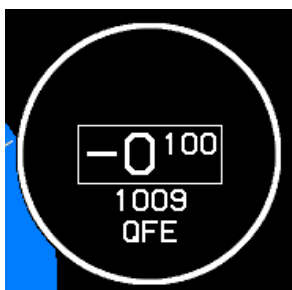

Figure RD-17: Altitude Display (When Below Sea Level)

RD 1.11.1 Loss of ADC Sensor Indication

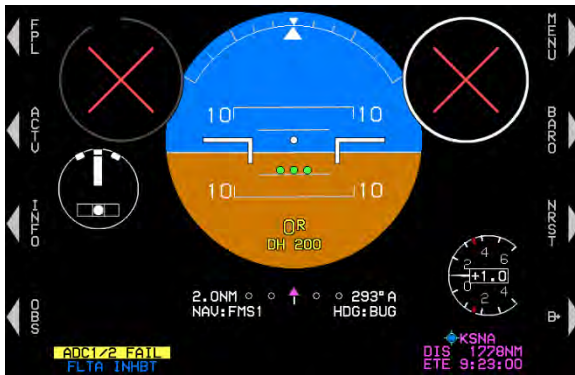

Figure RD-18: Airspeed and Altitude with Loss of ADC

RD 1.11.2 Altitude Sub-Mode



Altitude sub-mode user-selectable triangular target altitude bug shown here at 4,400'. The bug is limited to -1,000' up to 50,000' and is removed when more than 500' away from current altitude.

Figure RD-19: Target Altitude Bug

The target altitude bug can be used as a visual reference or when vertically integrated with the Genesys/S-Tec DFCS or partially integrated through use of the vertical mode discrete input, as a climb control parameter for climbs or descents, the bug characteristics indicate the following modes:

- 1) Filled-white when in altitude hold mode.
- 2) Hollow-white when in a climb or descent mode.
- 3) Filled-white during altitude hold capture.

When not vertically integrated with the Genesys/S-Tec DFCS, the target altitude bug is filled-white at all times.



When in VNAV sub-mode, the VNAV altitude bug appears when within 500' from the current altitude. In this example, the VNAV altitude is 5,100'.

Figure RD-20: VNAV Sub-Mode

The VNAV bug can be used as a visual reference or when vertically integrated with the Genesys/S-Tec DFCS or partially integrated through use of the vertical mode discrete input as a control parameter for climbs or descents. The following bug characteristics indicate the following modes:

- 1) Filled-magenta when in altitude hold mode.
- 2) Hollow-magenta when in a climb or descent mode.
- 3) Filled-magenta during altitude hold capture.

When not vertically integrated with the Genesys/S-Tec DFCS, the VNAV bug is filled-white at all times.

RD 1.11.3 Metric Altitude



Metric altitude values may be selected from within the declutter menu with a resolution of 1 meter.

Figure RD-21: Metric Altitude

RD 1.12. Vertical Speed Indicator

The VSI located below the altitude display with a readout and dial pointer and scale of $\pm 6,000$ feet per minute. The integral scale graduations are ± 500 , $\pm 1,000$, $\pm 3,000$ and $\pm 6,000$ feet per minute for airplanes with VMO or airspeed scale type FAR part 25, or in applications where TCAS-II is enabled. Otherwise, the scale will be $\pm 3,000$ with graduations of ± 500 , $\pm 1,000$, $\pm 3,000$. CW (upward) rotation of the pointer corresponds to increasing vertical speed while CCW corresponds to decreasing speed digitally displaying vertical speed rounded to the nearest 100 feet per minute.



Figure RD-22: Vertical Speed Indicator



When TCAS-II is enabled, the background of the VSI functions as an RA display with green and red colored regions to provide RA maneuver guidance.

Figure RD-23: Vertical Speed Indicator RA Display

Table RD-3: Scale Graduations and Display

Type Traffic Installed	Scale Limit	Scale Graduations and Display
With TCAS-II	$\pm 6,000$ fpm	$\pm 500, \pm 1,000, \pm 2,000, \pm 4,000,$ and $\pm 6,000$ fpm Background of the VSI functions as an RA display with green and red regions to provide RA maneuver guidance.
Without TCAS-II	$\pm 3,000$ fpm	$\pm 500, \pm 1,000, \pm 2,000,$ and $\pm 3,000$ fpm

The vertical speed bug is mutually exclusive with the IAS bug and can be used either as a visual reference or when vertically integrated with the Genesys S-TEC DFCS or partially integrated through use of the vertical mode discrete input as a control parameter for climbs or descents. When vertically integrated, the vertical speed bug is filled-white when in VSI climb or descent mode. Otherwise, the vertical speed bug is hollow-white as shown above on the left. When not vertically integrated with an autopilot, the vertical bug is filled-white at all times.



VSI bug set to +1,000 fpm with Genesys/S-TEC DFCS enabled

VSI bug set to +1,000 fpm without Genesys/S-TEC DFCS enabled

Figure RD-24: VSI Bugs

RD 1.13. Heading Display

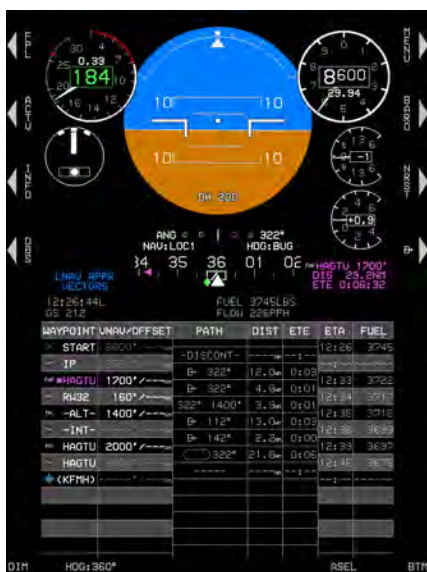
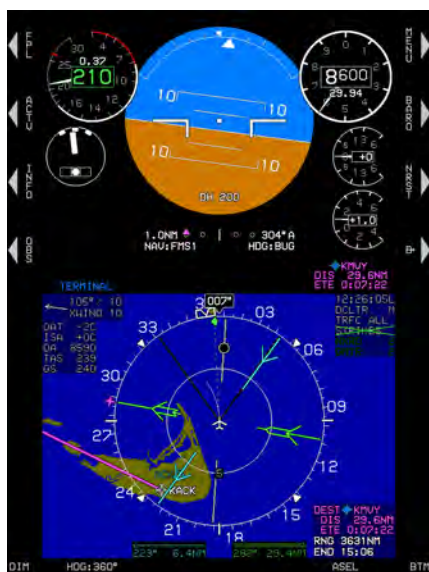

Figure RD-25: Heading Display

The heading display appears in a blacked-out area on the bottom to emulate a “Basic-T”. The heading display automatically declutters when a compass rose is shown in the bottom area.



When AHRS is in DG mode, heading indicator appears.

Figure RD-26: Heading Indicator when AHRS in DG Mode

RD 1.14. Heading Failure Mode

In addition, the equipment has a heading failure mode. With heading failed, the PFD heading scale and MFD compass rose align with track (if available) or are removed and replaced with a red-X.

In this failure mode, the PFD heading scale includes “GPS TRK” around the track marker to clearly delineate the failure mode.



Figure RD-27: GPS TRK



Figure RD-28: Heading Indicator with Heading Failure and Good GPS



Figure RD-29: Heading Indicator with Heading Failure with GPS Failure

RD 1.15. G-Force Indicator



The G-Force indicator located below the VSI has a readout dial and pointer. The scale accommodates any G-Force limits with a minimum of +6/-4G. The dial is centered on 1G including labeled indices at even values and displays G-Force to the nearest tenth G. Clockwise (upward) rotation of the pointer corresponds to increasing G-Force while counter clockwise rotation corresponds to decreasing G-Force. The pointer and readout are normally white but turn yellow when G-force equal or exceeds a G-limit.

Figure RD-30: G-Force Indicator

The G-Force indicator includes positive and negative G telltales. The positive G telltale appears whenever positive G-Force exceeds 2.5G. The negative G telltale appears whenever negative G-force is less than 0G. Either G telltale is resettable by the pilot so long as the associated G limit has not been exceeded. If a G limit has been exceeded, the associated telltale can only be cleared by maintenance action. The G telltales automatically reset upon software initialization as long as the associated G limit has not been exceeded.

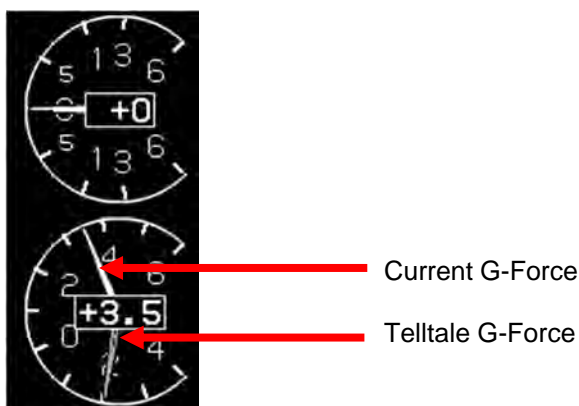

Figure RD-31: G-Force Telltale Indication

RD 1.16. Turn Rate Indicator



The turn rate indicator is displayed below the airspeed display. This standard “turn needle” displays marks representing a standard rate turn. The full scale for the turn needle is beyond the standard rate turn mark. This allows the pilot to fly a standard rate turn. The “balance ball” is driven from accelerometers within the AHRS.

Figure RD-32: Turn Rate Indicator

RD 1.17. Timer Indication

A countdown or count-up timer can be displayed above the large aircraft reference marks when selected through the menu as described in Section 3 Display Symbology.



Figure RD-33: Timer Indication

RD 1.18. Vertical Deviation Indicator (VDI)

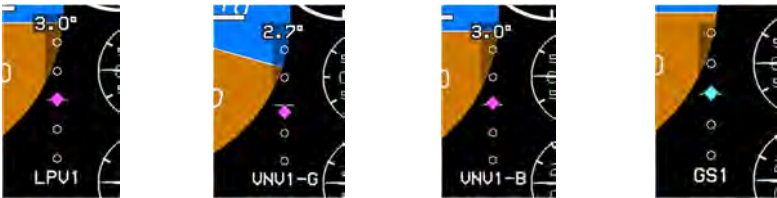

Figure RD-34: Vertical Deviation Indicator (VDI)

The vertical deviation indicator (VDI) on the right side displays vertical deviation for the selected vertical navigation source for displaying descent profile but disappears in unusual attitude mode.

- 1) **LPV Mode and LPV1 or LPV2:** When descending on final approach segment in LPV mode. GPS altitude used to generate VDI; pilot may follow guidance to LPV minima regardless of temperature.
- 2) **LNAV Mode and VNAV1-G or VNAV2-G:** When descending on final approach segment in LP, LNAV/VNAV, and LNAV or RNP modes when using GPS VNAV. GPS altitude used to generate VDI; pilot may follow guidance to LNAV minima regardless of temperature.
- 3) **LNAV Mode and VNV1-B or VNV2-B:** Default FMS barometric VNAV mode. Using barometric altitude to generate the VDI, pilot may follow guidance to LNAV minima as long as the specified temperature is within limits.
- 4) **GS1 or GS2:** Glideslope receiver #1 or #2 as indicated. Pilot follows guidance to published barometric DH.

Table RD-4: Vertical Deviation Indicator Behavior

Source (Below VDI)	Behavior/Condition	Pointer Color
FMS	Conforms to the VDI display	Magenta
Glideslope	Source must be valid when a valid glideslope is received.	Magenta
LPV or VNAV mode	Source is valid if: On VNAV descent segments when approaching top of descent point to provide descent anticipation as long as the following are true: 1) On VNAV descent segments; or 2) If the vertical deviations on VNAV level segments option is enabled, on VNAV level segments; or 3) If the vertical deviations on VNAV level segments option is disabled, when approaching the Top of Descent point to provide descent anticipation; Providing: 1) Aircraft is within 2NM or twice the full scale deflection for the mode of flight (whichever is greater) of the lateral navigation route; and 2) Aircraft is in TO operation relative to the active VNAV waypoint (i.e., taking into account VNAV offsets); and 3) If on the final approach segment, aircraft is within a 35° lateral wedge of the azimuth reference point (either GARP or MAWPT + 10,000 ft.).	Magenta
LPV,VNV-G	During GPS LON or GPS VLON	Pointer and Text Color Amber (Yellow)



Figure RD-35: VDI Color during GPS/SBAS LON or VLON

RD 1.19. Course Deviation Indicator



NAV Source VLOC1



NAV Source FMS1 with LON

Figure RD-36: Course Deviation Indicator

The order of precedence of type accuracy used by the system from highest to lowest is as follows:

- 1) Manual RNP: The pilot may override the automatic accuracy types by setting a manual RNP value.
- 2) Automatic RNP: These are based upon RNP values, which are coded in the navigation database. The EFIS looks at the leg coding on all legs other than those on the final approach segment. On the final approach segment, the EFIS looks at the “Level of Service” record for those approaches, which have RNP transition legs, and then goes to LP or LPV minima for the final approach.
- 3) Default TSO-C146C operation: As specified as per Table RD-5 for enroute, terminal, and various approach modes according to the Level of Service record.

Table RD-5: CDI Behavior and Color



CDI Pointer and Condition	Color or Behavior
Full Scale Deflection	Flash
Slaved to GPS/SBAS	<p>Scale is appropriate FSD value for mode of flight:</p> <p>Enroute: ± 2NM</p> <p>From Enroute to Terminal: Change from ± 2 NM FSD to ± 1 NM FSD over distance of 1 NM; start transition when entering terminal mode.</p> <p>From Terminal to Enroute: Change from ± 1 NM FSD to ± 2 NM FSD over distance of 1 NM; start transition when entering enroute mode.</p> <p>From Terminal to Approach: If VTF, switch immediately.</p> <p>Otherwise, change from ± 1 NM FSD to approach FSD over distance of 2 NM; start transition at 2 NM from FAWP.</p> <p>From Approach to Terminal: Change to ± 1 NM.</p> <p>From Departure to Terminal: If initial leg is aligned with runway, change from ± 0.3 NM FSD to ± 1 NM FSD at the turn initiation point of the first fix in the departure procedure.</p>
CDI images below represent installations with Genesys/S-TEC DFCS integrated autopilot or without an autopilot enabled.	
	Nav source FMS1 GPS/SBAS (with GPS LON) amber (yellow) OBS manual mode with a "FROM" indication.
	Nav source FMS1 GPS/SBAS (with GPS LON) amber (yellow) OBS automatic mode with a "TO" indication.
Normal conditions	Magenta
In FMS LP/LPV mode or VOR/VLOC approach mode	Angular scale annunciation
	Nav source is localizer (course error exceeds 105°). Reverse sensing with distance to approach threshold

Table RD-5: CDI Behavior and Color

CDI Pointer and Condition	Color or Behavior
Lateral deviations in failed state	Red "X" displayed over CDI
FMS1 1.0NM ○ ○ ↑ ○ ○ 076° A	Nav source FMS1 in auto waypoint sequencing mode
FMS1 2.0NM ○ ○ ↑ ○ ○ 344° M	Nav source FMS1 in manual OBS mode with a "TO" indication. Waypoint sequencing is suspended.
FMS1 2.0NM ○ ○ ↓ ○ ○ 344° M	Nav source Fms1 in manual OBS mode with a "FROM" indication. Waypoint sequencing is suspended.
FMS1 2.0NM ○ ○ ↑ ○ ○ 142° A	Nav source FMS1 in automatic OBS mode with true north mode. Only applicable for CDI in this GPS/SBAS navigation source.
LOC1: 5.7NM ANG ○ ○ ↑ ○ ○ 078°	Nav source VLOC1
LOC2: 4.9NM ANG ○ ○ ↓ ○ ○ 078°	Nav source VLOC2
VOR1: 289° / 14.6NM ANG ○ ○ ↑ ○ ○ 289°	Nav source VOR1 with "TO" indication. Currently on a bearing 289°/14.6NM to the VOR
VOR1: 344° / 1.1NM ANG ○ ○ ↓ ○ ○ 164°	Nav source VOR1 with a "FROM" indication on a bearing of 344° to the VOR
VOR2: 145° / 46.3NM ANG ○ ○ ↑ ○ ○ 145°	Nav source VOR2 with "TO" indication on a bearing of 145°/46.3NM to the VOR

When laterally integrated with an autopilot, either fully integrated Genesys/S-TEC DFCS or partially integrated through use of the NAV/APR mode discrete input with either the NAV, LOC, APPR or BC modes engaged, the selected navigation source is annunciated green to indicate that the autopilot is laterally coupled to the selected navigation source. Otherwise, the selected navigation source will be annunciated white.

Table RD-6: CDI Lateral Mode Indication

CDI Pointer and Condition*	Color or Behavior
1.0NM ○ ○ ↑ ○ ○ 179° A NAV: FMS HDG: BUG	Heading bug sub-mode guidance
1.0NM ○ ○ ↑ ○ ○ 179° A NAV: FMS HDG: LNAV	LNAV sub-mode guidance

Table RD-6: CDI Lateral Mode Indication

CDI Pointer and Condition*	Color or Behavior
	Failure Sub-Mode
* Installations with an analog autopilot enabled.	

RD 1.20. Vertical Deviation Indicator (EFIS Coupled)

When vertically integrated with Genesys S/TEC DFCS enabled through glideslope mode discrete input with glideslope mode engaged, the selected vertical navigation source is green indicating the AP is vertically coupled. Otherwise, the source is white.



Figure RD-37: EFIS Coupled Vertically with Glideslope Mode

When not decluttered, the PFD displays the active navigation route or manual OBS course in 3D with a series of skyway boxes, which overly the flight plan route at a desired altitude and provide lateral and vertical guidance. See Section 7 IFR Procedures for details.

RD 1.21. Active Waypoint and Waypoint Identifier

See Section 3 Display Symbology for more information.

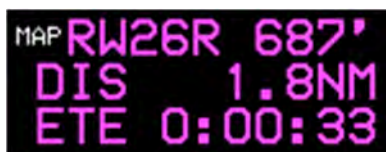

Figure RD-38: Active Waypoint

RD 2. GPS Failure

GPS degrades or fails because of loss of satellite information or GPS equipment failure. When SBAS provides the integrity, the IDU provides a loss of integrity (LOI) caution within two seconds if the current horizontal protection level (HPL) exceeds the horizontal alert level (HAL).



LOI caution appears when there is no integrity monitoring and disappears when it is restored.

Figure RD-39: Loss of Integrity (LOI)

Further GPS degradation causes the EFIS to lose GPS updating of aircraft position, groundspeed, and ground track, and the ability to calculate the wind information.

- 1) **LOI** (Loss of Integrity) displayed with no time delay.
- 2) $HPL > HAL$ for the phase of flight currently in. Position is still presented based upon a GPS navigation solution.
- 3)  (Loss of Navigation) displayed with no time delay of the onset of the following:
 - a) The absence of power;
 - b) Equipment malfunction or failure;
 - c) The presence of a condition lasting five seconds or more where there are an inadequate number of satellites to compute position solution;
 - d) Fault detects a position failure that cannot be excluded within time-to-alert when integrity is provided by FDE;
 - e) $HPL > HAL$ on the final approach segment. Genesys Aerosystems EFIS does not transition to DR navigation at this stage. A GPS navigation solution is still presented; and
 - f) Where $HPL > HAL$ on the final approach segment, this position may still be satisfactory for GPS navigation. For example, an HPL of 0.31NM exists, which means as soon as a transition to terminal mode occurs, all alerts disappear. This is significantly important during a wind change if the system had been in a DR mode.

NOTE:

At any time and on any IDU, view HFOM on the FAULTS page to see the system-reported accuracy.

4) Loss of Vertical Navigation



Figure RD-40: Loss of Vertical Navigation (VLON)

RD 3. Red-X (Invalid Input)

The following round dial items on the PFI have a red-X in case of invalid input:

- 1) G-Meter
- 2) Turn Indicator
- 3) Balance Ball

RD 4. PFD Failure Mode 0

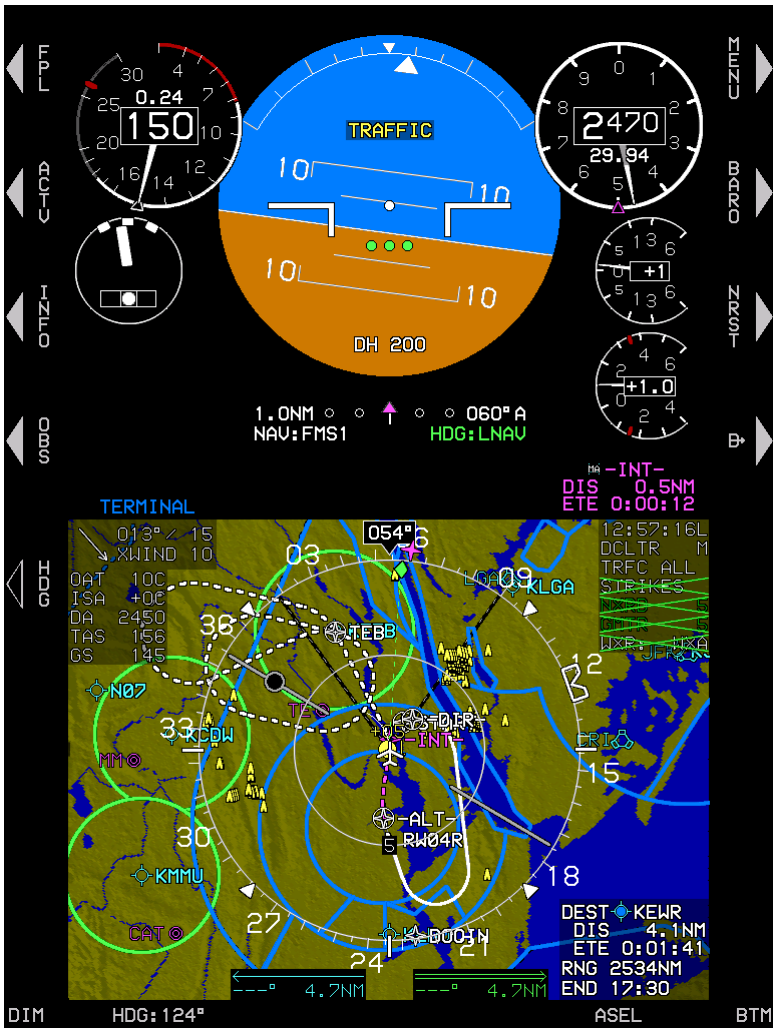
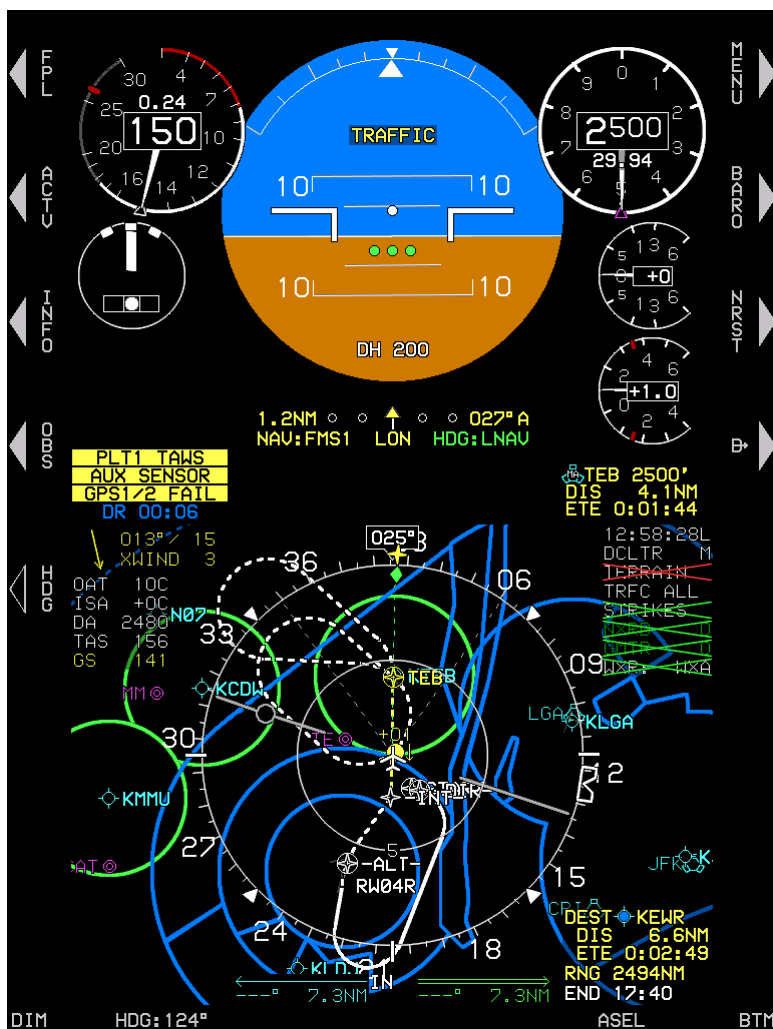

Figure RD-41: PFD Failure Mode 0
GPS, ADC and AHRS Normal

RD 4.1. PFD Failure Mode 1



**Figure RD-42: PFD Failure Mode
GPS/SBAS Failed, ADC and AHRS Normal**

Search and Rescue (SAR) Patterns

SAR 1. Search and Rescue (SAR) Patterns

When enabled by EFIS system limits, the pilot can create one SAR pattern at an eligible flight plan waypoint and only one waypoint within the active flight plan. The current position of the aircraft is determined relative to that desired path for lateral deviation for display on the GPS/SBAS CDI. In most cases, the IDU auto-sequences from one waypoint to the next similar to all other flight plan sequencing along the flight path.

The SAR option is available for any waypoint except the following:

- 1) Suppressed waypoint
- 2) Skipped waypoint
- 3) Manual termination waypoint
- 4) Waypoint that is part of an IFR or VFR approach
- 5) Holding pattern waypoint
- 6) SAR pattern exit waypoint
- 7) Waypoint that begins a departure procedure
- 8) Parallel offset entry or exit waypoint
- 9) Dynamic termination waypoint (altitude termination, DME termination, radial termination or intercept termination)

SAR patterns can be created in the **RUN DEMONSTRATOR/TRAINING PROGRAM** Ground Maintenance Page or the EFIS Training Tool. After the SAR pattern is created and saved, that flight plan can be uploaded to any IDU or all IDUs in an aircraft for later use.

The desired flight path is created from a sequence of straight, left, and right turning leg segments to provide smooth skyway, GPS/SBS CDI, and lateral autopilot guidance. SAR patterns are drawn at the lowest of holding or procedure speed.

SAR 1.1. SAR Pattern Step-by-Step Procedures

To select a SAR pattern, follow these step-by-step procedures. Refer to subsequent sections for additional details and examples for the individual patterns.

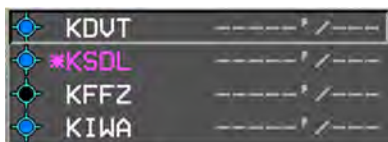

1) Press **ACTV (L2)** and rotate **1** to desired eligible waypoint to begin SAR pattern creation process and push to enter.



2) Press **ACTV (L2)** and then rotate **1** to **SAR PTRN..** and push to enter.

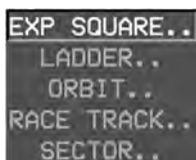

3) Rotate **1** to one of the five SAR pattern options and push to enter.
*Pattern includes the option to select individual legs within the SAR pattern for navigation guidance.

- a) Expanding Square*
- b) Rising Ladder*
- c) Orbit
- d) Race Track
- e) Sector Search*



4) Rotate **1** through each step, create the desired parameters (e.g., direction, track, leg length, leg spacing, and number of legs), and push to enter.

See following sub-sections for more details for parameters of each pattern.



- After SAR pattern is created, it appears on the map, mini map, and active flight plan.



- To select a SAR pattern individual leg, rotate **1** to SAR pattern EXIT WPT as it appears in magenta and push to enter.



- Rotate **1** to **SAR SGMNT..** and push to enter.



- Rotate **1** to desired leg for navigation guidance.



9) Control the aircraft to new magenta line for maneuvering to begin following navigation guidance.

See § SAR 2, SAR 3, and SAR 6 for examples of selected segments.

10) To delete existing SAR pattern, Press **ACTV (L2)**. Rotate **1** to SAR pattern and press **DELETE (R3)**.

11) Push **1** to confirm.

SAR 2. Expanding Square Pattern



Figure SAR-1: Expanding Square Pattern



Figure SAR-2: Expanding Square Pattern Parameters

Table SAR-1: Expanding Square Pattern Parameters

Parameters	Increments (Range)/Direction	Notes
Initial Turn	Left or Right	
Initial Track	Outbound from previous waypoint in 1° increments	Magnetic or True
Leg Spacing	0.25NM (0.25 to 10NM)	
Number of Legs	1 to 50	

**Figure SAR-3: Expanding Square Pattern-Turn and Leg****Figure SAR-4: Expanding Square Pattern-Individual Leg Selected**

SAR 3. Rising Ladder Pattern



Figure SAR-5: Rising Ladder Pattern

LADDER PATTERN	
INIT TURN:	LEFT
INIT TRACK:	348°
LEG LENGTH:	15.0 NM
LEG SPACING:	2.00 NM
NUMBER OF LEGS:	10

Figure SAR-6: Rising Ladder Pattern Parameters

Table SAR-2: Rising Ladder Pattern Parameters

Parameters	Increments (Range)/Direction	Notes
Initial Turn	Left or Right	
Initial Track	Outbound from previous waypoint in 1° increments	Magnetic or True
Leg Length	0.5 NM (1NM to 100NM)	
Leg Spacing	0.25NM (0.25 to 25NM)	
Number of Legs	1 to 50	



Figure SAR-7: Rising Ladder Pattern-Turn, Leg, and Track



Figure SAR-8: Rising Ladder Pattern-Individual Leg Selected

SAR 4. Orbit Pattern



The SAR exit waypoint is a duplicate of the previous waypoint. This SAR pattern is unique in that the navigation path never goes through the waypoint. The path is a circle around the waypoint intercepted along tangents. With no other menus displayed on the PFD, **CONT (L6)** appears to allow for continuing out of the orbit and normal sequencing in the active flight plan.

Figure SAR-9: Orbit Pattern



Figure SAR-10: Orbit Pattern Parameters

Table SAR-3: Orbit Pattern Parameters

Parameters	Increments (Range)/Direction
Turn Direction	Left or Right
Radius	0.25NM (0.25NM to 10NM)

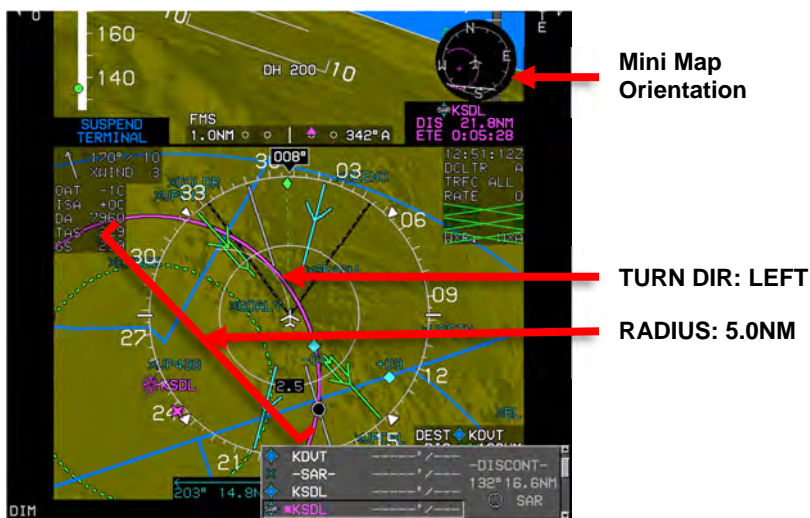

Figure SAR-11: Orbit Pattern-Turn and Radius

SAR 5. Race Track Pattern



With no other menus displayed, **CONT (L6)** appears for continuing out of the racetrack and normal sequencing in the active flight plan.

Figure SAR-12: Race Track Pattern

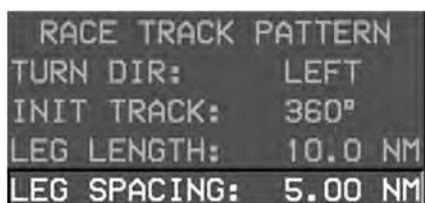

Figure SAR-13: Race Track Pattern Parameters

Table SAR-4: Race Tack Pattern Parameters		
Parameters	Increments (Range)/Direction	Notes
Initial Turn	Left or Right	
Initial Track	Outbound from previous waypoint in 1° increments	Magnetic or True
Leg Length	0.5 NM (1NM to 100NM)	
Leg Spacing	0.25NM (0.25 to 10NM)	



Figure SAR-14: Race Tack Pattern-Turn, Leg, and Track

SAR 6. Sector Search Pattern



Figure SAR-15: Sector Search Pattern

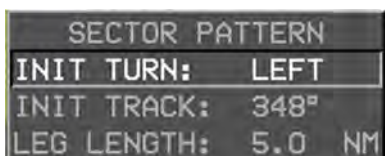

Figure SAR-16: Sector Search Pattern Parameters

Table SAR-5: Sector Search Pattern Parameters		
Parameters	Increments (Range)/Direction	Notes
Initial Turn	Left or Right	
Initial Track	Outbound from previous waypoint in 1° increments	Magnetic or True
Leg Length	0.5 NM (1NM to 100NM)	

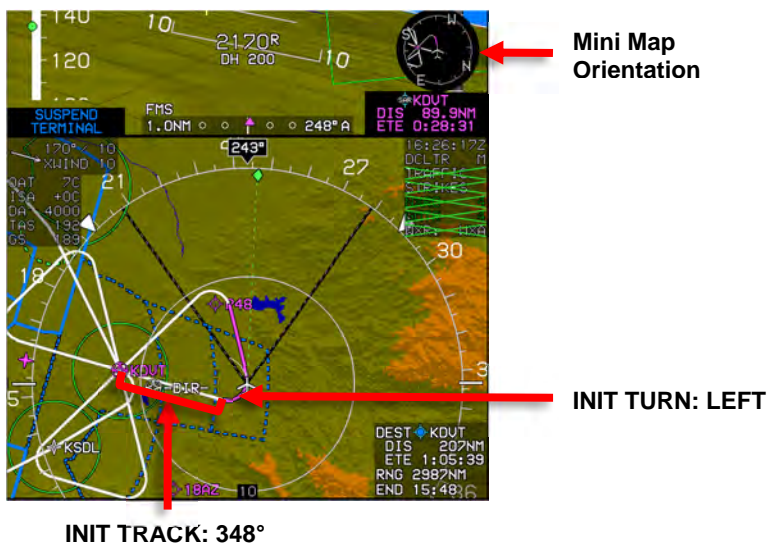

Figure SAR-17: Sector Pattern-Turn and Track



Figure SAR-18: Sector Search Pattern-Individual Leg Selected

INDEX

500-Foot Wake-Up Call	3-7, 3-13, 5-72, 7-33, 8-2, 8-6, 8-16
ADAHRS	2-1, 2-18, 2-23, 3-59, 9-2 to 4
ADF	2-1, 2-13, 3-58, 5-19, 5-80 to 81
ADS-B (ADSB).....	2-1 to 2, 2-12, 2-16, 2-34, 5-75, T-4 to 5, T-8 to 9, D-2 to 4, D-11 to 12
AGL Indication	3-12 to 13, RD-4
Air Data	2-1, 2-38, 3-7, 3-46, 3-59, 4-8, 8-16 to 17, 8-22, 9-17, D-4, WX-11
Aircraft	
In the Air	2-22, 2-49, 5-60 to 61, 7-1, 9-16, WX-1
On the Ground.....	2-20, 2-36, 2-41, 2-50 to 51, 3-8, 3-29, 3-40, 3-54, 5-60 to 61, 6-2
Referenced.....	7-11
Airport.....	2-35, 3-8, 3-28, 3-40 to 41, 3-54, 5-11, 5-28, 5-37, 5-42, 5-46 to 47, 5-58 to 61, 5-72, 6-2, 6-7 to 8, 7-2, 7-6 to 8, 7-22, 7-27 to 28, 7-41 to 45, 7-50, 7-55, 7-61, 7-66, 7-73, 7-76 to 77, 7-82, 7-87, 8-18, 9-2, 9-11, T-8, D-2 to 3, D-8 to 11, WX-9, RD-10
Airspace	3-49, 4-4, 5-52, 5-74, 5-81, 7-34
Depiction	3-48 to 49
Airspeed	
Bug	3-11 to 12, 3-15, 5-3, 5-66 to 67, RBP-2 to 3, RD-6
Display.....	3-14, 3-18, RD-6, RD-16
Miscompare Threshold.....	9-5 to 6
True	2-6, 2-9, 2-12, 3-47, 4-3 to 5, 7-13 to 14
Airway(s)	2-47, 3-49, 3-64, 5-37, 5-81
AIU	2-13, 5-75
Altimeter	
Menu.....	5-9, 5-72 to 73
Setting	2-41, 3-7 to 8, 5-72, 9-2, RD-9 to 10
Altitude	
Bug Menu (ASEL)	2-1, 3-8, 5-10, 5-55 to 56, 7-67
Capture Predictor	3-55, T-7, D-7
Display.....	3-7 to 9, T-5, RD-10 to 12
Minimum.....	2-45, 3-10 to 11, 5-3, 5-66, 7-56, RBP-2 to 3

Miscompare Threshold	1-3, 9-4 to 5
Sub-Mode.....	3-8 to 10, 5-11, RD-11
Target.....	2-1, 3-8 to 10, 3-40, 5-55, 5-70, T-7, RBP-1 to 3, RD-11
Amber (Yellow) ..	2-27 to 29, 2-45, 3-10, 3-14 to 18, 3-27, 3-34, 3-38 to 41, 3-48 to 50, 3-56, 3-60 to 63, 7-1, T-7 to 8, D-2, D-5 to 8, RD-5, RD-18 to 20
Analog AGL Indicator (ANLG AGL)	3-13, 5-70, 6-2
Analog Navigation Symbolology.....	3-50 to 51, 3-54, 3-61, 6-3
Approach	2-1 to 7, 2-37, 3-34, 3-44, 5-29, 6-7 to 8, 7-7, 7-12 to 13,7-26 to 39, 7-44, 7-49, 7-54, 7-60, 7-65, 7-72, 7-76, 7-81, 7-86, 7-89, 8-1, 8-4 to 6, 8-13, 9-10, D-2, RD-20
APPR	2-1, 6-8, 7-26, 7-79, RD-21
APV	2-1, 7-7
ARM	2-14, 2-43, 3-34, 5-12, 7-8, 7-48, 7-51, 7-57, 7-62, 7-69, 7-74,7-79, 7-84, 7-88
Atmospheric Perspective	3-2, 3-24 to 27
BACK	3-6, 5-2, 5-32, WX-18, WX-22, WX-26 to 28, WX-32 to 33
Bank Scale (BANK SCL)	3-30, 5-62, 5-70 to 71
BARO.....	2-2, 2-13, 2-20, 3-8, 5-4, 5-9, 5-72 to 75, 6-1 to 2, 7-7 to 8, 9-2
BARO-VNAV.....	7-7
Basic Mode	3-2, 3-23 to 25, 3-29 to 33, 5-4, 5-70, 7-9
Blue.....	2-28, 3-24 to 27, 3-50, 3-53, 3-62, 7-40, 7-44, 7-49, 7-54, 7-60, 7-65, 7-72, 7-81, 9-1, D-2 to 3, RD-8
Borders	2-28, 3-51 to 52, 5-81, D-8
Boundary Circle	3-45, 3-59, T-7, D-4 to 7
Brown.....	2-27, 3-7, 3-25 to 27, 3-53
BUGS.....	2-50, 5-15, 5-65 to 67, 7-7, 7-56
Button/Menu/Encoder Functions	1-3, 3-5 to 6, 3-56, 5-1, 8-2, T-10,RBP-2, S-5, D-10 to 12, WX-33, V-2
CENTER/ARC	5-80
Compass Rose	3-32 to 33, 3-45, 3-58 to 60, 4-3 to 5, 7-21 to 22, 9-2 to 4, T-6 to 7, D-4, RD-14 to 15
CONFIRM DEL	5-27, 5-32, 6-6
CONT.....	2-2, 2-44, 5-11, 7-8, 7-59, 7-71, 7-91

Course Deviation Indicator (CDI)	2-2, 2-27, 3-12 to 14, 3-24, 3-33 to 36, ... 3-49, 3-56, 3-60, 4-2, 4-5, 5-51, 6-3, 7-8, 7-13, 7-25 to 27, 7-30, 7-34, 7-47, 7-50, 7-56 to 58, 7-70, 7-79, 9-13, T-8, D-7 to 8, RD-4, RD-19 to 21
Scale.....	3-60, 7-27
CRS SYNC.....	5-49, 5-58
Cyan.....	2-27, 3-41, 3-50, 3-58 to 61, 7-58, D-2, WX-10
Database	
Jeppesen.....	1-3, 2-47, 2-50, 3-27, 9-6
NavData®.....	2-47 to 49, 3-40, 5-5, 7-3, 7-7, 7-14, 9-6, 9-16
Navigation	2-27, 2-43, 2-47 to 50, 3-33, 3-41 to 42, 3-64, 7-1, 7-7, 7-10, 7-14 to 15, 7-18 to 19, 7-33, 8-9, 8-19 to 20, 9-7 to 8, RD-19
Obstruction	2-23, 2-47 to 50
Terrain	2-36, 2-50, 8-19 to 20
Update	1-2, 2-50
Datalink	1-3, 2-3, 2-12, 2-18, 3-43, 3-50, 5-3, 5-10, 5-19, 5-45, 5-50, 5-78, D-1 to 12, WX-2
Page (DATALINK)	5-78 to 79, D-4, D-9 to 10
DCLTR	2-2, 3-46, 5-5, 5-15, 5-19, 5-69 to 71, 5-80 to 81, 5-84, T-1 to 2, T-9, D-9 to 10, WX-3 to 5, WX-28, V-2
DCND.....	2-2, 5-68
Dead Reckoning (DR).....	2-3, 2-43 to 45, 4-7 to 8, 7-22
Decision Height (DEC HT) ..	2-2 to 3, 2-45, 3-12 to 14, 5-3 to 4, 5-66 to 68, RBP-2 to 3, RD-5
DELETE	5-27, 5-32, 5-39, 6-6 to 8
Demonstrator	2-50 to 51, 9-16
Density Altitude	3-47, 4-3 to 5
Departure	1-3, 2-3, 2-7 to 9, 2-37, 3-34, 3-64, 7-2 to 7, 7-13, 7-25 to 28, 7-37 to 41, 7-92, 8-3 to 6, 8-20, 9-2, 9-6, RD-20
DESIG	2-3, 5-14, 5-19, 5-22, 6-5
DG Mode.....	3-20, T-6, RD-14
Direct.....	2-3, 3-54 to 55, 3-65, 5-9 to 11, 5-44, 5-47, 5-59 to 61, 6-2, 7-15, 7-19 to 20, 7-23 to 24, 7-28, 9-20
Direct-To	3-54, 3-65, 5-11, 5-44, 7-15, 7-19 to 20, 7-23 to 24, 7-28
Discontinuity.....	3-64 to 65, 5-39, 5-60, 7-3, 7-14 to 15, 7-19 to 20, 7-23 to 24, 7-33 to 34

DME	2-2 to 3, 2-10, 2-13, 2-27, 2-41, 3-35, 3-49 to 50, 3-55, 3-62, 3-65, 7-4 to 5, 7-13 to 17, 7-20, 7-38, 7-54, 7-81 to 84
DONE.....	5-64, 5-71, 5-80, 5-84, WX-28
Download.....	9-7 to 8
DP	2-3, 3-41, 3-64, 5-28, 7-3, 7-6 to 7, 7-13 to 16, 7-23, 7-38 to 41, 8-3, 9-10
EFIS Training Tool (ETT).....	1-3, 2-3, 2-51, 9-15 to 16
EICAS	2-14, 2-24, 2-33, 4-6
Enroute	2-3, 2-37, 2-47, 3-33 to 34, 3-40, 3-49, 3-64, 5-33, 7-7, 7-14, 7-25 to 28, 7-35 to 36, 8-3 to 6, 9-6, 9-13, RD-19 to 20
Enter Identifier	5-31, 5-38
Estimated Time Enroute (ETE).....	2-3, 3-47, 3-65 to 66
Estimated Time of Arrival (ETA).....	2-3, 3-47, 3-66, 5-5, 5-34, 5-81
EXIT	2-22, 3-6, 5-2, 5-10, 5-25 to 34, 5-64, 5-68, 5-71, 5-80, 5-84, 6-2, 6-5 to 6, 7-56 to 57, WX-18, WX-22, WX-26 to 33
EXPAND CAS.....	2-46, 5-19
FAF ...	2-3, 3-63, 7-12, 7-47, 7-48 to 50, 7-57, 7-61 to 62, 7-68 to 69, 7-74, 7-78 to 79, 7-84, 7-88, 8-9
FAULTS	4-7, 5-19, 5-33, 5-74 to 76, T-10, D-12, WX-13, RD-24
FAWP.....	2-3, 2-44, 2-48, 3-34, 4-8, 7-26 to 28, 7-31 to 37, RD-20
Field of View (FOV)	2-4, 2-29, 3-24 to 26, 3-29, 3-53, 3-57, 5-15, 7-63, 7-70
Zoom	2-19, 3-24, 3-57, 5-15, 7-48, 7-63, 7-70, 7-85
Fixes	3-40, 3-49, 5-38, 5-44, 5-57 to 58, 5-81, 7-92, 9-12
Flight Path Marker (FPM) .	2-4, 3-2, 3-21 to 24, 3-28 to 30, 4-2, 5-68 to 70, 9-1, 9-4
Flight Plan....	1-3, 2-4, 2-18, 2-35, 2-42, 2-48 to 51, 3-39, 3-47, 3-54 to 56, 3-63 to 66, 5-9 to 11, 5-14, 5-21 to 28, 5-33 to 44, 5-57 to 61, 6-1, 6-4 to 8, 7-1 to 3, 7-8 to 10, 7-14 to 15, 7-19 to 24, 7-29, 7-37, 7-45 to 46, 7-66 to 68, 7-71 to 73, 7-76 to 77, 7-89 to 92, 8-18, 9-1 to 2, . 9-6 to 12, 9-15 to 16, T-8 to 9, S-3 to 4, D-7 to 9, WX-5, WX-9, RD-22, SAR-1 to 3, SAR-7 to 8
Activate	5-25, 6-4
Active (ACTV)	2-1, 2-27, 3-56, 4-3, 5-4, 5-9, 5-28, 5-35 to 37, 5-40 to 42, 5-47, 5-58, 6-5 to 7, 7-1 to 3, 7-10, 7-19, 7-41 to 46, 7-50, ... 7-55 to 57, 7-61, 7-66, 7-73, 7-82, 7-87 to 88, 9-10 to 11, T-8, D-7, D-11, WX-9
CREATE-EDIT	5-21 to 33, 6-5

Delete	5-27
FPL	2-4, 5-9, 5-21 to 33, 6-4 to 5
Limits	5-21
Path	3-55 to 56, 5-11, 7-1, T-8, S-3 to 4, D-7 to 8, WX-9
Reverse	5-26
FLTA ...	2-4, 2-25, 2-30 to 33, 2-36, 2-39 to 40, 2-44, 3-26, 3-53, 5-2, 5-11, 7-80, 8-1 to 8, 8-20 to 28, WX-1 to 2
FMS.....	1-1, 2-4, 2-16, 2-19, 2-42, 3-31, 3-34, 3-37, 3-59 to 64, 5-4, 5-50 to 52, 5-78, 6-3, 6-6, 7-1, 7-5, 7-29, 7-47, 7-50 to 52, 7-58, 9-8, 9-12 to 14, WX-34, RD-2, RD-17 to 20
FORMAT	5-19, 5-83 to 84, T-1 to 2, T-9 to 10, D-10, V-2
Fuel Remaining.....	3-48, 3-63, 3-66
Geodesic Path	7-18 to 19, 7-22
Geo-Referenced	7-11
Glideslope ..	2-5, 2-13, 2-26, 2-30 to 37, 2-40 to 42, 3-37 to 39, 3-61, 7-33, 7-48, 7-51, 7-77 to 79, 8-2, 8-15 to 23, 9-11, RD-17 to 18, RD-22
GPS.....	2-4, 2-13, 2-21 to 23, 2-26, 2-36 to 37, 2-41 to 45, 3-12, 3-20, 3-34 to 41, 3-46 to 48, 3-53, 3-56 to 60, 3-63, 4-1, 4-4 to 29, 5-33 to 34, ..5-51, 5-64, 5-74 to 76, 7-1, 7-7 to 9, 7-13, 7-22, 7-25 to 29, 7-32 to 33, ..7-38, 7-60 to 62, 7-65 to 66, 7-69, 7-73, 7-79, 7-84, 7-92, 8-3 to 6, 8-9, ... 8-13, 8-16 to 22, 9-3 to 6, 9-9, 9-17, T-7 to 8, RBP-2, D-7 to 8, RD-4, RD-15 to 26
ALMANAC	5-75
Altitude.....	7-22
EQPMNT	5-74
FDE	5-74
HFOM	5-75
HPL.....	5-74
LOI.....	5-74
LON	3-34, 3-38 to 40, 3-48, 3-56, 3-60, 3-63, 7-1, T-7 to 8, D-7 to 8, RD-18 to 20
PWR	5-74
SATLT	5-74
TRK	4-5, RD-15
VFOM	5-75
VPL.....	5-75

GPS/SBAS.....	2-23, 2-36 to 37, 2-41 to 45, 3-12, 3-34 to 37, 3-41, 3-46, 3-53, 3-56 to 57, 3-60, 4-1, 4-4, 4-11 to 29, 5-33 to 34, 5-74 to 75, 7-8 to 9, 7-13, 7-22, 7-25 to 27, 7-33, 7-38, 7-69, 8-3 to 6, 8-9, 8-13, 8-16 to 22, T-7 to 8, D-7 to 8, RD-4, RD-19 to 21, RD-26
Navigation Mode	7-25 to 26, 8-3
GPWS Modes	2-30 to 33, 2-39 to 42, 8-1 to 2, 8-10 to 17, 8-20, 8-23
Gray	2-26 to 28, 3-7, 3-16 to 18, 3-42, 3-57, 3-64, 7-45, 7-50, 7-61, 7-66, 7-88, T-8, D-2 to 3, D-8, WX-10, RD-7 to 8
Green ..	2-27, 3-9 to 18, 3-39 to 41, 3-50, 3-55, 3-58 to 62, 6-2, 7-47 to 48, 7-52, 7-58, 7-63, 7-68, 7-83, T-4, T-7, D-2 to 7, WX-10, V-2, RD-5 to 8, RD-13, RD-21 to 22
Groundspeed	2-26, 2-35 to 37, 3-19, 3-46 to 48, 3-55, 3-59, 3-63 to 65, 4-3, 4-6 to 8, 7-9, 8-3 to 6, 8-9, 8-17, T-7 to 9, D-4, D-7, WX-11, RD-23
Heading	
Display	3-19, RD-14
Heading Up (HDG UP).....	3-45, 4-4, 5-81 to 83, 8-8
North Up (N UP).....	5-81 to 83, WX-2
Pointer.....	3-19, 3-54, T-7, D-7
Heading Bug ...	3-19, 5-3, 5-10 to 11, 5-54, 5-58, 6-1, 7-6, T-7, RBP-2, D-7
Sub-Mode.....	3-36, 5-11, RD-21
Hidden Surface Removal Techniques	3-25, 3-40 to 41, 7-9
Highway in the Sky (HITS)....	1-1, 2-5, 3-2, 3-24, 3-39, 4-2 to 4, 5-41 to 42, 7-8 to 13, 7-61, 7-79, 7-83 to 84, 9-13
Skyway (SKYWAY)	2-19, 2-27, 3-39, 3-56, 5-5, 5-39, 5-60, 5-70, 7-9 to 10, 7-13, 7-20, 9-1, T-8, S-4, D-7 to 8, RD-22, SAR-1
HOLD	3-62 to 64, 7-4, 7-57, 7-89
Holding Pattern	2-43, 3-64 to 65, 5-11, 7-3 to 8, 7-14 to 15, 7-18 to 19, 7-27, 7-37, 7-90 to 91
IAP	2-5, 7-33
IAS ...	2-5, 2-30 to 34, 2-38, 2-50, 3-14 to 15, 4-3, 5-66 to 68, RD-6, RD-13
IFR	
APPR	5-28, 6-7, 7-45, 7-50, 7-55, 7-61, 7-66, 7-73, 7-82, 7-87, 8-18, 9-10 to 12
Procedures.....	3-39, 3-55, 3-59, 5-35, 5-43, 7-1, 7-7, RD-22
ILS.....	2-5, 5-43, 5-49, 5-58, 6-8, 7-8, 7-33, 7-38, 7-43 to 50, 7-76 to 79, 7-89 to 91, 8-2, 8-15 to 17, 8-21 to 22, 9-10 to 15
CONFIRM ACTIVATE.....	5-58, 6-8

NRST ILS 5-58, 6-8, 7-38, 7-47, 7-50, 7-76, 9-11 to 12

INFO....2-5, 5-9, 5-12, 5-24, 5-34, 5-37 to 39, 5-46 to 49, 5-58 to 61, 5-84,
.....D-3, D-11

inHg/mbar..... 2-5 to 7, 2-42 to 43, 3-8, 5-72 to 73, 9-2, RD-9 to 10

Initialization 1-2, 2-17 to 18, 2-22, 2-50 to 51, 6-1, 8-19 to 20, RBP-2,
.....RD-16

International Standard Atmosphere (ISA).....2-6, 3-47, 4-3

Latitude/Longitude 2-6, 2-18, 2-35, 2-47, 3-25 to 26, 5-29, 5-48, 5-81,
.....5-84, 7-22

LNAV.....2-6, 2-43, 2-48, 3-34 to 37, 3-64, 4-8, 5-11, 5-54 to 55, 7-7 to 9,
....7-25 to 26, 7-29 to 32, 7-35 to 36, 7-57, 7-62, 7-79, 7-92, RBP-1 to 3,
.....RD-17, RD-21

Approach2-43, 2-48, 7-25 to 26, 7-30, 7-35

Sub-Mode 3-36, 5-11, 5-55, RD-21

LNAV/VNAV 2-43, 2-48, 3-37, 4-8, 7-7, 7-25 to 26, 7-29 to 32, 7-36,
.....RD-17

Approach 2-43, 4-8, 7-25 to 26, 7-36

Log Files.....2-51, 9-7

Loss of Integrity (LOI) 2-6, 2-45, 4-6, 5-74, 7-36 to 37, 8-16, RD-23

Loss of Navigation (LON)..... 2-6, 2-10, 2-45, 3-20, 4-6, 5-74 to 75, 7-34,
.....8-16, RD-23

LP2-6, 2-43, 2-48, 3-33, 3-36 to 37, 7-7 to 8, 7-25 to 26, 7-29, 7-32,
.....7-36 to 38, 7-60, 7-92, 9-14, RD-17 to 20

LPV2-6, 2-43, 2-48, 3-33, 3-36 to 38, 7-7 to 8, 7-25 to 26, 7-29, 7-32,
.....7-36 to 38, 7-65, 7-69, 9-14, RD-17 to 20

Lubber Line3-54 to 55, T-7, D-7

Magenta 2-27, 3-10, 3-34, 3-37 to 41, 3-56 to 63, 5-41, 6-2 to 4, 7-1,
..... 7-53, 7-58, 7-61, 7-67, 7-83 to 85, 9-9, 9-13, T-7 to 8, D-2, D-7 to 8,
..... WX-10, RD-12, RD-18 to 20

Map

Mini 3-40 to 41, 4-2, D-8, V-4

Moving 3-43 to 44, WX-2

Page (MAP)..... 2-25, 5-2, 5-55, 7-69, 7-83, T-5, WX-1

Marker Beacon(s) 2-26, 3-31, 3-62, RD-2

MENU..... 1-3, 5-9, 5-14, 5-22, 5-62 to 64, 5-67, 5-70 to 71, 5-76, 5-80,
.....5-83 to 84, 6-5, 6-8, 7-48, 7-56, 7-63, 7-70, 7-85, T-1 to 2, D-10,
..... WX-14, WX-19, WX-24, WX-28 to 31

Metric (METERS)..... 3-7, 5-70, RD-12

MFD	1-3, 2-7, 2-11 to 18, 2-22 to 28, 3-1 to 5, 3-32 to 33, 3-43, 3-46, 3-50, 4-3 to 29, 5-3 to 22, 5-33, 5-74 to 84, 6-1 to 8, 7-1, 7-16, 7-19, 9-13, 9-16, T-1 to 2, T-6, T-9 to 11, S-4, D-4, D-9 to 12, WX-1 to 3, WX-13, WX-19, WX-24, WX-33 to 35, V-2 to 5, RD-1, RD-15,
Fault Display	5-74, D-11, WX-13
HSI Pointer.....	3-60
Page (PAGE)	3-32 to 33, 5-18 to 19, 5-78 to 84, T-6, S-2 to 4, D-4, D-11, V-1 to 2
Page Format	5-80 to 83
TO ESSNTL/TO MFD	4-6, 5-9
Minima	7-38, 7-60, 7-65
Minimums (MINS)	2-45, 3-10, 5-66 to 68, 7-56, 7-62, 7-70, D-2
MISS	2-43, 5-11, 7-8, 7-51, 7-57, 7-69, 7-79, 7-84, 7-88
Navigation Display (ND)	2-7, 2-15, 3-43 to 45, 3-61, 5-78 to 80, 5-83, 7-19, 7-92, 8-1 to 2, 8-8, 8-22 to 23, T-1, S-1, D-1, D-4, D-11, WX-2, WX-7
Navigation Log (NAV LOG)	3-43, 3-63, 5-78 to 79, 7-1 to 2, 7-41 to 43, 7-68, 9-10
Columns	3-63 to 66
NDB	2-7, 3-40, 3-49, 3-54, 3-58, 5-24, 5-38, 5-44, 5-58, 6-5, 7-47
Nearest (NRST) Menu	2-7, 3-54, 5-9, 5-24, 5-37 to 38, 5-42 to 47, .. 5-56 to 58, 6-5, 6-8, 7-38, 7-47, 7-50, 7-76 to 77, 9-2, 9-11 to 12, D-3, D-11
NO RESULTS.....	5-37 to 38, 5-42 to 45, 5-56
OASIS	2-14, 2-20, 2-24, 2-33, 4-6, 5-15, 5-20 to 21, WX-3
Obstruction(s)	2-20, 2-23, 2-30 to 33, 2-40, 2-47 to 50, 3-2, 3-24 to 27, 3-53, 7-7, 8-3, 8-23, 8-27 to 28
ODP	2-7, 7-7
OFF.....	5-11, 5-14 to 15, 5-29, 5-37, 5-56, 5-61 to 63, 5-66 to 67, 5-71,5-83, T-9, D-10, WX-3 to 5, WX-11 to 28, WX-32, WX-35
Olive.....	2-27, 3-26, 3-53
Omnibearing Selector (OBS).....	2-7, 2-19, 2-43, 3-35, 3-39, 3-56 to 59, 5-3, ... 5-9, 5-50 to 53, 5-58, 6-6, 7-8 to 9, 7-22, 7-54 to 56, 7-77, 7-83, 7-87, 9-11 to 13, T-8, RBP-2, D-7 to 8, RD-20 to 22
AUTO	5-50, 6-6
Manual	3-57, 6-6
Menu	5-50 to 52
SYNC	5-51, 6-6

Operation	
FROM	7-9
TO	3-38, 7-9, RD-18
Outside Air Temperature (OAT)	2-7, 2-26, 2-38, 3-47, 4-3 to 5, 9-20
Ownship Symbol	3-41 to 43, T-3, D-4
Pan Mode	3-54, 5-11 to 14, 5-81 to 83, D-4, D-7 to 11, V-4
PAN ON/PAN OFF	5-81, D-9
Parallel Offsets	3-65, 7-22, 7-25
Parallel Track	2-8, 3-56, 7-24
PFD	1-3, 2-8, 2-11, 2-15, 2-18 to 19, 2-22 to 28, 2-32 to 33, 2-40, ... 3-1 to 2, 3-6 to 7, 3-13, 3-20 to 28, 3-31 to 32, 3-39 to 40, 3-53 to 57, ... 3-61, 4-2, 4-5 to 18, 4-21, 4-24, 4-27, 5-4 to 6, 5-9 to 10, 5-13 to 22, ... 5-33, 5-63 to 70, 5-73, 5-76, 6-1 to 8, 7-7 to 9, 7-16, 7-19, 7-33, ... 8-1 to 2, 8-8, 8-17, 8-22 to 28, 9-3, 9-10, 9-16, T-1, T-5, T-8 to 11, ... D-7 to 8, D-12, WX-1 to 4, WX-14, WX-31 to 34, V-1 to 2, V-5, ... RD-1 to 2, RD-5, RD-15, RD-22, RD-25 to 26,
Background	3-24
Declutter	5-69 to 70, 8-24
Essential Mode	2-24
Normal Mode	2-22
Symbology	3-6
Pitch Scale	3-20, 3-24 to 25, 3-32, 4-2, 9-1, RD-1
Nadir Symbol/Zenith Symbol	3-21
Pop-Up	2-25, 5-2 to 3, 5-11, 8-8 to 9, 8-23, T-5
Primary Flight Information (PFI)	2-8, 2-14 to 15, 2-23 to 25, 2-32, 2-39, ... 2-42, 3-24 to 27, 3-62, 4-5, 5-2, 5-17, 5-56, 5-62, 5-68, 6-2 to 3, 7-48, ... 7-63, 7-69 to 70, 8-17, T-5, RD-24
Procedure Turn	2-8, 3-65, 7-5, 7-15 to 18
Projected Path	3-55 to 56, 4-3
PTK	2-8, 2-44, 3-64, 5-37, 7-23 to 25
PTR	3-59, 5-80
QFE	2-8, 2-20, 2-43, 3-8, 5-4, 5-72, 6-2, RD-10
QNE	2-8, 3-8, 5-72, RD-10
QNH	2-8, 3-8, 5-72 to 73, 6-1, 8-18, 9-11, RD-9 to 10
RAIM	2-2, 2-8, 5-22, 5-33 to 34

Range	2-1, 2-12, 2-35, 3-26, 3-48, 3-57 to 58, 4-3, 8-5, 9-17, T-6, D-3, D-6 to 7, WX-8 to 10, WX-17, WX-25
Re-Centered	5-39, 5-60
Red ...	2-28 to 29, 2-38, 3-7, 3-11, 3-15 to 18, 3-26, 3-34 to 35, 3-50, 3-53, .. 3-60, 4-4 to 5, 5-52, 5-56, 8-22 to 23, T-4, T-8, D-2 to 6, WX-10 to 13, V-2, RD-6 to 8, RD-13 to 15, RD-21, RD-24
Red-X'd	2-38
Remote Bugs Panel (RBP)	1-3, 2-8, RBP-1 to 2
Required Navigation Performance (RNP)	2-8, 2-47 to 48, 3-33, 3-37, 5-51 to 52, 5-74, 7-16, 7-27 to 29, 7-33 to 38, 7-72 to 75, 9-10, 9-17, RD-17 to 19
Automatic (AUTO)	3-33, 7-34 to 35, RD-19
Manual (MAN)	2-19, 3-33, 5-51 to 52, 7-35, RD-19
Reversionary Modes (Failure Modes)	4-1, 4-5, 4-8 to 29, RD-15, RD-25 to 26
RNAV	2-8, 2-48, 7-7, 7-15, 7-33, 7-38, 7-60 to 61, 7-65 to 67, 7-72, 9-9 to 10
Runway	2-9, 2-27, 3-8, 3-34, 3-42, 3-48, 5-28, 5-37, 5-42, 5-48, 5-56, ... 5-72, 6-7 to 8, 7-6 to 7, 7-13 to 15, 7-26 to 28, 7-33 to 34, 7-38 to 39, 7-43 to 45, 7-50, 7-55 to 67, 7-70 to 76, 7-81 to 82, 7-85 to 89, 8-3 to 4, 8-9, 8-13, 8-18 to 20, 9-2, 9-9 to 12, RD-10, RD-20
SAVE	2-51, 5-25 to 26, 5-30 to 32, 5-37, 6-5 to 6, 9-15
SBAS .	2-9, 2-43 to 45, 4-6 to 8, 5-33 to 34, 5-75, 7-7 to 8, 7-22, 7-32, 8-3, 8-18, 8-22, T-8, S-3, D-7 to 8, RD-23, SAR-1
HLTH	5-75
MSG	5-75
Search and Rescue Pattern (SAR)	2-9, 2-12, 2-44, 3-43, 3-64 to 65, 7-3 to 8, 7-14, SAR-1 to 10
Search Envelope	8-3 to 8
SID	2-9, 7-2, 7-7, 7-14
Slip Indicator	1-2, 2-49, 3-19
STAR	2-9, 3-41, 3-64, 5-28, 7-2 to 3, 7-6, 7-13 to 14, 7-38, 7-42 to 43, 8-3, 9-10
START OVER	5-34
STD	2-9, 5-73
SYMB DCLTR	5-81
SYNC	2-9, 5-54 to 56, 5-66 to 67, V-1

Terminal	2-9 to 10, 2-37, 3-34, 3-49, 7-26 to 28, 7-35, 7-38, 7-42, 8-4 to 6, 9-17, RD-20
Terrain.....	2-4, 2-9 to 11, 2-20, 2-23 to 30, 2-33, 2-36, 2-39, 2-50, 3-2, 3-7, 3-24 to 27, 3-40 to 41, 3-46, 3-51 to 53, 4-2 to 3, 5-2, 5-5, 5-11, 5-81, 5-84, 7-8 to 9, 7-85, 8-1 to 14, 8-19 to 26, 9-1, 9-17
Terrain and Obstruction Rendering ...	3-24 to 27, 3-40 to 41, 3-53, 7-9, 8-8
Time	
Clock/Timer	2-21, 2-43, 2-46, 3-31, 4-7, 5-3, 5-61 to 63, RD-16 to 17
COUNT DN	5-61 to 62
COUNT UP.....	5-61 to 62
FLT TIME	5-61 to 62
Local Offset	3-46, T-7, S-3
Menu.....	5-15, 5-19, 5-62 to 63
STORE	5-61
Zulu.....	3-46, 3-59, 3-63, 5-63, 9-7, T-7, S-3, D-4 to 5, WX-11
TO COM.....	5-45, 5-49, 5-57 to 59
TO NAV.....	5-43, 5-48, 5-57 to 59
Top of Climb.....	3-55
Top of Descent.....	2-9, 3-37 to 38, 3-55, 7-46, 7-67, 7-84, T-7, RD-18
Top-Level Menu	5-6 to 10, D-10, WX-3, V-2
Automatic Pop-Up	5-10, D-10
Track Pointer.....	3-19, 3-54, 3-62, T-7, D-7
Traffic	1-3, 2-1, 2-8 to 12, 2-25, 2-30 to 33, 2-40, 3-11, 3-24, 3-43, 4-2 to 3, 5-3, 5-10, 5-19, 5-70, 5-78, 9-17, T-1 to 11, RD-13
Page (TRAFFIC)	5-70, 5-78 to 79, T-1 to 2, T-6
TRFC	5-70, T-8 to 10
TRANS ALT	5-72
Transmit Enabled.....	2-11, 2-32 to 33, 2-40 to 42, 2-47, 4-3, 5-11 to 12, 7-34, D-11
TSO.....	2-10, 2-25, 3-33 to 35, 5-2, 7-7 to 9, 8-1 to 3, 9-17, RD-19
Unusual Attitude Mode.....	2-34 to 38, 2-43 to 45, 3-2, 3-13, 3-22 to 25, 3-29 to 30, 3-36, 3-40 to 41, 7-9, T-6, RD-2 to 3, RD-17
Upload.....	9-8, 9-15
USB.....	1-2, 2-10, 2-49 to 50, 9-7 to 8, 9-16
Vertical Deviation Indicator (VDI)....	2-10, 3-24, 3-36 to 38, 3-60, 7-8, 7-29, 7-46, 7-62 to 63, 7-67 to 69, 7-74, 7-77 to 79, 9-11, RD-17 to 19, RD-22

Vertical Speed Indicator (VSI)	2-6, 2-11, 2-26, 2-34, 2-46, 3-11 to 12, ... 3-15, 4-2, 5-4, 5-67, 6-3, 8-21 to 22, T-4 to 7, RBP-2 to 3, D-7, RD-6, RD-12 to 15
VFR...2-10 to 11, 2-27, 2-37, 2-44, 3-41, 3-48 to 49, 3-64, 5-29, 5-81, 6-7,7-2 to 6, 7-12 to 14, 7-23 to 27, 7-34, 8-3, 8-18 to 20, 9-8, D-2 to 3	
APPR	6-7, 7-26, 8-18
Video.....	1-3, 2-11, 2-23, 5-3, 5-10, V-1 to 5
Page (VIDEO)	2-13, 5-78 to 79, V-1, V-4
VNAV	2-2, 2-10, 2-27, 2-44 to 50, 3-7 to 10, 3-37 to 40, 3-55, 3-61, 3-64 to 66, 5-3, 5-11, 5-40, 5-67 to 68, 7-1 to 12, 7-25, 7-29, 7-32, 7-36,7-67, 7-83, 9-1, T-7, RBP-1 to 3, D-7, RD-12, RD-17 to 18
CDA.....	5-67 to 68
Sub-Mode.....	3-9 to 10, RD-12
VOR	2-10 to 13, 2-19, 2-27, 2-47, 3-35, 3-40 to 41, 3-49 to 50, 3-54,3-61, 4-5, 5-19, 5-24, 5-38, 5-43, 5-58 to 59, 5-80, 6-5, 7-21, 7-38,7-47, 7-50, 7-81 to 84, 9-9, 9-12 to 15, RBP-2, RD-20 to 21
VOR1/VOR2...3-35, 3-44, 3-50, 3-58 to 61, 5-51, 5-80 to 81, 7-83 to 84,	9-13 to 15, RD-21
VTF	2-11, 3-34, 7-26 to 34, 7-54 to 55, 7-60 to 61, 7-87, 9-11 to 12, RD-20
Warnings, Cautions, and Advisories	
ADC FAIL Caution.....	2-34
ADC INIT Advisory	2-41
ADS-B FAIL Caution	2-34
AHRS DG Advisory	2-41
AHRS FAIL Caution	2-34
ALT MISCOMP Caution.....	2-35
ANP Advisory	2-43
ATT MISCOMP Caution.....	2-35
AUX SENSOR Caution	2-34
BARO MISCOMP Advisory	2-41
CHECK GEAR Caution Time-Critical Alert	2-30
CHECK IDU Caution	2-40
CHECK TRIM Down Caution	2-35
CHECK TRIM Up Caution.....	2-35
CHK BARO Advisory.....	2-42

COOLING FAN Caution	2-36
CPLT MISCOMP Caution.....	2-34 to 35
CPLT OVRTMP Caution	2-34
CPLT PWR Advisory	2-41
CPLT SCC Caution	2-36
CPLT TAWS Caution	2-36
CREW CALL Advisory.....	2-41
DR Advisory	2-43
FLTA INHBT Advisory	2-44
FPM INHBT Advisory	2-41
FUEL SPLIT Caution.....	2-36
GLIDESLOPE Caution Time-Critical Alert	2-31
GLIDESLOPE Warning Time-Critical Alert	2-30
GPS FAIL Caution.....	2-36
GPS MISCOMP Caution	2-37
GS MISCOMP Caution.....	2-37
HDG MISCOMP Caution.....	2-37
IAS MISCOMP Caution	2-38
LNAV APPR Advisory	2-43
LNV/VNV APPR Advisory	2-43
LOC MISCOMP Caution	2-38
LOW FUEL Caution.....	2-36
LOW FUEL Warning.....	2-32
LP APPR Advisory	2-43
LPV APPR Advisory	2-43
OAT FAIL Caution	2-38
OBSTRUCTION Caution Time-Critical Alert.....	2-31
OBSTRUCTION Warning Time-Critical Alert.....	2-30
OVERSPEED Warning Time-Critical Alert.....	2-30
PLT MISCOMP Caution	2-34 to 35
PLT OVRTMP Caution	2-34
PLT PWR Advisory.....	2-41
PLT SCC Caution.....	2-36
PLT TAWS Caution	2-36

PTK Advisory	2-44
PTK ENDING Advisory	2-44
PULL UP Warning Time-Critical Alert	2-30
RALT FAIL Caution	2-38
RALT MISCOMP Caution	2-38
RNP Advisory	2-43
SAME ADC Advisory	2-41
SAME AHRS Advisory	2-41
SAME DME Advisory	2-41
SAME GPS Advisory	2-41
SAME NAV Advisory	2-41
SAME RALT Advisory	2-41
SINK RATE Caution Time-Critical Alert	2-30
STALL Warning Time-Critical Alert	2-30
SUSPEND Advisory	2-43
TA ONLY Advisory	2-42
TAS INHBT Advisory	2-41
TAWS GS CNX Advisory	2-42
TAWS INHBT Caution	2-38
TCAS FAIL Caution	2-38
TCAS STBY Advisory	2-42
TCAS TEST Advisory	2-42
TERMINAL Advisory	2-44
TERRAIN Caution Time-Critical Alert	2-30
TOO LOW Caution Time-Critical Alert	2-30
TOTALZR QTY Caution	2-38
TRAFFIC Caution Time-Critical Alert	2-31
TRAFFIC Warning Time-Critical Alert	2-30
TRIM MOTION Down Caution	2-39
TRIM MOTION Up Caution	2-39
TRUE NORTH Advisory	2-44
VECTORS Advisory	2-44
VFR APPR Advisory	2-44
VNAV AVAIL Advisory	2-44

XFILL ARM Advisory	2-42
XFILL FAIL Caution.....	2-39
XFILL INHBT Advisory	2-42
Water.....	2-28, 3-26, 3-53, 9-19
Waypoint	2-1 to 7, 2-10 to 11, 2-27, 2-35, 2-43 to 48, 3-24, 3-38 to 40, 3-47 to 49, 3-54 to 66, 4-2 to 3, 5-11 to 14, 5-21 to 24, 5-29 to 34, .. 5-37 to 41, 5-44 to 49, 5-57 to 61, 5-84, 6-2 to 8, 7-1 to 28, 7-33 to 34, 7-39 to 58, 7-62 to 63, 7-66 to 71, 7-79, 7-82 to 84, 7-87 to 92, 8-3 to 4,8-18, 9-1, 9-8, 9-11, T-7 to 8, S-4, D-7 to 11, WX-11 to 13, RD-18, RD-21 to 22, SAR-1 to 2, SAR-5 to 10
Active.....	2-44, 3-9, 3-13, 3-19, 3-39 to 40, 3-47, 3-56, 3-62 to 63, 3-66, 5-30 to 32, 5-41, 5-47 to 52, 5-57 to 61, 6-2 to 4, 7-1 to 9, 7-13, 7-26 to 28, 7-53 to 55, 7-61, 7-78, 7-83, T-5 to 8, S-4, D-7 to 8, RD-22
ADD	5-23 to 25, 5-37, 6-5
APP	2-1, 3-64, 7-6
Create User	5-29 to 30
Create User (LAT-LON)	5-29
Create User (RAD-DST).....	5-30
Delete User	5-32
Edit User.....	5-31
Fly-By	3-40, 7-9, 7-13 to 17, 7-47, 7-58, 7-83, T-8, D-8
Fly-Over.....	3-40, 5-39, 5-60, 7-9, 7-13 to 19, 7-33 to 34, 7-87, T-8, D-7
INSERT	5-37, 5-57, 6-5, 7-89
MAHWP.....	2-6, 2-48
MAWP	2-7, 2-48, 7-26 to 28, 7-31, 7-38 to 39, 7-52, 7-58 to 70, 7-88
NO RADIUS	7-5
OFLY/AUTO	5-40, 7-5
OVERFLY.....	5-40, 7-5
Overfly User	5-22
Phantom	5-37 to 39, 5-59, 7-19
Pointer	3-54, T-7, D-7
Routes and User	1-3, 9-8, 9-15
Sequencing	2-43, 5-11, 6-4, 7-5, 7-9, 7-13, 7-21, 7-48 to 53, 7-62, 7-69 to 71, 7-79, 7-91, RD-21
Skipped.....	3-65 to 66, 7-3

Suppressed	3-63 to 66, 7-2, 7-21
USER WPT	5-15, 5-23, 5-29 to 32, 6-5
USER WPTS FULL	5-15
WGS-84	2-47, 7-17 to 19, 7-22, 7-33
White.....	2-26, 3-9 to 12, 3-15 to 18, 3-21 to 22, 3-39 to 41, 3-48, 3-51, 3-54, 3-57, 3-64, 7-46, 7-67, D-3, D-7 to 8, WX-10, V-1, RD-1, RD-5 to 8, RD-11 to 15, RD-21 to 22
Wind.....	3-46 to 47, 4-3, 9-3
WX-500 Lightning Strikes ..	1-3, 2-9, 2-12, 2-16, 2-34, 3-43, 4-3, 5-3, 5-10, 5-19, 5-78, 5-81, S-1 to 6
Page (STRIKES)	2-12, 5-78 to 79, S-2 to 3
WX-RDR	5-3, 5-78 to 79, WX-14, WX-19, WX-24, WX-29 to 31
XFILL SYNC	5-14, 6-8

Glossary

AGL Indication (Rad Alt, GPS Alt, Baro Alt) – Display of altitude above the ground, with designation of the altitude source as R (radio altitude), G (GPS WAAS geodetic altitude less local ground elevation), or B (barometric altitude less local ground elevation).

Air Data and Groundspeed – Display of density altitude, outside air temperature, ISA temperature deviation, true airspeed, and groundspeed.

Airspeed Information – Display of airspeed is the indicated airspeed tape and airspeed readout with associated data. The airspeed function includes color-coded caution bands for minimum and maximum speeds based on V-speeds set in the EFIS limits.

Altitude Information – Display of altitude information is the altitude tape and altitude readout.

Approach Mode Signal Output – Conventional autopilot approach mode signals are course error output, the left/right deviation signal (localizer output) and the up/down deviation signal (glideslope output). Signals are based on the selected ILS source.

Attitude Information – Display of attitude information includes pitch and roll. The bank angle scale may be set to auto-declutter by the pilot when the bank angle is less than 2.8°. The pitch ladder is limited to $\pm 10^\circ$ from the flight path marker or aircraft waterline, whichever is greater. The unusual attitude display appears when the aircraft pitch exceeds $\pm 30^\circ$ or bank angle exceeds 65° (fixed wing) or 50° (rotorcraft).

Autoset – Automatically selects features or settings.

Azimuth – Angle between the north vector and the perpendicular projection of the star down onto the horizon. Usually measured in degrees (°).

Barometric Altimetry – Measurement of altitude based on the atmosphere (pressure and temperature).

Barometric Correction – Display and altitude correction for local barometric pressure.

Bezel – Faceplate of the IDU comprised of buttons along the sides and rotary encoders along the bottom.

Chroma – Colorfulness relative to the brightness.

Conformally – Angle-preserving. Example: Traffic appears conformally on the PFD.

Course Deviation Indicator – Display of course deviation from selected course, including a To-From indicator.

Critical Flight Phase – Phase(s) of flight where the failure mode would result in a hazard condition using flight phases. For example, failure of ILS would only be a hazard condition during approach and landing.

Crossfill – Transfer of data and information between IDUs in a dual system with two PFDs configured.

Cross-linked – Synchronized across both EFIS sides.

Datalinked – Display of received data such as weather or traffic from peripheral systems such as ADS-B.

dBZ – Decibel relative to radar reflectivity (Z). Composite reflectivity shows the highest dBZ (strongest reflected energy) at all elevations. Unlike base reflectivity, which only shows reflected energy at a single elevation scan of the radar, composite reflectivity displays the highest reflectivity of ALL elevations scans. If there is heavier precipitation in the atmosphere over an area of lighter precipitation (i.e. rain has yet to reach the ground), the composite reflectivity displays the stronger dBZ level.

Deadband – Neutral zone where no action or changes are made.

Directional Scale (Compass Rose or Arc) and Ownship Symbol – Display of general directional information. All MFD pages include a form of the compass rose with current heading pointer and aircraft “ownship” symbol.

Discrete – A logic input or output that identifies a condition or status of or for an ancillary system. Discretes are defined by the operating software or settings programmed specifically for the aircraft.

Display of ADF – Display of single ADF bearing information in the form of an RMI needle.

Display of Glideslope – Display of Glideslope 1 or Glideslope 2 in the form of vertical deviation dots and deviation on PFD or MFD HSI page.

Display of Lightning Cell Information – Display of lightning information from a WX-500 system and shown in the form of lightning cells. The pilot may show individual lightning strike data by selecting the dedicated WX-500 page.

Display of Localizer – Display of Localizer 1 or Localizer 2 in the form of horizontal deviation dots and deviation.

Display of Marker Beacon – Display of outer, middle, and inner marker beacons in the form of a color-coded circle with the corresponding letter (O, M, I).

Display of Traffic Information – When integrated with an appropriate traffic system, the PFD and MFD display traffic information in two formats. One format is via traffic symbols as shown on the PFD and MFD Map page and Traffic page. The second format is with the traffic pop-up thumbnail display showing traffic position in a full 360° format on the PFD.

Display of VOR RMI – Display of VOR1 and VOR2 bearing in the form of RMI needles.

Dot – (CDI scale referenced) represents an additional 2° for VOR and 1.25° for Localizer.

EFIS-Coupled – The EFIS is coupled to an autopilot and controls the lateral and vertical modes of the autopilot.

Failure Condition Hazard Description – A description of the failure mode to be analyzed.

Flight Director (Selectable Function) – Display of flight director in a single or dual cue format when selected for display on the PFD.

Flight Path Marker (Velocity Vector) – Display of aircraft's actual flight path, showing where the aircraft is going as opposed to where the aircraft is pointed.

Flight Plan and Navigation Display – Display of the active GPS WAAS/SBAS-based flight plan, including course line, waypoints, ground track, glide range, projected path, altitude capture predictor, approach procedure, missed approach procedure, and the aircraft present position on the active leg.

Geodetic – Set of reference points used to locate places on the earth.

Geodesic – A generalization of the notion of a straight line to curved spaces. The shortest route between two points on the Earth's surface.

Geoid – Global mean sea level.

G-Force and Fast/Slow Indicator – Indications to show the G-force on the aircraft or, for aircraft equipped with a compatible angle of attack computer, the deviation from the reference speed while in the landing configuration.

Glideslope Sidelobes – False glideslope signals.

GPS WAAS Course Deviation Indicator (CDI) – Display of CDI relative to selected course, either automatic based on active flight plan or manual based on pilot-selected OBS.

GPS WAAS Functions – The EFIS meets the GPS WAAS navigation and flight planning/management requirements of TSO-C146a (RTCA/DO-229D) for Class Gamma 3 equipment. These functions include navigation, flight planning (function select, flight plan generation and editing, selected waypoints, user waypoints, etc.), path definition including approach and departure paths, GPS altitude, dead reckoning, navigation modes with automatic mode switching, loss of navigation monitoring, loss of integrity monitoring, etc. The database used with the GPS WAAS functions meets the integrity requirements of RTCA/DO-200A.

Heading Bug – Display and control of selected heading using a bug. May be used to drive heading bug output to autopilot for HSI-based heading mode.

Heading Display – Display of heading with directional scale is provided at the top of the PFD. This is the same heading information provided on the MFD.

Heading Mode Signal Output – Conventional autopilot heading mode signal is a heading error output based on the difference between the EFIS desired heading and the actual aircraft heading. The EFIS desired heading is either the pilot-selected heading bug or a heading designed to achieve and maintain the active GPS-based flight plan.

Hectopascal (hPa) – International System of Units (SI) unit measure of pressure, equals one millibar (mbar).

Horizontal Situation Indicator (Selectable Function) – Display of VOR or localizer and glideslope deviation when selected for display on the PFD.

HOTAS – Hands On Throttle And Stick

Inches of Mercury (inHg) – Unit of atmospheric pressure used in the United States. Named for the use of mercurial barometers which equate height of a column of mercury with air pressure.



Inhibit – Prevention of activity or occurrence. Examples are:

XFILL INHBT and **TAWS INHBT**.

Integrated Peripherals – Internal devices of the essential unit.

Ionosphere – Region of the atmosphere between the stratosphere and exosphere, 50 to 250 miles (80 to 400 km) above the surface of the earth.

International Standard Atmosphere (ISA) – Standard model of the change of pressure, temperature, density, and viscosity over a wide range of altitudes or elevations.

Landing Gear Indication – When enabled on retractable landing gear aircraft, PFD shows indication of landing gear extended.

Lubber Line – Line marked on the compass showing the direction straight ahead.

Mach Display – Display of Mach number when the aircraft is traveling at or above 0.35 Mach. This function may be deselected by a setting in the IDU configuration (limits) file.

Magnetic Declination (MAGVAR) – Sometimes called magnetic variation; the angle between magnetic north and true north.

Map Data – Display of map data, including airspace, VFR/IFR airports, VHF nav aids such as VOR/NDB/DME, jet/victor airways, and display range rings.

Menu Functions – The EFIS includes menus to access functions on both the PFD and the MFD.

Mesocyclonic – Contains a vortex of air within a convective; air rises and rotates around a vertical axis, often in the same direction as low pressure systems.

Millibar (mbar) – Metric (not SI) unit of pressure, one thousandth of a bar, which is about equal to the atmospheric pressure on Earth at sea level - 1013 millibars.



Miscompare – Disparity of data or information. Examples are:

ALT MISCOMP	ATT MISCOMP	GPS MISCOMP
GS MISCOMP	HDG MISCOMP	IAS MISCOMP
LOC MISCOMP	PLT MISCOMP	RALT MISCOMP
	CPLT MISCOMP	and BARO MISCOMP

NavData® – Jeppesen's aeronautical database to navigate the global airspace system.

Navigation Data Display – Display of active waypoint, bearing to waypoint, and ground track based on active flight plan. The pilot may also select flight plan information as a mini map (thumbnail map).

These functions are analyzed as part of the GPS WAAS functions not the PFD functions.

Navigation Log – Display of navigation information based on active flight plan, including next waypoint, destination, estimated time remaining, and fuel totalizer-based range and endurance. This function may be deselected by a setting in the IDU configuration (limits) file. These functions are analyzed as part of the GPS WAAS functions not the MFD functions.

Navigation Mode Signal Output – Conventional autopilot Navigation mode signals are the course error output and the left-right deviation signals. Course error output is based on the difference between the EFIS selected course (OBS) and the actual aircraft heading. These signals are based on the selected navigation signal (VOR, GPS).

Nondirectional – Functions in all directions.

Noodle – Navigation Display (ND) projected path; curving path based upon the aircraft bank angle and groundspeed used effectively to assist in course interception and making small adjustments to bank angle for proper roll out.

Nanoteslas (nT) – A unit of measurement of the strength of the magnetic field. Earth's strongest magnetic field is located at the poles, and the weakest field is near the equator.

Obstructions Display – Display of obstructions identified in the embedded obstruction database which are within 8.5 NM of the aircraft present position. Non-threatening obstructions are displayed by color to identify altitude relative to the aircraft's current altitude (amber [yellow] < 2000' below, light red < 500' below, bright red = at or above aircraft). Threatening obstructions, defined as those that pierce the TAWS envelope, are identified by highlight when producing a caution and identified by flashing highlight when producing a warning. The database used with the obstruction functions meets the integrity requirements of RTCA/DO-200A.

Omnibearing – Magnetic bearing of an omni-range station.

Offset – When referring to parallel track of an active flight plan, "offset" implies the distance paralleling the original track. When referring to VNAV altitudes, "offset" refers to the distance before or after the waypoint the VNAV altitude must be reached.

Ownship – Principal eye-point; referring to icon of aircraft represented on display.

Pitch Limit Indicator – Appears when the aircraft is within 10 knots of stall speed, based on the VSI setting in the EFIS limits. The intent is to notify the pilot of a possible stall condition so corrective action is taken before the stall occurs. This function may be deselected by a setting in the IDU configuration (limits) file.

Q-Routes – Published RNAV routes, including Q-Routes and T-Routes, can be flight planned for use by the Genesys EFIS, subject to any limitations or requirements noted on enroute charts, in applicable advisory circulars, or by NOTAM. RNAV routes are depicted in blue on aeronautical charts and are identified by the letter “Q” or “T” followed by the airway number, e.g., Q35, T-205. Published RNAV routes are RNAV-2 except when specifically charted as RNAV-1.

QFE – Barometric setting that results in the altimeter displaying height above a reference elevation (e.g., airport or runway threshold).

QNE – Standard barometric setting (29.92 inHg or 1013 mbar) used to display pressure attitude for flight above the transition attitude.

QNH – Barometric setting that results in the altimeter displaying altitude above mean sea level at the reporting station.

Recency – State of occurrence, appearance, or origin.

Selection and Display of Selected Course – Omni-Bearing Select (OBS) function for the pilot to select the course for navigation. Selected course is displayed for reference.

Settable V-Speeds, Targets – The pilot may set certain V-speeds for reference during flight. In addition, the pilot may set certain information at any time for reference during flight, including target airspeed (with corresponding bug) and target altitude (with corresponding bug).

Side in Command – Side of aircraft control responsible for its operation.

Skipped Waypoint – A skipped waypoint is a waypoint associated with a dynamic termination leg with a zero length. These are either:

- 1) An altitude termination leg when current aircraft altitude is above the termination altitude; or
- 2) System-created (i.e., not NavData® specified) intercept to a “Course to a Fix” leg where there is insufficient distance to calculate an intercept heading.

Skyway VNAV/LNAV Guidance (Synthetic Vision) – Display of GPS-based active navigation route, flight plan, procedure, or OBS course in a three-dimensional series of skyway boxes. Also known as Highway in the Sky (HITS).

Slip Indicator – Display of aircraft lateral accelerations via an integral slip/skid indicator function. The slip indicator is a rectangle just below the heading pointer that moves left and right to indicate the lateral acceleration sensed by the AHRS in the same manner as the ball in a mechanical slip indicator.

Strikefinder – Lightning detector system (WX-500) connected to EFIS and enabled through factory program settings.

Suppressed Waypoint – A suppressed waypoint (designated by brackets) is an airport associated with an IFR or VFR approach procedure.

Symbology – Use of symbols.

T-Routes – T-Routes are available for use by GPS or GPS/SBAS equipped aircraft from 1,200 feet above the surface (or in some instances higher) up to but not including 18,000 feet MSL. T-Routes are depicted on enroute low altitude charts and considered to include the same attributes of Low altitude airways in the Genesys Aerosystems EFIS declutter menus.

Talker – IDU providing data to external sensors and generating aural alerts. IDUs depend upon intra-system communications to determine which IDU on a side takes over “talker” responsibilities. Only one talker (transmit enabled) per side, two talkers in a two sided system, and a master talker PFD when considering aircraft limits. Any IDU may become a talker through auto reversionary means in the event of the PFD failing.

Terrain Display (PFD Artificial Horizon) – Conformal display of surrounding terrain presented with the artificial horizon, shown in the correct scale and perspective for the aircraft’s current position and altitude. Includes conformal display of known runway locations, direction, scale, and perspective based on aircraft’s current position and altitude.

Terrain Display and TAWS/HTAWS – Display of terrain, including identification and annunciation of threatening terrain in accordance with Terrain Awareness Warning System (TAWS) requirements. Coloring scheme for SVS-TAWS PFD and MAP has been simplified as follows:

Non-alerting Terrain below aircraft – Olive Shades

Non-alerting terrain above aircraft – Brown Shades

TAWS FLTA Caution Terrain – Amber (Yellow)

TAWS FLTA Warning Terrain – Red

Obstacles Below aircraft – Amber (Yellow)

Obstacles above aircraft – Red

When over water – Deep Blue

Threatening terrain is determined by the requirements of TAWS TSO-C151b (fixed wing) and TSO-C194 HTAWS (rotorcraft). Threatening terrain is shaded amber (yellow) for caution situations or shaded red for warning situations per TSO-C151b and TSO-C194. TAWS cautions and warnings are accompanied by an amber (yellow) or red flag and an aural annunciation. TAWS Class A, TAWS Class B, TAWS Class C, Enhanced HTAWS, or HTAWS functions may be activated in the system prior to installation. The database used with the TAWS functions meets the integrity requirements of RTCA/DO-200A.

Timer Indication – Pilot-selected function for a count-up or count-down timer.

Traffic Display – When integrated with an appropriate traffic system, traffic is shown using standard TCAS symbology showing relative position, altitude, climb/decent, and color. The pilot may also show traffic information by selecting the dedicated traffic display page.

Vertical Speed Display – Display of altitude rate of change (vertical speed or climb rate).

V_{PROC} (Procedure Speed) – The aircraft's normal speed (in airspeed units and configured in EFIS limits) for flying instrument approaches (DPs, IAPs, STARs). This value is used for calculating the turn radius used for instrument procedure legs. This speed is not seen on the airspeed tape and only found in the aircraft speed settings inside the limits.

Warning, Caution, and Advisory Flags – Display of, warning, caution, and advisory indications accompanied by aural indications. The flags are stacked in the lower left corner of the PFD. Warnings are always shown at the top of the flag stack, followed by cautions and then advisories. These flags remain in view for as long as the situation exists.

Waterline – Indication of the aircraft's longitudinal axis or waterline (attitude).

Wide Area Augmentation System (WAAS) – Developed by Federal Aviation Administration to provide accurate positioning part of the Satellite Based Augmentation System (SBAS). Other countries have similar systems: Europe: European Geostationary Overlay System (EGNOS); Japan: MTSAT Satellite-based Augmentation System

(MSAS); India: GPS Aided GEO Augmented Navigation system (GAGAN).

Wind Information – Display of wind direction, wind speed, and cross wind component.

Zulu – Display of Zulu time (based on GPS data).

64-000099-080K

