



2100 Autopilot
Programmer/Computer PN 01304
Software Mod Code L or Later
WAAS Capable
Pilot's Operating Handbook



Page Intentionally Blank

Table of Contents

Sec.		Pg.
1	Overview.....	1-1
1.1	Document Organization.....	1-3
1.2	Purpose.....	1-3
1.3	General Control Theory.....	1-3
1.4	Principal Modes of Operation.....	1-4
1.4.1	Roll Axis Control.....	1-4
1.4.2	Pitch Axis Control.....	1-5
1.4.3	Yaw Axis Control.....	1-5
1.5	Block Diagram.....	1-5
1.6	Display Legend.....	1-5
2	Pre-Flight Procedures.....	2-1
2.1	Power-Up Test.....	2-3
2.2	Pre-Flight Test.....	2-6
3	In-Flight Procedures.....	3-1
3.1	Normal Operating Procedures.....	3-3
3.1.1	Roll Attitude (ROLL) Mode.....	3-3
3.1.2	Heading (HDG) Mode.....	3-4
3.1.3	Navigation (NAV) Mode.....	3-5
3.1.3.1	Pilot Selectable Intercept Angle.....	3-6
3.1.4	Global Positioning System Steering (GPSS) Mode.....	3-6
3.1.5	Control Wheel Steering (CWS) Mode.....	3-7
3.1.6	Pitch Attitude (PITCH) Mode.....	3-8
3.1.7	Indicated Airspeed (IAS) Mode.....	3-8
3.1.8	Vertical Speed (VS) Mode.....	3-10

3.1.9	Altitude Hold (ALT) Mode.....	3-11
3.1.10	Altitude Pre-Select Function.....	3-12
3.1.11	Automatic Trim Annunciations.....	3-14
3.1.12	Manual Trim Annunciations.....	3-14
3.1.13	Manual Electric Trim.....	3-15
3.2	Precision Approach Procedures.....	3-16
3.2.1	Straight-In ILS Approach.....	3-16
3.2.2	ILS Approach with Procedure Turn.....	3-18
3.3	Non-Precision Approach Procedures.....	3-18
3.3.1	Straight-In Back Course Approach.....	3-18
3.3.2	Back Course Approach with Procedure Turn.....	3-20
3.3.3	Straight-In LOC Approach.....	3-23
3.3.4	Straight-In VOR Approach.....	3-25
3.3.5	LOC Approach with Procedure Turn.....	3-27
3.3.6	VOR Approach with Procedure Turn.....	3-30
3.3.7	GPSS T Approach.....	3-33
3.3.8	WAAS Procedures.....	3-35
3.4	Yaw Damper (YD) Mode.....	3-37
3.5	Flight Director (FD) Operation.....	3-38
3.5.1	AP and FD Modes Engaged.....	3-38
3.5.2	FD Mode Engaged and AP Mode Disengaged.....	3-38
3.6	Go-Around (GA) Switch.....	3-39
3.7	Menu (MNU) Switch.....	3-39
3.8	Automatic Trim Disable.....	3-40
3.9	Autopilot Disconnect	3-40

4	Operating Parameters.....	4-1
4.1	Roll Axis Limits.....	4-3
4.2	Pitch Axis Limits.....	4-3
4.3	Yaw Axis Limits.....	4-3
5	Glossary.....	5-1

List of Figures

Fig.		Pg.
1-1	2100 Block Diagram.....	1-6
1-2	2100 Programmer/Computer Legend.....	1-7
2-1	AP Display, Self Test In Progress.....	2-4
2-2	AP Display, INITIAL ADAHRS ALIGNMENT.....	2-4
2-3	AP Display, AP READY.....	2-4
2-4	AP Display, AP FAIL.....	2-5
2-5	AP Display, ADAHRS Failure.....	2-5
2-6	AP Display, ROLL and PITCH Modes Engaged (Pre-Flight).....	2-8
2-7	AP Display, HDG and PITCH Modes Engaged (Pre-Flight).....	2-8
2-8	AP Display, HDG and IAS Modes Engaged (Pre-Flight).....	2-8
2-9	AP Display, HDG and VS Modes Engaged (Pre-Flight).....	2-10
2-10	AP Display, HDG and ALT HOLD Modes Engaged (Pre-Flight).....	2-10
2-11	AP Display, CWS Mode Engaged (Pre-Flight).....	2-10
2-12	AP Display, AUTO TRIM DN in Progress (Pre-Flight).....	2-13
2-13	AP Display, AUTO TRIM UP in Progress (Pre-Flight).....	2-13
2-14	AP Display, MANUAL ELECTRIC TRIM in Progress (Pre-Flight).....	2-16

S-TEC

3-1	AP Display, ROLL and PITCH Modes Engaged.....	3-3
3-2	AP Display, HDG and PITCH Modes Engaged.....	3-4
3-3	AP Display, NAV and ALT HOLD Modes Engaged.....	3-5
3-4	AP Display, HDG and ALT HOLD Modes Engaged, NAV Mode Armed	3-6
3-5	AP Display, GPSS and PITCH Modes Engaged.....	3-6
3-6	AP Display, CWS Mode Engaged.....	3-7
3-7	AP Display, ROLL and PITCH Modes Engaged.....	3-8
3-8	AP Display, ROLL and IAS Modes Engaged.....	3-9
3-9	AP Display, ROLL and VS Modes Engaged.....	3-10
3-10	AP Display, ROLL and ALT HOLD Modes Engaged.....	3-11
3-11	AP Display, ROLL and PITCH Modes Engaged, ALT HOLD Mode Armed.....	3-13
3-12	AP Display, ROLL and VS Modes Engaged, ALT HOLD Mode Armed.....	3-13
3-13	AP Display, ROLL and ALT HOLD CAP Modes Engaged.....	3-13
3-14	AP Display, ROLL and ALT HOLD Modes Engaged.....	3-13
3-15	AP Display, AUTO TRIM UP in Progress.....	3-14
3-16	AP Display, AUTO TRIM DN in Progress.....	3-14
3-17	AP Display, MANUAL ELECTRIC TRIM in Progress.....	3-15
3-18	AP Display, APR LOC and ALT HOLD Modes Engaged, GS Mode Armed	3-17
3-19	AP Display, APR LOC and GS CAP Modes Engaged.....	3-17
3-20	AP Display, APR LOC and GS Modes Engaged.....	3-17
3-21	Straight-In ILS Approach.....	3-17
3-22	AP Display, REV Mode Engaged, Track LOC Back Course Inbound...3-19	
3-23	Straight-In Back Course Approach.....	3-19
3-24	AP Display, APR LOC Mode Engaged, Track LOC Back Course Outbound.....	3-20
3-25	AP Display, HDG Mode Engaged, A/C on Procedure Turn.....	3-21
3-26	AP Display, HDG Mode Engaged, REV Mode Armed.....	3-21

3-27	AP Display, REV Mode Engaged, Track LOC Back Course Inbound...	3-21
3-28	Back Course Approach with Procedure Turn.....	3-32
3-29	AP Display, APR LOC Mode Engaged, Track LOC Front Course Inbound.....	3-23
3-30	Straight-In LOC Approach.....	3-24
3-31	AP Display, APR Mode Engaged, Track VOR Front Course Inbound.....	3-25
3-32	Straight-In VOR Approach.....	3-26
3-33	AP Display, REV Mode Engaged, Track LOC Front Course Outbound.....	3-27
3-34	AP Display, HDG Mode Engaged, A/C on Procedure Turn.....	3-28
3-35	AP Display, HDG Mode Engaged, APR LOC Mode Armed.....	3-28
3-36	AP Display, APR LOC Mode Engaged, Track LOC Front Course Inbound.....	3-28
3-37	LOC Approach with Procedure Turn.....	3-29
3-38	AP Display, REV Mode Engaged, Track VOR Front Course Outbound.....	3-30
3-39	AP Display, HDG Mode Engaged, A/C on Procedure Turn.....	3-31
3-40	AP Display, HDG Mode Engaged, APR Mode Armed.....	3-31
3-41	AP Display, APR Mode Engaged, Track VOR Front Course Inbound...	3-31
3-42	VOR Approach with Procedure Turn.....	3-32
3-43	AP Display, GPSS and PITCH Modes Engaged, T Approach.....	3-33
3-44	GPSS T Approach.....	3-34
3-45	AP Display, APR GPSL and ALT HOLD Modes Engaged, GPSV Mode Armed....	3-36
3-46	AP Display, APR GPSL and GPSV CAP Modes Engaged.....	3-36
3-47	AP Display, APR GPSL and GPSV Modes Engaged.....	3-36
3-48	AP Display, YD Mode Engaged.....	3-37
3-49	AP Display, YD Mode Disengaged.....	3-37
3-50	AP Display, AP and FD Modes Engaged.....	3-38
3-51	AP Display, FD Mode Engaged, AP Mode Disengaged.....	3-38
3-52	MUTED ON Icon.....	3-39
3-53	MUTED OFF Icon.....	3-39

List of Tables

Table	Pg.
2-1 Power-Up Test.....	2-3
2-2 Pre-Flight Test.....	2-6
3-1 Roll Attitude (ROLL) Mode Engagement.....	3-3
3-2 Heading (HDG) Mode Engagement.....	3-4
3-3 Navigation (NAV) Mode Engagement.....	3-5
3-4 Pitch Attitude (PITCH) Mode Engagement.....	3-8
3-5 Indicated Airspeed (IAS) Mode Engagement.....	3-9
3-6 Vertical Speed (VS) Mode Engagement.....	3-10
3-7 Altitude Hold (ALT HOLD) Mode Engagement.....	3-11
3-8 Glideslope (GS) Mode Armed.....	3-16
3-9 Reverse (REV) Mode Engagement, BCRS LOC Approach.....	3-18
3-10 Approach Localizer (APR LOC) Mode Engagement, BCRS.....	3-20
3-11 Approach Localizer (APR LOC) Mode Engagement.....	3-23
3-12 Approach (APR) Mode Engagement.....	3-25
3-13 Reverse (REV) Mode Engagement, LOC Approach.....	3-27
3-14 Reverse (REV) Mode Engagement, VOR Approach.....	3-30

SECTION 1 OVERVIEW

Page Intentionally Blank

1.1 Document Organization

- Section 1 Overview
- Section 2 Pre-Flight Procedures
- Section 3 In-Flight Procedures
- Section 4 Operating Parameters
- Section 5 Glossary

1.2 Purpose

This Pilot's Operating Handbook (POH) provides Pre-Flight and In-Flight operating procedures for the S-TEC 2100 Digital Flight Control System (DFCS), hereafter also referred to as autopilot (AP).

Note:

This POH must be carried in the A/C and made available to the pilot at all times. It can only be used in conjunction with the Federal Aviation Administration (FAA) approved Aircraft Flight Manual (AFM) or Aircraft Flight Manual Supplement (AFMS). Refer to the applicable AFM or AFMS for A/C specific information, such as unique ground tests, limitations, and emergency procedures.

Note:

The 2100 DFCS is a tool provided to pilots, that serves to assist them with cockpit workload management. The ability of the autopilot to provide optimum assistance and performance is directly proportional to the pilot's knowledge of its operating procedures. Therefore, it is highly recommended that the pilot develop a thorough understanding of the autopilot, its modes, and operating procedures in Visual Meteorological Conditions (VMC), prior to using it under Instrument Flight Rules (IFR).

1.3 General Control Theory

The 2100 DFCS is a three-axis attitude based autopilot. It controls the roll, pitch, and yaw axes through selected modes of operation.

When in control of the roll axis, the autopilot senses roll attitude, roll rate, heading error, and course error inputs from the air data, attitude, and heading reference system (ADAHRS), and a course deviation input from the selected navigation receiver.

When in control of the pitch axis, the autopilot senses pitch attitude, pitch rate, pressure altitude, indicated airspeed, vertical speed, and vertical acceleration inputs from the ADAHRS, and a glideslope deviation input from the selected glideslope receiver.

When in control of the yaw axis, the autopilot senses a yaw rate input from the ADAHRS, and a lateral acceleration input from an accelerometer in the yaw damper.

These sensed data provide feedback to the autopilot, which processes them in order to control the aircraft through the use of servos coupled to the control system. The roll servo is coupled to the ailerons, the pitch servo is coupled to the elevator, and the yaw servo is coupled to the rudder.

S-TEC

The autopilot senses an out of trim condition about the pitch axis whenever a sensor in the pitch servo is activated. In response to this, the autopilot drives the trim servo, which is coupled to the trim tabs, in the proper direction until the aircraft is in trim.

The autopilot also includes an altitude pre-select function.

1.4 Principal Modes of Operation

1.4.1 Roll Axis Control

Autopilot (AP) Mode

Used to Engage Roll Servo

Flight Director (FD) Mode

Used to Laterally Drive Steering Command Bars

Roll Attitude (ROLL) Mode

Used to Hold Roll Attitude

Heading (HDG) Mode

Used to Turn onto a Selected Heading and Hold it

Navigation (NAV) Mode

Used to Intercept and Track a VOR Course

Approach (APR) Mode

Used to Intercept and Track a LOC Front Course Inbound

Reverse (REV) Mode

Used to Intercept and Track a LOC Back Course Inbound

Control Wheel Steering (CWS) Mode

Used to Capture and Hold new Roll Attitude, Pitch Attitude, Indicated Airspeed, Vertical Speed, or Altitude

Global Positioning System Steering (GPSS) Mode

Used to Laterally Steer along a Course defined by GPS

Global Positioning System Lateral Navigation (GPSL)

Used to Laterally Steer along an Approach Course defined by GPS WAAS

1.4.2 Pitch Axis Control

Autopilot (AP) Mode

Used to Engage Pitch Servo

Flight Director (FD) Mode

Used to Vertically Drive Steering Command Bars

Pitch Attitude (PITCH) Mode

Used to Hold Pitch Attitude

Indicated Airspeed (IAS) Mode

Used to Hold Indicated Airspeed

Vertical Speed (VS) Mode

Used to Hold Vertical Speed

Altitude Hold (ALT HOLD) Mode

Used to Hold Altitude

Glideslope (GS) Mode

Used to Intercept and Track Glideslope

Global Positioning System Vertical Navigation (GPSV)

Used to Vertically Steer along a Glidepath defined by GPS WAAS

Automatic Trim Mode

Used to Automatically Trim about Pitch Axis

1.4.3 Yaw Axis Control

Yaw Damper (YD) Mode

Used to Dampen Excessive Adverse Yaw

1.5 Block Diagram

The 2100 Block Diagram is shown in Fig. 1-1.

1.6 Display Legend

The 2100 Programmer/Computer Legend is shown in Fig. 1-2.

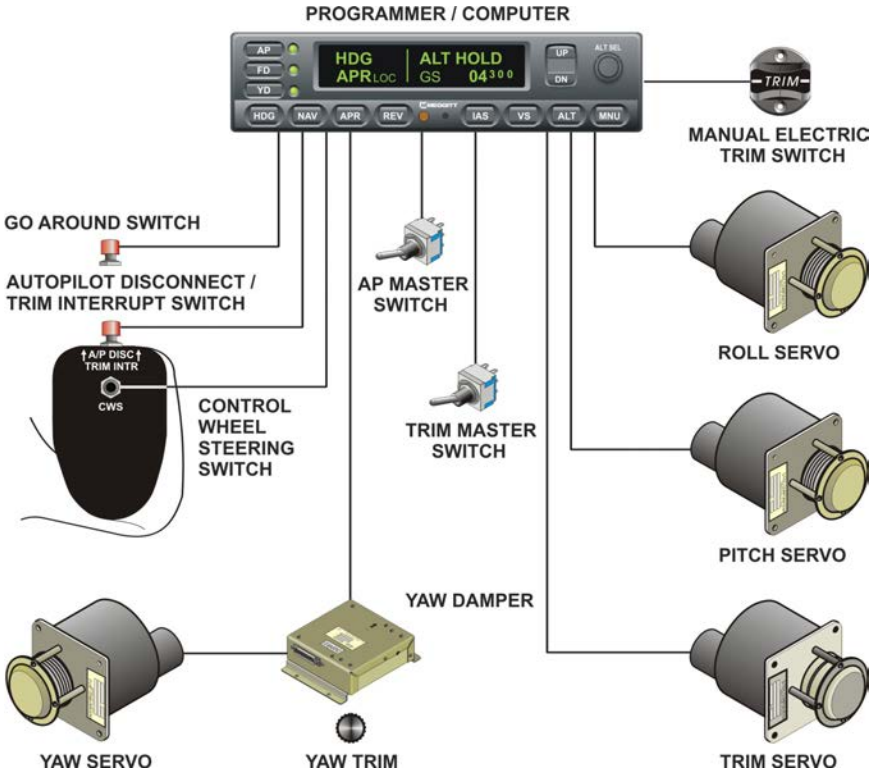

Fig. 1-1. 2100 Block Diagram



1. Autopilot (AP) Mode Selector Switch
2. Flight Director (FD) Mode Selector Switch
3. Yaw Damper (YD) Mode Selector Switch
4. Heading (HDG) Mode Selector Switch
5. Navigation (NAV) Mode Selector Switch
6. Approach (APR) Mode Selector Switch
7. Reverse (REV) Mode Selector Switch
8. Ambient Light Sensor
9. Indicated Airspeed (IAS) Mode Selector Switch
10. Vertical Speed (VS) Mode Selector Switch
11. Altitude Hold (ALT HOLD) Mode Selector Switch
12. Menu (MNU) Mode Selector Switch
13. Altitude Selector (ALT SEL) Knobs
14. Up/Down (UP/DN) Modifier Switches
15. Altitude Selector/Alerter Annunciation
16. Active Pitch Mode Annunciation
17. Armed Pitch Mode Annunciation
18. Active Roll Mode Annunciation
19. Armed Roll Mode Annunciation
20. Light Emitting Diodes (LEDs)

Fig. 1-2. 2100 Programmer/Computer Legend

Page Intentionally Blank

SECTION 2 PRE-FLIGHT PROCEDURES

Page Intentionally Blank

2.1 Power-Up Test

Perform the actions shown in Table 2-1. For each action, verify the corresponding response where applicable.

Table 2-1. Power-Up Test

ACTION	RESPONSE
1. Set Trim Master Switch to OFF position.	-----
2. Set Battery Master Switch to ON position.	-----
3. Set Avionics Master Switch to ON position.	-----
4. Set AP Master Switch to ON position.	<p>The following occur in sequence:</p> <p>Self Test In Progress annunciation appears on AP display as shown in Fig. 2-1, during AP self test.</p> <p>ATTITUDE FAIL annunciation appears on AP display as shown in Fig. 2-2, during initial ADAHRS alignment.</p> <p>AP READY annunciation appears on AP display as shown in Fig. 2-3, to indicate that AP is ready for operation (Note).</p>

Note:

Should an AP failure be detected, the AP FAIL annunciation will appear on the AP display as shown in Fig. 2-4. However, should an ADAHRS failure be detected instead, the ATTITUDE FAIL annunciation will remain on the AP display indefinitely as shown in Fig. 2-5. In either event, the autopilot will not operate. If this occurs, recycle power. Contact your local S-TEC dealer should the condition persist.

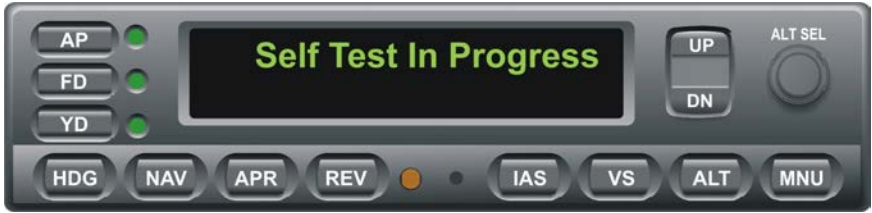

Fig. 2-1. AP Display, Self Test In Progress



Fig. 2-2. AP Display, INITIAL ADAHRS ALIGNMENT



Fig. 2-3. AP Display, AP READY



Fig. 2-4. AP Display, AP FAIL



Fig. 2-5. AP Display, ADAHRS Failure

2.2 Pre-Flight Test

Prior to takeoff and with engine running, perform the actions shown in Table 2-2. For each action, verify the corresponding response where applicable.

Table 2-2. Pre-Flight Test (continued on page 2-7)

ACTION	RESPONSE
1. Move A/C Control Wheel left and right, to sense its freedom of movement about roll axis.	-----
2. Move A/C Control Wheel forward and aft, to sense its freedom of movement about pitch axis.	-----
3. Actuate A/C Rudder Pedals alternately in succession, to sense their freedom of movement about yaw axis.	-----
4. Press AP mode selector switch, to engage roll attitude, pitch attitude, flight director, and yaw damper modes.	AP, FD, and YD LEDs illuminate, while ROLL and PITCH annunciations appear on AP display, as shown in Fig. 2-6.
5. Attempt movement of A/C Control Wheel left and right.	A/C Control Wheel's reduced freedom of movement indicates that Roll Servo is engaged. Roll Servo can be overridden. If not, disconnect autopilot and do not use.
6. Attempt movement of A/C Control Wheel forward and aft.	A/C Control Wheel's reduced freedom of movement indicates that Pitch Servo is engaged. Pitch Servo can be overridden. If not, disconnect autopilot and do not use.

Table 2-2. Pre-Flight Test (continued from page 2-6)

ACTION	RESPONSE
7. Attempt actuation of A/C Rudder Pedals, alternately in succession.	A/C Rudder Pedals' reduced freedom of movement indicates that Yaw Servo is engaged. Yaw Servo can be overridden. If not, disconnect autopilot and do not use.
8. Set Heading Bug under Lubber Line.	-----
9. Press HDG mode selector switch to engage heading mode.	HDG annunciation replaces ROLL on AP display, as shown in Fig. 2-7.
10. Turn Heading Bug to the left side of Lubber Line.	A/C Control Wheel turns to the left.
11. Turn Heading Bug to the right side of Lubber Line.	A/C Control Wheel turns to the right.
12. Set Heading Bug under Lubber Line.	A/C Control Wheel stops.
13. Press IAS mode selector switch to engage indicated airspeed mode.	IAS annunciation replaces PITCH on AP display, and number 100 appears to indicate lowest airspeed allowed in KTS, as shown in Fig. 2-8.
14. Press/Hold UP Modifier Switch.	Airspeed indication increases on AP display.
15. Press/Hold DN Modifier Switch.	Airspeed indication decreases on AP display.



Fig. 2-6. AP Display, ROLL and PITCH Modes Engaged (Pre-Flight)



Fig. 2-7. AP Display, HDG and PITCH Modes Engaged (Pre-Flight)



Fig. 2-8. AP Display, HDG and IAS Modes Engaged (Pre-Flight)

Table 2-2. Pre-Flight Test (continued from page 2-7)

ACTION	RESPONSE
16. Press VS mode selector switch to engage vertical speed mode.	VS annunciation replaces IAS on AP display, and number 0 appears to indicate current vertical speed in FPM, as shown in Fig. 2-9.
17. Press/Hold UP Modifier Switch until a commanded vertical speed of ↑500 (500 FPM climbing) is reached.	A/C Control Wheel moves aft – pilot may have to assist a heavy yoke.
18. Press/Hold DN Modifier Switch until a commanded vertical speed of ↓500 (500 FPM descending) is reached.	A/C Control Wheel moves forward.
19. Press ALT mode selector switch to engage altitude hold mode.	ALT HOLD annunciation replaces VS on AP display, and vertical speed indication is extinguished, as shown in Fig. 2-10.
20. Press/Hold CWS Switch to engage control wheel steering mode.	CWS annunciation appears flashing on AP display as shown in Fig. 2-11, while audible alert sounds a periodic tone.
21. Move A/C Control Wheel left and right.	A/C Control Wheel's increased freedom of movement indicates that Roll Servo is disengaged.
22. Move A/C Control Wheel forward and aft.	A/C Control Wheel's increased freedom of movement indicates that Pitch Servo is disengaged.



Fig. 2-9. AP Display, HDG and VS Modes Engaged (Pre-Flight)



Fig. 2-10. AP Display, HDG and ALT HOLD Modes Engaged (Pre-Flight)



Fig. 2-11. AP Display, CWS Mode Engaged (Pre-Flight)

Table 2-2. Pre-Flight Test (continued from page 2-9)

ACTION	RESPONSE
23. Release CWS Switch to disengage control wheel steering mode.	CWS annunciation is extinguished on AP display.
24. Attempt movement of A/C Control Wheel left and right.	A/C Control Wheel's reduced freedom of movement indicates that Roll Servo is engaged.
25. Attempt movement of A/C Control Wheel forward and aft.	A/C Control Wheel's reduced freedom of movement indicates that Pitch Servo is engaged.
26. Set Trim Master Switch to ON position.	-----

Table 2-2. Pre-Flight Test (continued from page 2-11)

ACTION	RESPONSE
27. Move A/C Control Wheel as far aft as possible.	<p>After 3 seconds, TRIM ↓ Arrow appears on AP display as shown in Fig. 2-12, and A/C Elevator Trim Wheel runs nose down.</p> <p>After 12 seconds, TRIM ↓ Arrow flashes and verbal alert “Trim in Motion” sounds repeatedly.</p>
28. Move A/C Control Wheel as far forward as possible.	<p>After 3 seconds, TRIM ↑ Arrow appears on AP display as shown in Fig. 2-13, and A/C Elevator Trim Wheel runs nose up.</p> <p>After 12 seconds, TRIM ↑ Arrow flashes and verbal alert “Trim in Motion” sounds repeatedly.</p>
29. Set Trim Master Switch to OFF position.	-----
30. Move A/C Control Wheel as far aft as possible.	<p>After 3 seconds, TRIM ↓ Arrow appears on AP display as shown in Fig. 2-12, and verbal alert “Check Pitch Trim” sounds once.</p> <p>After 12 seconds, TRIM ↓ Arrow flashes.</p>
31. Move A/C Control Wheel as far forward as possible.	<p>After 3 seconds, TRIM ↑ Arrow appears on AP display as shown in Fig. 2-13, and verbal alert “Check Pitch Trim” sounds once.</p> <p>After 12 seconds, TRIM ↑ Arrow flashes.</p>



Fig. 2-12. AP Display, AUTO TRIM DN in Progress (Pre-Flight)



Fig. 2-13. AP Display, AUTO TRIM UP in Progress (Pre-Flight)

Table 2-2. Pre-Flight Test (continued from page 2-12)

ACTION	RESPONSE
32. Move A/C Control Wheel aft until TRIM ↑ Arrow is extinguished.	-----
33. Turn Yaw Trim Knob fully CCW.	Left A/C Rudder Pedal slowly moves forward.
34. Turn Yaw Trim Knob fully CW.	Right A/C Rudder Pedal slowly moves forward.
35. Turn Yaw Trim Knob CCW until A/C Rudder Pedals stop.	-----
36. Press AP DISC / TRIM INTR Switch.	<p>AP READY annunciation appears flashing on AP display and audible alert sounds, while all other annunciations and all LEDs are extinguished.</p> <p>AP READY annunciation stops flashing on AP display but remains, and verbal alert “Autopilot Disconnect” sounds once.</p>
37. Move A/C Control Wheel left and right.	A/C Control Wheel's increased freedom of movement indicates that Roll Servo is disengaged.
38. Move A/C Control Wheel forward and aft.	A/C Control Wheel's increased freedom of movement indicates that Pitch Servo is disengaged.
39. Actuate A/C Rudder Pedals alternately in succession.	A/C Rudder Pedals' increased freedom of movement indicates that Yaw Servo is disengaged.

Table 2-2. Pre-Flight Test (continued from page 2-14)

ACTION	RESPONSE
40. Set Trim Master Switch to ON position.	-----
41. Press both forward and aft on each segment of Manual Electric Trim Switch, independently of the other.	In each case, A/C Elevator Trim Wheel does not run.
42. Press/Hold aft on both segments of Manual Electric Trim Switch.	TRIM annunciation appears flashing on AP display as shown in Fig. 2-14, and A/C Elevator Trim Wheel runs nose up.
43. Press/Hold AP DISC / TRIM INTR Switch.	A/C Elevator Trim Wheel stops.
44. Release AP DISC / TRIM INTR Switch.	A/C Elevator Trim Wheel resumes running nose up.
45. Release Manual Electric Trim Switch.	TRIM annunciation is extinguished on AP display, and A/C Elevator Trim Wheel stops.
46. Press/Hold forward on both segments of Manual Electric Trim Switch.	TRIM annunciation appears flashing on AP display as shown in Fig. 2-14, and A/C Elevator Trim Wheel runs nose down.
47. Press/Hold AP DISC / TRIM INTR Switch.	A/C Elevator Trim Wheel stops.
48. Release AP DISC / TRIM INTR Switch.	A/C Elevator Trim Wheel resumes running nose down.

Table 2-2. Pre-Flight Test (continued from page 2-15)

ACTION	RESPONSE
49. Release Manual Electric Trim Switch.	TRIM annunciation is extinguished on AP display, and A/C Elevator Trim Wheel stops.
50. Press GA Switch.	FD LED illuminates, while ROLL and PITCH annunciations appear on AP display.
51. Trim A/C for takeoff.	-----



Fig. 2-14. AP Display, MANUAL ELECTRIC TRIM in Progress (Pre-Flight)

SECTION 3 IN-FLIGHT PROCEDURES

Page Intentionally Blank

3.1 Normal Operating Procedures

3.1.1 Roll Attitude (ROLL) Mode

From any active condition shown in Table 3-1, the corresponding subsequent event will engage the roll attitude mode. The ROLL annunciation will appear as shown in Fig. 3-1. The autopilot will hold the aircraft at its current (captured) roll attitude.

Table 3-1. Roll Attitude (ROLL) Mode Engagement

Active Condition	Subsequent Event	Result
AP READY	AP Switch Pressed	ROLL Mode Engaged
HDG Mode Engaged	HDG Switch Pressed	ROLL Mode Engaged
NAV Mode Engaged	NAV Switch Pressed	ROLL Mode Engaged
GPSS Mode Engaged	NAV Switch Pressed	ROLL Mode Engaged
REV Mode Engaged	REV Switch Pressed	ROLL Mode Engaged



Fig. 3-1. AP Display, ROLL and PITCH Modes Engaged

3.1.2 Heading (HDG) Mode

Set the Heading Bug to the desired heading on the compass card. From any active condition shown in Table 3-2, the corresponding subsequent event will engage the heading mode. The HDG annunciation will appear as shown in Fig. 3-2. The autopilot will turn the aircraft onto the selected heading and hold it. A new heading can be selected thereafter by setting the Heading Bug to it.

Table 3-2. Heading (HDG) Mode Engagement

Active Condition	Subsequent Event	Result
ROLL Mode Engaged	HDG Switch Pressed	HDG Mode Engaged
NAV Mode Engaged	HDG Switch Pressed	HDG Mode Engaged
GPSS Mode Engaged	HDG Switch Pressed	HDG Mode Engaged
APR Mode Engaged	HDG Switch Pressed	HDG Mode Engaged
APR LOC Mode Engaged	HDG Switch Pressed	HDG Mode Engaged
REV Mode Engaged	HDG Switch Pressed	HDG Mode Engaged



Fig. 3-2. AP Display, HDG and PITCH Modes Engaged

3.1.3 Navigation (NAV) Mode

Select the VOR frequency on the Navigation Receiver. Set the Course Pointer to the desired course on the compass card. From any active condition shown in Table 3-3, the corresponding subsequent event will engage the navigation mode. The NAV annunciation will appear as shown in Fig. 3-3.

When CDI needle deflection is greater than 50% from center, the autopilot will establish the aircraft on a 45° intercept angle relative to the selected course. Even if CDI needle deflection is less than 50%, the autopilot may still establish an intercept angle of 45°, provided that the aircraft's closure rate to the selected course is sufficiently slow. Otherwise, the intercept angle will be less than 45°. An exception to this occurs in the case of a pilot selectable intercept angle (reference section 3.1.3.1). Once the point has been reached at which the autopilot must begin to turn the aircraft onto the course, the course is captured. After completing the turn, the autopilot will establish the crosswind correction angle and track the course.

Table 3-3. Navigation (NAV) Mode Engagement

Active Condition	Subsequent Event	Result
ROLL Mode Engaged	NAV Switch Pressed	NAV Mode Engaged
HDG Mode Engaged, NAV Mode Armed	Course Captured	NAV Mode Engaged
GPSS Mode Engaged	VOR or LOC Selected	NAV Mode Engaged
APR Mode Engaged	NAV Switch Pressed	NAV Mode Engaged
REV Mode Engaged	NAV Switch Pressed	NAV Mode Engaged



Fig. 3-3. AP Display, NAV and ALT HOLD Modes Engaged

Should the NAV Flag appear, the NAV and FAIL annunciators will alternately flash. If this occurs prior to course capture, the autopilot will hold the aircraft's wings level, and not attempt to capture the course. However, if this occurs after course capture, the autopilot will hold the last known crosswind corrected course, and ignore CDI needle deflection.

Once tracking, should CDI needle deflection exceed 50% from center for a period of 15 seconds, the NAV annunciation will flash. If the aircraft subsequently returns to within 50% CDI needle deflection from center, the NAV annunciation will stop flashing but remain.

3.1.3.1 Pilot Selectable Intercept Angle

To select an intercept angle other than 45°, set the Heading Bug to the desired intercept heading on the compass card, such that the difference between this heading and the desired course is the intercept angle. Set the Course Pointer to the desired course. Engage the heading mode, and press the NAV mode selector switch to arm the navigation mode. The HDG and NAV annunciators will appear as shown in Fig. 3-4.

The autopilot will establish the aircraft on the selected intercept angle (heading). The autopilot will hold this heading until the course is captured. At that point in the intercept sequence, the HDG annunciation will extinguish and NAV will move into its place, to indicate engagement of the navigation mode.



Fig. 3-4. AP Display, HDG and ALT HOLD Modes Engaged, NAV Mode Armed

3.1.4 Global Positioning System Steering (GPSS) Mode

Program a valid waypoint or flight plan into the GPS Navigator, and press the NAV mode selector switch. The NAV GPSS annunciation will appear as shown in Fig. 3-5. The autopilot will laterally steer the aircraft along the predefined course. During the GPSS mode of operation, the autopilot will not accept any course error input from the Course Pointer.



Fig. 3-5. AP Display, GPSS and PITCH Modes Engaged

3.1.5 Control Wheel Steering (CWS) Mode

Press and hold the CWS Switch to engage the CWS mode. The CWS annunciation will appear flashing as shown in Fig. 3-6, while an audible alert sounds. In addition, both the roll and pitch servos will disengage. Maneuver the aircraft as desired, and then release the CWS Switch to disengage the CWS mode. The CWS annunciation will extinguish, the audible alert will be squelched, and both servos will re-engage.

The autopilot will resume operation in the previous mode. If the HDG mode was engaged, the autopilot will hold the selected heading. If the NAV, GPSS, APR, or REV mode was engaged, the autopilot will track the selected course. If the IAS, VS, or ALT mode was engaged, the autopilot will hold the new indicated airspeed, vertical speed, or altitude, respectively. If the ROLL or PITCH mode was engaged, the autopilot will hold the new roll attitude or pitch attitude, respectively.



Fig. 3-6. AP Display, CWS Mode Engaged

3.1.6 Pitch Attitude (PITCH) Mode

From any active condition shown in Table 3-4, the corresponding subsequent event will engage the pitch attitude mode. The PITCH annunciation will appear as shown in Fig. 3-7. The autopilot will hold the aircraft at its current (captured) pitch attitude.

The captured pitch attitude may be increased or decreased by pressing the UP or DN Modifier Switch, respectively. A single press of the switch will change the pitch attitude 0.25° . However, pressing and holding the switch will cause the pitch attitude to change at a rate of 1° -per-second.

Table 3-4. Pitch Attitude (PITCH) Mode Engagement

Active Condition	Subsequent Event	Result
AP READY	AP Switch Pressed	PITCH Mode Engaged
AP READY	FD Switch Pressed	PITCH Mode Engaged
IAS Mode Engaged	IAS Switch Pressed	PITCH Mode Engaged
ALT HOLD Mode Engaged	ALT Switch Pressed	PITCH Mode Engaged
GS Mode Engaged	GA Switch Pressed	PITCH Mode Engaged



Fig. 3-7. AP Display, ROLL and PITCH Modes Engaged

3.1.7 Indicated Airspeed (IAS) Mode

From any active condition shown in Table 3-5, the corresponding subsequent event will engage the indicated airspeed mode. The IAS annunciation will appear as shown in Fig. 3-8, along with the current (captured) indicated airspeed. The latter appears as a number in units of KTS (i.e., for example, 105 KTS). The autopilot will hold the aircraft at the captured indicated airspeed.

The captured indicated airspeed may be increased or decreased by pressing the UP or DN Modifier Switch, respectively. A single press of the switch will change the indicated airspeed by 1 KT. However, pressing and holding the switch will cause the indicated airspeed to change at a rate of 20 KTS-per-second.

Table 3-5. Indicated Airspeed (IAS) Mode Engagement

Active Condition	Subsequent Event	Result
PITCH Mode Engaged	IAS Switch Pressed	IAS Mode Engaged
VS Mode Engaged	IAS Switch Pressed	IAS Mode Engaged
ALT CAP Mode Engaged	IAS Switch Pressed	IAS Mode Engaged
ALT HOLD Mode Engaged	IAS Switch Pressed	IAS Mode Engaged
GS Mode Engaged	IAS Switch Pressed	IAS Mode Engaged

Caution:

Engine power and airspeed must be monitored when the IAS mode is engaged, since:

Insufficient power at low airspeeds may cause the aircraft to stall, and the autopilot to disconnect.

Although the autopilot should limit the airspeed to 3-5 knots below the aircraft's maximum operating airspeed V_{mo} , large power changes at higher airspeeds may cause the aircraft to momentarily exceed V_{mo} .



Fig. 3-8. AP Display, ROLL and IAS Modes Engaged

3.1.8 Vertical Speed (VS) Mode

From any active condition shown in Table 3-6, the corresponding subsequent event will engage the vertical speed mode. The VS annunciation will appear as shown in Fig. 3-9, along with the current (captured) vertical speed. The latter appears as a number in units of FPM, prefixed by either an ↑ arrow to indicate a climb, or a ↓ arrow to indicate a descent (i.e., for example, ↑500 indicates 500 FPM climbing). The autopilot will hold the aircraft at the captured vertical speed.

The captured vertical speed may be increased or decreased by pressing the UP or DN Modifier Switch, respectively. A single press of the switch will change the vertical speed by 100 FPM. However, pressing and holding the switch will cause the vertical speed to change at a rate of 400 FPM-per-second.

During a climb, should the commanded vertical speed exceed the actual vertical speed by 300 FPM for a period of 10 seconds, the VS annunciation will flash as an alert to the potential for an impending stall condition. In this event, immediately increase the aircraft's thrust if possible, reduce the commanded vertical speed using the DN Modifier Switch, or both, until the VS annunciation stops flashing.

Table 3-6. Vertical Speed (VS) Mode Engagement

Active Condition	Subsequent Event	Result
PITCH Mode Engaged	VS Switch Pressed	VS Mode Engaged
IAS Mode Engaged	VS Switch Pressed	VS Mode Engaged
ALT CAP Mode Engaged	VS Switch Pressed	VS Mode Engaged
ALT HOLD Mode Engaged	VS Switch Pressed	VS Mode Engaged
GS Mode Engaged	VS Switch Pressed	VS Mode Engaged



Fig. 3-9. AP Display, ROLL and VS Modes Engaged

3.1.9 Altitude Hold (ALT HOLD) Mode

From any active condition shown in Table 3-7, the corresponding subsequent event will engage the altitude hold mode. The ALT HOLD annunciation will appear as shown in Fig. 3-10. Rotating either concentric ALT SEL Rotary Knob a single detent will cause the current (captured) baro-corrected altitude to also appear, as a number in units of FT (i.e., for example, 12500 FT). The autopilot will hold the aircraft at the captured altitude.

The captured altitude may be increased or decreased by pressing the UP or DN Modifier Switch, respectively. A single press of the switch will change the altitude by 20 FT, and the range is ± 500 FT from the original captured altitude. However, pressing and holding the switch will cause the altitude to change at a rate of 40 FT-per-second.

Table 3-7. Altitude Hold (ALT HOLD) Mode Engagement

Active Condition	Subsequent Event	Result
PITCH Mode Engaged	ALT Switch Pressed	ALT HOLD Mode Engaged
IAS Mode Engaged	ALT Switch Pressed	ALT HOLD Mode Engaged
VS Mode Engaged	ALT Switch Pressed	ALT HOLD Mode Engaged
ALT CAP Mode Engaged	ALT Switch Pressed	ALT HOLD Mode Engaged
ALT CAP Mode Engaged	Target Altitude Captured	ALT HOLD Mode Engaged
GS Mode Engaged	ALT Switch Pressed	ALT HOLD Mode Engaged
GS Mode Engaged	APR LOC Mode Disengaged	ALT HOLD Mode Engaged



Fig. 3-10. AP Display, ROLL and ALT HOLD Modes Engaged

3.1.10 Altitude Pre-Select Function

The Altitude Pre-Select Function allows the pilot to pre-select a target altitude, and the vertical speed (if within the aircraft's capabilities) at which the aircraft will climb or descend, until that altitude is captured.

Pre-select the target altitude using the concentric ALT SEL Rotary Knobs. Rotate either knob clockwise (CW) to increase the target altitude, or counter-clockwise (CCW) to decrease the target altitude. Each outer knob detent changes the target altitude by 1000 FT, whereas each inner knob detent changes the target altitude by 100 FT. The target altitude will appear as a number in units of FT, as shown in Fig. 3-11 (i.e., for example, 12500 FT), along with the ALT annunciation to indicate that the ALT HOLD mode is armed. Pressing the inner knob once cancels the target altitude, and displays dashes instead. Pressing the inner knob a second time restores the target altitude. If no target altitude is initially selected as indicated by dashes, then rotating either concentric knob a single detent will cause the current altitude to appear.

Engage the VS mode, and use the UP or DN Modifier Switch to select the desired rate of climb or descent, respectively. The VS annunciation will replace the prior pitch axis mode annunciation, and the selected vertical speed will appear as a number in units of FPM, as shown in Fig. 3-12 (i.e., for example, ↑500 indicates 500 FPM climbing).

When the aircraft arrives at a distance of 1000 FT from the target altitude, an audible alert sounds, followed by the verbal alert "One Thousand to Go". Once the point has been reached at which the autopilot must begin a scheduled reduction in vertical speed, the target altitude is captured. The VS annunciation will be replaced by CAP, as shown in Fig. 3-13, to indicate engagement of the ALT HOLD CAP mode. At 200 FT from altitude, the audible alert sounds again, followed by the verbal alert "Two Hundred to Go". When the aircraft finally reaches altitude, the verbal alert "Altitude" sounds and the ALT HOLD mode engages. The ALT annunciation will extinguish and ALT HOLD will replace CAP, as shown in Fig. 3-14. Should the aircraft happen to subsequently exceed a distance of ± 200 FT from the captured altitude, the audible alert "Check Altitude" will sound.



Fig. 3-11. AP Display, ROLL and PITCH Modes Engaged, ALT HOLD Mode Armed



Fig. 3-12. AP Display, ROLL and VS Modes Engaged, ALT HOLD Mode Armed



Fig. 3-13. AP Display, ROLL and ALT HOLD CAP Modes Engaged



Fig. 3-14. AP Display, ROLL and ALT HOLD Modes Engaged

3.1.11 Automatic Trim Annunciations

When the Trim Master Switch is in the ON position, the autopilot will provide a trim annunciation whenever it is automatically trimming the aircraft. Should the pitch servo loading exceed a preset threshold for a period of 3 seconds, the autopilot will annunciate either a TRIM ↑ Arrow or a TRIM ↓ Arrow, as an advisement that the autopilot is automatically trimming the aircraft in the indicated direction. This is shown in Fig. 3-15 and Fig. 3-16, respectively. If the autopilot is still in the process of automatically trimming the aircraft after 9 more seconds, the trim annunciation will flash, and the verbal alert "Trim in Motion" will sound repeatedly. As soon as the aircraft has been sufficiently trimmed, such that the pitch servo loading is below the preset threshold, the trim annunciation will extinguish and the verbal alert will be squelched.



Fig. 3-15. AP Display, AUTO TRIM UP in Progress



Fig. 3-16. AP Display, AUTO TRIM DN in Progress

3.1.12 Manual Trim Annunciations

When the Trim Master Switch is in the OFF position, the autopilot will provide a trim annunciation whenever it is necessary to manually trim the aircraft using the Elevator Trim Wheel. Should the pitch servo loading exceed a preset threshold for a period of 3 seconds, the autopilot will annunciate either a TRIM ↑ Arrow or a TRIM ↓ Arrow, as shown in Fig. 3-15 or Fig. 3-16, respectively. In addition, the verbal alert "Check Pitch Trim" will sound once. After 9 more seconds, the trim annunciation will flash. As soon as the aircraft has been sufficiently trimmed, such that the pitch servo loading is below the preset threshold, the trim annunciation will extinguish.

3.1.13 Manual Electric Trim

The Manual Electric Trim Switch is located on the Control Wheel. It can only be used to trim the aircraft when the AP Mode is disengaged. Attempting to use it otherwise will disconnect the autopilot. To trim the aircraft nose up, press aft and maintain pressure on both segments of the Manual Electric Trim Switch. To trim the aircraft nose down, press forward and maintain pressure on both segments of the Manual Electric Trim Switch. In either case, the TRIM annunciation will appear flashing as shown in Fig. 3-17.



Fig. 3-17. AP Display, MANUAL ELECTRIC TRIM in Progress

3.2 Precision Approach Procedures

3.2.1 Straight-In ILS Approach

Execute a straight-in intercept and track of the FRONT INBOUND LOC course (reference section 3.3.3), with either the PITCH, IAS, VS, or ALT HOLD mode engaged. From any active condition shown in Table 3-8, the corresponding subsequent event will arm the GS mode. The GS annunciation will appear as shown in Fig. 3-18.

Table 3-8. Glideslope (GS) Mode Armed

Active Condition	Subsequent Event	Result
No Armed Pitch Mode	APR LOC Mode Engaged, CDI < 50%, GDI < 50% Above GS	GS Mode Armed
ALT HOLD Mode Armed	APR LOC Mode Engaged, CDI < 50%, GDI < 50% Above GS	GS Mode Armed

The armed GS mode can be subsequently disarmed by engaging a different roll mode.

With the GS mode armed, once the aircraft arrives within 25% of the GS centerline, either above or below, the glideslope is captured. The active pitch mode annunciation will be replaced by CAP, to indicate engagement of the GS CAP mode, and a vertical speed will be established that is proportional to the indicated airspeed, as shown in Fig. 3-19.

With the GS CAP mode engaged, once the aircraft arrives within 5% of the GS centerline, either above or below, or a period of 10 seconds has elapsed, the GS mode engages. The CAP annunciation will extinguish and GS will move into its place, as shown in Fig. 3-20. This marks the end of the intercept sequence, and the beginning of tracking.

Once tracking, should GDI needle deflection exceed 50% from center, the GS annunciation will flash. Should the GS Flag appear, the GS and FAIL annunciations will alternately flash.

At the Decision Height (DH) or Missed Approach Point (MAP), disconnect the autopilot to execute either a manual landing or go-around, respectively.

A pictorial of this procedure is shown in Fig. 3-21.



Fig. 3-18. AP Display, APR LOC and ALT HOLD Modes Engaged, GS Mode Armed



Fig. 3-19. AP Display, APR LOC and GS CAP Modes Engaged



Fig. 3-20. AP Display, APR LOC and GS Modes Engaged

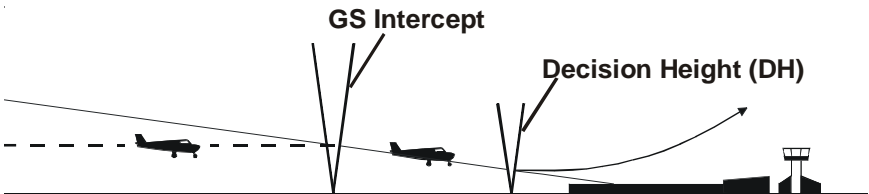

Fig. 3-21. Straight-In ILS Approach

3.2.2 ILS Approach with Procedure Turn

Execute a procedure turn intercept and track of the FRONT INBOUND LOC course (reference section 3.3.5) above the approach altitude, just until the aircraft is established on the FRONT INBOUND PROCEDURE TURN heading, with the HDG mode still engaged. Press the VS mode selector switch to engage the VS mode, and select the desired descent speed using the DN Modifier Switch. Upon reaching the approach altitude, press the ALT mode selector switch to engage the ALT HOLD mode. Press the APR mode selector switch to arm the APR LOC mode, such that the autopilot will execute a straight-in intercept and track of the FRONT INBOUND LOC course (reference section 3.3.3). Execute a straight-in intercept and track of the GS (reference section 3.2.1).

For those aircraft equipped with the Garmin 400W/500W Series GPS Navigator or equivalent unit, with the GPSS mode engaged, the autopilot is capable of executing the entire lateral approach sequence if it has been programmed into the GPS Navigator.

Once on the FRONT INBOUND LOC course, with the GPS Navigator set to VLOC and the GS mode armed, press the APR mode selector switch to engage the APR LOC mode and complete the ILS approach.

3.3 Non-Precision Approach Procedures

3.3.1 Straight-In Back Course Approach

Select the LOC frequency on the Navigation Receiver. Set the Course Pointer to the FRONT INBOUND LOC course on the compass card. From any active condition shown in Table 3-9, the corresponding subsequent event will engage the REV mode. The REV annunciation will appear as shown in Fig. 3-22. The autopilot will intercept and track the BACK INBOUND LOC course. A summary pictorial of this procedure is shown in Fig. 3-23.

Table 3-9. Reverse (REV) Mode Engagement, BCRS LOC Approach

Active Condition	Subsequent Event	Result
ROLL Mode Engaged	REV Switch Pressed	REV Mode Engaged
HDG Mode Engaged, REV Mode Armed	BACK INBOUND LOC Course Captured	REV Mode Engaged
NAV Mode Engaged	REV Switch Pressed	REV Mode Engaged
APR Mode Engaged	REV Switch Pressed	REV Mode Engaged
APR LOC Mode Engaged	REV Switch Pressed	REV Mode Engaged



Fig. 3-22. AP Display, REV Mode Engaged, Track LOC Back Course Inbound

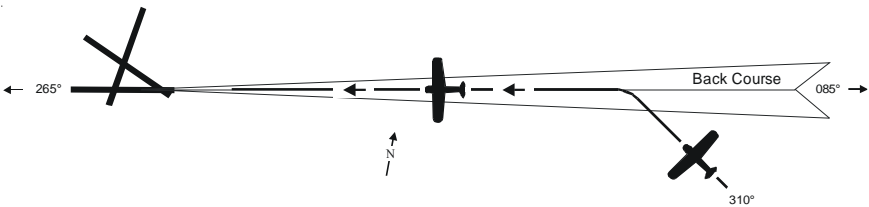

- a. Select LOC frequency.
- b. Set Course Pointer to FRONT INBOUND LOC course.
- c. Either:
 - Press REV mode selector switch to engage REV mode.
 - Or:
 - Set Heading Bug to desired intercept heading.
 - Press HDG mode selector switch to engage HDG mode.
 - Press REV mode selector switch to arm REV mode.
- d. Intercept and track BACK INBOUND LOC course.

Fig. 3-23. Straight-In Back Course Approach

3.3.2 Back Course Approach with Procedure Turn

Select the LOC frequency on the Navigation Receiver. Set the Course Pointer to the FRONT INBOUND LOC course on the compass card. From any active condition shown in Table 3-10, the corresponding subsequent event will engage the APR LOC mode. The APR LOC annunciation will appear as shown in Fig. 3-24. The autopilot will intercept and track the BACK OUTBOUND LOC course.

Table 3-10. Approach Localizer (APR LOC) Mode Engagement, BCRS

Active Condition	Subsequent Event	Result
ROLL Mode Engaged	APR Switch Pressed	APR LOC Mode Engaged
HDG Mode Engaged, APR LOC Mode Armed	LOC Back Course Captured	APR LOC Mode Engaged
NAV Mode Engaged	APR Switch Pressed	APR LOC Mode Engaged
REV Mode Engaged	APR Switch Pressed	APR LOC Mode Engaged



Fig. 3-24. AP Display, APR LOC Mode Engaged, Track LOC Back Course Outbound

At the appropriate time, set the Heading Bug to the BACK OUTBOUND PROCEDURE TURN heading. Press the HDG mode selector switch to engage the heading mode. The HDG annunciation will appear as shown in Fig. 3-25. Hold this heading until the point at which it is time to turn the aircraft again. At that point, turn the Heading Bug in two successive 90° increments, to establish the aircraft on the BACK INBOUND PROCEDURE TURN heading. Press the REV mode selector switch to arm the REV mode. The REV annunciation will appear below the HDG annunciation, as shown in Fig. 3-26. Once the BACK INBOUND LOC course is captured, the HDG annunciation will extinguish and REV will move into its place, as shown in Fig. 3-27. The autopilot will intercept and track the BACK INBOUND LOC course.

A summary pictorial of this procedure is shown in Fig. 3-28.

For those aircraft equipped with the Garmin 400W/500W Series GPS Navigator or equivalent unit, with the GPSS mode engaged, the autopilot is capable of executing this entire lateral approach sequence if it has been programmed into the GPS Navigator.

Once on the BACK INBOUND LOC course, and with the GPS Navigator set to VLOC, press the REV mode selector switch to engage the REV mode and complete the back course approach.



Fig. 3-25. AP Display, HDG Mode Engaged, A/C on Procedure Turn



Fig. 3-26. AP Display, HDG Mode Engaged, REV Mode Armed



Fig. 3-27. AP Display, REV Mode Engaged, Track LOC Back Course Inbound

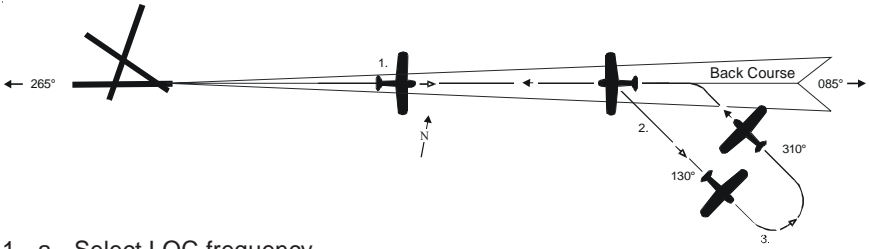

1. a. Select LOC frequency.
- b. Set Course Pointer to FRONT INBOUND LOC course.
- c. Either:
 Press APR mode selector switch to engage APR LOC mode.
 Or:
 Set Heading Bug to desired intercept heading.
 Press HDG mode selector switch to engage HDG mode.
 Press APR mode selector switch to arm APR LOC mode.
- d. Intercept and track BACK OUTBOUND LOC course.
2. a. At appropriate time, set Heading Bug to BACK OUTBOUND PROCEDURE TURN heading.
- b. Press HDG mode selector switch to engage HDG mode.
3. a. Turn Heading Bug in two successive 90° increments, to establish aircraft on BACK INBOUND PROCEDURE TURN heading.
- b. Press REV mode selector switch to arm REV mode.
- c. Intercept and track BACK INBOUND LOC course.

Fig. 3-28. Back Course Approach with Procedure Turn

3.3.3 Straight-In LOC Approach

Select the LOC frequency on the Navigation Receiver. Set the Course Pointer to the FRONT INBOUND LOC course on the compass card. From any active condition shown in Table 3-11, the corresponding subsequent event will engage the APR LOC mode. The APR LOC annunciation will appear as shown in Fig. 3-29. The autopilot will intercept and track the FRONT INBOUND LOC course.

Table 3-11. Approach Localizer (APR LOC) Mode Engagement

Active Condition	Subsequent Event	Result
ROLL Mode Engaged	APR Switch Pressed	APR LOC Mode Engaged
HDG Mode Engaged, APR LOC Mode Armed	LOC Course Captured	APR LOC Mode Engaged
NAV Mode Engaged	APR Switch Pressed	APR LOC Mode Engaged
REV Mode Engaged	APR Switch Pressed	APR LOC Mode Engaged



Fig. 3-29. AP Display, APR LOC Mode Engaged, Track LOC Front Course Inbound

A summary pictorial of this procedure is shown in Fig. 3-30.

S-TEC

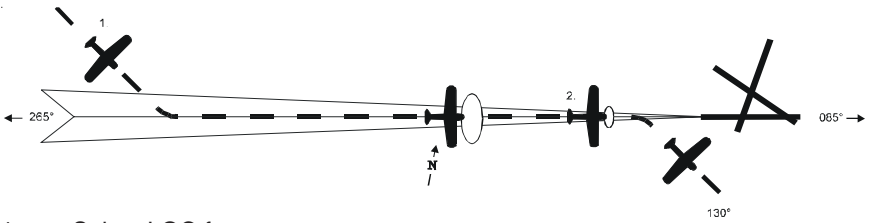

1. a. Select LOC frequency.
b. Set Course Pointer to FRONT INBOUND LOC course.
c. Either:
Press APR mode selector switch to engage APR LOC mode.
Or:
Set Heading Bug to desired intercept heading.
Press HDG mode selector switch to engage HDG mode.
Press APR mode selector switch to arm APR LOC mode.
d. Intercept and track FRONT INBOUND LOC course.
2. a. At middle marker, if missed approach is declared, disconnect autopilot.
b. Stabilize aircraft.
c. Set Heading Bug to missed approach heading.
d. Press HDG mode selector switch to engage HDG mode.

Fig. 3-30. Straight-In LOC Approach

3.3.4 Straight-In VOR Approach

Select the VOR frequency on the Navigation Receiver. Set the Course Pointer to the FRONT INBOUND VOR course on the compass card. From any active condition shown in Table 3-12, the corresponding subsequent event will engage the APR mode. The APR annunciation will appear as shown in Fig. 3-31. The autopilot will intercept and track the FRONT INBOUND VOR course.

Table 3-12. Approach (APR) Mode Engagement

Active Condition	Subsequent Event	Result
ROLL Mode Engaged	APR Switch Pressed	APR Mode Engaged
HDG Mode Engaged, APR Mode Armed	VOR Course Captured	APR Mode Engaged
NAV Mode Engaged	APR Switch Pressed	APR Mode Engaged
REV Mode Engaged	APR Switch Pressed	APR Mode Engaged



Fig. 3-31. AP Display, APR Mode Engaged, Track VOR Front Course Inbound

A summary pictorial of this procedure is shown in Fig. 3-32.

S-TEC

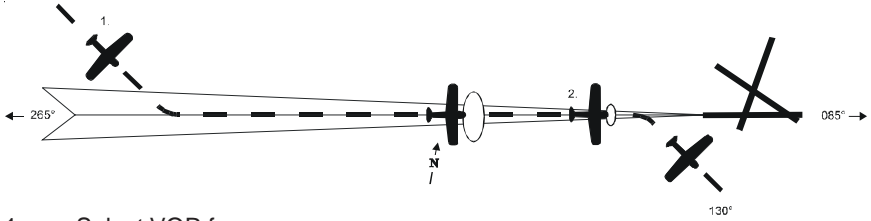

1. a. Select VOR frequency.
b. Set Course Pointer to FRONT INBOUND VOR course.
c. Either:
 Press APR mode selector switch to engage APR mode.
 Or:
 Set Heading Bug to desired intercept heading.
 Press HDG mode selector switch to engage HDG mode.
 Press APR mode selector switch to arm APR mode.
d. Intercept and track FRONT INBOUND VOR course.
2. a. At middle marker, if missed approach is declared, disconnect autopilot.
b. Stabilize aircraft.
c. Set Heading Bug to missed approach heading.
d. Press HDG mode selector switch to engage HDG mode.

Fig. 3-32. Straight-In VOR Approach

3.3.5 LOC Approach with Procedure Turn

Select the LOC frequency on the Navigation Receiver. Set the Course Pointer to the FRONT INBOUND LOC course on the compass card. From any active condition shown in Table 3-13, the corresponding subsequent event will engage the REV mode. The REV annunciation will appear as shown in Fig. 3-33. The autopilot will intercept and track the FRONT OUTBOUND LOC course.

Table 3-13. Reverse (REV) Mode Engagement, LOC Approach

Active Condition	Subsequent Event	Result
ROLL Mode Engaged	REV Switch Pressed	REV Mode Engaged
HDG Mode Engaged, REV Mode Armed	FRONT OUTBOUND LOC Course Captured	REV Mode Engaged
NAV Mode Engaged	REV Switch Pressed	REV Mode Engaged
APR Mode Engaged	REV Switch Pressed	REV Mode Engaged
APR LOC Mode Engaged	REV Switch Pressed	REV Mode Engaged



Fig. 3-33. AP Display, REV Mode Engaged, Track LOC Front Course Outbound

At the appropriate time, set the Heading Bug to the FRONT OUTBOUND PROCEDURE TURN heading. Press the HDG mode selector switch to engage the heading mode. The HDG annunciation will appear as shown in Fig. 3-34. Hold this heading until the point at which it is time to turn the aircraft again. At that point, turn the Heading Bug in two successive 90° increments, to establish the aircraft on the FRONT INBOUND PROCEDURE TURN heading. Press the APR mode selector switch to arm the APR LOC mode. The APR LOC annunciation will appear below the HDG annunciation, as shown in Fig. 3-35. Once the FRONT INBOUND LOC course is captured, the HDG annunciation will extinguish and APR LOC will move into its place, as shown in Fig. 3-36. The autopilot will intercept and track the FRONT INBOUND LOC course.

A summary pictorial of this procedure is shown in Fig. 3-37.

S-TEC

For those aircraft equipped with the Garmin 400W/500W Series GPS Navigator or equivalent unit, with the GPSS mode engaged, the autopilot is capable of executing this entire lateral approach sequence if it has been programmed into the GPS Navigator.

Once on the FRONT INBOUND LOC course, with the GPS Navigator set to VLOC, press the APR mode selector switch to engage the APR LOC mode and complete the intercept.



Fig. 3-34. AP Display, HDG Mode Engaged, A/C on Procedure Turn



Fig. 3-35. AP Display, HDG Mode Engaged, APR LOC Mode Armed



Fig. 3-36. AP Display, APR LOC Mode Engaged, Track LOC Front Course Inbound

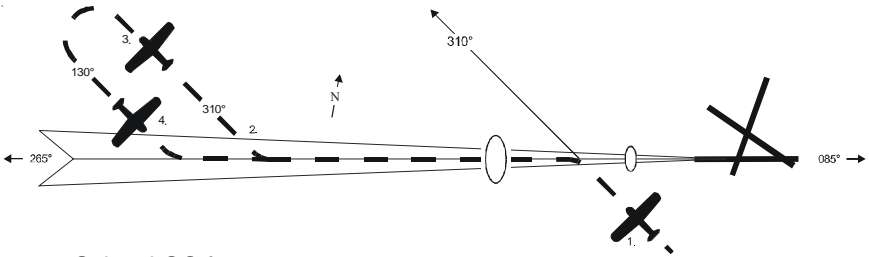

1. a. Select LOC frequency.
 - b. Set Course Pointer to FRONT INBOUND LOC course.
 - c. Either:
 - Press REV mode selector switch to engage REV mode.
 - Or:
 - Set Heading Bug to desired intercept heading.
 - Press HDG mode selector switch to engage HDG mode.
 - Press REV mode selector switch to arm REV mode.
 - d. Intercept and track FRONT OUTBOUND LOC course.
2. a. At appropriate time, set Heading Bug to FRONT OUTBOUND PROCEDURE TURN heading.
 - b. Press HDG mode selector switch to engage HDG mode.
3. a. Turn Heading Bug in two successive 90° increments, to establish aircraft on FRONT INBOUND PROCEDURE TURN heading.
4. a. Press APR mode selector switch to arm APR LOC mode.
 - b. Intercept and track FRONT INBOUND LOC course.
 - c. At middle marker, if missed approach is declared, disconnect autopilot.
 - d. Stabilize aircraft.
 - e. Set Heading Bug to missed approach heading.
 - f. Press HDG mode selector switch to engage HDG mode.

Fig. 3-37. LOC Approach with Procedure Turn

3.3.6 VOR Approach with Procedure Turn

Select the VOR frequency on the Navigation Receiver. Set the Course Pointer to the FRONT INBOUND VOR course on the compass card. From any active condition shown in Table 3-14, the corresponding subsequent event will engage the REV mode. The REV annunciation will appear as shown in Fig. 3-38. The autopilot will intercept and track the FRONT OUTBOUND VOR course.

Table 3-14. Reverse (REV) Mode Engagement, VOR Approach

Active Condition	Subsequent Event	Result
ROLL Mode Engaged	REV Switch Pressed	REV Mode Engaged
HDG Mode Engaged, REV Mode Armed	FRONT OUTBOUND VOR Course Captured	REV Mode Engaged
NAV Mode Engaged	REV Switch Pressed	REV Mode Engaged
APR Mode Engaged	REV Switch Pressed	REV Mode Engaged



Fig. 3-38. AP Display, REV Mode Engaged, Track VOR Front Course Outbound

At the appropriate time, set the Heading Bug to the FRONT OUTBOUND PROCEDURE TURN heading. Press the HDG mode selector switch to engage the heading mode. The HDG annunciation will appear as shown in Fig. 3-39. Hold this heading until the point at which it is time to turn the aircraft again. At that point, turn the Heading Bug in two successive 90° increments, to establish the aircraft on the FRONT INBOUND PROCEDURE TURN heading. Press the APR mode selector switch to arm the APR mode. The APR annunciation will appear below the HDG annunciation, as shown in Fig. 3-40. Once the FRONT INBOUND VOR course is captured, the HDG annunciation will extinguish and APR will move into its place, as shown in Fig. 3-41. The autopilot will intercept and track the FRONT INBOUND VOR course.

A summary pictorial of this procedure is shown in Fig. 3-42.

For those aircraft equipped with the Garmin 400W/500W Series GPS Navigator or equivalent unit, with the GPSS mode engaged, the autopilot is capable of executing this entire lateral approach sequence if it has been programmed into the GPS Navigator.

Once on the FRONT INBOUND VOR course, with the GPS Navigator set to VLOC, press the APR mode selector switch to engage the APR LOC mode and complete the front course approach.



Fig. 3-39. AP Display, HDG Mode Engaged, A/C on Procedure Turn



Fig. 3-40. AP Display, HDG Mode Engaged, APR Mode Armed



Fig. 3-41. AP Display, APR Mode Engaged, Track VOR Front Course Inbound

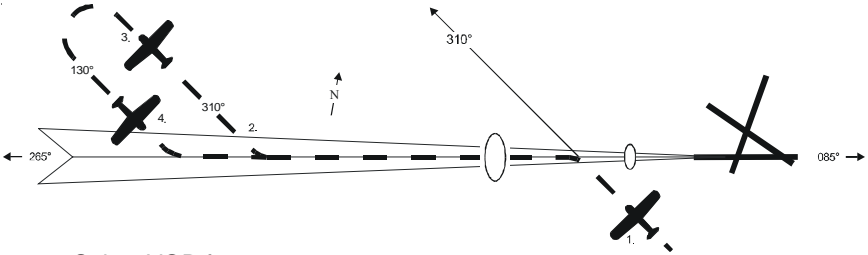

1. a. Select VOR frequency.
 - b. Set Course Pointer to FRONT INBOUND VOR course.
 - c. Either:
 - Press REV mode selector switch to engage REV mode.
 - Or:
 - Set Heading Bug to desired intercept heading.
 - Press HDG mode selector switch to engage HDG mode.
 - Press REV mode selector switch to arm REV mode.
 - d. Intercept and track FRONT OUTBOUND VOR course.
2. a. At appropriate time, set Heading Bug to FRONT OUTBOUND PROCEDURE TURN heading.
 - b. Press HDG mode selector switch to engage HDG mode.
3. a. Turn Heading Bug in two successive 90° increments, to establish aircraft on FRONT INBOUND PROCEDURE TURN heading.
4. a. Press APR mode selector switch to arm APR mode.
 - b. Intercept and track FRONT INBOUND VOR course.
 - c. At middle marker, if missed approach is declared, disconnect autopilot.
 - d. Stabilize aircraft.
 - e. Set Heading Bug to missed approach heading.
 - f. Press HDG mode selector switch to engage HDG mode.

Fig. 3-42. VOR Approach with Procedure Turn

3.3.7 Global Positioning System Steering (GPSS) T Approach

Program the approach into the GPS Navigator, and press the APR mode selector switch. The APR GPSS annunciation will appear as shown in Fig. 3-43. The autopilot will laterally steer the aircraft along the predefined approach, toward the IAF and FAF, making the required turn between them. Begin the descent at the IAF in either the VS or IAS mode. During the GPSS mode of operation, the autopilot will not accept any course error input from the Course Pointer.



Fig. 3-43. AP Display, GPSS and PITCH Modes Engaged, T Approach

A summary pictorial of this procedure is shown in Fig. 3-44.

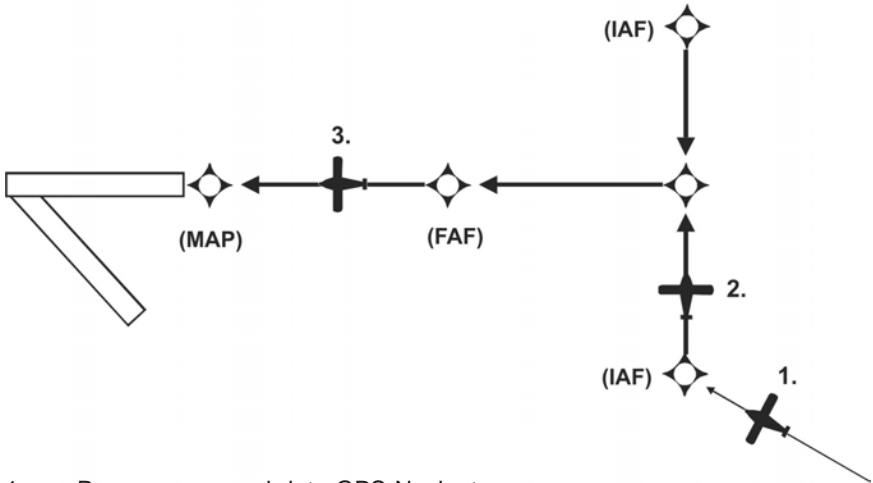

1. a. Program approach into GPS Navigator.
 b. Press APR mode selector switch to engage GPSS mode.
 c. Steer along predefined approach.
 d. Begin descent at IAF in VS or IAS mode.
2. a. Prepare for turn toward FAF.
3. a. At MAP, if missed approach is declared, disconnect autopilot.
 b. Stabilize aircraft.
 c. Set Heading Bug to missed approach heading.
 f. Press HDG mode selector switch to engage HDG mode.

Fig. 3-44. GPSS T Approach

3.3.8 Wide Area Augmentation System (WAAS) Procedures

3.3.8.1 GPS Approach (With Vertical Guidance)

For those aircraft equipped with the Garmin 400W/500W Series GPS Navigator or equivalent unit, the autopilot is capable of executing the entire lateral and vertical approach sequence.

With either the PITCH, IAS, VS, or ALT HOLD mode engaged, select the appropriate WAAS approach on the GPS Navigator from the following possibilities:

1. LPV
2. LNAV/VNAV
3. LNAV+V

Press the APR mode selector switch to engage the APR GPSL mode. Once the following conditions have been satisfied, the GPSV mode will become armed:

1. CDI < 50%
2. GDI < 50% Above Glidepath

The APR GPSL and GPSV annunciations will appear as shown in Fig. 3-45.

With the GPSV mode armed, once the aircraft arrives within 25% of the glidepath centerline, either above or below, the glidepath is captured. The active pitch mode annunciation will be replaced by CAP, to indicate engagement of the GPSV CAP mode, and a vertical speed will be established that is proportional to the indicated airspeed, as shown in Fig. 3-46.

With the GPSV CAP mode engaged, once the aircraft arrives within 5% of the glidepath centerline, either above or below, or a period of 10 seconds has elapsed, the GPSV mode engages. The CAP annunciation will extinguish and GPSV will move into its place, as shown in Fig. 3-47. This marks the end of the intercept sequence, and the beginning of tracking.

At the Decision Height (DH) or Missed Approach Point (MAP), disconnect the autopilot to execute either a manual landing or go-around, respectively.

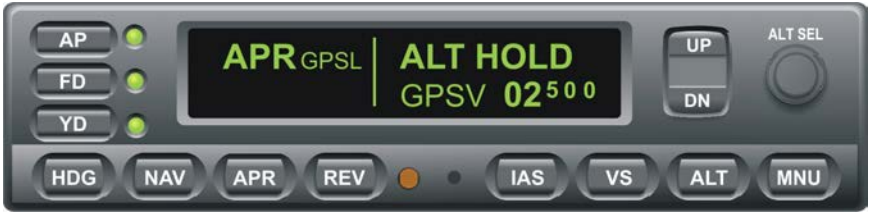

Fig. 3-45. AP Display, APR GPSL and ALT HOLD Modes Engaged, GPSV Mode Armed



Fig. 3-46. AP Display, APR GPSL and GPSV CAP Modes Engaged



Fig. 3-47. AP Display, APR GPSL and GPSV Modes Engaged

3.4 Yaw Damper (YD) Mode

With the AP READY annunciation displayed, pressing the AP mode selector switch will engage the yaw damper mode. This mode can be subsequently disengaged by pressing the YD mode selector switch, and then reengaged by pressing the switch again. Engagement is indicated by an illuminated YD LED, whereas disengagement is indicated by an extinguished YD LED. This is shown in Fig. 3-48 and 3-49, respectively. The yaw damper mode can be engaged or disengaged at any time, regardless of whichever roll axis or pitch axis mode happens to be engaged.

When the yaw damper mode is engaged, the yaw damper will dampen any excessive adverse yaw. The Yaw Trim Knob should be adjusted as required, to maintain a centered slip/skid ball.



Fig. 3-48. AP Display, YD Mode Engaged



Fig. 3-49. AP Display, YD Mode Disengaged

Caution:

1. ***Following any large power or flight profile change, disengage the yaw damper mode and check the basic aircraft rudder trim. Retrim if necessary using the Rudder Trim Wheel, and then reengage the yaw damper mode.***
2. ***The yaw damper mode should always be disengaged prior to takeoff and landing.***

3.5 Flight Director (FD) Operation

The flight director is a display of the flight profile. It is commanded by the autopilot. A pair of Command Bars and an Aircraft Symbol, superimposed upon a pitch ladder, comprise the flight director. The flight director operates either with both the AP and FD modes engaged, or with the AP mode disengaged and the FD mode engaged. Refer to S-TEC POH PN 87112-02 for more information on the flight director (i.e., PFD screen format).

3.5.1 AP and FD Modes Engaged

With the AP READY annunciation displayed, pressing the AP mode selector switch will engage the AP and FD modes. Engagement of these modes is indicated by an illuminated AP LED and FD LED, respectively, as shown in Fig. 3-50. The autopilot will steer the aircraft toward the Steering Command Bars, until the Aircraft Symbol is tucked into them, for any roll axis or pitch axis mode of operation. The flight director provides a visual indication of how accurately the autopilot is tracking its own roll and pitch commands.



Fig. 3-50. AP Display, AP and FD Modes Engaged

3.5.2 FD Mode Engaged and AP Mode Disengaged

With the AP READY annunciation displayed, pressing the FD mode selector switch will engage the FD mode, as indicated by an illuminated FD LED shown in Fig. 3-51. Alternately, with the AP READY annunciation displayed, pressing the AP mode selector switch will engage the AP and FD modes. Under this circumstance, press the AP mode selector switch again to disengage the AP mode, thereby disengaging both the roll and pitch servos. With the FD mode engaged and the AP mode disengaged, the pilot must steer the aircraft toward the Command Bars, until the Aircraft Symbol is tucked into them, for any roll axis or pitch axis mode of operation. The flight director provides a visual indication of how accurately the pilot is tracking the autopilot's roll and pitch commands.



Fig. 3-51. AP Display, FD Mode Engaged, AP Mode Disengaged

3.6 Go-Around (GA) Switch

Pressing the GA Switch will result in the following simultaneous events:

1. Disengagement of AP Mode
2. Engagement of FD Mode
3. Engagement of ROLL Mode, holding the roll attitude of wings level
4. Engagement of PITCH Mode, holding a pitch attitude specific to aircraft type
5. Cancellation of any armed roll mode
6. Cancellation of any armed pitch mode
7. Cancellation of any target altitude

3.7 Menu (MNU) Switch

Pressing the MNU mode selector switch enables the display contrast and brightness to be modified, and selected verbal alerts to be muted, as follows:

1. Rotate outer ALT SEL Concentric Knob CW to increase display contrast.
2. Rotate outer ALT SEL Concentric Knob CCW to decrease display contrast.
3. Rotate inner ALT SEL Concentric Knob CW to increase display brightness, and also that of mode selector switches.
4. Rotate inner ALT SEL Concentric Knob CCW to decrease display brightness, and also that of mode selector switches.
5. Press inner ALT SEL Concentric Knob to alternately select between MUTED ON and MUTED OFF, as indicated by the appearance of each particular icon shown in Fig. 3-52 and 3-53, respectively. When MUTED ON is selected, all verbal alerts are muted except for "Autopilot Disconnect". When MUTED OFF is selected, no verbal alerts are muted.



Fig. 3-52. MUTED ON Icon



Fig. 3-53. MUTED OFF Icon

S-TEC

6. Press UP Modifier Switch to increase brightness of AP, FD, and YD LEDs.
7. Press DN Modifier Switch to decrease brightness of AP, FD, and YD LEDs.

Menu activity does not affect the currently engaged autopilot modes of operation. If the autopilot does not detect any menu activity for a period of 5 seconds, it will revert to the previous display. All menu settings will be retained through subsequent power cycles, except for muted verbal alerts.

3.8 Automatic Trim Disable

The automatic trim function can be disabled by any of the following means:

1. Press/Hold Remote AP DISC / TRIM INTR Switch.
2. Set Trim Master Switch to OFF position.
3. Pull TRIM Circuit Breaker.

3.9 Autopilot Disconnect

The autopilot can be disconnected by any of the following means:

1. Press Remote AP DISC / TRIM INTR Switch.
2. Set AP Master Switch to OFF position.
3. Pull AP Circuit Breaker.
4. Press AP mode selector switch when AP mode is engaged, but FD mode is disengaged.
5. Press FD mode selector switch when FD mode is engaged, but AP mode is disengaged.

SECTION 4 OPERATING PARAMETERS

Page Intentionally Blank

4.1 Roll Axis Limits

Roll Attitude

38° (AP Disconnects)

Roll Rate

10°/sec (Roll Servo goes to Idle)

4.2 Pitch Axis Limits

Pitch Attitude

22° (AP Disconnects)

Pitch Rate

4°/sec (Pitch Servo goes to Idle)

Vertical Force Due to Acceleration

±0.6 g disregarding 1 g due to gravity (Pitch Servo goes to Idle)

1.6 g including 1 g due to gravity (Pitch Servo goes to Idle)

0.4 g including 1 g due to gravity (Pitch Servo goes to Idle)

4.3 Yaw Axis Limits

Lateral Force Due to Acceleration

0.05 g (Yaw Servo goes to Idle)

Page Intentionally Blank

SECTION 5 GLOSSARY

Page Intentionally Blank

Term	Meaning
A/C	Aircraft
ADAHRS	Air Data, Attitude, and Heading Reference System
AFM	Aircraft Flight Manual
AFMS	Aircraft Flight Manual Supplement
ALT	Altitude
AP	Autopilot
APR	Approach
CAP	Capture
CCW	Counter–Clockwise
CDI	Course Deviation Indication
CRS	Course
CW	Clockwise
CWS	Control Wheel Steering
DFCS	Digital Flight Control System
DH	Decision Height
DISC	Disconnect
FAA	Federal Aviation Administration
FAF	Final Approach Fix
FD	Flight Director
FPM	Feet–per–Minute
FT	Feet
GA	Go Around
GDI	Glideslope Deviation Indication
GPS	Global Positioning System
GPSL	Global Positioning System Lateral Navigation
GPSS	Global Positioning System Steering
GPSV	Global Positioning System Vertical Navigation
GS	Glideslope
HDG	Heading
IAF	Initial Approach Fix
IAS	Indicated Airspeed
IFR	Instrument Flight Rules
ILS	Instrument Landing System
INTR	Interrupt
KTS	Knots
LED	Light Emitting Diode
LOC	Localizer
MAP	Missed Approach Point
MNU	Menu
NAV	Navigation
PN	Part Number
POH	Pilot's Operating Handbook
RDY	Ready
REV	Reverse
SEL	Selector
VMC	Visual Meteorological Conditions
VOR	Very High Frequency Omnidirectional Radio Range
VS	Vertical Speed
YD	Yaw Damper

Page Intentionally Blank



Information contained in this document is subject to change without notice. © 2013 S-TEC. All rights reserved. Printed in the United States of America. S-TEC and the S-TEC logo are registered trademarks of S-TEC.

Notice:

Contact S-TEC Customer Support at 800-872-7832 for a Service Repair Order (SRO) number prior to the return of any component for any reason.

**One S-TEC Way
Municipal Airport
Mineral Wells, TX 76067-9236
Tel: 800-872-7832
Fax: 940-325-3904
www.genesys-aerosystems.com
S-TEC PN 87201**